

FIITJEE Solutions to IIT-JEE-2012

CODE
8

PAPER 2

Time: 3 Hours

Maximum Marks: 198

Please read the instructions carefully. You are allotted 5 minutes specifically for this purpose.

INSTRUCTIONS

A. General:

1. This booklet is your Question paper. Do not break the seats of this booklet before being instructed to do so by the invigilators.
2. The question paper CODE is printed on the right hand top corner of this page and on the back page of this booklet.
3. Blank spaces and blank pages are provided in this booklet for your rough work. No additional sheets will be provided for rough work.
4. Blank papers, clipboards, log tables, slide rules, calculators, cameras, cellular phones, pagers, and electronic gadgets are NOT allowed inside the examination hall.
5. Answers to the questions and personal details are to be filled on a two-part carbon-less paper, which is provided separately. You should not separate these parts. The invigilator will separate them at the end of examination. The upper sheet is machine-gradable Objective Response Sheet (ORS) which will be taken back by the invigilator. You will be allowed to take away the bottom sheet at the end of the examination.
6. **Using a black ball point pen, darken the bubbles on the upper original sheet.** Apply sufficient pressure so that the impression is created on the bottom sheet.
7. **DO NOT TAMPER WITH /MUTILATE THE ORS OR THE BOOKLET.**
8. On breaking the seals of the booklet check that it contains 36 pages and all 60 questions and corresponding answer choices are legible. Read carefully the instructions printed at the beginning of each section.

B. Filling the Right Part of the ORS:

9. The ORS has CODES printed on its left and right parts.
10. Check that the same CODE is printed on the ORS and on this booklet. **IF IT IS NOT THEN ASK FOR A CHANGE OF THE BOOKLET.** Sign at the place provided on the ORS affirming that you have verified that all the codes are same.
11. Write your Name, Registration Number and the name of examination centre and sign with pen in the boxes provided on the right part of the ORS. **Do not write any of this information anywhere else.** Darken the appropriate bubble **UNDER** each digit of your Registration Number in such a way that the impression is created on the bottom sheet. Also darken the paper CODE given on the right side of ORS(R₄).

C. Question Paper Format:

The question paper consists of 3 parts (Physics, Chemistry and Mathematics). Each part consists of three sections.

12. **Section I** contains **8 multiple choice questions**. Each question has four choices (A), (B), (C) and (D) out of which **ONLY ONE is correct**.
13. **Section II** contains **3 paragraphs** each describing theory, experiment, data etc. There are **6 multiple choice questions** relating to three paragraphs with **2 questions on each paragraph**. Each question of a particular paragraph has four choices (A), (B), (C) and (D) out of which **ONLY ONE is correct**.
14. **Section III** contains **6 multiple choice questions**. Each question has four choices (A), (B), (C) and (D) out of which **ONE or MORE** are correct.

D. Marking Scheme

15. For each question in **Section I and Section II**, you will be awarded **3 marks** if you darken the bubble corresponding to the correct answer **ONLY** and **zero (0) marks** if no bubbles are darkened. In all other cases, **minus one (-1) mark** will be awarded in these sections.
16. For each question in **Section III**, you will be awarded **4 marks** if you darken **ALL** the bubble(s) corresponding to the correct answer(s) **ONLY**. In all other cases **zero (0) marks** will be awarded. **No negative marks** will be awarded for incorrect answer(s) in this section.

Write your Name, Registration Number and sign in the space provided on the back page of this booklet.

PAPER-2 [Code – 8]

IITJEE 2012

PART - I: PHYSICS

SECTION I : Single Correct Answer Type

This section contains 8 multiple choice questions. Each question has four choices (A), (B), (C) and (D) out of which ONLY ONE is correct.

1. Two identical discs of same radius R are rotating about their axes in opposite directions with the same constant angular speed ω . The discs are in the same horizontal plane. At time $t = 0$, the points P and Q are facing each other as shown in the figure. The relative speed between the two points P and Q is v_r . In one time period (T) of rotation of the discs, v_r as a function of time is best represented by

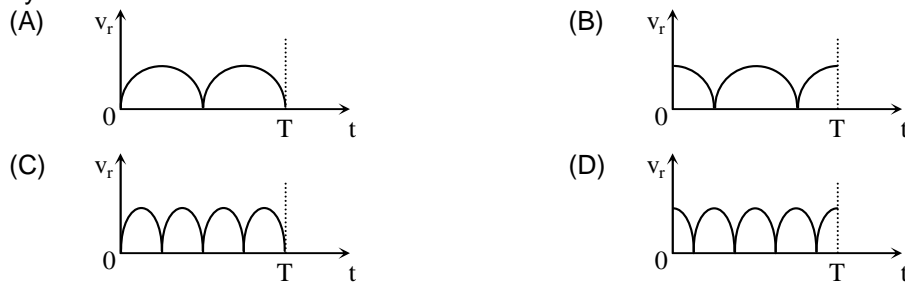
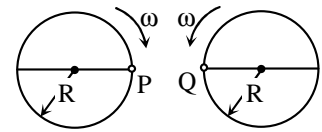

Sol. (A)

In each rotation relative speed becomes zero twice and becomes maximum twice.

2. A loop carrying current I lies in the x - y plane as shown in the figure. The unit vector \hat{k} is coming out of the plane of the paper. The magnetic moment of the current loop is

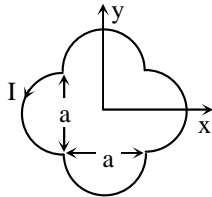

- (A) $a^2 I \hat{k}$ (B) $\left(\frac{\pi}{2} + 1\right) a^2 I \hat{k}$ (C) $-\left(\frac{\pi}{2} + 1\right) a^2 I \hat{k}$ (D) $(2\pi + 1) a^2 I \hat{k}$

Sol. (B)

$$\text{Magnetic moment, } \vec{M} = I\vec{A} = I\left(\frac{\pi}{2} + 1\right) a^2 \hat{K}$$

3. An infinitely long hollow conducting cylinder with inner radius $R/2$ and outer radius R carries a uniform current density along its length. The magnitude of the magnetic field, $|\vec{B}|$ as a function of the radial distance r from the axis is best represented by



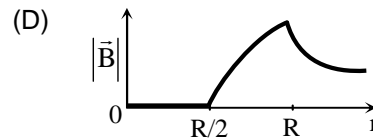
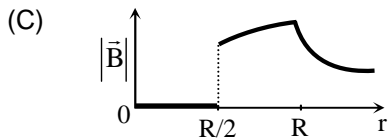

Sol.

(D)

Inside the cavity, $B = 0$

Outside the cylinder, $B = \frac{\mu_0 I}{2\pi r}$

In the shaded region

$$B = \frac{\mu_0 I}{2\pi r(b^2 - a^2)} \left(r - \frac{a^2}{r} \right)$$

at $r = a$, $B = 0$

at $r = b$, $B = \frac{\mu_0 I}{2\pi b}$

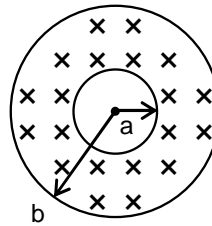

4. A thin uniform cylindrical shell, closed at both ends, is partially filled with water. It is floating vertically in water in half-submerged state. If ρ_c is the relative density of the material of the shell with respect to water, then the correct statement is that the shell is
- (A) more than half-filled if ρ_c is less than 0.5. (B) more than half-filled if ρ_c is more than 1.0.
 (C) half-filled if ρ_c is more than 0.5. (D) less than half-filled if ρ_c is less than 0.5.

Sol.

(A)

$$\frac{V_m + V_a + V_w}{2} \rho_w g = V_m \rho_c \rho_w g + V_w \rho_w g$$

$$V_w = V_m (1 - 2\rho_c) + V_a$$

$$\text{if } \rho_c > \frac{1}{2} \Rightarrow V_w < V_a$$

$$\text{if } \rho_c < \frac{1}{2} \Rightarrow V_w > V_a,$$

where, V_w = volume occupied by water in the shell

V_a = volume occupied by air in the shell

V_m = volume of the material in the shell

5. In the given circuit, a charge of $+80 \mu\text{C}$ is given to the upper plate of the $4 \mu\text{F}$ capacitor. Then in the steady state, the charge on the upper plate of the $3 \mu\text{F}$ capacitor is

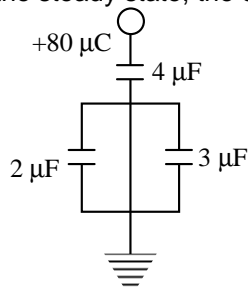

- (A) $+32 \mu\text{C}$ (B) $+40 \mu\text{C}$ (C) $+48 \mu\text{C}$ (D) $+80 \mu\text{C}$

Sol.

(C)

Let 'q' be the final charge on $3 \mu\text{F}$ capacitor then

$$\frac{80 - q}{2} = \frac{q}{3} \Rightarrow q = 48 \mu\text{C}$$

6. Two moles of ideal helium gas are in a rubber balloon at 30°C . The balloon is fully expandable and can be assumed to require no energy in its expansion. The temperature of the gas in the

balloon is slowly changed to 35°C . The amount of heat required in raising the temperature is nearly (take $R = 8.31 \text{ J/mol.K}$)

- (A) 62 J (B) 104 J (C) 124 J (D) 208 J

Sol. (D)
 $\Delta Q = nC_p \Delta T$ (Isobaric process)

$$= 2 \times \frac{5}{2} R \times (35 - 30)$$

$$= 208 \text{ J}$$

7. Consider a disc rotating in the horizontal plane with a constant angular speed ω about its centre O. The disc has a shaded region on one side of the diameter and an unshaded region on the other side as shown in the figure. When the disc is in the orientation as shown, two pebbles P and Q are simultaneously projected at an angle towards R. The velocity of projection is in the y-z plane and is same for both pebbles with respect to the disc. Assume that (i) they land back on the disc before the disc has completed $\frac{1}{8}$ rotation, (ii) their range is less than half the disc radius, and (iii) ω remains constant throughout. Then

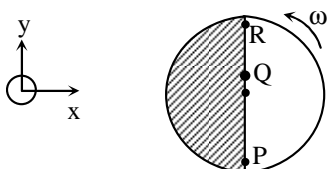

- (A) P lands in the shaded region and Q in the unshaded region.
 (B) P lands in the unshaded region and Q in the shaded region.
 (C) Both P and Q land in the unshaded region.
 (D) Both P and Q land in the shaded region.

Sol. (C)

$$\text{At } t = \frac{1}{8} \times \frac{2\pi}{\omega} = \frac{\pi}{4\omega}$$

$$x\text{-coordinate of P} = \omega R \left(\frac{\pi}{4\omega} \right)$$

$$= \frac{\pi R}{4} > R \cos 45^\circ$$

\therefore Both particles P and Q land in unshaded region.

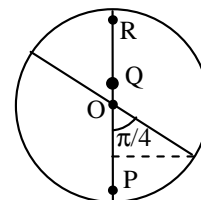

8. A student is performing the experiment of resonance Column. The diameter of the column tube is 4 cm. The frequency of the tuning fork is 512 Hz. The air temperature is 38°C in which the speed of sound is 336 m/s. The zero of the meter scale coincides with the top end of the Resonance Column tube. When the first resonance occurs, the reading of the water level in the column is
- (A) 14.0 cm (B) 15.2 cm (C) 16.4 cm (D) 17.6 cm

Sol. (B)

$$L + e = \frac{\lambda}{4}$$

$$\Rightarrow L = \frac{\lambda}{4} - e$$

$$= 16.4 - 1.2 = 15.2 \text{ cm}$$

SECTION II : Paragraph Type

This section contains **6 multiple choice questions** relating to three paragraphs with **two questions on each paragraph**. Each question has four choices (A), (B), (C) and (D) out of which **ONLY ONE is correct**.

Paragraph for Questions 9 and 10

The general motion of a rigid body can be considered to be a combination of (i) a motion of its centre of mass about an axis, and (ii) its motion about an instantaneous axis passing through the centre of mass. These axes need not be stationary. Consider, for example, a thin uniform disc welded (rigidly fixed) horizontally at its rim to a massless stick, as shown in the figure. When the disc-stick system is rotated about the origin on a horizontal frictionless plane with angular speed ω , the motion at any instant can be taken as a combination of (i) a rotation of the centre of mass of the disc about the z-axis, and (ii) a rotation of the disc through an instantaneous vertical axis passing through its centre of mass (as is seen from the changed orientation of points P and Q). Both these motions have the same angular speed ω in this case

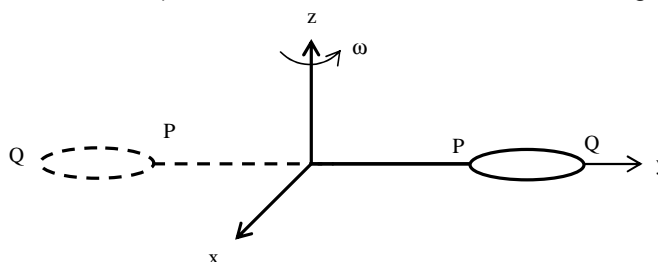

Now consider two similar systems as shown in the figure: Case(a) the disc with its face vertical and parallel to x-z plane; Case (b) the disc with its face making an angle of 45° with x-y plane and its horizontal diameter parallel to x-axis. In both the cases, the disc is welded at point P, and the systems are rotated with constant angular speed ω about the z-axis.

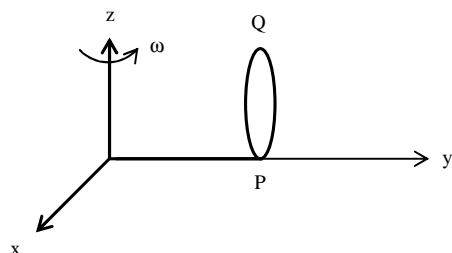

Case (a)

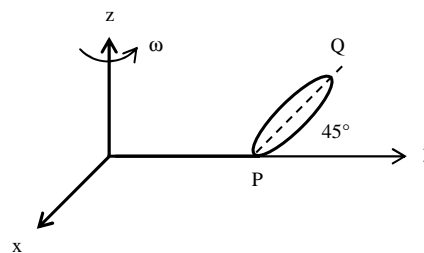

Case (b)

9. Which of the following statements about the instantaneous axis (passing through the centre of mass) is correct?
- (A) It is vertical for both the cases (a) and (b)
 (B) It is vertical for case (a); and is at 45° to the x-z plane and lies in the plane of the disc for case (b).
 (C) It is horizontal for case (a); and is at 45° to the x-z plane and is normal to the plane of the disc for case (b).
 (D) It is vertical for case (a); and is 45° to the x-z plane and is normal to the plane of the disc for case (b).

Sol. (A)

10. Which of the following statements regarding the angular speed about the instantaneous axis (passing through the centre of mass) is correct?

- (A) It is $\sqrt{2}\omega$ for both the cases. (B) It is ω for case (a); and $\frac{\omega}{\sqrt{2}}$ for case (b).
 (C) It is ω for case (a); and $\sqrt{2}\omega$ for case (b). (D) It is ω for both the cases.

Sol. (D)

Paragraph for Questions 11 and 12

The β -decay process, discovered around 1900, is basically the decay of a neutron (n). In the laboratory, a proton (p) and an electron (e^-) are observed as the decay products of the neutron. Therefore, considering the decay of a neutron as a two-body decay process, it was predicted theoretically that the kinetic energy of the electron should be a constant. But experimentally, it was observed that the electron kinetic energy has continuous spectrum. Considering a three-body decay process, i.e. $n \rightarrow p + e^- + \bar{\nu}_e$, around 1930, Pauli explained the observed electron energy spectrum. Assuming the anti-neutrino ($\bar{\nu}_e$) to be massless and possessing negligible energy, and the neutron to be at rest, momentum and energy conservation principles are applied. From this calculation, the maximum kinetic energy of the electron is 0.8×10^6 eV. The kinetic energy carried by the proton is only the recoil energy.

11. If the anti-neutrino had a mass of $3\text{eV}/c^2$ (where c is the speed of light) instead of zero mass, what should be the range of the kinetic energy, K , of the electron?

- (A) $0 \leq K \leq 0.8 \times 10^6$ eV (B) $3.0\text{eV} \leq K \leq 0.8 \times 10^6$ eV
 (C) $3.0\text{eV} \leq K < 0.8 \times 10^6$ eV (D) $0 \leq K < 0.8 \times 10^6$ eV

Sol. (D)

12. What is the maximum energy of the anti-neutrino?

- (A) Zero (B) Much less than 0.8×10^6 eV.
 (C) Nearly 0.8×10^6 eV (D) Much larger than 0.8×10^6 eV

Sol. (C)

Paragraph for Questions 13 and 14

Most materials have the refractive index, $n > 1$. So, when a light ray from air enters a naturally occurring material, then by Snell's law, $\frac{\sin \theta_1}{\sin \theta_2} = \frac{n_2}{n_1}$, it is understood that the refracted ray bends towards the normal.

But it never emerges on the same side of the normal as the incident ray. According to electromagnetism, the refractive index of the medium is given by the relation, $n = \left(\frac{c}{v}\right) = \pm \sqrt{\epsilon_r \mu_r}$, where c is the speed of electromagnetic waves in vacuum, v its speed in the medium, ϵ_r and μ_r are the relative permittivity and permeability of the medium respectively.

In normal materials, both ϵ_r and μ_r , are positive, implying positive n for the medium. When both ϵ_r and μ_r are negative, one must choose the negative root of n . Such negative refractive index materials can now be artificially prepared and are called meta-materials. They exhibit significantly different optical behavior, without violating any physical laws. Since n is negative, it results in a change in the direction of propagation of the refracted light. However, similar to normal materials, the frequency of light remains unchanged upon refraction even in meta-materials.

13. For light incident from air on a meta-material, the appropriate ray diagram is

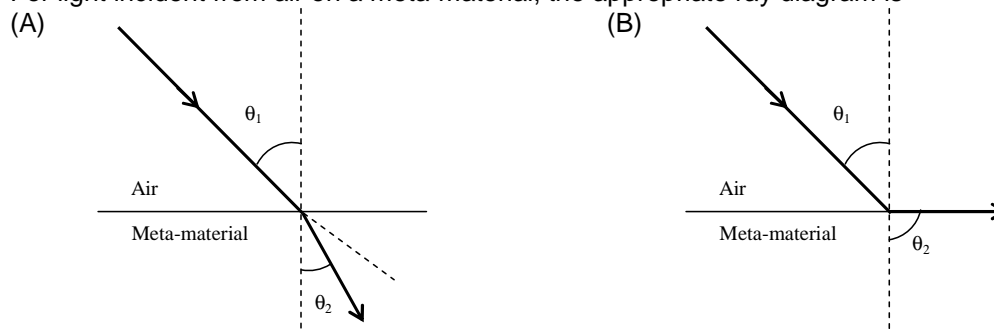

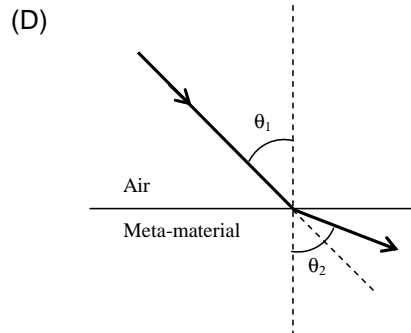
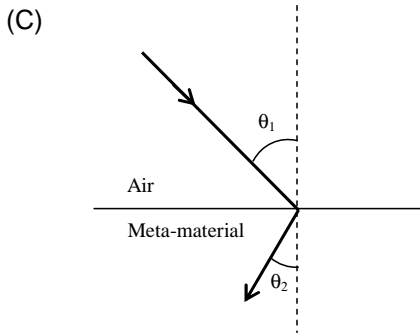

Sol. (C)

14. Choose the correct statement.

(A) The speed of light in the meta-material is $v = c|n|$

(B) The speed of light in the meta-material is $v = \frac{c}{|n|}$

(C) The speed of light in the meta-material is $v = c$.

(D) The wavelength of the light in the meta-material (λ_m) is given by $\lambda_m = \lambda_{air} |n|$, where λ_{air} is wavelength of the light in air.

Sol. (B)

SECTION III : Multiple Correct Answer(s) Type

This section contains **6 multiple choice questions**. Each question has four choices (A), (B), (C) and (D) out of which **ONE or MORE are correct**.

15. In the given circuit, the AC source has $\omega = 100 \text{ rad/s}$. Considering the inductor and capacitor to be ideal, the correct choice(s) is (are)

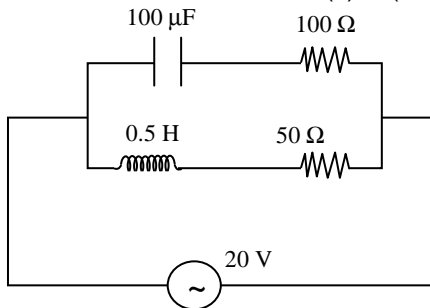

(A) The current through the circuit, I is 0.3 A.

(B) The current through the circuit, I is $0.3\sqrt{2}$ A.

(C) The voltage across 100Ω resistor = $10\sqrt{2}$ V. (D) The voltage across 50Ω resistor = 10 V.

Sol. (A, C)

$$I_{\text{upper}} = \frac{20}{100\sqrt{2}}; +\frac{\pi}{4} \text{ ahead of voltage}$$

$$I_{\text{lower}} = \frac{20}{50\sqrt{2}}; -\frac{\pi}{4} \text{ behind voltage}$$

$$I = \sqrt{I_1^2 + I_2^2} = \sqrt{\frac{1}{10}} \approx 0.3 \text{ A}$$

$$V_{100 \Omega} = \frac{20}{100\sqrt{2}} \times 100 = 10\sqrt{2}.$$

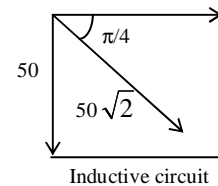
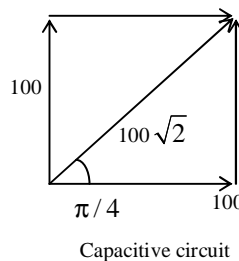

16. Six point charges are kept at the vertices of a regular hexagon of side L and centre O , as shown in the figure. Given that $K = \frac{1}{4\pi\epsilon_0} \frac{q}{L^2}$, which of the following statement(s) is (are) correct?

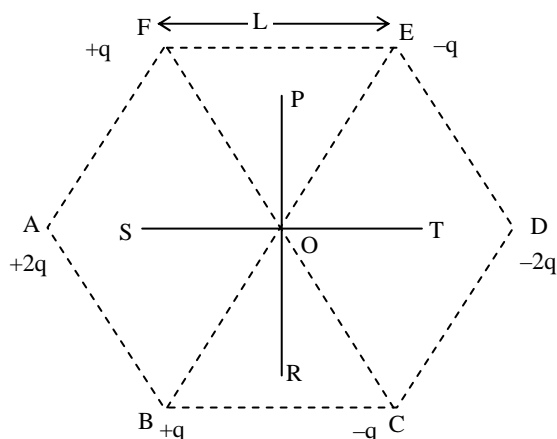

- (A) The electric field at O is $6K$ along OD .
 (B) The potential at O is zero.
 (C) The potential at all points on the line PR is same.
 (D) The potential at all points on the line ST is same.

Sol.

(A, B, C)

Line PR is perpendicular bisector of all the dipoles.

$$\text{At point } O: \frac{1}{4\pi\epsilon_0} \sum \frac{Q_i}{r_i} = 0$$

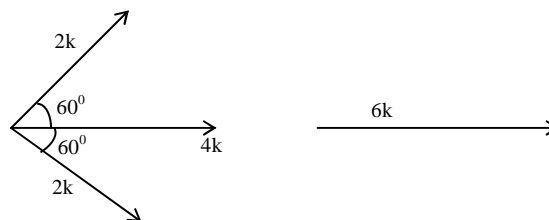

17. Two spherical planets P and Q have the same uniform density ρ , masses M_p and M_Q and surface areas A and $4A$ respectively. A spherical planet R also has uniform density ρ and its mass is $(M_p + M_Q)$. The escape velocities from the planets P , Q and R are V_p , V_Q and V_R , respectively. Then
- (A) $V_Q > V_R > V_p$
 (B) $V_R > V_Q > V_p$
 (C) $V_R / V_p = 3$
 (D) $V_p / V_Q = \frac{1}{2}$

Sol.

(B, D)

By calculation, if Mass of $P = m$
 and Radius of $P = R$
 Then Mass of $Q = 8M$
 and radius of $Q = 2R$
 and Mass of $R = 9M$
 and radius of $R = 9^{1/3}R$

$$V_p = \sqrt{\frac{2GM}{R}}$$

$$V_Q = \sqrt{\frac{2G8M}{2R}} = 2V_p$$

$$V_R = \sqrt{\frac{2G9M}{9^{1/3}R}} = 9^{1/3}V_p$$

$$\therefore V_R > V_Q > V_p$$

$$\frac{V_Q}{V_p} = 2$$

18. The figure shows a system consisting of (i) a ring of outer radius $3R$ rolling clockwise without slipping on a horizontal surface with angular speed ω and (ii) an inner disc of radius $2R$ rotating anti-clockwise with angular speed $\omega/2$. The ring and disc are separated by frictionless ball bearings. The point P on the inner disc is at a distance R from the origin, where OP makes an angle of 30° with the horizontal. Then with respect to the horizontal surface,

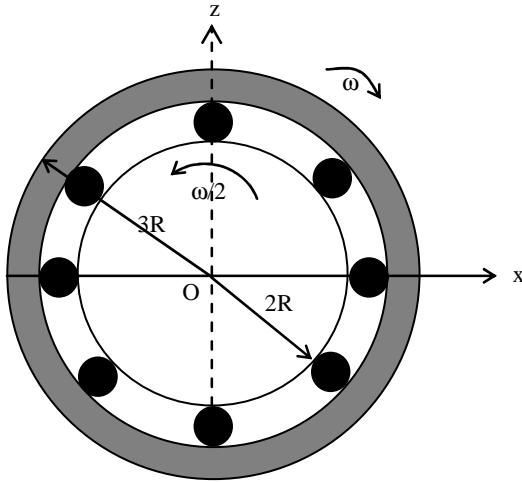

- (A) the point O has linear velocity $3R\omega\hat{i}$
- (B) the point P has linear velocity $\frac{11}{4}R\omega\hat{i} + \frac{\sqrt{3}}{4}R\omega\hat{k}$.
- (C) the point P has linear velocity $\frac{13}{4}R\omega\hat{i} - \frac{\sqrt{3}}{4}R\omega\hat{k}$
- (D) the point P has linear velocity $\left(3 - \frac{\sqrt{3}}{4}\right)R\omega\hat{i} + \frac{1}{4}R\omega\hat{k}$

Sol. (A, B)

$$\vec{V}_O = (3R)\omega\hat{i} = 0$$

$$\therefore \vec{v}_O = 3R\omega\hat{i}$$

$$\vec{v}_{P,O} = \frac{-R\omega\hat{i}}{4} + \frac{R\omega\sqrt{3}\hat{j}}{4}$$

$$\therefore \vec{v}_P = \vec{v}_{P,O} + \vec{v}_O$$

$$= \frac{11}{4}R\omega\hat{i} + R\omega\frac{\sqrt{3}}{4}\hat{j}$$

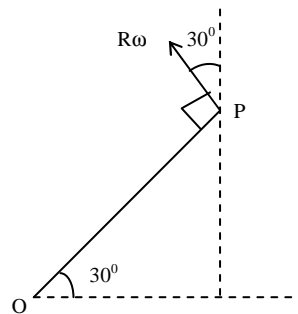

19. Two solid cylinders P and Q of same mass and same radius start rolling down a fixed inclined plane from the same height at the same time. Cylinder P has most of its mass concentrated near its surface, while Q has most of its mass concentrated near the axis. Which statement(s) is(are) correct?

- (A) Both cylinders P and Q reach the ground at the same time.
- (B) Cylinder P has larger linear acceleration than cylinder Q.
- (C) Both cylinders reach the ground with same translational kinetic energy.
- (D) Cylinder Q reaches the ground with larger angular speed.

Sol. (D)

$$a = \frac{Mg \sin \theta}{M + \frac{I}{R^2}}$$

$$a_P = \frac{Mg \sin \theta}{M + \frac{MR^2}{R^2}} \approx \frac{g}{2}$$

$$a_Q = g \sin \theta \quad \text{as } I_Q \sim 0$$

$$\therefore \omega_P = \frac{\sqrt{2 \cdot \frac{g}{2} \cdot \ell}}{R}$$

$$\omega_Q = \frac{\sqrt{2 \cdot g \cdot \ell}}{R}$$

$$\therefore \omega_Q > \omega_P$$

20. A current carrying infinitely long wire is kept along the diameter of a circular wire loop, without touching it, the correct statement(s) is(are)
- (A) The emf induced in the loop is zero if the current is constant.
 (B) The emf induced in the loop is finite if the current is constant.
 (C) The emf induced in the loop is zero if the current decreases at a steady rate.
 (D) The emf induced in the loop is infinite if the current decreases at a steady rate.

Sol.

(A, C)

$$\phi = \text{zero}$$

$$\therefore \frac{d\phi}{dt} = \text{zero}$$

\therefore A, C are correct.

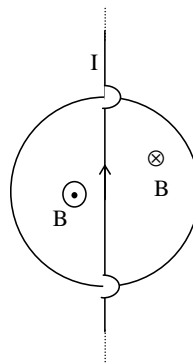

PAPER-2 [Code – 8]

IITJEE 2012

PART - II: CHEMISTRY

SECTION I : Single Correct Answer Type

This section contains **8 multiple choice questions**. Each question has four choices (A), (B), (C) and (D) out of which **ONLY ONE is correct**.

21. The major product **H** of the given reaction sequence is

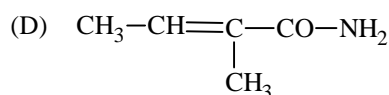
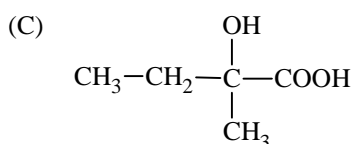
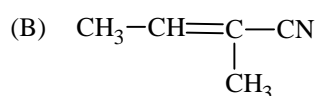
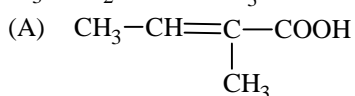
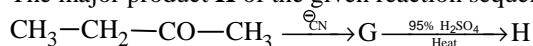

Sol.

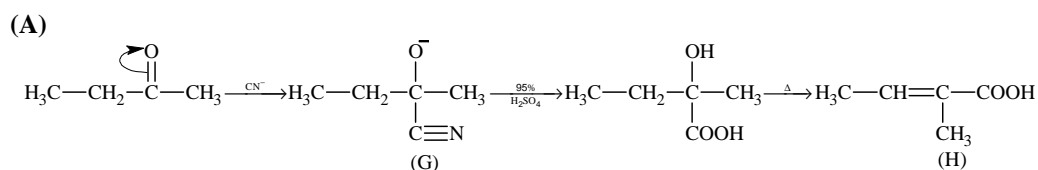

22. $\text{NiCl}_2\{\text{P}(\text{C}_2\text{H}_5)_2(\text{C}_6\text{H}_5)\}_2$ exhibits temperature dependent magnetic behaviour (paramagnetic/diamagnetic). The coordination geometries of Ni^{2+} in the paramagnetic and diamagnetic states are respectively

- (A) tetrahedral and tetrahedral (B) square planar and square planar
 (C) tetrahedral and square planar (D) square planar and tetrahedral

Sol.

(C)

In both complexes Ni exists as Ni^{2+} .

In sp^3 (tetrahedral)

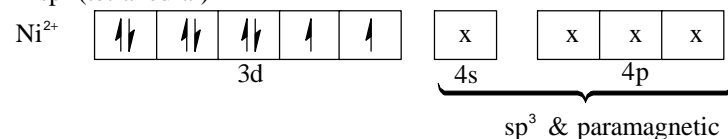

In dsp^2 (square planar geometry)

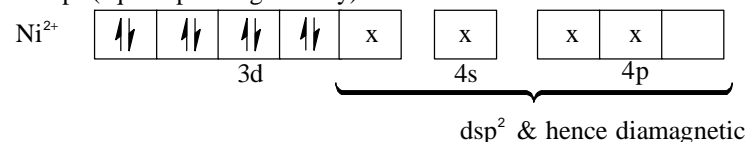

23. In the cyanide extraction process of silver from argentite ore, the oxidising and reducing agents used are

- (A) O_2 and CO respectively (B) O_2 and Zn dust respectively
 (C) HNO_3 and Zn dust respectively (D) HNO_3 and CO respectively

Sol.

(B)

The reactions involved in cyanide extraction process are:



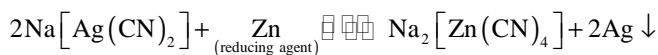

24. The reaction of white phosphorous with aqueous NaOH gives phosphine along with another phosphorous containing compound. The reaction type; the oxidation states of phosphorus in phosphine and the other product are respectively
- (A) redox reaction; -3 and -5
 (B) redox reaction; +3 and +5
 (C) disproportionation reaction; -3 and +5
 (D) disproportionation reaction; -3 and +3

Sol. (C)

The balanced disproportionation reaction involving white phosphorus with aq. NaOH is

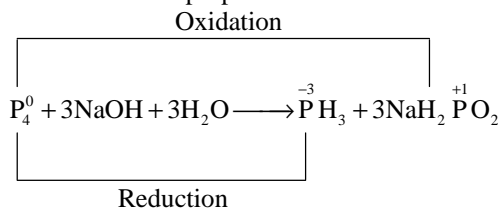

* However, as the option involving +1 oxidation state is completely missing, one might consider that NaH_2PO_2 formed has undergone thermal decomposition as shown below:

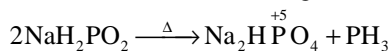

Although heating is nowhere mentioned in the question, the "other product" as per available options seems to be Na_2HPO_4 (oxidation state = +5).

- *25. The shape of XeO_2F_2 molecule is
- (A) trigonal bipyramidal
 (B) square planar
 (C) tetrahedral
 (D) see-saw

Sol. (D)

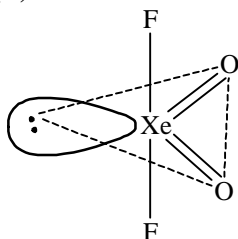

Hybridization = sp^3d
 Shape = see - saw

26. For a dilute solution containing 2.5 g of a non-volatile non-electrolyte solute in 100 g of water, the elevation in boiling point at 1 atm pressure is 2°C . Assuming concentration of solute is much lower than the concentration of solvent, the vapour pressure (mm of Hg) of the solution is (take $K_b = 0.76 \text{ K kg mol}^{-1}$)
- (A) 724
 (B) 740
 (C) 736
 (D) 718

Sol. (A)

$B \rightarrow$ Solute; $A \rightarrow$ Solvent

$W_B = 2.5 \text{ g}$, $W_A = 100 \text{ g}$

$\Delta T_b = 2^\circ$

$$\frac{p^\circ - p_s}{p^\circ} = X_B = \frac{n_B}{n_B + n_A}$$

$$\frac{p^\circ - p_s}{p^\circ} = \frac{n_B}{n_A} \quad \because n_B \ll n_A$$

$$\frac{p^\circ - p_s}{p^\circ} = \frac{n_B}{n_A}$$

$$\frac{760 - p_{\text{soln}}}{760} = \frac{2.5/M}{\frac{100}{18} \times \frac{1000}{1000}} = \frac{m \times 18}{1000} \quad \dots(i)$$

and from boiling point elevation,

$$2 = 0.76 \times m$$

$$m = \frac{2}{0.76} \quad \dots(ii)$$

on equating (i) and (ii)

$$p_{\text{soln}} = 724 \text{ mm}$$

27. The compound that undergoes decarboxylation most readily under mild condition is

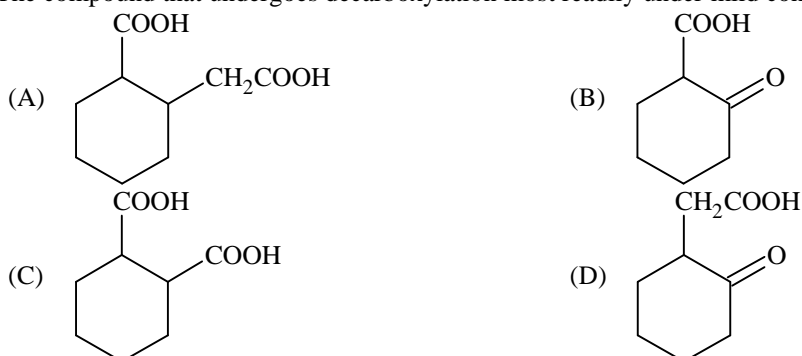

- Sol.** (B) β -keto acids undergoes decarboxylation easily.

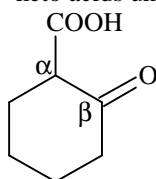

(β -keto acid)

- *28. Using the data provided, calculate the multiple bond energy (kJ mol^{-1}) of a $\text{C}\equiv\text{C}$ bond in C_2H_2 . That energy is (take the bond energy of a $\text{C}-\text{H}$ bond as 350 kJ mol^{-1})



- (A) 1165 (B) 837
(C) 865 (D) 815

- Sol.** (D)
- (i) $2\text{C}(s) + \text{H}_2(g) \longrightarrow \text{H}-\text{C}\equiv\text{C}-\text{H}(g) \quad \Delta H = 225 \text{ kJmol}^{-1}$
- (ii) $2\text{C}(s) \longrightarrow 2\text{C}(g) \quad \Delta H = 1410 \text{ kJmol}^{-1}$
- (iii) $\text{H}_2(g) \longrightarrow 2\text{H}(g) \quad \Delta H = 330 \text{ kJmol}^{-1}$

From equation (i):

$$225 = [2 \times \Delta H_{\text{C}(s) \rightarrow \text{C}(g)} + 1 \times \text{BE}_{\text{H}-\text{H}}] - [2 \times \text{BE}_{\text{C}-\text{H}} + 1 \times \text{BE}_{\text{C}\equiv\text{C}}]$$

$$225 = [1410 + 1 \times 330] - [2 \times 350 + 1 \times \text{BE}_{\text{C}\equiv\text{C}}]$$

$$225 = [1410 + 330] - [700 + \text{BE}_{\text{C}\equiv\text{C}}]$$

$$225 = 1740 - 700 - \text{BE}_{\text{C}\equiv\text{C}}$$

$$225 = 1040 - BE_{C\equiv C}$$

$$BE_{C\equiv C} = 1040 - 225 = 815 \text{ kJ mol}^{-1}$$

SECTION II : Paragraph Type

This section contains 6 **multiple choice questions** relating to three paragraphs with **two questions on each paragraph**. Each question has four choices (A), (B), (C) and (D) out of which **ONLY ONE is correct**.

Paragraph for Questions 29 and 30

In the following reaction sequence, the compound **J** is an intermediate.

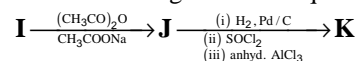

J ($\text{C}_9\text{H}_8\text{O}_2$) gives effervescence on treatment with NaHCO_3 and a positive Baeyer's test.

29. The compound **I** is

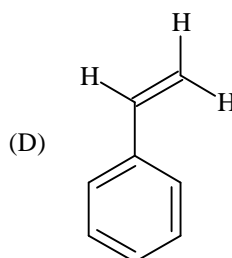
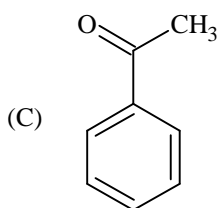
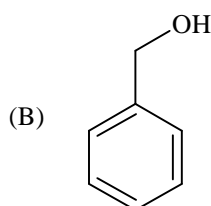
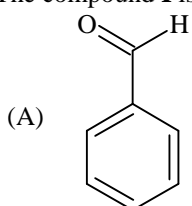

Ans.

(A)

30.

The compound **K** is

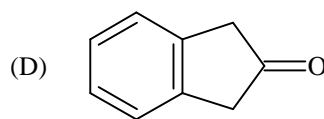
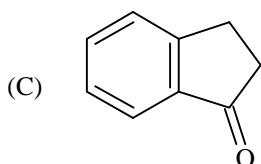
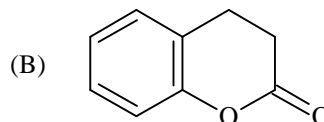
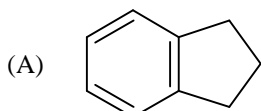

Ans.

(C)

Sol.

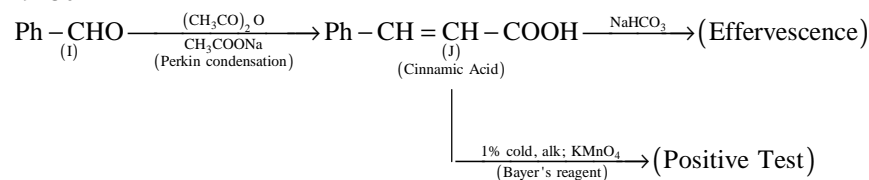

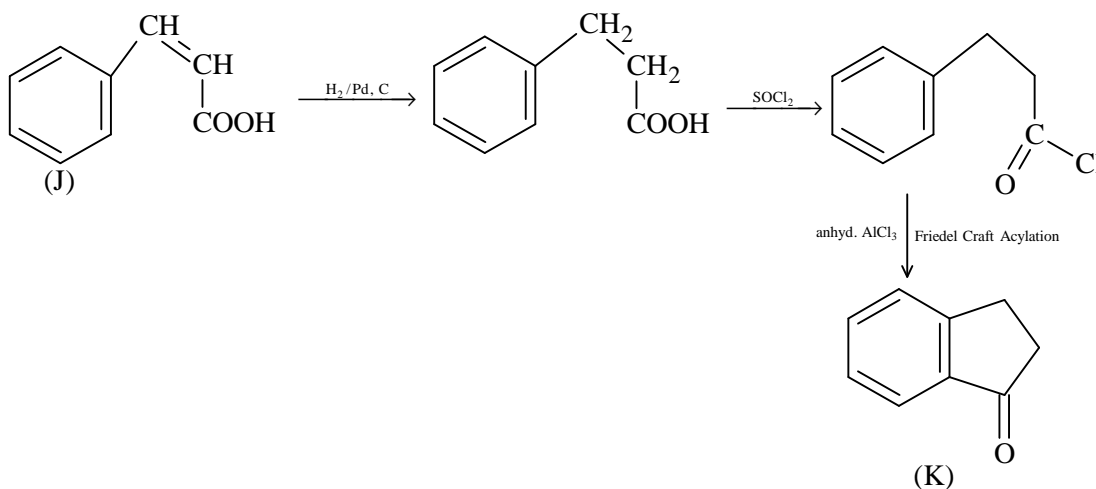

Paragraph for Questions 31 and 32

The electrochemical cell shown below is a concentration cell.

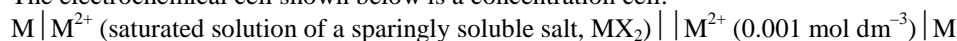

The emf of the cell depends on the difference in concentrations of M^{2+} ions at the two electrodes. The emf of the cell at 298 K is 0.059 V.

31. The value of ΔG (kJ mol^{-1}) for the given cell is (take $1F = 96500 \text{ C mol}^{-1}$)
- (A) -5.7 (B) 5.7
(C) 11.4 (D) -11.4

Sol. (D)

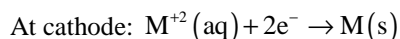
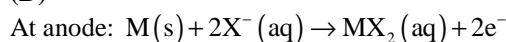

n -factor of the cell reaction is 2.

$$\Delta G = -nFE_{\text{cell}} = -2 \times 96500 \times 0.059 = -113873 / \text{mole} = -11.387 \text{ KJ / mole} \approx -11.4 \text{ KJ / mole}$$

32. The solubility product (K_{sp} ; $\text{mol}^3 \text{ dm}^{-9}$) of MX_2 at 298 K based on the information available for the given concentration cell is (take $2.303 \times R \times 298/F = 0.059 \text{ V}$)
- (A) 1×10^{-15} (B) 4×10^{-15}
(C) 1×10^{-12} (D) 4×10^{-12}

Sol. (B)

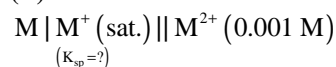

emf of concentration cell,

$$E_{\text{cell}} = \frac{-0.059}{n} \log \frac{[\text{M}^{+2}]_{\text{a}}}{[\text{M}^{+2}]_{\text{c}}}$$

$$0.059 = \frac{0.059}{2} \log \frac{[0.001]}{[\text{M}^{+2}]_{\text{a}}}$$

$$[\text{M}^{+2}]_{\text{a}} = 10^{-5} = S \text{ (solubility of salt in saturated solution)}$$

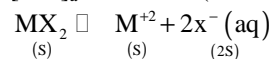

$$K_{\text{sp}} = 4S^3 = 4 \times (10^{-5})^3 = 4 \times 10^{-15}$$

Paragraph for Questions 33 and 34

Bleaching powder and bleach solution are produced on a large scale and used in several household products. The effectiveness of bleach solution is often measured by iodometry.

- *33. Bleaching powder contains a salt of an oxoacid as one of its components. The anhydride of that oxoacid is
 (A) Cl_2O (B) Cl_2O_7
 (C) ClO_2 (D) Cl_2O_6

Sol. (A)

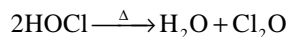
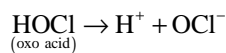
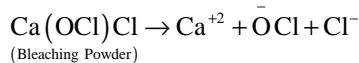

Anhydride of oxoacid (HOCl) is Cl_2O .

- *34. 25 mL of household solution was mixed with 30 mL of 0.50 M KI and 10 mL of 4 N acetic acid. In the titration of the liberated iodine, 48 mL of 0.25 N $\text{Na}_2\text{S}_2\text{O}_3$ was used to reach the end point. The molarity of the household bleach solution is
 (A) 0.48 M (B) 0.96 M
 (C) 0.24 M (D) 0.024 M

Sol. (C)

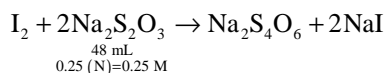
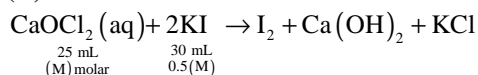

$$\text{So, number of millimoles of } \text{I}_2 \text{ produced} = 48 \times \frac{0.25}{2} = 24 \times 0.25 = 6$$

In reaction;

$$\text{Number of millimoles of bleaching powder } (n_{\text{CaOCl}_2}) = n_{\text{I}_2\text{-produced}} = \frac{1}{2} \times n_{\text{Na}_2\text{S}_2\text{O}_3 \text{ used}} = 6$$

$$\text{So, (M)} = \frac{n_{\text{CaOCl}_2}(\text{millimoles})}{V(\text{in mL})} = \frac{6 \text{ millimoles}}{25 \text{ mL}} = 0.24$$

SECTION III : Multiple Correct Answer(s) Type

The section contains **6 multiple choice questions**. Each question has four choices (A), (B), (C) and (D) out of which **ONE or MORE are correct**.

- *35. The reversible expansion of an ideal gas under adiabatic and isothermal conditions is shown in the figure. Which of the following statement(s) is (are) correct?

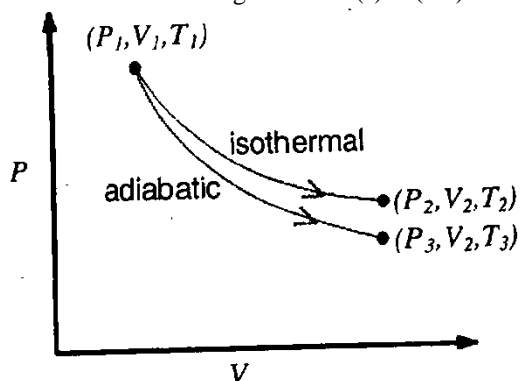

(A) $T_1 = T_2$

(C) $w_{\text{isothermal}} > w_{\text{adiabatic}}$

(B) $T_3 > T_1$

(D) $\Delta U_{\text{isothermal}} > \Delta U_{\text{adiabatic}}$

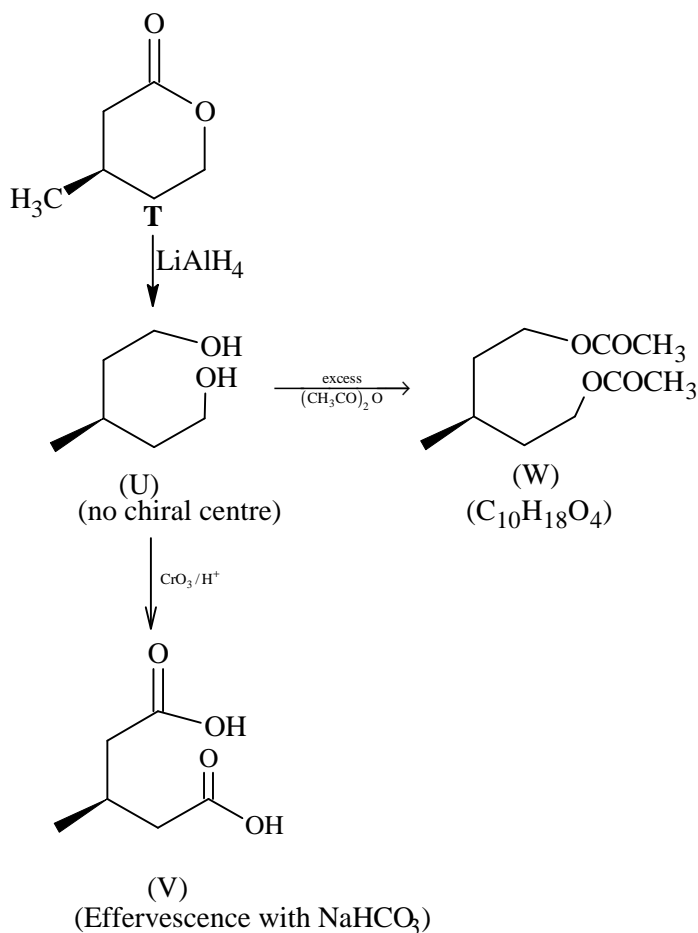

38. Which of the given statement(s) about **N**, **O**, **P** and **Q** with respect to **M** is (are) correct?

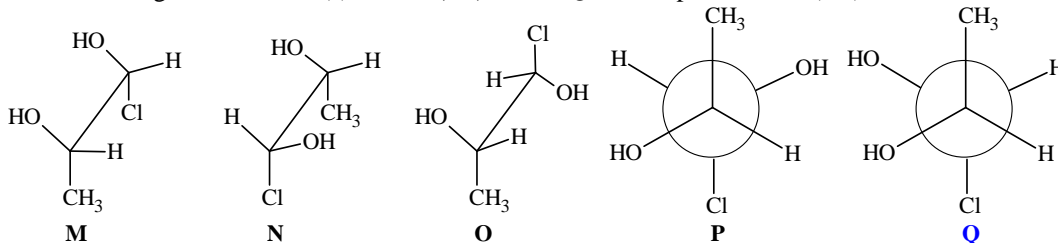

- (A) **M** and **N** are non-mirror image stereoisomers (B) **M** and **O** are identical
 (C) **M** and **P** are enantiomers (D) **M** and **Q** are identical

Sol. (A, B, C)

Converting all the structure in the Fischer projection

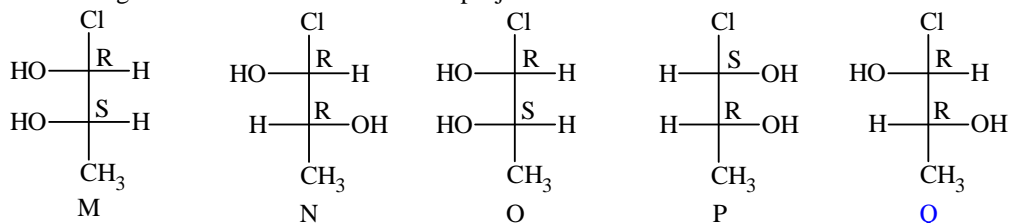

M and **N** are diastereoisomers

M and **O** are identical

M and **P** are enantiomers

M and **Q** are diastereoisomers

Hence, the correct options are A, B, C.

39. With respect to graphite and diamond, which of the statement(s) given below is (are) correct?

- (A) Graphite is harder than diamond.
 (B) Graphite has higher electrical conductivity than diamond.
 (C) Graphite has higher thermal conductivity than diamond.
 (D) Graphite has higher C–C bond order than diamond.

Sol. (B, D)

- ⇒ Diamond is harder than graphite.
 ⇒ Graphite is good conductor of electricity as each carbon is attached to three C-atoms leaving one valency free, which is responsible for electrical conduction, while in diamond, all the four valencies of carbon are satisfied, hence insulator.
 ⇒ Diamond is better thermal conductor than graphite. Whereas electrical conduction is due to availability of free electrons; thermal conduction is due to transfer of thermal vibrations from atom to atom. A compact and precisely aligned crystal like diamond thus facilitates fast movement of heat.
 ⇒ In graphite, C – C bond acquires double bond character, hence higher bond order than in diamond.

40. The given graphs / data I, II, III and IV represent general trends observed for different physisorption and chemisorption processes under mild conditions of temperature and pressure. Which of the following choice(s) about I, II, III and IV is (are) correct?

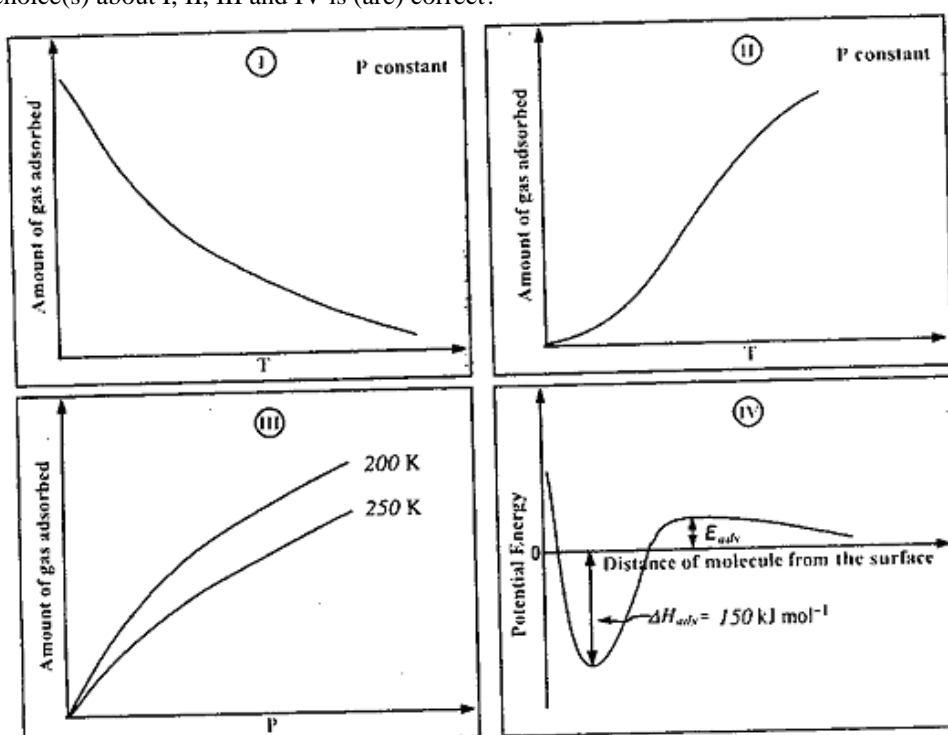

- (A) I is physisorption and II is chemisorption
 (B) I is physisorption and III is chemisorption
 (C) IV is chemisorption and II is chemisorption
 (D) IV is chemisorption and III is chemisorption

Sol. (A, C)

Graph (I) and (III) represent physisorption because, in physisorption, the amount of adsorption decreases with the increase of temperature and increases with the increase of pressure.

Graph (II) represent chemisorption, because in chemisorption amount of adsorption increase with the increase of temperature. Graph (IV) is showing the formation of a chemical bond, hence chemisorption.

PAPER-2 [Code – 8]

IITJEE 2012

PART - III: MATHEMATICS

SECTION I : Single Correct Answer Type

This section contains **8 multiple choice questions**. Each question has four choices (A), (B), (C) and (D) out of which **ONLY ONE is correct**.

41. Let a_1, a_2, a_3, \dots be in harmonic progression with $a_1 = 5$ and $a_{20} = 25$. The least positive integer n for which $a_n < 0$
- (A) 22 (B) 23
(C) 24 (D) 25

Sol. (D)

a_1, a_2, a_3, \dots are in H.P.

$\Rightarrow \frac{1}{a_1}, \frac{1}{a_2}, \frac{1}{a_3}, \dots$ are in A.P.

$$\Rightarrow \frac{1}{a_n} = \frac{1}{a_1} + (n-1)d < 0, \text{ where } \frac{\frac{1}{25} - \frac{1}{5}}{19} = d = \left(\frac{-4}{9 \times 25} \right)$$

$$\Rightarrow \frac{1}{5} + (n-1) \left(\frac{-4}{19 \times 25} \right) < 0$$

$$\frac{4(n-1)}{19 \times 5} > 1$$

$$n-1 > \frac{19 \times 5}{4}$$

$$n > \frac{19 \times 5}{4} + 1 \Rightarrow n \geq 25.$$

42. The equation of a plane passing through the line of intersection of the planes $x + 2y + 3z = 2$ and $x - y + z = 3$ and at a distance $\frac{2}{\sqrt{3}}$ from the point $(3, 1, -1)$ is
- (A) $5x - 11y + z = 17$ (B) $\sqrt{2}x + y = 3\sqrt{2} - 1$
(C) $x + y + z = \sqrt{3}$ (D) $x - \sqrt{2}y = 1 - \sqrt{2}$

Sol. (A)

Equation of required plane is

$$P \equiv (x + 2y + 3z - 2) + \lambda(x - y + z - 3) = 0$$

$$\Rightarrow (1 + \lambda)x + (2 - \lambda)y + (3 + \lambda)z - (2 + 3\lambda) = 0$$

Its distance from $(3, 1, -1)$ is $\frac{2}{\sqrt{3}}$

$$\Rightarrow \frac{2}{\sqrt{3}} = \frac{|3(1 + \lambda) + (2 - \lambda) - (3 + \lambda) - (2 + 3\lambda)|}{\sqrt{(\lambda + 1)^2 + (2 - \lambda)^2 + (3 + \lambda)^2}}$$

$$= \frac{4}{3} = \frac{(-2\lambda)^2}{3\lambda^2 + 4\lambda + 14} \Rightarrow 3\lambda^2 + 4\lambda + 14 = 3\lambda^2$$

$$\Rightarrow \lambda = -\frac{7}{2} \Rightarrow -\frac{5}{2}x + \frac{11}{2}y - \frac{z}{2} + \frac{17}{2} = 0$$

$$-5x + 11y - z + 17 = 0.$$

43. Let PQR be a triangle of area Δ with $a = 2$, $b = \frac{7}{2}$ and $c = \frac{5}{2}$, where a , b , and c are the lengths of the sides of the triangle opposite to the angles at P, Q and R respectively. Then $\frac{2 \sin P - \sin 2P}{2 \sin P + \sin 2P}$ equals

- (A) $\frac{3}{4\Delta}$ (B) $\frac{45}{4\Delta}$
 (C) $\left(\frac{3}{4\Delta}\right)^2$ (D) $\left(\frac{45}{4\Delta}\right)^2$

Sol. (C)

$$\begin{aligned} \frac{2 \sin P - 2 \sin P \cos P}{2 \sin P + 2 \sin P \cos P} &= \frac{1 - \cos P}{1 + \cos P} = \frac{2 \sin^2 \frac{P}{2}}{2 \cos^2 \frac{P}{2}} = \tan^2 \frac{P}{2} \\ &= \frac{(s-b)(s-c)}{s(s-a)} \\ &= \frac{((s-b)(s-c))^2}{\Delta^2} = \frac{\left(\left(\frac{1}{2}\right)\left(\frac{3}{2}\right)\right)^2}{\Delta^2} = \left(\frac{3}{4\Delta}\right)^2 \end{aligned}$$

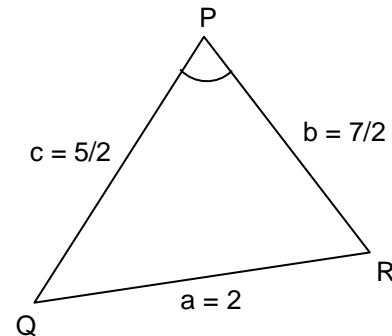

44. If \vec{a} and \vec{b} are vectors such that $|\vec{a} + \vec{b}| = \sqrt{29}$ and $\vec{a} \times (2\hat{i} + 3\hat{j} + 4\hat{k}) = (2\hat{i} + 3\hat{j} + 4\hat{k}) \times \vec{b}$, then a possible value of $(\vec{a} + \vec{b}) \cdot (-7\hat{i} + 2\hat{j} + 3\hat{k})$ is
- (A) 0 (B) 3
 (C) 4 (D) 8

Sol. (C)

$$\begin{aligned} \vec{a} \times (2\hat{i} + 3\hat{j} + 4\hat{k}) &= (2\hat{i} + 3\hat{j} + 4\hat{k}) \times \vec{b} \\ (\vec{a} + \vec{b}) \times (2\hat{i} + 3\hat{j} + 4\hat{k}) &= \vec{0} \\ \Rightarrow \vec{a} + \vec{b} &= \pm (2\hat{i} + 3\hat{j} + 4\hat{k}) \quad (\text{as } |\vec{a} + \vec{b}| = \sqrt{29}) \\ \Rightarrow (\vec{a} + \vec{b}) \cdot (-7\hat{i} + 2\hat{j} + 3\hat{k}) & \\ &= \pm (-14 + 6 + 12) = \pm 4. \end{aligned}$$

45. If P is a 3×3 matrix such that $P^T = 2P + I$, where P^T is the transpose of P and I is the 3×3 identity matrix,

then there exists a column matrix $X = \begin{bmatrix} x \\ y \\ z \end{bmatrix} \neq \begin{bmatrix} 0 \\ 0 \\ 0 \end{bmatrix}$ such that

- (A) $PX = \begin{bmatrix} 0 \\ 0 \\ 0 \end{bmatrix}$ (B) $PX = X$
 (C) $PX = 2X$ (D) $PX = -X$

Sol. (D)

$$\begin{aligned} \text{Give } P^T &= 2P + I \\ \Rightarrow P &= 2P^T + I = 2(2P + I) + I \\ \Rightarrow P + I &= 0 \\ \Rightarrow PX + X &= 0 \\ PX &= -X. \end{aligned}$$

46. Let $\alpha(a)$ and $\beta(a)$ be the roots of the equation $(\sqrt[3]{1+a}-1)x^2 + (\sqrt{1+a}-1)x + (\sqrt[6]{1+a}-1) = 0$ where $a > -1$. Then $\lim_{a \rightarrow 0^+} \alpha(a)$ and $\lim_{a \rightarrow 0^+} \beta(a)$ are

- (A) $-\frac{5}{2}$ and 1
 (B) $-\frac{1}{2}$ and -1
 (C) $-\frac{7}{2}$ and 2
 (D) $-\frac{9}{2}$ and 3

Sol. (B)

$$\begin{aligned} \text{Let } 1+a &= y \\ \Rightarrow (y^{1/3}-1)x^2 + (y^{1/2}-1)x + y^{1/6}-1 &= 0 \\ \Rightarrow \left(\frac{y^{1/3}-1}{y-1}\right)x^2 + \left(\frac{y^{1/2}-1}{y-1}\right)x + \frac{y^{1/6}-1}{y-1} &= 0 \end{aligned}$$

Now taking $\lim_{y \rightarrow 1}$ on both the sides

$$\begin{aligned} \Rightarrow \frac{1}{3}x^2 + \frac{1}{2}x + \frac{1}{6} &= 0 \\ \Rightarrow 2x^2 + 3x + 1 &= 0 \\ x &= -1, -\frac{1}{2}. \end{aligned}$$

47. Four fair dice D_1, D_2, D_3 and D_4 , each having six faces numbered 1, 2, 3, 4, 5, and 6, are rolled simultaneously. The probability that D_4 shows a number appearing on one of D_1, D_2 and D_3 is

- (A) $\frac{91}{216}$
 (B) $\frac{108}{216}$
 (C) $\frac{125}{216}$
 (D) $\frac{127}{216}$

Sol. (A)

$$\text{Required probability} = 1 - \frac{6 \cdot 5^3}{6^4} = 1 - \frac{125}{216} = \frac{91}{216}.$$

48. The value of the integral $\int_{-\pi/2}^{\pi/2} \left(x^2 + \ln \frac{\pi+x}{\pi-x} \right) \cos x \, dx$ is

- (A) 0
 (B) $\frac{\pi^2}{2} - 4$
 (C) $\frac{\pi^2}{2} + 4$
 (D) $\frac{\pi^2}{2}$

Sol. (B)

$$\begin{aligned} &\int_{-\pi/2}^{\pi/2} \left\{ x^2 + \ln \left(\frac{\pi+x}{\pi-x} \right) \right\} \cos x \, dx \\ &= \int_{-\pi/2}^{\pi/2} x^2 \cos x \, dx + \int_{-\pi/2}^{\pi/2} \ln \left(\frac{\pi+x}{\pi-x} \right) \cos x \, dx \\ &= 2 \int_0^{\pi/2} x^2 \cos x \, dx \\ &= 2 \left[x^2 \sin x + 2x \cos x - 2 \sin x \right]_0^{\pi/2} \end{aligned}$$

$$= 2 \left[\frac{\pi^2}{4} - 2 \right] = \frac{\pi^2}{2} - 4.$$

SECTION II : Paragraph Type

This section contains **6 multiple choice questions** relating to three paragraphs with **two questions on each paragraph**. Each question has four choices (A), (B), (C) and (D) out of which **ONLY ONE** is correct.

Paragraph for Questions 49 and 50

A tangent PT is drawn to the circle $x^2 + y^2 = 4$ at the point $P(\sqrt{3}, 1)$. A straight line L , perpendicular to PT is a tangent to the circle $(x-3)^2 + y^2 = 1$.

49. A possible equation of L is
- (A) $x - \sqrt{3}y = 1$ (B) $x + \sqrt{3}y = 1$
 (C) $x - \sqrt{3}y = -1$ (D) $x + \sqrt{3}y = 5$

Sol. (A)
 Equation of tangent at $P(\sqrt{3}, 1)$
 $\sqrt{3}x + y = 4$

Slope of line perpendicular to above tangent is $\frac{1}{\sqrt{3}}$

So equation of tangents with slope $\frac{1}{\sqrt{3}}$ to $(x-3)^2 + y^2 = 1$ will be

$$y = \frac{1}{\sqrt{3}}(x-3) \pm 1\sqrt{1 + \frac{1}{3}}$$

$$\sqrt{3}y = x - 3 \pm 2$$

$$\sqrt{3}y = x - 1 \text{ or } \sqrt{3}y = x - 5.$$

50. A common tangent of the two circles is
- (A) $x = 4$ (B) $y = 2$
 (C) $x + \sqrt{3}y = 4$ (D) $x + 2\sqrt{2}y = 6$

Sol. (D)
 Point of intersection of direct common tangents is $(6, 0)$

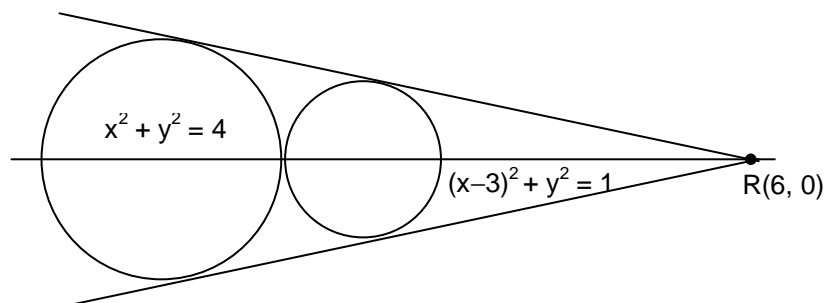

so let the equation of common tangent be

$$y - 0 = m(x - 6)$$

as it touches $x^2 + y^2 = 4$

$$\Rightarrow \left| \frac{0 - 0 + 6m}{\sqrt{1 + m^2}} \right| = 2$$

$$9m^2 = 1 + m^2$$

$$m = \pm \frac{1}{2\sqrt{2}}$$

So equation of common tangent

$$y = \frac{1}{2\sqrt{2}}(x-6), \quad y = -\frac{1}{2\sqrt{2}}(x-6) \quad \text{and also } x = 2$$

Paragraph for Questions 51 and 52

Let $f(x) = (1-x)^2 \sin^2 x + x^2$ for all $x \in \mathbb{R}$, and let $g(x) = \int_1^x \left(\frac{2(t-1)}{t+1} - \ln t \right) f(t) dt$ for all $x \in (1, \infty)$.

51. Consider the statements:

P : There exists some $x \in \mathbb{R}$ such that $f(x) + 2x = 2(1 + x^2)$

Q : There exists some $x \in \mathbb{R}$ such that $2f(x) + 1 = 2x(1 + x)$

Then

(A) both **P** and **Q** are true

(B) **P** is true and **Q** is false

(C) **P** is false and **Q** is true

(D) both **P** and **Q** are false

Sol. (C)

$$f(x) = (1-x)^2 \sin^2 x + x^2 \quad \forall x \in \mathbb{R}$$

$$g(x) = \int_1^x \left(\frac{2(t-1)}{t+1} - \ln t \right) f(t) dt \quad \forall x \in (1, \infty)$$

For statement **P** :

$$f(x) + 2x = 2(1 + x^2) \quad \dots(i)$$

$$(1-x)^2 \sin^2 x + x^2 + 2x = 2 + 2x^2$$

$$(1-x)^2 \sin^2 x = x^2 - 2x + 2 = (x-1)^2 + 1$$

$$(1-x)^2 (\sin^2 x - 1) = 1$$

$$-(1-x)^2 \cos^2 x = 1$$

$$(1-x)^2 \cdot \cos^2 x = -1$$

So equation (i) will not have real solution

So, **P** is wrong.

For statement **Q** :

$$2(1-x)^2 \sin^2 x + 2x^2 + 1 = 2x + 2x^2 \quad \dots(ii)$$

$$2(1-x)^2 \sin^2 x = 2x - 1$$

$$2\sin^2 x = \frac{2x-1}{(1-x)^2} \quad \text{Let } h(x) = \frac{2x-1}{(1-x)^2} - 2\sin^2 x$$

Clearly $h(0) = -ve$, $\lim_{x \rightarrow 1^-} h(x) = +\infty$

So by IVT, equation (ii) will have solution.

So, **Q** is correct.

52. Which of the following is true?

(A) g is increasing on $(1, \infty)$

(B) g is decreasing on $(1, \infty)$

(C) g is increasing on $(1, 2)$ and decreasing on $(2, \infty)$

(D) g is decreasing on $(1, 2)$ and increasing on $(2, \infty)$

Sol. (B)

$$g'(x) = \left(\frac{2(x-1)}{x+1} - \ln x \right) f(x). \quad \text{For } x \in (1, \infty), f(x) > 0$$

$$\text{Let } h(x) = \left(\frac{2(x-1)}{x+1} - \ln x \right) \Rightarrow h'(x) = \left(\frac{4}{(x+1)^2} - \frac{1}{x} \right) = \frac{-(x-1)^2}{(x+1)^2 x} < 0$$

Also $h(1) = 0$ so, $h(x) < 0 \quad \forall x > 1$

$\Rightarrow g(x)$ is decreasing on $(1, \infty)$.

Paragraph for Questions 53 and 54

Let a_n denote the number of all n -digit positive integers formed by the digits 0, 1 or both such that no consecutive digits in them are 0. Let b_n = the number of such n -digit integers ending with digit 1 and c_n = the number of such n -digit integers ending with digit 0.

53. The value of b_6 is
 (A) 7 (B) 8
 (C) 9 (D) 11

Sol. (B)
 $a_n = b_n + c_n$
 $b_n = a_{n-1}$
 $c_n = a_{n-2} \Rightarrow a_n = a_{n-1} + a_{n-2}$
 As $a_1 = 1, a_2 = 2, a_3 = 3, a_4 = 5, a_5 = 8 \Rightarrow b_6 = 8$.

54. Which of the following is correct?
 (A) $a_{17} = a_{16} + a_{15}$ (B) $c_{17} \neq c_{16} + c_{15}$
 (C) $b_{17} \neq b_{16} + c_{16}$ (D) $a_{17} = c_{17} + b_{16}$

Sol. (A)
 As $a_n = a_{n-1} + a_{n-2}$
 for $n = 17$
 $\Rightarrow a_{17} = a_{16} + a_{15}$.

SECTION III : Multiple Correct Answer(s) Type

This section contains **6 multiple choice questions**. Each question has four choices (A), (B), (C) and (D) out of which **ONE or MORE are correct**.

55. For every integer n , let a_n and b_n be real numbers. Let function $f: \mathbb{R} \rightarrow \mathbb{R}$ be given by

$$f(x) = \begin{cases} a_n + \sin \pi x, & \text{for } x \in [2n, 2n+1] \\ b_n + \cos \pi x, & \text{for } x \in (2n-1, 2n) \end{cases}$$
, for all integers n . If f is continuous, then which of the following hold(s) for all n ?
 (A) $a_{n-1} - b_{n-1} = 0$ (B) $a_n - b_n = 1$
 (C) $a_n - b_{n+1} = 1$ (D) $a_{n-1} - b_n = -1$

Sol. (B, D)
 At $x = 2n$
 L.H.L. = $\lim_{h \rightarrow 0} (b_n + \cos \pi(2n-h)) = b_n + 1$
 R.H.L. = $\lim_{h \rightarrow 0} (a_n + \sin \pi(2n+h)) = a_n$
 $f(2n) = a_n$
 For continuity $b_n + 1 = a_n$
 At $x = 2n + 1$
 L.H.L. = $\lim_{h \rightarrow 0} (a_n + \sin \pi(2n+1-h)) = a_n$
 R.H.L. = $\lim_{h \rightarrow 0} (b_{n+1} + \cos(\pi(2n+1-h))) = b_{n+1} - 1$
 $f(2n+1) = a_n$
 For continuity
 $a_n = b_{n+1} - 1$
 $a_{n-1} - b_n = -1$.

56. If the straight lines $\frac{x-1}{2} = \frac{y+1}{k} = \frac{z}{2}$ and $\frac{x+1}{5} = \frac{y+1}{2} = \frac{z}{k}$ are coplanar, then the plane(s) containing these two lines is(are)
- (A) $y + 2z = -1$ (B) $y + z = -1$
 (C) $y - z = -1$ (D) $y - 2z = -1$

Sol. (B, C)

For given lines to be coplanar, we get

$$\begin{vmatrix} 2 & k & 2 \\ 5 & 2 & k \\ 2 & 0 & 0 \end{vmatrix} = 0 \Rightarrow k^2 = 4, k = \pm 2$$

For $k = 2$, obviously the plane $y + 1 = z$ is common in both lines

For $k = -2$, family of plane containing first line is $x + y + \lambda(x - z - 1) = 0$.

Point $(-1, -1, 0)$ must satisfy it

$$-2 + \lambda(-2) = 0 \Rightarrow \lambda = -1$$

$$\Rightarrow y + z + 1 = 0.$$

57. If the adjoint of a 3×3 matrix P is $\begin{bmatrix} 1 & 4 & 4 \\ 2 & 1 & 7 \\ 1 & 1 & 3 \end{bmatrix}$, then the possible value(s) of the determinant of P is (are)
- (A) -2 (B) -1
 (C) 1 (D) 2

Sol. (A, D)

$$|\text{Adj } P| = |P|^2 \text{ as } (|\text{Adj } (P)| = |P|^{n-1})$$

$$\text{Since } |\text{Adj } P| = 1(3-7) - 4(6-7) + 4(2-1) = 4$$

$$|P| = 2 \text{ or } -2.$$

58. Let $f : (-1, 1) \rightarrow \mathbb{R}$ be such that $f(\cos 4\theta) = \frac{2}{2 - \sec^2 \theta}$ for $\theta \in \left(0, \frac{\pi}{4}\right) \cup \left(\frac{\pi}{4}, \frac{\pi}{2}\right)$. Then the value(s) of $f\left(\frac{1}{3}\right)$ is (are)
- (A) $1 - \sqrt{\frac{3}{2}}$ (B) $1 + \sqrt{\frac{3}{2}}$
 (C) $1 - \sqrt{\frac{2}{3}}$ (D) $1 + \sqrt{\frac{2}{3}}$

Sol. (A, B)

$$\text{For } \theta \in \left(0, \frac{\pi}{4}\right) \cup \left(\frac{\pi}{4}, \frac{\pi}{2}\right).$$

$$\text{Let } \cos 4\theta = 1/3$$

$$\Rightarrow \cos 2\theta = \pm \sqrt{\frac{1 + \cos 4\theta}{2}} = \pm \sqrt{\frac{2}{3}}$$

$$f\left(\frac{1}{3}\right) = \frac{2}{2 - \sec^2 \theta} = \frac{2 \cos^2 \theta}{2 \cos^2 \theta - 1} = 1 + \frac{1}{\cos 2\theta}$$

$$f\left(\frac{1}{3}\right) = 1 - \sqrt{\frac{3}{2}} \text{ or } 1 + \sqrt{\frac{3}{2}}.$$

59. Let X and Y be two events such that $P(X|Y) = \frac{1}{2}$, $P(Y|X) = \frac{1}{3}$ and $P(X \cap Y) = \frac{1}{6}$. Which of the following is (are) correct?

(A) $P(X \cup Y) = \frac{2}{3}$

(B) X and Y are independent(C) X and Y are not independent

(D) $P(X^C \cap Y) = \frac{1}{3}$

Sol. (A, B)

$$P\left(\frac{X}{Y}\right) = \frac{P(X \cap Y)}{P(Y)} = \frac{1}{2} \text{ and } \frac{P(X \cap Y)}{P(X)} = \frac{1}{3}$$

$$P(X \cap Y) = \frac{1}{6} \Rightarrow P(Y) = \frac{1}{3} \text{ and } P(X) = \frac{1}{2}$$

Clearly, X and Y are independent

$$\text{Also, } P(X \cup Y) = \frac{1}{2} + \frac{1}{3} - \frac{1}{6} = \frac{2}{3}.$$

60. If $f(x) = \int_0^x e^{t^2} (t-2)(t-3) dt$ for all $x \in (0, \infty)$, then(A) f has a local maximum at $x = 2$ (B) f is decreasing on $(2, 3)$ (C) there exists some $c \in (0, \infty)$ such that $f''(c) = 0$ (D) f has a local minimum at $x = 3$ **Sol.** (A, B, C, D)

$$f'(x) = e^{x^2} (x-2)(x-3)$$

Clearly, maxima at $x = 2$, minima at $x = 3$ and decreasing in $x \in (2, 3)$. $f'(x) = 0$ for $x = 2$ and $x = 3$ (Rolle's theorem)so there exist $c \in (2, 3)$ for which

$$f''(c) = 0.$$

