

PHYSICS

- A metal rod moves at a constant velocity in a direction perpendicular to its length. A constant, uniform magnetic field exists in space in a direction perpendicular to the rod as well as its velocity. Select the correct statement from the following
 - the entire rod is at the same electric potential
 - there is an electric field in the rod
 - the electric potential is highest at the centre for the rod and decreases towards at its ends
 - the electric potential is lowest at the centre of the rod, and increases towards its ends.
- A small circular loop of radius r is placed inside a circular loop of radius R ($R \gg r$). The loops are coplanar and their centers coincide. The mutual inductance of the system is proportional to
 - r/R
 - r^2/R
 - r/R^2
 - r^2/R^2

- The figure shows a part of a complete circuit. The potential difference $V_B - V_A$ when the current I is $5A$ and is decreasing at a rate of 10^3 As^{-1} is given by

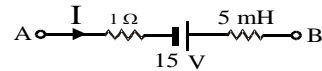

- 5 V
 - 10 V
 - 15 V
 - 20 V
- A train travelling with the speed of 90 km/hr at the north pole has axle of length 1m . If earth's magnetic field at the north pole has magnitude of $5 \times 10^{-4} \text{ T}$. The induced emf in the rod is
 - 6.25 mV
 - 12.50 mV
 - 25.50 mV
 - zero
 - A bar magnet is moved between two parallel circular loops A and B with a constant velocity v as shown in figure. Then

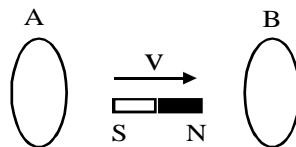

- The current in each loop flows in the same direction
- The current in each loop flows in the opposite direction
- The loops will repel each other
- The loops will vibrate.

6. A time – varying magnetic field produces an induced electric field E, then which of the following statement is wrong
- E is a non-conservative field
 - The potential of E is not defined
 - Field lines of E form closed loops
 - The field E is electrostatic
7. The figure shows a straight wire lying in the plane of the paper and a uniform magnetic field perpendicular to the plane of the paper. The ends C and D are slowly turned to form a ring of radius R so that the entire magnetic field is confined in it. The emf induced in the ring is given by

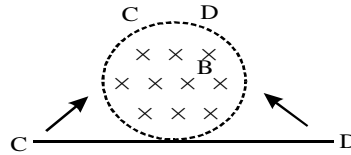

- $\frac{\pi R^2 B}{2}$
 - $\pi R^2 B$
 - zero
 - none of these
8. A semicircle conducting ring of radius R is radius in the xy plane, as shown in the figure. A uniform magnetic field is set up along the x-axis. No emf, will be induced in the ring, if

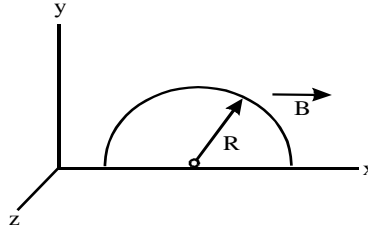

- it moves along the x-axis
 - it moves along the y-axis
 - it moves along the z-axis
 - all of these
9. There is increasing magnetic field through a conducting ring as shown in figure. The direction of induced current as seen from above the plane of coil is

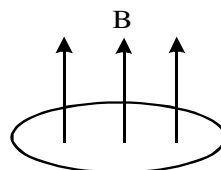

- clockwise
- anticlockwise
- no induced current
- first clockwise then anticlockwise

10. The variation of induced emf (ϵ) with time t in a coil if a short bar magnet is moved along its axis with a constant velocity is best represented as

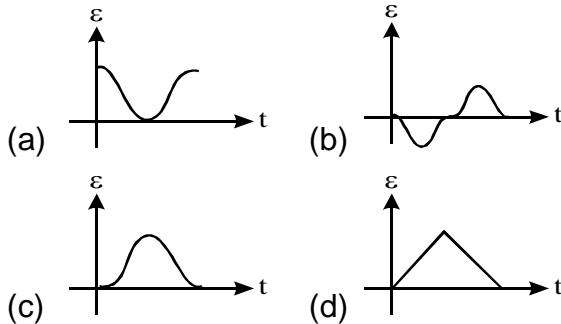

11. A coil having an inductance of $\frac{1}{\pi}$ H and a resistance of 300 ohm is connected to a 220 V, 200 Hz ac source. The phase angle between voltage and current is

- (a) $\tan^{-1}\left(\frac{3}{4}\right)$ (b) $\tan^{-1}\left(\frac{4}{3}\right)$
 (c) $\tan^{-1}\left(\frac{4}{5}\right)$ (d) $\tan^{-1}\left(\frac{5}{4}\right)$

12. In a series LCR circuit, voltage across inductor and capacitor is 500 V each. The value of resistor is 40Ω . If the applied voltage is 200 V, then the value voltage across the resistor is

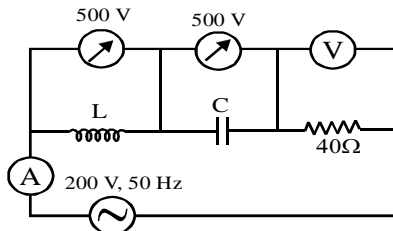

- (a) 1200 V (b) 200 V
 (c) 800 V (d) 600 V

13. For the circuit shown in figure, the current through the inductor is 0.8 A, while the current through the capacitor is 0.6 A. The current drawn from the ac source is

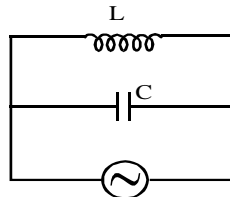

- (a) 1.2 A (b) 1.0 A
 (c) 0.6 A (d) 0.2 A

14. A parallel beam of light is incident on a converging lens parallel to its principal axis. As one moves away from the lens on the other side on its principal axis, the intensity of light
- remains constant
 - continuously increases
 - continuously decreases
 - first increases and becomes maximum at the focus then decreases
15. An object is placed at a distance of 15 cm from a convex lens of focal length 10 cm. On the other side of the lens, a convex mirror is placed at its focus such that the image coincide with the object. The focal length of the convex mirror is

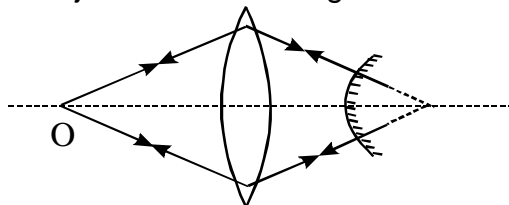

- 20 cm
 - 10 cm
 - 15 cm
 - 30 cm
16. The size of the image of an object, which is at infinity, as formed by a convex lens of focal length 30 cm is 2 cm. If a concave lens of focal length 20 cm is placed between the convex lens and the image at a distance of 26 cm from the convex lens, calculate the new size of the image
- 1.25 cm
 - 2.5 cm
 - 1.05 cm
 - 2.0 cm
17. A ray of light is incident at the glass-water interface at an angle i , it emerges finally parallel to the surface of water, then the value of μ_g would be

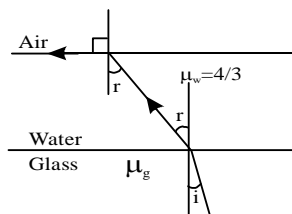

- $(4/3) \sin i$
 - $1/\sin i$
 - $4/3$
 - 1
18. When an object is at distances u_1 and u_2 from a convex lens, a real image and a virtual image is formed respectively having same magnification. The focal length of the lens is

- $u_1 - u_2$
- $\frac{u_1 - u_2}{2}$
- $\frac{u_1 + u_2}{2}$
- $u_1 + u_2$

19. An equilateral prism is silvered at one face and a monochromatic ray of light incident on unsilvered face. If light ray retraces its path then angle of incidence is (μ is the refractive index of prism)

- (a) $\sin^{-1}\left(\frac{1}{2\mu}\right)$ (b) $\sin^{-1}\left(\frac{\sqrt{3}}{2\mu}\right)$
 (c) $\sin^{-1}\left(\frac{2}{\sqrt{3}\mu}\right)$ (d) $\sin^{-1}\left(\frac{1}{\mu}\right)$

20. Two identical p-n junctions may be connected in series with a battery in three ways (figure). The potential difference across the two p-n junctions are equal in

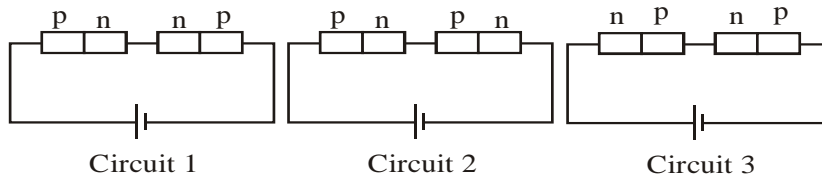

- (a) circuit 1 and circuit 2
 (b) circuit 2 and circuit 3
 (c) circuit 3 and circuit 1
 (d) circuit 1 only

21. The figure shows the wave forms for two inputs A and B and that for the output Y of a logic circuit. The logic circuit is

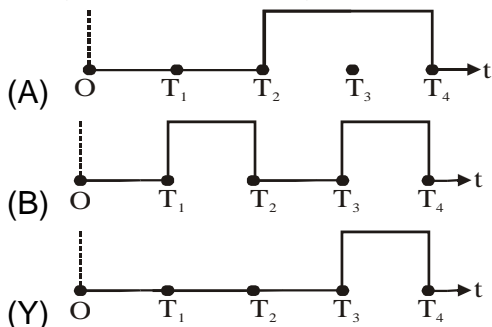

- (a) an AND gate (b) an OR gate
 (c) a NAND gate (d) a NOT gate

22. Light from a hydrogen discharge tube is incident on the cathode of a photoelectric cell. The work function of the cathode surface is 4.2 eV. In order to reduce the photo current to zero, the voltage of anode relative to the cathode must be made

- (a) -4.2 V (b) -9.4 V
 (c) -17.8 V (d) $+9.4\text{ V}$

23. Ionization energy of a hydrogen-like ion A is greater than that of another hydrogen-like ion B. Let r , u , E and L represent the radius of the orbit, speed of the electron, energy of the atom and orbital angular momentum of the electron respectively. In ground state

- (a) $r_A > r_B$ (b) $u_A > u_B$
 (c) $E_A > E_B$ (d) $L_A > L_B$

24. Which of the following statements is correct?

- (a) The current in a photocell increases with increasing frequency of light
 (b) The photo current is proportional to applied voltage
 (c) The photo current increases with the increasing intensity of light
 (d) The stopping potential increases with increasing intensity of light

25. In figure the input is across the terminals A and C and the output is across B and D. Then the output is

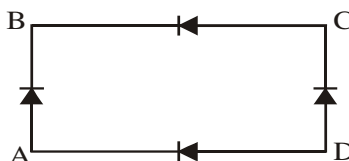

- (a) Zero (b) same as the input
 (c) half wave rectified (d) full wave rectified

26. Which of the following curves may represent the speed of the electron in a hydrogen atom as a function of the principal quantum number n ?

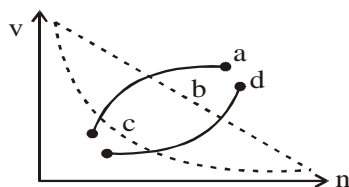

- (a) curve a (b) curve b
 (c) curve c (d) curve d

Assertion & Reason

- (a) Both A and R are true & R is correct explanation of A.
 (b) Both A and R are true but R is not correct explanation of A.
 (c) A is true but R is false.
 (d) Both A and R are false.

27. **A:** The first focal length f_1 and the second focal length f_2 of a thin lens are not always equal.

- R:** Both the focal lengths f_1 and f_2 of a lens are equal only when the medium on both the sides of a lens have same refractive index.
28. **A:** In a resistive ac circuit, current and voltage reaches their maximum value simultaneously.
R: There is no phase difference between voltage and current in ac resistive circuit.
29. **A:** Reactance is frequency dependent.
R: In a capacitive ac circuit current lags voltage.
30. **A:** In one time constant, the current grows to 37% of its maximum value in series LR circuit.
R: Current growth in series LR circuit is given by $I = I_0 e^{-\frac{R}{L}t}$.

CHEMISTRY

31. In a solid lattice the cation has left a lattice site and is located at an interstitial position, the lattice defect is
(a) Interstitial defect (b) Valency defect
(c) Frenkel defect (d) Schottky defect
32. Certain crystals produce electric signals on application of pressure. This phenomenon is called
(a) Pyroelectricity (b) Ferroelectricity
(c) Piezoelectricity (d) Ferrielectricity
33. If doubling the concentration of a reactant 'A' increases the rate 4 times and tripling the concentration of 'A' increases the rate 9 times, the rate is proportional to
(a) Concentration of 'A'
(b) Square of concentration of 'A'
(c) Under root of the concentration of the reactants
(d) Cube of concentration of 'A'
34. Which one of the following statements about the zeolites is false?
(a) they are used as cation exchangers
(b) they have open structure which enables them to take up small molecules
(c) zeolites are aluminosilicates having three dimensional network.
(d) some of the units are replaced by Na^+ and Ca^{2+} ions in zeolites.
35. In a cubic structure of compound which is made from X and Y, where X atoms are at the corners of the cube and Y at the face centres of the cube. The molecular formula of the compound is
(a) X_2Y (b) X_3Y
(c) XY_2 (d) XY_3
36. An ionic compound has a unit cell consisting of A ions at the corners of a cube and B ions on the centres of the faces of the cube. The empirical formula for this compound would be
(a) AB (b) A_2B
(c) AB_3 (d) A_3B
37. The Crystal system of a compound with unit cell dimensions $a = 0.387$, $b = 0.387$ and $c = 0.504\text{nm}$ and $\alpha = \beta = 90^\circ$ and $\gamma = 120^\circ$ is
(a) Cubic (b) Hexagonal
(c) Orthorhombic (d) Rhombohedral

38. Which of the following characteristic is wrong for physical adsorption?
- adsorption decreases with increase in temperature
 - adsorption is reversible
 - entropy decreases
 - ΔG is always +ve in physisorption
39. If values of rate constant, frequency factor and energy of activation for a reaction at temperature T are a , b & c respectively. Value of rate constant when $T \rightarrow \infty$ will be
- $be^{-c/RT}$
 - a
 - c
 - b
40. Which of the following rate laws has an overall order of 0.5 for reaction involving substances x , y and z
- Rate = $K(C_x)(C_y)(C_z)$
 - Rate = $K(C_x)^{0.5}(C_y)^{0.5}(C_z)^{0.5}$
 - Rate = $K(C_x)^{1.5}(C_y)^1(C_z)^0$
 - Rate = $K(C_x)(C_z)^n / (C_y)^2$
41. The rate constant of a reaction is $0.69 \times 10^1 \text{ min}^{-1}$ and the initial concentration is 0.2 mol l^{-1} . The half-life period is
- 400 sec
 - 600 sec
 - 800 sec
 - 1200 sec
42. A First order reaction is half completed in 45 minutes. How long does it need 99.9% of the reaction to be completed
- 5 hours
 - 7.5 hours
 - 10 hours
 - 20 hours
43. A substance 'A' decomposes by a first order reaction starting initially with $[A] = 2.00 \text{ M}$ and after 200 min $[A] = 0.15 \text{ M}$. For this reaction what is the value of k
- $129 \times 10^2 \text{ min}^{-1}$
 - $2.29 \times 10^2 \text{ min}^{-1}$
 - $3.29 \times 10^2 \text{ min}^{-1}$
 - $4.40 \times 10^2 \text{ min}^{-1}$
44. When electric current is passed through a cell containing the electrolyte + ve ions move towards the cathode and - ve ions move towards anode. If the cathode is pulled out of the solution
- + ve and - ve ions both will move towards the anode
 - + ve ions will start moving towards anode and - ve ions will stop moving

- (c) – ve ions will continue moving towards the anode and + ve ions will stop moving
 (d) + ve ions and – ve ions will start moving randomly.
45. A factory produces 40 kg of calcium in two hours by electrolysis. How much aluminium can be produced by same current in 2 hours if current efficiency is 50% in both the processes?
- (a) 22 kg (b) 18 kg
 (c) 9 kg (d) 27 kg
46. The e.m.f. of cell
 $\text{Zn(s)} \mid \text{Zn}^{2+} (0.01 \text{ M}) \parallel \text{Fe}^{2+} (0.001 \text{ M}) \mid \text{Fe(s)}$ at 298 K is 0.2905
 The value of equilibrium constant is
- (a) $e^{\frac{0.32}{0.0295}}$ (b) $10^{\frac{0.32}{0.0295}}$
 (c) $10^{\frac{0.28}{0.0295}}$ (d) $10^{\frac{0.28}{0.0295}}$
47. A weak electrolyte AB has molal conductance at infinite dilution equal to \wedge_m^∞ and molar conductance at any concentration equal to \wedge_m^1 . Hence, if C mole per litre of the electrolyte is taken in a one litre solution, then the dissociation constant of the weak electrolyte is given by
- (a) $K = \frac{C}{\wedge_m^\infty} \times \wedge_m^1$
 (b) $K = \frac{\wedge_m^1}{\wedge_m^\infty}$
 (c) $K = \frac{C(\wedge_m^1)^2}{\wedge_m^\infty(\wedge_m^\infty - \wedge_m^1)}$
 (d) $K = \frac{(\wedge_m^\infty - \wedge_m^1)}{C \wedge_m^\infty}$
48. Certain mass, say x g, of urea was dissolved in 500 g of water and cooled upto -0.5°C whereby 128 g of ice separates out from the solution. If Cryoscopic constant for water be $1.86^\circ\text{C m}^{-1}$, the value of x will be (mol mass of urea is 60)
- (a) 6 g (b) 8 g
 (c) 12 g (d) 15 g

49. A 0.001 molal solution of a complex MA_8 in water has the freezing point of -0.0054°C . Assuming 100% ionization of the complex salt and k_f for $\text{H}_2\text{O} = 1.86 \text{ K m}^{-1}$, write the correct representation for the complex.
- (a) $[MA_8]$ (b) $[MA_7]A$
(c) $[MA_6]A_2$ (d) $[MA_5]A_3$
50. Which of the following statement(s) is/are correct
- (a) A plot of $\log k_p$ vs $\frac{1}{T}$ is linear
(b) A plot of $\log A$ vs time is linear for 1st order reaction
(c) A plot of $\log P$ vs $\frac{1}{T}$ is linear at constant volume
(d) A plot of P vs $\frac{1}{V}$ is linear at constant temperature for real gas
51. Colour of KMnO_4 is decolourized without evolution of any gas. The radical present may be
- (a) SO_4^{2-} (b) SO_3^{2-}
(c) Sn^{2+} (d) Both (c) and (b)
52. The complex compounds formed when KCN solution is added to a solution containing both Cu^{2+} and Cd^{2+} ions are
- (a) $\text{K}_2[\text{Cu}(\text{CN})_4]$ and $\text{K}_2[\text{Cd}(\text{CN})_4]$ (b) $\text{K}_3[\text{Cu}(\text{CN})_4]$ and $\text{K}_2[\text{Cd}(\text{CN})_4]$
(c) $\text{K}_3[\text{Cu}(\text{CN})_4]$ and $\text{K}_3[\text{Cd}(\text{CN})_4]$ (d) $\text{K}_2[\text{Cu}(\text{CN})_4]$ and $\text{K}_3[\text{Cd}(\text{CN})_4]$
53. A gas (X) is passed through water to form a saturated solution. The aqueous solution on treatment with silver nitrate gives a white precipitate. The saturated aqueous solution dissolves magnesium ribbon with evolution of a colourless gas (Y). Identify (X) and (Y)
- (a) (X): CO_2 , (Y): Cl_2 (b) (X): Cl_2 , (Y): CO_2
(c) (X): Cl_2 , (Y): H_2 (d) (X): H_2 , (Y): Cl_2

54. An aqueous solution of a substance gives a white ppt on treatment with dilute hydrochloric acid, which dissolves on heating. When hydrogen sulphide is passed through the hot acidic solution, a black ppt is observed. The substance is

- (a) Hg_2^{2+} salt (c) Cu^{2+} salt
(b) Ag^+ salt (d) Pb^{2+} salt

55. Among the following statements, the incorrect one is

- (a) Calamite and siderite are carbonates (b) Argentite and cuprite are oxides
(c) Zinc blende and pyrites are sulphides (d) Malachite and azurite are ores of copper

56. In nitroprusside ion, the iron and NO exist as Fe^{II} and NO^+ rather than Fe^{III} and NO. These forms can be differentiated by

- (a) Estimating the concentration of iron (b) Measuring the concentration of CN^-
(c) Measuring the solid state magnetic moment (d) Thermal decomposition of the compound

57. In the standardization of $\text{Na}_2\text{S}_2\text{O}_3$ using $\text{K}_2\text{Cr}_2\text{O}_7$ by iodometry, the equivalent weight of $\text{K}_2\text{Cr}_2\text{O}_7$ is

- (a) (Molecular weight)/2 (b) (Molecular weight)/6
(c) (Molecular weight)/3 (d) Same as molecular weight

58. In the process of extraction of gold

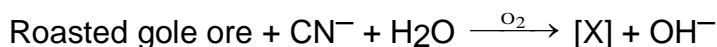

Identify the complexes [X] and [Y]

- (a) [X]: $[\text{Au}(\text{CN})_2]^-$, [Y]: $[\text{Zn}(\text{CN})_4]^{2-}$ (b) [X]: $[\text{Au}(\text{CN})_4]^{3-}$, [Y]: $[\text{Zn}(\text{CN})_4]^{2-}$
(c) [X]: $[\text{Au}(\text{CN})_2]^-$, [Y]: $[\text{Zn}(\text{CN})_6]^{4-}$ (d) [X]: $[\text{Au}(\text{CN})_4]^{2-}$, [Y]: $[\text{Zn}(\text{CN})_4]^{2-}$

59. The pair of the compounds in which both the metals are in the highest possible oxidation state is

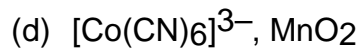
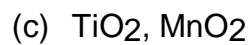
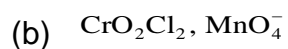
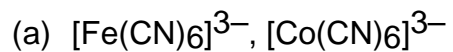

60. The pair of which salts is expected to have same colour in their freshly prepared aqueous solutions?

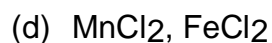
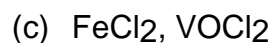
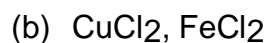
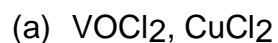

- (a) $1/3$ (b) $2/3$
(c) $2/5$ (d) $3/5$

68. The value of
$$\begin{vmatrix} \sqrt{3} + \sqrt{13} & 2\sqrt{5} & \sqrt{5} \\ \sqrt{15} + \sqrt{26} & 5 & \sqrt{10} \\ 3 + \sqrt{65} & \sqrt{15} & 5 \end{vmatrix}$$
 is :

- (A) $\sqrt{3} (\sqrt{6} - 5)$ (B) $5\sqrt{3} (\sqrt{6} - 5)$
(C) $5\sqrt{3} (\sqrt{6} + 5)$ (D) $5 (\sqrt{6} - 5)$

69. If $a + b + c > 0$ and $a \neq b \neq c \neq 0$, then $\Delta = \begin{vmatrix} a & b & c \\ b & c & a \\ c & a & b \end{vmatrix}$ then :

- (A) $\Delta > 0$ (B) $\Delta < 0$
(C) $\Delta = 0$ (D) Data insufficient

70. The determinant $\Delta = \begin{vmatrix} a & b & a\alpha + b \\ b & c & b\alpha + c \\ a\alpha + b & b\alpha + c & 0 \end{vmatrix}$ is equal to zero if :

- (A) a, b, c are in A.P. (B) a, b, c are in G.P.
(C) a, b, c are in H.P. (D) none of these

71.
$$\begin{vmatrix} 103 & 115 & 114 \\ 111 & 108 & 106 \\ 104 & 113 & 116 \end{vmatrix} + \begin{vmatrix} 113 & 116 & 104 \\ 108 & 106 & 111 \\ 115 & 114 & 103 \end{vmatrix}$$
 is equal to :

- (A) a positive number (B) a negative number
(C) Zero (D) none of these

72. If $f(x) = \begin{vmatrix} \cos x & 1 & 0 \\ 1 & 2\cos x & 1 \\ 0 & 1 & 2\cos x \end{vmatrix}$, then $\int_0^{\pi/2} f(x) dx$ is equal to :

- (A) $1/4$ (B) $-1/3$
(C) $1/2$ (D) 1

73. For positive numbers x, y, z , the numerical value of the determinant

$$\begin{vmatrix} 1 & \log_x y & \log_x z \\ \log_y x & 1 & \log_y z \\ \log_z x & \log_z y & 1 \end{vmatrix} \text{ is :}$$

- (A) 0 (B) 1
(C) 2 (D) none of these

74. If A, B, C are the angles of a triangle then

$$\begin{vmatrix} 1 & \cos(A-B) & \cos(A-C) \\ \cos(B-A) & 1 & \cos(B-C) \\ \cos(C-A) & \cos(C-B) & 1 \end{vmatrix} \text{ is equal to :}$$

- (A) 0 (B) 1
(C) -1 (D) none of these

75. If $f(x) = \begin{vmatrix} 1 & x & x+1 \\ 2x & x(x-1) & (x+1)x \\ 3x(x-1) & x(x-1)(x-2) & (x+1)x(x-1) \end{vmatrix}$ then $f(100)$ is equal to :

- (A) 0 (B) 1
(C) 100 (D) -100

76. $\begin{vmatrix} a^2+1 & ab & ac \\ ba & 1+b^2 & bc \\ ca & cb & 1+c^2 \end{vmatrix}$ is equal to :

- (A) $1 + \sum a^2$ (B) $\sum a^2$
(C) $(\sum a)^2$ (D) $\sum a$

77. If A, B, C are the angles of a triangle and $\Delta = \begin{vmatrix} \sin^2 A & \cot A & 1 \\ \sin^2 B & \cot B & 1 \\ \sin^2 C & \cot C & 1 \end{vmatrix}$, then Δ is

equal to:

- (A) constant other than zero (B) not a constant
(C) 0 (D) none of these

78. If $[.]$ denotes the greatest integer less than or equal to the real number under consideration and $-1 \leq x < 0$; $0 \leq y < 1$ and $1 \leq z < 2$, then the

value of the determinant $\begin{vmatrix} [x]+1 & [y] & [z] \\ [x] & [y]+1 & [z] \\ [x] & [y] & [z]+1 \end{vmatrix}$ is :

- (A) $[z]$ (B) $[y]$
(C) $[x]$ (D) none of these

79. If $\Delta = \begin{vmatrix} x+a & b & c \\ a & x+b & c \\ a & b & x+c \end{vmatrix} = 0$, then the non zero root of the equation

is :

- (A) $a+b+c$ (B) abc
(C) $-a-b-c$ (D) None of these

80. If I_n is the identity matrix of order n , then $(I_n)^{-1}$
(A) does not exist (B) equal to I_n
(C) equals to O (D) nI_n

81. If $A [a_{ij}]$ is a square matrix of order $n \times n$ such that $a_{ii} = k$ for all i , then trace of A is equal to

- (A) k^n (B) $\frac{n}{k}$
(C) nk (D) none of these

82. If $A = \begin{bmatrix} 1 & 0 \\ -1 & 7 \end{bmatrix}$ and $I = \begin{bmatrix} 1 & 0 \\ 0 & 1 \end{bmatrix}$, then the value of k so that $A^2 = 8A + kI$ is
(A) 7 (B) -7
(C) 0 (D) 5

83. If $A = \begin{bmatrix} a & 0 & 0 \\ 0 & a & 0 \\ 0 & 0 & a \end{bmatrix}$, then the value of $|\text{adj } A|$ is
(A) a^{27} (B) a^9
(C) a^6 (D) a^2

84. If A and B are symmetric matrices of order n ($A \neq B$), then
 (A) $A + B$ is skew symmetric (B) $A + B$ is symmetric
 (C) $A + B$ is a diagonal matrix (D) $A + B$ is a zero matrix
85. If $A = \begin{bmatrix} 1 & 1 & 3 \\ 5 & 2 & 6 \\ -2 & -1 & -3 \end{bmatrix}$ the A is
 (A) Idempotent (B) nilpotent
 (C) symmetric (D) none of these
86. The distance between the line $\frac{x-1}{3} = \frac{y+2}{-2} = \frac{z-1}{2}$ and the $2x + 2y - z = 6$ plane is
 (a) 9 (b) 1 (c) 2 (d) 3
87. If a plane passes through the point (1,1,1) and is perpendicular to the line $\frac{x-1}{3} = \frac{y-1}{0} = \frac{z-1}{4}$, then its perpendicular distance from the origin is
 (a) $\frac{3}{4}$ (b) $\frac{4}{3}$ (c) $\frac{7}{5}$ (d) 1
88. A plane which passes through the point (3, 2, 0) and the line $\frac{x-3}{1} = \frac{y-6}{5} = \frac{z-4}{4}$ is
 (a) $x - y + z = 1$ (b) $x + y + z = 5$ (c) $x + 2y - z = 0$ (d) $2x - y + z = 5$
89. The point of intersection of the line $\frac{x-1}{3} = \frac{y+2}{4} = \frac{z-3}{-2}$ and plane $2x - y + 3z - 1 = 0$ is
 (a) (10, -10, 3) (b) (10, 10, -3) (c) (-10, 10, 3) (d) None of these
90. The co-ordinates of the foot of perpendicular drawn from point $P(1, 0, 3)$ to the join of points $A(4, 7, 1)$ and $B(3, 5, 3)$ is
 (a) (5, 7, 1) (b) $\left(\frac{5}{3}, \frac{7}{3}, \frac{17}{3}\right)$ (c) $\left(\frac{2}{3}, \frac{5}{3}, \frac{7}{3}\right)$ (d) $\left(\frac{5}{3}, \frac{2}{3}, \frac{7}{3}\right)$