

Sl. No.

47032

A-FRF-M-DOB

ELECTRICAL ENGINEERING**PAPER II**

(CONVENTIONAL)

Time Allowed : Three Hours

Maximum Marks : 200

INSTRUCTIONS

Please read each of the following instructions carefully before attempting questions

Candidates should attempt FIVE questions in all. Question No. 1 is compulsory. The remaining FOUR questions are to be attempted by selecting at least ONE question from each of the three Sections A, B and C.

All questions carry equal marks. The number of marks carried by a part of a question is indicated against it.

Answers must be written in ENGLISH only.

Unless otherwise mentioned, symbols and notations have their usual standard meanings. Assume suitable data, if necessary and indicate the same clearly.

Neat sketches may be drawn, wherever required.

All parts and sub-parts of a question are to be attempted together in the answer book.

Any pages left blank in the answer book must be clearly struck out.



1. All parts carry equal marks. 10x4

- (a) A 220 V DC shunt motor takes 20 A at full load running at 2500 rpm. The armature resistance is 0.4Ω and shunt field resistance of 176Ω . The machine is converted into a long shunt differentially compound motor by augmenting an additional series field winding with 0.1Ω resistance. There is a 11% change in the total flux when compound motor develops the same torque. Assume rotational losses to be constant under all loading conditions. 4
- (b) A 240 V, 50 Hz, 2 pole universal motor operates at a speed of 10000 rpm on full load and draws a current of 7.12 A at 0.92 lagging power factor. The motor parameters are $r_a = 6.34 \Omega$; $x_a = 9.62 \Omega$; $r_s = 4.89 \Omega$; $X_s = 3.6 \Omega$. Calculate efficiency of the motor if rotational losses are 60 W. 4
- (c) A generator is supplying 2000 MW to an infinite bus via a transmission line of reactance 0.1 p.u. The base MVA is 1000 MVA and both terminal voltage and infinite bus voltage are at 1 p.u. Find the reactive power supplied by the machine to the infinite bus. 4
- (d) What is the problem with load encroachment in case of distance protection through mho relay. 4
- (e) Where and why do we use negative sequence relay in a power system? 4

- (f) Define slew-rate and PSRR of an operational Amplifier. Explain clearly the difference between Bandwidth, transient response and slew-rate of an op-Amp. 4
- (g) The efficiency of rectification η_r is defined as the ratio of the dc output power $P_{dc} = V_{dc} I_{dc}$ to the input power

$$\left(\frac{1}{2\pi}\right) \int_0^{2\pi} v_i i d\alpha;$$

show that for the full wave-rectifier circuit

$$\eta_r = \frac{81.2}{1 + \frac{R_F}{R_L}} \% \quad 4$$

(h)

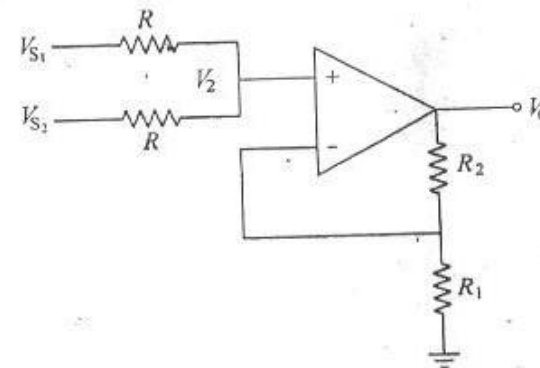

Find an expression for the output V_O of the amplifier circuit shown above. Assume an ideal op-Amp. What mathematical operation does the circuit perform? 4

- (i) A three phase diode rectifier connected to 415 V line to line source and feed a resistive load of 25Ω . Assume drawl of balanced quasi square waveform currents in the three phases, the distortion factor given to be $\frac{3}{\pi}$. Compute power drawn at fundamental frequency from mains. 4
- (j) A thyristor string is formed by series and parallel connection of thyristors. The voltage and current ratings of the string are 11 kV, 4 kA respectively. The thyristor to be employed has voltage and current ratings of 1.7 kV, 1 kA. The string efficiency is 90% for both series and parallel combinations. If the maximum blocking current is 15 mA and max charge storage (ΔQ_{\max}) is 24 micro coulombs (μC), calculate the value of resistance and capacitance of equalizer circuit. 4

Section - A

(Attempt at least *one* question)

2. (a) Three single phase transformers, each rated at 11 kVA, 220/440 V 50 Hz are connected to form a three phase step up, Y/ Δ connection. The parameters of each transformers are

$$\begin{aligned} (220 \text{ V}) \text{ Primary side} &: r_1 = 39.5 \text{ m}\Omega; \\ &x_1 = 61.5 \text{ m}\Omega; \\ &R_c = 240 \Omega; \\ &x_\phi = 290 \Omega. \end{aligned}$$

$$\begin{aligned} (440 \text{ V}) \text{ Secondary side} &: r_2 = 133.5 \text{ m}\Omega; \\ &x_2 = 201 \text{ m}\Omega. \end{aligned}$$

What will be power rating and efficiency of the transformer in Y/ Δ connection, when it delivers the rated load at rated voltage and 0.8 pf lagging. 20

- (b) Discuss briefly various speed control techniques for Induction motors (both squirrel cage and wound rotor types). 10
- (c) A 44 MVA, 10.5 kV, 50 Hz, Y connected three phase salient pole synchronous generator has $x_d = 1.83 \Omega$ and $x_q = 1.21 \Omega$. It delivers the rated load at 0.8 pf lagging. The armature resistance is negligible determine the power developed by the generator and % voltage regulation. 10
3. (a) A 400 V, Y connected, 3 phase, 6 pole 50 Hz wound rotor induction motor has following parameters referred to the stator
- $$r_1 = r_2' = 1 \Omega; x_1 = x_2' = 2 \Omega.$$
- Stator to rotor turns ratio = 2.3.



(i) For regenerative braking at what speed the motor will hold an overhauling torque of 100 Nm.

(ii) For plugging operation the initial full load speed is 950 rpm. The motor is braked by inserting additional resistance in the rotor circuit during plugging so as to reduce the braking current to 1.5 times its full load current. Compute the external resistance and initial braking torque. 20

(b) Two DC series motors with different air gaps but otherwise identical run at 700 and 750 rpm respectively, when taking 50 A at 500 V. The total resistance of each motor is 0.36Ω . If the motors are now mechanically coupled and connected in series electrically to a 500 V DC supply and together takes 50 A current. Calculate the speed at which the coupled set will run. 10

(c) Draw neat phasor diagrams and $T-s$ characteristics of single phase capacitor run, capacitor start-capacitor run, capacitor start motors. Compare their performance on the basis of these characteristics. 10

Section - B

(Attempt at least one question)

4. (a)

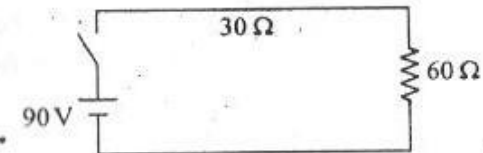

For the above circuit find the voltage at the receiving end just before $5T$ where T is the time taken by the voltage wave to travel the length of the line. 10

(b) For the case of opening a lightly loaded long transmission line through a CB, explain and specify what can be the maximum voltage that can remain across the transmission line after opening of the CB. 10

(c) The sending end rated voltage of a 3- ϕ , 300 KM transmission line is 400 KV. It has $Z_c = 400 \Omega$ and $\beta = 0.002$ rad/km and is operating at no load. Find out the reactance and its rating that need to be connected in shunt to make the receiving end voltage same as sending end voltage. 10

(d) Discuss about the three zone protection of EHV transmission line. 10

5. (a)

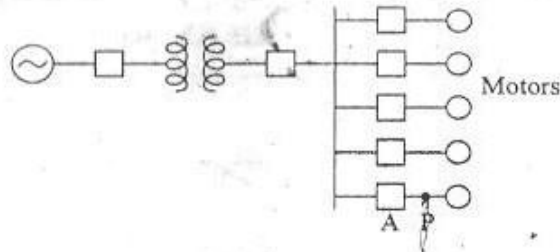

A 20 MVA 11 KV generator with $X_d'' = 15\%$ is connected through a transformer to a bus which supplies five identical motors as given above.

The subtransient reactance X_d'' of each motor is 20% on the base of 5000 KVA, 6.6 KV. The 3- ϕ rating of the transformer is 25000 KVA, 11 KV/6.6 KV with leakage reactance of 10%. The bus voltage at the motor is 6.6 KV when a 3- ϕ fault occurs at point P.

Calculate the subtransient current through the breaker A utilising the Z bus matrix. 20

(b) A system consists of two plants connected by a transmission line. The only load is located at plant 2. When 200 MW is transmitted from plant 1 to plant 2 power loss in the line is 16 MW. Find the required generation for each plant and the power received by the load when λ for the system is \$ 12.50/MW-hr. Assume that the incremental fuel costs can be approximated to be

$$\frac{dF_1}{dP_1} = 0.010P_1 + 8.5 \text{ \$/MWh.}$$

$$\frac{dF_2}{dP_2} = 0.015P_2 + 9.5 \text{ \$/MWh.} \quad 20$$

Section - C

(Attempt at least one question)

Q. (a) (i) Explain briefly the early effect phenomenon in BJT. 5

(ii)

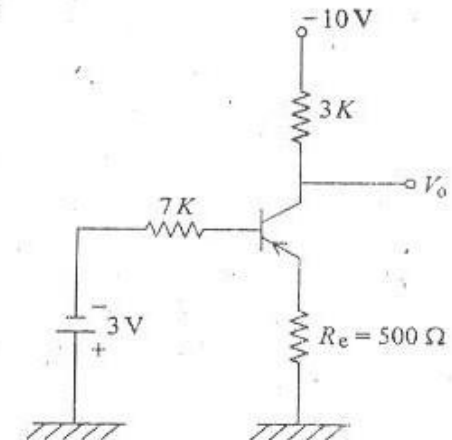

For the circuit shown above

$$\beta = h_{FE} = 100$$

Calculate

- (1) Verify if the transistor is in cut off, saturation or in the active region
- (2) Find V_o 15

(b) Write an 8085 assembly language program to perform a parity check on an 8-bit word in location 4000_{16} . If the parity is ODD, store DD_{16} in location 4000_{16} . However if the parity is EVEN, store EE_{16} in location 4000_{16} . 10

(c) (i) Define XNOR gate and write the truth table for exclusive-NOR (XNOR) gate. 5

(ii) Design a circuit to perform XNOR logic using only NOR gates. 5

7. (a) A full bridge inverter (IGBT) has a switching sequence which produces a square wave voltage across a series R-L load. For the instant case the switching frequency is 50 Hz. $V_{dc} = 100$ V, $R = 10 \Omega$ and $L = 25$ mH. Determine the amplitude of the fourier series terms for load current and the power absorbed by the load. Consider only 3rd, 5th and 7th harmonic terms. Compute THD for voltage and current. If the switching sequence is modified to produce quasi square waveform, what changes will be observed in fourier coefficients and THD of voltage waveform and currents. 20

(b) A capacitor is connected across an ac regulator feeding inductor (TCR). Input is at 230, 50 Hz and inductive reactance (X_L) = 10Ω ; capacitive reactance (X_C) = 10Ω . Calculate the net VAR supplied by the circuit at $\alpha = 135^\circ$. 10

(c) Draw a neat diagram for a four quadrant chopper employing self commutated switches, feeding the armature of a DC motor (separately excited type). Explain through voltage and current waveforms the working for both duty ratio greater than and less than 0.5. 10