

Serial No.

82129

A-FRF-M-DSA

**ELECTRONICS AND
TELECOMMUNICATION ENGINEERING
Paper—I
(Conventional)**

Time Allowed : Three Hours

Maximum Marks : 200

INSTRUCTIONS

Please read each of the following instructions carefully before attempting questions :

Candidates should attempt FIVE questions in all. Question No. 1 is compulsory. Out of the remaining SIX questions attempt any FOUR.

All questions carry equal marks. The number of marks carried by a part of a question is indicated against it.

Answers must be written in ENGLISH only.

Assume suitable data, if necessary and indicate the same clearly.

Unless otherwise mentioned, symbols and notations have their usual standard meanings.

Values of the following constants may be used as indicated wherever necessary :

Electronic charge = -1.6×10^{-19} coulomb

Free space permeability = $4 \pi \times 10^{-7}$ Henry/m

①

Free space permittivity = $(1/36\pi) \times 10^{-9}$ Farad/m

Velocity of light in free space = 3×10^8 m/s

Boltzmann constant = 1.38×10^{-23} J/K

Planck constant = 6.626×10^{-34} J-s

Neat sketches may be drawn, wherever required.

All parts and sub-parts of a question are to be attempted together in the answer book.

Any pages left blank in the answer book must be clearly struck out.

1. (a) (i) What are ferroelectric materials ? What advantages do they have over conventional dielectric materials ? 3
- (ii) Give one example each of a dielectric and a ferroelectric material having high relative permittivity (ϵ_r). 2
- (b) P-n junction transistors can be fabricated using the materials Germanium and Silicon. However silicon is preferred to Germanium. Explain. 5
- (c) Find the power spectral density if autocorrelation function is given as :
 $R_x(\tau) = e^{-\alpha|\tau|}$ for $-\infty < \tau < \infty$. 5

(2)

(Contd.)

- (d) Find v_1 and v_2 by writing a single supernode equation for the given circuit. 5

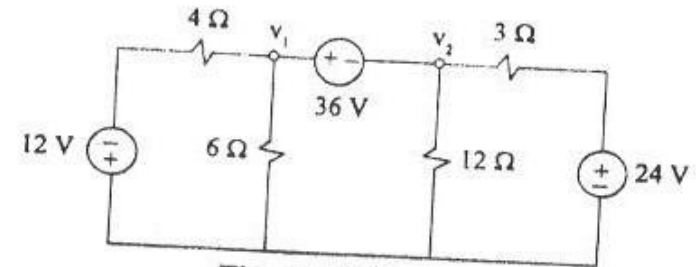

Fig. Q. 1(d)

- (e) Two concentric spherical shells ($r_1 = 5$ cm and $r_2 = 30$ cm) are applied with -10 V and $+120$ V respectively. The dielectric medium between the shells has $\epsilon_r = 2.2$. Find the charge densities. Determine the location where the $V = 50$ V. 5
- (f) Three signals (0.1 GHz, 1 GHz and 10 GHz) are available for propagation. Will it be possible to send all of them through a parallel plate air filled waveguide with a separation of 12 cm between the plates ? 5
- (g) In an oscilloscope X- and Y-signals both are saw-tooth waves of same amplitudes and time periods but different phase angles. If Y-input is leading the X-input by 90° , draw the pattern traced on the CRO screen. Take the saw-tooth signals with positive slopes. 5

(3)

(Contd.)

(h) (a') Explain in brief the working of the circuit shown when :

- (i) the switch S_1 is ON
- (ii) S_1 is OFF.

(b') What will be the output V_o when V_i is $5 \sin 100 \pi t$ and :

- (i) S_1 is OFF $\begin{cases} S_2 \text{ ON} \\ S_2 \text{ OFF} \end{cases}$
- (ii) S_1 is ON $\begin{cases} S_2 \text{ ON} \\ S_2 \text{ OFF} \end{cases}$

5

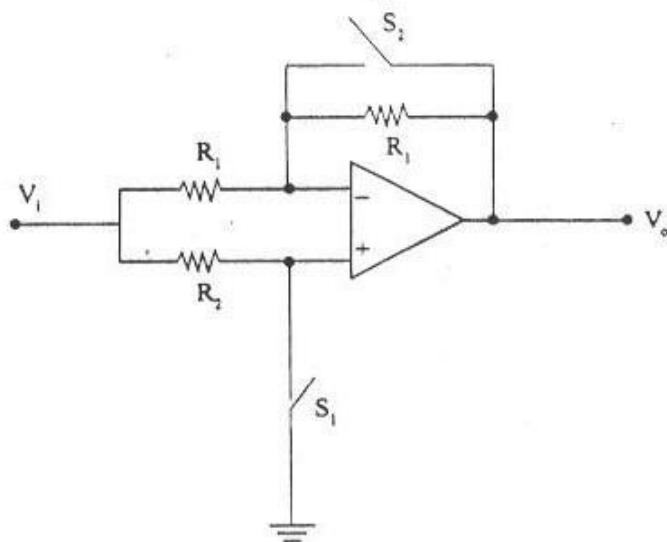

Fig. Q. 1(h)

④

(Contd.)

2. (a) What are the expressions for series and parallel resonances of the equivalent circuit of a quartz crystal oscillator ? 5
- (b) A quartz crystal oscillator has an equivalent inductance of $L = 10 \text{ mH}$ and series and parallel capacitances of $C_s = 10 \mu\text{F}$ and $C_p = 10 \mu\text{F}$. Find the series and parallel resonant frequencies of this oscillator. 5
- (c) Show schematically the static characteristics of a thyristor identifying clearly various regions. 5
- (d) What is a direct band gap and an indirect band gap semiconductor ? 5
- (e) Explain why a silicon diode can not be used as a LED but it is useful as a photodiode ? 5
- (f) If Si diode is used as a photodiode find the maximum value of responsivity and maximum wavelength upto which it can be used. 10
- (g) A magnetically levitated train travels between the city centre and the airport in Shanghai, China. Which peculiar property of superconductivity is taken advantage of in this application ? 5

⑤

(Contd.)

3. (a) A zener diode regulates at 50 V over a range of diode currents from 5 mA to 40 mA. Supply voltage $V = 200$ V.

(i) Calculate the value of R to allow voltage regulation from a load current $I_L = 0$ upto $I_{L_{max}}$, the maximum possible value of I_L .

(ii) What is $I_{L_{max}}$?

(b) A half wave rectifier having a diode with an internal resistance of 20Ω is to supply power to a $1 \text{ k}\Omega$ load from a 110 V (rms) source of supply.

Do the following :

(a) Draw a schematic that represents the above description of the circuit.

Also calculate :

(b) Peak load current

(c) DC load current

(d) AC load current

(e) DC diode voltage. 10

6

(Contd.)

(c) For the circuit shown, neglecting base currents find I_0 and I_1, I_2, I_3 . 10

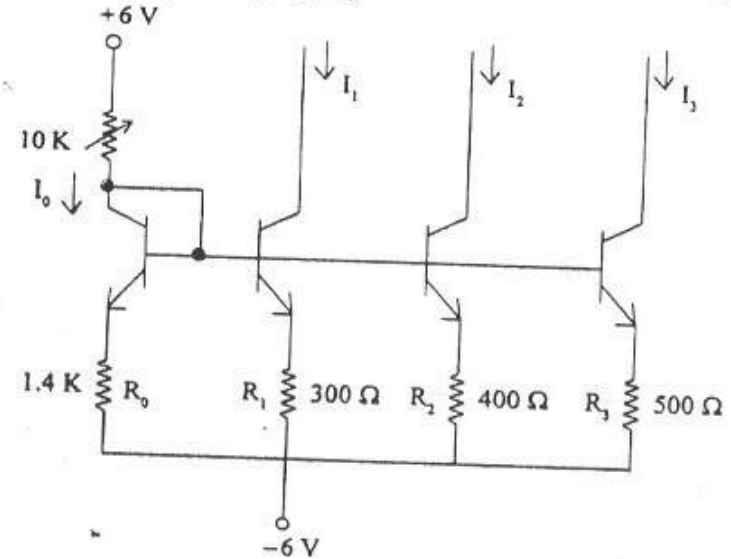

Fig. Q. 3(c)

(d) In the following circuit :

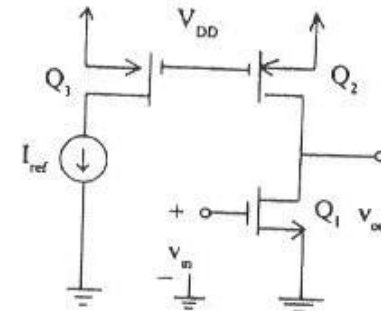

Fig. Q. 3(d)

7

(Contd.)

if $V_{DD} = 10 \text{ V}$, $V_{tn} = |V_{tp}| = 1 \text{ V}$, $\mu_n C_{ox} = 2 \mu_p C_{ox} = 20 \mu\text{A/V}^2$, $W = 100 \mu\text{m}$, $L = 10 \mu\text{m}$ and $|V_A| = \text{Early voltage} = 100 \text{ V}$ both for n and p devices, $I_{ref} = 100 \mu\text{A}$, find the small signal voltage gain. 10

4. (a) Find the energy E_x of the signal $x(t) = e^{-at} u(t)$. Determine the frequency W (rad/sec) so that the energy contributed by the spectral components of all frequencies below W is 95% of the signal energy. 10

(b) Given that $X(w)$ is the Fourier transform of $x(t)$. Find the Fourier transform of following in terms of $X(w)$:

(i) $x_1(t) = x(1 - t) + x(-1 - t)$

(ii) $x_2(t) = x(4t - 5)$

(iii) $x_3(t) = \frac{d^2x}{dt^2}(t-1)$ 10

- (c) The output $y(t)$ of a continuous time LTI system is found to be $3e^{-4t} u(t)$ when the input $x(t)$ is $u(t)$.
- (i) Find the impulse response $h(t)$ of the system.
 - (ii) Find the output $y(t)$ when the input $x(t)$ is $e^{-t} u(t)$. 10
- (d) Consider the discrete time system as shown in the figure below.

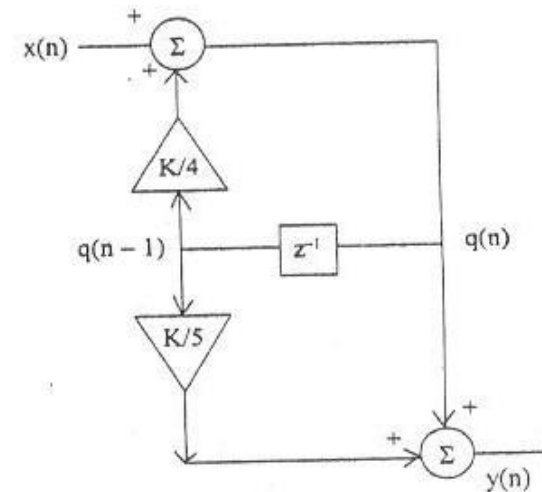

Fig. Q. 4(d)

For what value of K is the system BIBO stable ?

10

5. (a) State and prove maximum power transfer theorem for a circuit with source V_S and source resistance R_S and a variable load resistance R_L . 10
- (b) If R_L is fixed and R_S is varied will the formula be valid? Prove. 10
- (c) For the circuit shown determine Z_L that will draw maximum power from the source. 10

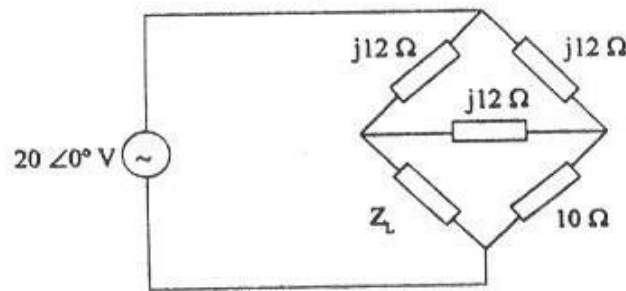

Fig. Q. 5(c)

- (d) Determine the h-parameters of the network shown. 10

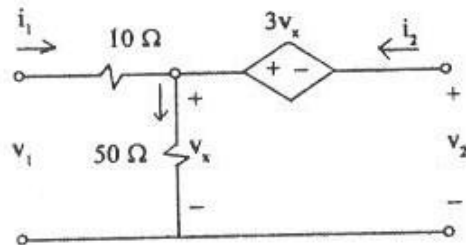

Fig. Q. 5(d)

⑩

(Contd.)

6. (a) A pair of isolated parallel power lines of 1 cm radius with a separation of 90 cm have a voltage difference of 440 V. These power lines are 60 cm above a pair of telephone lines. Find the voltage difference between the telephone lines due to induction from power lines. The telephone lines are separated by 20 cm. 10
- (b) Two coils kept on a common axis are separated by 12 cm. Coil A has 10 turns of radius 4 cm with a current of 1 A. Coil B has 5 turns of wire with a radius of 6 cm. The current in Coil B is to be determined such that the induced magnetic field due to this current cancels the magnetic field at the center of Coil A generated by Coil A. 10

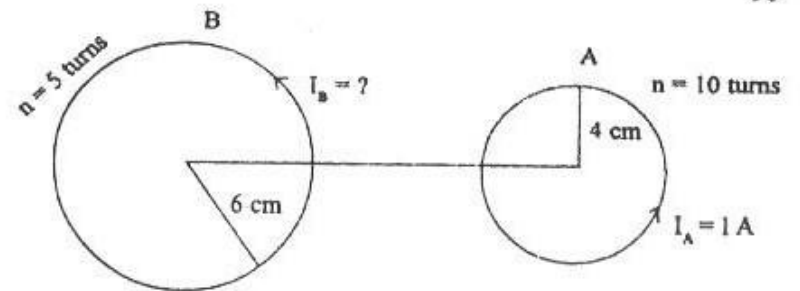

Fig. Q. 6(b)

⑪

(Contd.)

- (c) Derive the expression for the power required to move a current carrying conductor at a rotational frequency of N -rev/min if it is placed in a magnetic field of flux density $B_0 \hat{a}_r$. Find the value with the given data : $B_0 = 0.6$ T; $I = 10$ A; $L = 1.2$ m; $N = 25$ rev/min, $r = 2$ cm. From this determine the magnetic flux density to be applied if the power is to be 1.5 W. 10

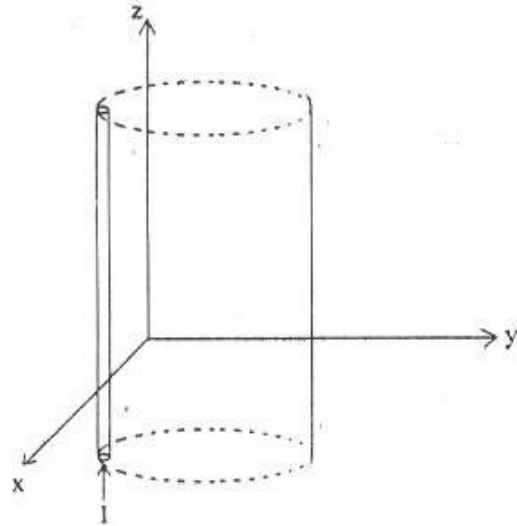

Fig. Q. 6(c)

- (d) A plane wave travelling in the $+z$ direction in free space ($z < 0$) is normally incident at $z = 0$ on a conductor ($z > 0$) for which $\sigma = 61.7$ MS/m,

(12)

(Contd.)

$\mu_r = 1$. The free space wave has a frequency of 2.5 MHz. The \vec{E} field amplitude is 1.5 V/m at the interface. Find the expression for \vec{H} in the conductor. 10

7. (a) In the circuit shown, R is a resistive transducer. The bridge is balanced and the output, $V_o = 0$ when $R_3 = R$. Now R is changing in response to a physical variable. Show that the output voltage

$$V_o = V_R \left(1 + \frac{R_2}{R_1} \right) \frac{\Delta R}{2R + \Delta R}$$

where ΔR is the change in the value of R . 20

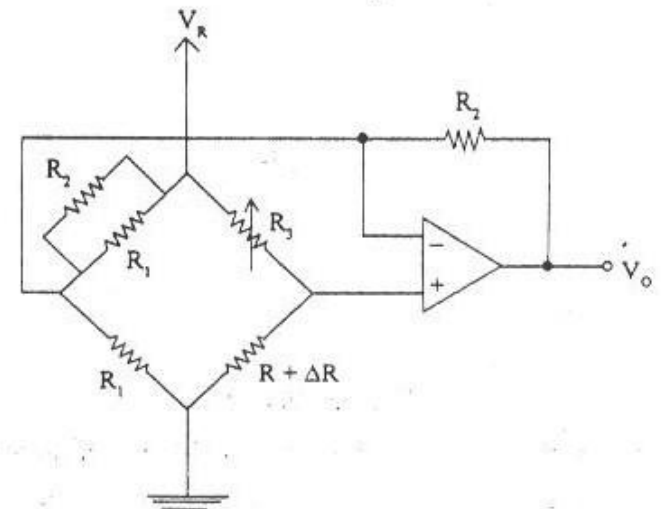

Fig. Q. 7(a)

(13)

(Contd.)

- (b) In the circuit shown, the output voltage is found to be 25 mV. If the optical power input is at a wavelength, $\lambda = 1.32 \mu\text{m}$ calculate the optical power in μW . Take the quantum efficiency of the photo-diode to be 65%. 10

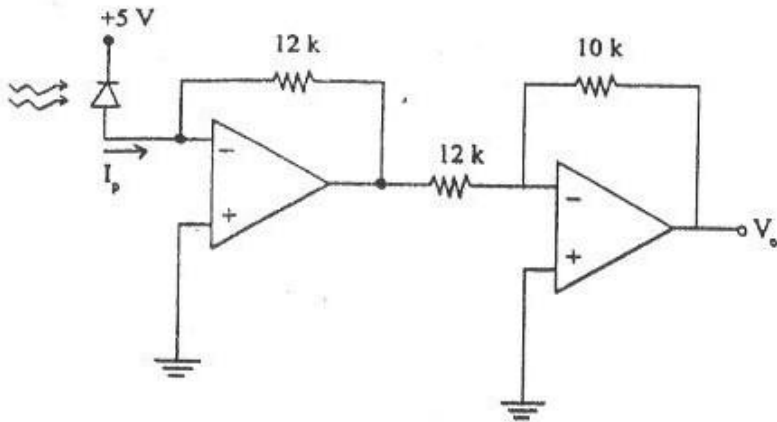

Fig. Q. 7(b)

- (c) Overall quantum efficiency of GaAs light emitting diode shown in the circuit is 70%. ON state diode voltage is 1.8 V. V_i is a binary signal with $V(1) = 5 \text{ V}$ and $V(0) = 0 \text{ V}$. Find the logic levels

(14)

(Contd.)

- of the optical binary output. Take band-gap energy for GaAs = 1.43 eV. 10

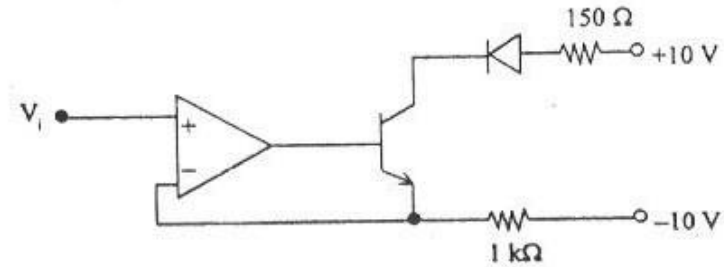

Fig. Q. 7(c)

(15)