

Sl. No.

69305

A-FRF-M-DSB

**ELECTRONICS AND  
TELECOMMUNICATION  
ENGINEERING****PAPER II  
(CONVENTIONAL)****Time Allowed : Three Hours****Maximum Marks : 200****INSTRUCTIONS**

**Please read each of the following instructions carefully before attempting questions**

*Candidates should attempt FIVE questions in all.*

*Question No. 1 is compulsory. Out of the remaining SIX questions attempt any FOUR.*

*All questions carry equal marks. The number of marks carried by a part of a question is indicated against it.*

*Answers must be written in ENGLISH only.*

*Assume suitable data, if necessary and indicate the same clearly.*

*Unless otherwise mentioned, symbols and notations have their usual standard meanings.*

*Neat sketches may be drawn, wherever required.*

*All parts and sub-parts of a question are to be attempted together in the answer book.*

*Any pages left blank in the answer book must be clearly struck out.*

1. (a)

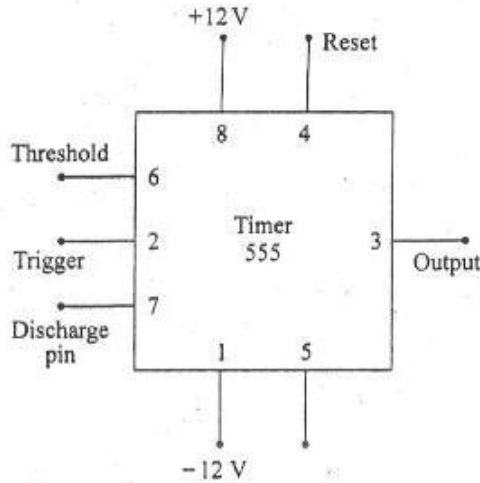

In the IC Timer 555 shown in the above figure determine the reference levels for the two comparators inside the chip. Justify your answer by drawing a block diagram of the internal circuit of IC Timer 555. 5

(b)

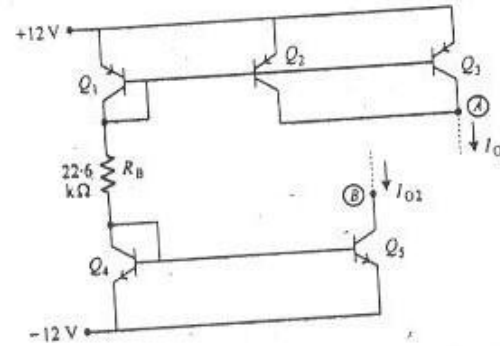

Assuming matched transistors with large  $\beta$  (i.e. negligible base currents), determine the currents  $I_{O1}$  and  $I_{O2}$  in the circuit given in the above figure. Assume that nodes B and A are connected at appropriate voltages which ensure that transistors  $Q_3$ ,  $Q_2$  and  $Q_1$  are in active region. 5

(c) Find the minimum expression of  $Y = \pi m (0, 1, 3, 5, 6, 7, 10, 14, 15)$  in product-of-sum (POS) form. 5

(d)

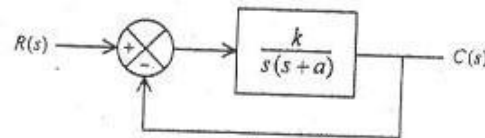

If the resonant peak ( $M_r$ ) and resonant frequency ( $\omega_r$ ) of the closed-loop frequency-response of the system given above are  $M_r = 1.04$  and  $\omega_r = 11.55$  rad/sec, find the values of  $k$  and  $a$ . 5

(e) Find the ratio of stimulated emission rate to the spontaneous emission rate operating at a temperature of  $200^\circ\text{C}$  and the average operating wavelength is  $1 \mu\text{m}$ . 5

(f) An optical fibre with a core diameter  $2 \mu\text{m}$  and core refractive index of  $1.48$  and a cladding refractive index of  $1.46$ . Determine

(i) the critical angle at the core-cladding interface,

(ii) the numerical aperture for the fibre. 5

(g) Give the Energy-band diagram for three valley model for InP Gunn-diode. Also compare the peak to valley current ratio for  $n$ -type GaAs and  $n$ -type InP. Why InP diode is superior to GaAs diode? 2+2+1

(h) Convert Hexadecimal number A5F1 to equivalent octal number. 5

2. (a)

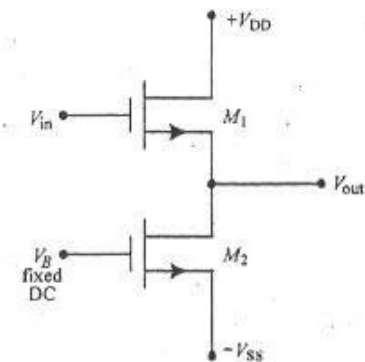

The above figure shows a source follower using  $m$ -channel MOSFETs. Assuming that  $M_1$  and  $M_2$  both are in saturation and have different transconductance parameters  $K_1$  and  $K_2$  where  $K_i = \frac{\mu_n \text{cox}}{2} \left( \frac{W}{L} \right)_i$ ;  $i = 1, 2$  and symbols have their usual meaning. Derive an expression for  $V_{out}$ , in terms of  $V_{in}$ ,  $V_{DD}$ ,  $V_S$ ,  $V_B$ ,  $V_{th}$  and  $K_1, K_2$ . Find out the small signal voltage gain and DC offset voltage appearing at the output. 10

(b)

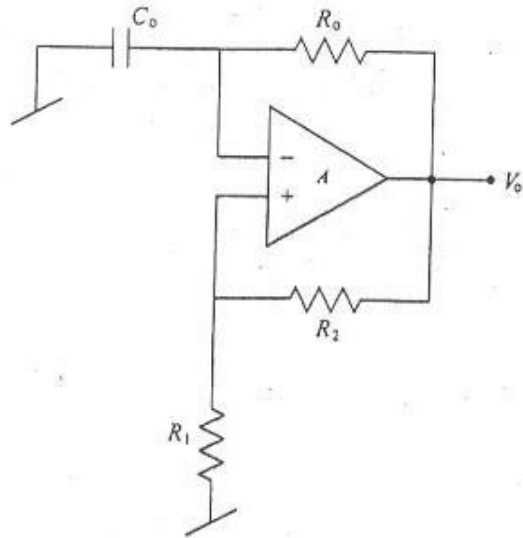

Assuming the gain  $A$  of the op-amp to be represented by  $A \cong \frac{\omega_f}{s}$  where  $\omega_f$  is the gain-bandwidth-product of the op-amp, analyze the given circuit and determine under what condition, the circuit can generate sinusoidal signal at the output? What is the frequency of the output waveform if  $R_1 = 1\text{ K}\Omega$ ,  $R_2 = 9\text{ K}\Omega$ ,  $C_0 = 0.1\ \mu\text{F}$  and  $R_0 = 10\text{ K}\Omega$ ?

(c)

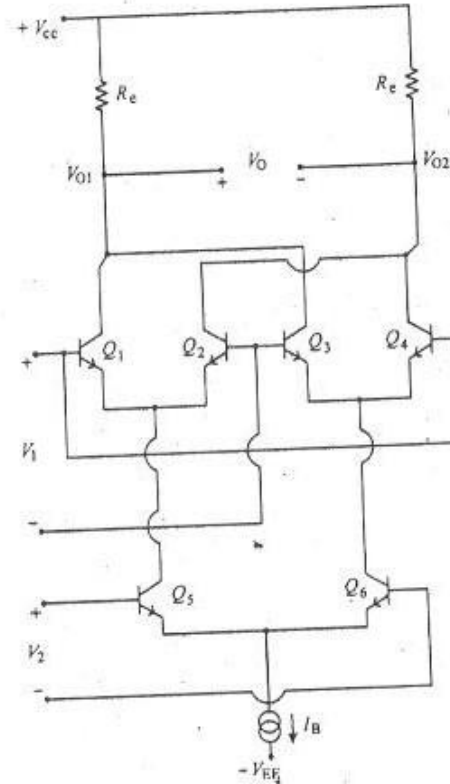

For the circuit shown in the above figure determine by relevant analysis, under what conditions the output voltage is proportional to the multiplication of the two inputs  $V_1$  and  $V_2$ . Derive an expression for  $V_0$  in terms of  $I_B$ ,  $V_1$  and  $V_2$ .

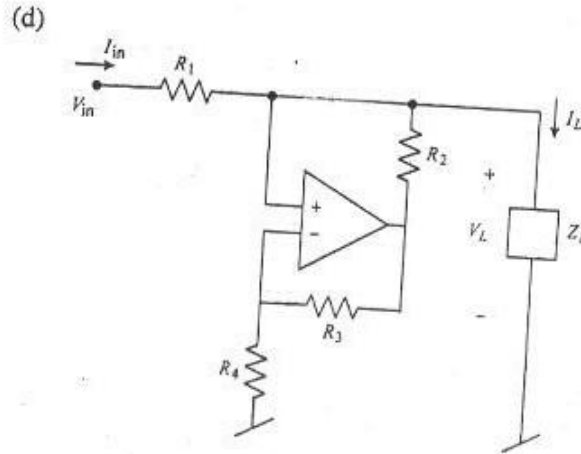

Explain the operation of the circuit shown in the above figure and determine under what condition the output current ( $I_L$ ) can be made independent of load voltage? 10

3. (a) Design a counter that has a repeated sequence of six states as given in the table below :

Count Sequence		
A	B	C
0	0	0
0	0	1
0	1	0
1	0	0
1	0	1
1	1	0

20

A-FRF-M-DSB

8

(Contd.)

- (b) Reduce the following state diagram and also write the reduced state table. 20

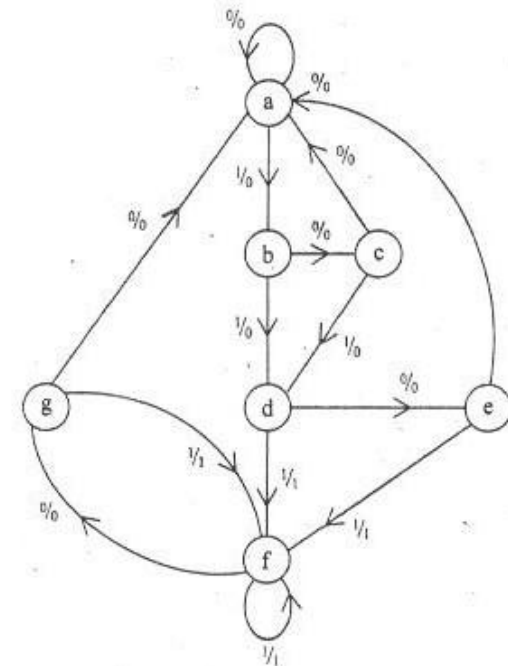

There are infinite number of input sequences that can be considered. Consider the input sequence 01010110100 starting from the initial state 'a'.

9

A-FRF-M-DSB

(Contd.)

4. (a) Consider a feedback system whose open-loop transfer function is given by

$$G(s)H(s) = \frac{K}{s(1+Ts)}, \text{ where } K > 0 \text{ and } T > 0.$$

Using the Nyquist stability criterion, find whether the closed-loop system is stable or not. 20

- (b) Using polar plot method, find the gain margin of a feedback system whose open-loop transfer function is given by

$$G(s)H(s) = \frac{0.75}{s(1+s)(1+0.5s)} \quad 10$$

- (c) Consider a feedback system with characteristic equation

$$1 + \frac{K}{s(s+1)(s+2)} = 0.$$

Compute the angles of the asymptotes of the root-locus branches with the real axis of the  $s$ -plane. Also find the centroid and the breakaway points of the root-locus of the system. Assume that  $K$  varies from 0 to  $\infty$ . 10

5. (a) Assume a Binary symmetric channel with probability of incorrect reception  $(p) = \frac{1}{4}$  and probability of correct reception  $(q) = \frac{3}{4}$ . Let all the transmitted symbols  $\{x_1, x_2\}$  be equally probable i.e.  $p(0) = p(1) = \frac{1}{2}$ . Calculate the improvements in rate of transmission by 2 and 3 repetitions of the input. 10
- (b) Evaluate the radiation or far-field of short Magnetic Dipole and its equivalent small loop. 10

(c)

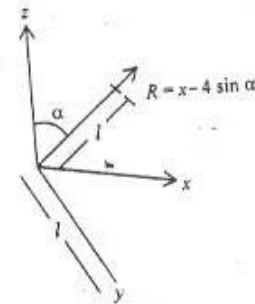

A V-shaped antenna is shown in the above figure. The current distribution on the antenna is given by  $I = I_0 \cos(K_0 u)$  and the length of the antenna is  $l$ . Find the maximum field strength along the  $x$ -axis if  $l = \frac{\lambda}{4}$  and  $\alpha = 45^\circ$ . 10

(d)

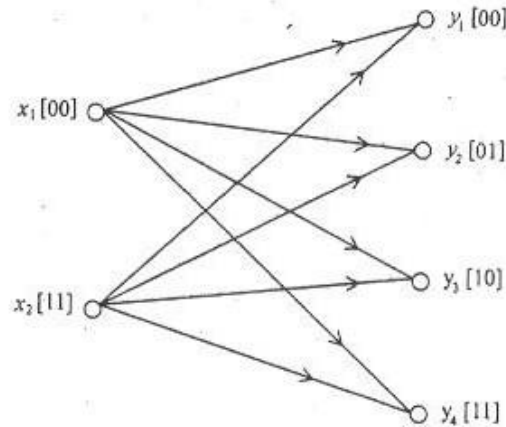

Calculate the rate of joint information transmission for the above channel. Assume  $p(x_1) = p(x_2) = \frac{1}{2}$  where  $[X] = \{x_1, x_2\}$  is the set of input symbols.

Assume  $q \rightarrow$  Probability of correct reception,  
 $p =$  Probability of incorrect reception  
 and

$[Y] = \{y_1, y_2, y_3, y_4\}$  be the set of received symbols. 10

6. (a) Give the small signal equivalent circuit of MESFET (Metal Semiconductor Field Effect Transistor). Identify intrinsic elements and extrinsic elements in the small signal circuit. A certain MESFET has the following parameters :

$R_s$  (source gate resistance) =  $3 \Omega$

$R_i$  (input resistance) =  $2.5 \Omega$

$g_m$  (transconductance) =  $50 \text{ m}\mathcal{U}$

$R_d$  (drain resistance) =  $450 \Omega$

$R_s$  (source resistance) =  $2.5 \Omega$

$C_{gs}$  (gate source capacitance) =  $0.65 \text{ pF}$

Determine

- (i) the cut-off frequency and
- (ii) maximum operating frequency. 4+2+4

(b) Calculate the power gain of a horn antenna of square aperture, have the dimension of each side as  $4\lambda$ .

The power gain of a circular mouth parabolic antenna is 1600 at a wavelength of 10 cm. Calculate the diameter of the mouth and half power beam width of the antenna.

What are the drawbacks of parabolic reflectors ? 4+3+3

- (c) Define critical frequency, skip distance and maximum usable frequency. What are two most important layers of ionosphere for communication? A geostationary communication satellite has an uplink frequency of 6 GHz with antenna elevation of 5. If the transmitter power is 1 kW and the antenna gain of the transmitter and receiver are 60 dB respectively, calculate the received power at the input of the satellite receiver. 6+4

- (d) What is a Bolometer? How many types of Bolometer exist?

Two directional couplers (20 dB) are used in a guide to sample the incident and reflected powers. The outputs of the two couplers are 3 MW and 0.1 MW respectively. What is the value of VSWR in the main waveguide and the value of reflected power? 1+3+6

7. (a) Write a C program for Bubble Sorting a list of 8 numbers given in your program. The exact numbers may be arbitrarily chosen. 10

A-FRF-M-DSB

14

(Contd.)

- (b) Show a complete simple block diagram of a typical computer in as much details as possible, explaining briefly the role of each block particular those of

- (i) Control Unit 10  
(ii) Main Memory. 10

- (c) Explain different types of interrupts available in an 8085 microprocessor in details. 10

- (d) (i) Draw complete block diagram for processor to memory communication. 5

- (ii) Draw complete block diagram for processor to I/O communication. 5

A-FRF-M-DSB

15