

# Super Talent Batches



## MADE EASY

India's Best Institute for IES, GATE & PSUs

*announcing*

### Electronics Engineering

# Super Talent Batches

at **Kalu Sarai** premise of **Delhi**

**1** **st Batch** : Commencing from **Mid May**  
Morning Batch

**2** **nd Batch** : Commencing from **Mid June**  
Evening Batch

#### Eligibility (Any of the following)

- Top 2000 Rank in GATE
- B.Tech from IIT
- B.Tech from Private Engineering college with 70% marks
- Appeared in IES or 3 PSUs Interview
- B.Tech from NIT with 65% marks

#### Benefits

- Better Teaching Environment
- Extra teaching hours
- In-depth coverage of subjects

**Section - I (Technical)**

- Q.1** In the voltage regulator shown in figure op-amp is ideal. The BJT has  $V_{BE} = 0.7\text{ V}$  and  $\beta = 100$  and Zener voltage  $V_z$  is  $4.7\text{ V}$  for a regulated output of  $9\text{ V}$  the value of  $R$  in  $\Omega$  is

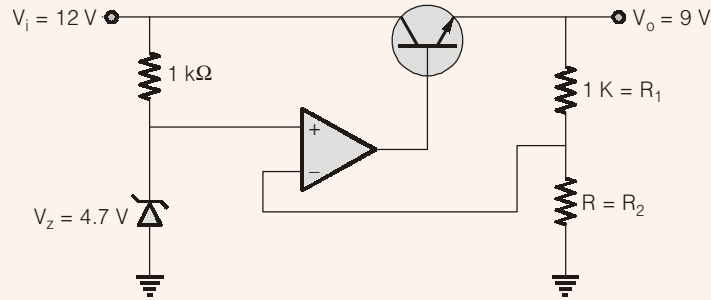

**Solution: (1093.0232)**

Given circuit is a op-amp series regulator

$V_o$  is given by

$$V_o = \left(1 + \frac{R_1}{R_2}\right) V_z$$

$$9\text{ V} = \left(1 + \frac{1\text{ k}\Omega}{R_2}\right) 4.7$$

$$\therefore R_2 = 1093.0232\ \Omega$$

• • • **End of Solution**

- Q.2** A depletion type N-channel MOS is biased in its linear region to use as a voltage controlled resistor. Assume  $V_{th} = 0.5\text{ V}$ ,  $V_{GS} = 20\text{ V}$ ,  $V_{DS} = 5\text{ V}$ ,  $\frac{W}{L} = 100$ ,  $C_{OX} = 10^{-8}\text{ F/m}^2$ ,  $\mu_n = 800\text{ cm}^2/\text{V}\cdot\text{s}$ . Find the resistance of voltage control resistor in  $(\Omega)$ .

**Solution: (641025.641)**

Voltage controlled resistor  $r_{DS}$  is given by

$$r_{DS} = \frac{1}{(\mu_n C_{OX}) \left(\frac{W}{L}\right) (V_{GS} - V_t)}$$

$$r_{DS} = \frac{1}{800 \times 10^{-4} \times 10^{-8} \times 100 \times (20 - 0.5)}$$

$$r_{DS} = 641.02\text{ k}\Omega$$

• • • **End of Solution**

**Q.3** Capacity of binary symmetric channel with cross-over probability 0.5 \_\_\_\_.

**Solution: (0)**

Channel capacity of BSC is

$$C = P \log_2 P + (1 - P) \log_2 (1 - P) + 1$$

$$C = 0.5 \log_2 0.5 + 0.5 \log_2 0.5 + 1$$

$$C = 0$$

It is the case of channel with independent input and output, hence  $C = 0$ .

• • • **End of Solution**

**Q.4** In BJT transistor  $V_{BE} = 0.7 \text{ V}$  and  $V_T = 25 \text{ mV}$  and reverse saturation current is  $10^{-13} \text{ A}$ . Find the transconductance in  $\left(\frac{\text{mA}}{\text{V}}\right)$ .

**Solution: (5785.0282)**

We know that

$$g_m = \frac{I_c}{V_T}$$

where 
$$I_c = I_s e^{\frac{V_{BE}}{V_T}}$$

So, 
$$I_c = 10^{-13} \times e^{\frac{0.7}{0.025}}$$

$$I_c = 144.6257 \text{ mA}$$

Hence, 
$$g_m = \frac{144}{0.025} = 5785.0282 \frac{\text{mA}}{\text{V}}$$

• • • **End of Solution**

**Q.5** Find the RMS value of the given pulse

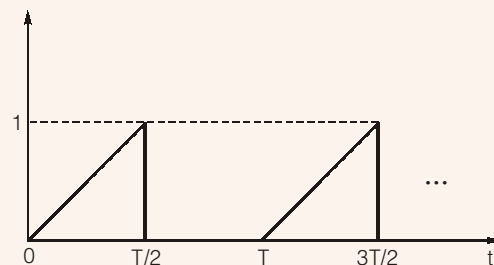

**Solution: (0.4082)**

$$\text{RMS value} = \sqrt{\frac{1}{T} \int_0^T f^2(t) dt}$$

where T is time period

$$= \sqrt{\frac{1}{T} \left[ \int_0^{T/2} \left(\frac{2}{T}t\right)^2 dt + \int_{T/2}^T (0)^2 dt \right]}$$

$$= \sqrt{\frac{1}{T} \left[ \int_0^{T/2} \frac{4}{T^2} t^2 dt \right]}$$

So,  $\text{RMS value} = \sqrt{\frac{1}{6}}$  or 0.408

• • • **End of Solution**

**Q.6** Let  $x(n) = \left(\frac{-1}{9}\right)^n u(n) - \left(\frac{1}{3}\right)^n u(-n-1)$  ROC of z-transform is

(a)  $|Z| < \frac{1}{9}$

(b)  $|Z| < \frac{1}{3}$

(c)  $\frac{1}{3} > |Z| > \frac{1}{9}$

(d) does not exist

**Solution: (c)**

$$x(n) = \underbrace{\left(\frac{-1}{9}\right)^n u(n)}_{\text{Right sided signal}} - \underbrace{\left(\frac{1}{3}\right)^n u(-n-1)}_{\text{Left sided signal}}$$

$\therefore \text{ROC } |Z| > \frac{1}{9}$        $\therefore \text{ROC is } |Z| < \frac{1}{3}$

Hence ROC is  $\frac{1}{3} > |Z| > \frac{1}{9}$

• • • **End of Solution**

**Q.7** The amplifier shown in figure. The BJT parameters are,  $V_{BE} = 0.7 \text{ V}$ ,  $\beta = 200$ ,  $V_T = 250 \text{ mV}$ . Find the gain  $\frac{V_o}{V_i} = \underline{\hspace{2cm}}$ .

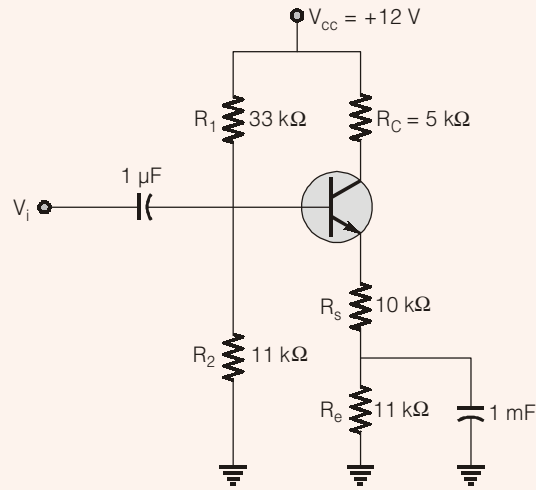

**Solution: (-0.4889)**

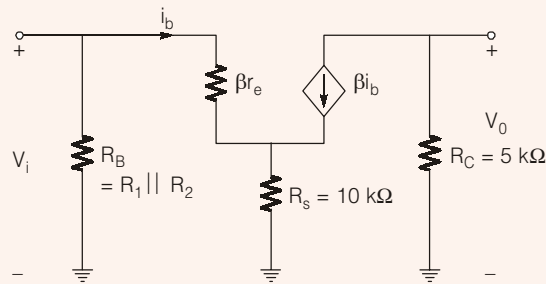

$$V_i = \beta i_b r_e + (i_b + \beta i_b) R_s$$

$$V_i = \beta i_b r_e + i_b (1 + \beta) R_s$$

$$V_i = i_b [\beta r_e + (1 + \beta) R_s] \quad \dots(i)$$

$$V_0 = -R_c \beta i_b \quad \dots(ii)$$

$$\therefore \frac{V_0}{V_i} = \frac{-R_c \times \beta \times i_b}{i_b [\beta r_e + (1 + \beta) R_s]}$$

$$A_V = \frac{-R_c \times \beta}{\beta r_e + (1 + \beta) R_s} \quad \dots(iii)$$

where  $r_e$  is given by

$$r_e = \frac{V_T}{I_E}$$

from dc analysis

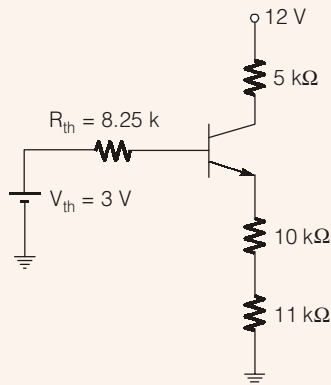

$$R_{th} = 33k \parallel 11k = 8.25k$$

$$V_{th} = \frac{11 \times 12}{44} = 3V$$

$$3 = 8.25k I_B + 21k I_E$$

$$3 = 8.25 \frac{I_E}{1 + \beta} + 21k I_E$$

$$3 = I_E \left[ \frac{8.25}{201} + 21k \right]$$

$$I_E = 0.142 \text{ mA}$$

$$\therefore r_e = \frac{25 \text{ mV}}{0.142 \text{ mA}}$$

$$r_e = 176.0563 \Omega$$

$$\text{So, } A_v = \frac{-5k \times 200}{200 \times 176.0563 + 201 \times 10k}$$

$$= -0.4889$$

● ● ● End of Solution

- Q.8** A transmission line has characteristic impedance is  $50 \Omega$  and length  $l = \lambda/8$ . If load  $Z_L = (R + j30)\Omega$ , then what is the value of R, if input impedance of transmission line is real is \_\_\_\_\_  $\Omega$ .

**Solution: (40)**

$$Z_{in} = Z_o \left\{ \frac{Z_L + jZ_o \tan \beta l}{Z_o + jZ_L \tan \beta l} \right\}$$

Here  $\beta = \frac{2\pi}{\lambda}$  and  $l = \frac{\lambda}{8}$

$\therefore \tan \beta l = \tan \frac{\pi}{4} = 1$

Thus, 
$$Z_{in} = Z_o \left\{ \frac{Z_L + jZ_o}{Z_o + jZ_L} \right\} = 50 \left\{ \frac{R + j30 + j50}{50 + jR - 30} \right\}$$

$$= \frac{50(R + j80)}{(20 + jR)}$$

$\Rightarrow$  
$$= \frac{50(R + j80)}{(20 + jR)}$$

For  $Z_{in}$  to be real

$$Z_{in} = \frac{50(R + j80)(20 - jR)}{(20 + jR)(20 - jR)} = \frac{50(R + j80)(20 - jR)}{(R^2 + 400)}$$

$$= \frac{50(R + j80)}{(20 + jR)}$$

For  $Z_{in}$  to be real

$$Z_i = \frac{50(R + j80)(20 - jR)}{(20 + jR)(20 - jR)} = \frac{50(R + j80)(20 - jR)}{(R^2 + 400)}$$

$\Rightarrow -jR^2 + j1600 = 0$

or  $R = \sqrt{1600} = 40 \Omega$

• • • End of Solution

**Q.9** Which of the following equation is correct?

(a)  $E[x^2] > [E(x)]^2$  (b)  $E[x^2] \geq [E(x)]^2$

(c)  $E[x^2] < [E(x)]^2$  (d)  $E[x^2] \leq [E(x)]^2$

**Solution: (b)**

Variance  $\sigma_x^2 = E(x^2) - [E(x)]^2$

$\therefore \sigma_x^2$  can never be negative.

$\therefore E[x^2] \geq [E(x)]^2$

• • • End of Solution

**Q.10** What is the value of K for which the forward path unity negative feedback transfer function will have both poles at same location.

$$G(s) = \frac{K}{(s+2)(s-1)}$$

**Solution: (2.25)**

Using root locus

Break point

$$1 + \frac{K}{(s+2)(s-1)} = 0$$

or 
$$K = -(s+2)(s-1)$$

$$\frac{dK}{ds} = -2s - 1 = 0$$

or 
$$s = -0.5$$

$\therefore |G(s)|_{s=-0.5} = 1$

$$K = 2.25$$

For both the poles at the same locations.

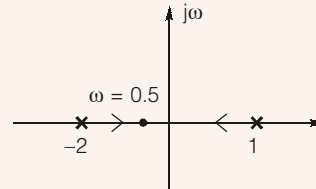

• • • **End of Solution**

**Q.11** For the circuit given below, what will be the largest value of arm when it is converted into delta form.

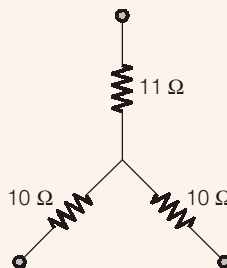

**Solution: (32)**

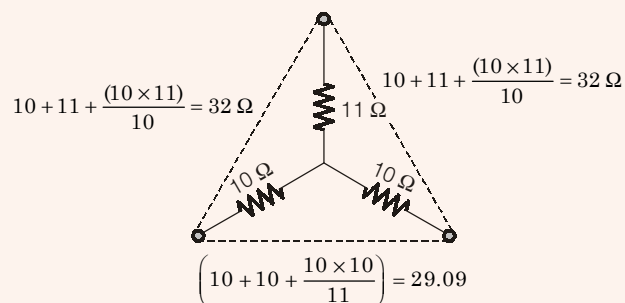

• • • **End of Solution**



**Q.12** Consider the signals:

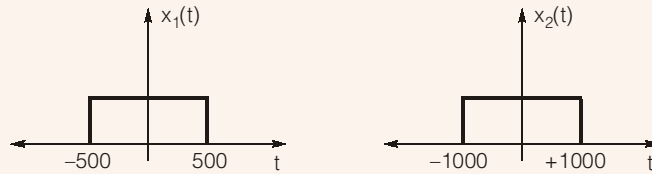

If both the signals are multiplied, then the Nyquist rate is \_\_\_\_\_ Hz.

**Solution: (3000)**

Multiplication in time domain = convolution in frequency domain.

$$x_1(t) \cdot x_2(t) = X_1(j\omega) X_2(j\omega)$$

$$\begin{aligned} \therefore \text{Fundamental frequencies} &= f_1, f_1 \pm f_2, f_1 \pm 2f_2 \dots \\ &= 500, 1500 \dots \end{aligned}$$

$$\text{Nyquist rate} = 2 \times 1500 = 3000 \text{ Hz}$$

• • • End of Solution

**Q.13** When the optical power incident on photo diode is  $10 \mu\text{W}$  and the responsivity  $R = 0.8 \text{ A/W}$  then the photo current generated is \_\_\_\_\_  $\mu\text{A}$ .

**Solution: (8)**

$$\text{Responsivity (R)} = \frac{I_p}{P_o}$$

where

$I_p$  = Photo current

$P_o$  = Incident power

$\therefore$

$$I_p = R \times P_o = 8 \mu\text{A}$$

• • • End of Solution

**Q.14** The value of F is

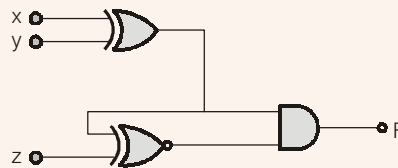

(a)  $X \bar{Y} Z + \bar{X} Y Z$

(b)  $\bar{X} \bar{Y} Z + \bar{X} Y \bar{Z}$

(c)  $\bar{X} \bar{Y} \bar{Z} + X Y Z$

(d)  $X \bar{Y} \bar{Z} + \bar{X} Y \bar{Z}$

**Solution: (a)**

$$\begin{aligned} F &= (X \oplus Y) \odot Z (X \oplus Y) \\ &= [(\bar{X} Y + X \bar{Y}) \odot Z] (\bar{X} Y + X \bar{Y}) \\ &= [(\bar{X} Y + X \bar{Y})' Z' + (\bar{X} Y + X \bar{Y}) Z] (\bar{X} Y + \bar{Y}) \\ &= [(\bar{X} \bar{Y} + XY) \bar{Z} + \bar{Y} Y Z + X \bar{Y} Z] (\bar{X} Y + X \bar{Y}) \\ &= X \bar{Y} Z + \bar{X} Y Z \end{aligned}$$

**Q.15** If  $h(t) = \begin{cases} 3; & 0 < t < 3 \\ 0; & \text{else} \end{cases}$  and a constant input  $x(t) = 5$  is applied then the steady state value of output  $y(t)$  is \_\_\_\_\_.

**Solution: (15)**

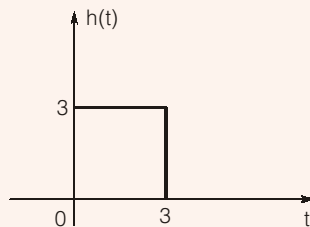

$$h(t) = \begin{cases} 3; & 0 < t < 3 \\ 0; & \text{else when} \end{cases}$$

$\therefore$

$$h(t) = 3[u(t) - u(t - 3)]$$

and

$$x(t) = 5\delta(t)$$

Therefore

$$y(t) = h(t) \otimes x(t)$$

or

$$Y(s) = H(s)X(s)$$

$$= 3 \left( \frac{1}{s} - \frac{e^{-3s}}{s} \right) \times 5 = 15 \left( \frac{1}{s} - \frac{e^{-3s}}{s} \right)$$

$$\text{Steady state value of } Y(s) = \lim_{s \rightarrow 0} sY(s) = 15$$

• • • **End of Solution**

**Q.16** For the given circuit, the value of capacitor is in mF. So that the system will be critically damped is \_\_\_\_\_.

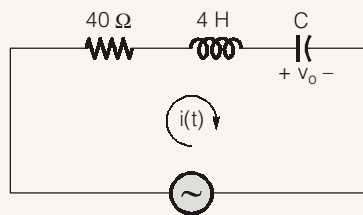

**Solution: (10)**

For critical damping

$$\xi = \frac{1}{2Q} = 1, \quad \text{where } Q \text{ is quality factor.}$$

For series circuit,  $Q = \frac{1}{R} \sqrt{\frac{L}{C}}$

$\therefore \frac{1}{\frac{2}{R} \sqrt{\frac{L}{C}}} = 1$

or  $C = \left(\frac{2}{R}\right)^2 \times L = \left(\frac{2}{40}\right)^2 \times 4 = 10 \text{ mF}$

• • • End of Solution

**Q.17** In the figure there is a low pass filter with a cut-off frequency of 5 kHz. The value of  $R_2$  in ( $k\Omega$ ) \_\_\_\_\_.

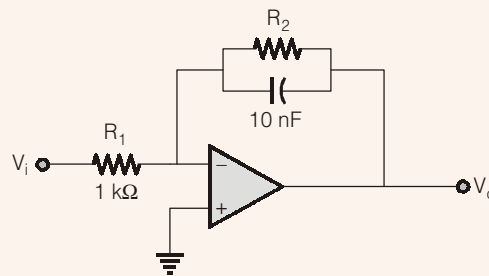

**Solution: (3.184)**

$$= \frac{0 - V_o}{Z_2} + \frac{0 - V_i}{Z_1} = 0$$

where  $Z_2 = R_2 \parallel 10 \text{ nF}$   
 $Z_1 = R_1 = 1 \text{ k}\Omega$

or  $\frac{V_o}{V_i} = -\frac{z_2}{z_1} = -\frac{R_2 \parallel \frac{1}{Cs}}{R_1} = \frac{R_2}{R_1(R_2Cs + 1)}$

cut-off frequency

$$|1 + R_2 Cs| = 0$$

or  $R_2 Cs = 1$

or  $R_2 = \frac{1}{Cs} = \frac{1}{2\pi fC} = 3184.7 \text{ or } 3.18 \text{ k}\Omega$

• • • End of Solution

**Q.18** In the figure shown below has a PN diode with a cut-off voltage of 0.7 V a Schottky diode with a cut-off voltage of 0.3 V. If ON indicates conducting state and off indicates non conducting state then

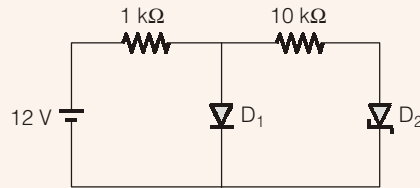

- (a)  $D_1$  is ON and  $D_2$  is ON                      (b)  $D_1$  is OFF and  $D_2$  is ON  
(c)  $D_1$  is OFF and  $D_2$  is OFF                      (d)  $D_1$  is ON and  $D_2$  is OFF

**Solution: (a)**

• • • **End of Solution**

**Q.19** Given  $G(s) = \frac{10}{(s+1)(s+0.1)(s+10)}$

The value of PM is \_\_\_\_\_.

**Solution: (55.57)**

Finding  $\omega_{gc} = \frac{10}{\sqrt{\omega^2 + 1} \sqrt{\omega^2 + 0.01} \sqrt{\omega^2 + 100}} = 1$   
 $= \frac{100}{(\omega^2 + 1)(\omega^2 + 0.01)(\omega^2 + 100)} = 1$

$100 = (\omega^2 + 1) [\omega^2 + 0.01\omega^2 + 100\omega^2 + 1]$   
 $= \omega^6 + 100.01 \omega^4 + 101.01 \omega^2 - 99 = 0$

or  $\omega^2 = 0.6, -1.6, -99.99.989$

$\therefore \omega_{gc} = \sqrt{0.6} = 0.774 \text{ rad/sec}$

$PM = 180^\circ + \angle G(\omega) \Big|_{\omega=\omega_{gc}}$   
 $= 180^\circ + \tan^{-1} \left( \frac{\omega_{gc}}{1} \right) - \tan^{-1} \left( \frac{\omega_{gc}}{0.1} \right) - \tan^{-1} \left( \frac{\omega_{gc}}{10} \right)$   
 $= 180^\circ - 37.74^\circ - 82.638^\circ - 4.426^\circ$   
 $= 55.57^\circ$

• • • **End of Solution**

**Q.20** Open loop transfer function of unity feedback system is  $G(s)$  and its block diagram and polar plot given

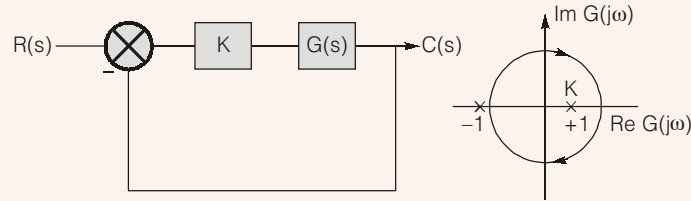

Then find the correct statement

- (a)  $G(s)$  is all pass filter
- (b)  $G(s)$  is stable and non minimum phase system
- (c) Closed loop system unstable for high value of 'k'
- (d) None of these

**Solution: (c)**

- For all pass system the pole zero pair must be symmetrical about imaginary axis with zero on the RHS and pole on the LHS of s-plane.
- This is not minimum phase system.
- Encirclement to the critical point  $(-1, 0) = N = 0$

Open loop pole at RHS =  $P = 1$

$\therefore$

$$N = P - Z$$

$$Z = 1 \quad (\text{Close loop pole at RHS of s-plane})$$

thus, the given system is unstable system.

• • • **End of Solution**

**Q.21** A system having differential equation  $\dot{y}(t) + 5y(t) = u(t)$  and  $y(0) = 1$ . Then output response of the system is

- (a)  $0.2 + 0.8e^{-5t}$
- (b)  $0.8 - 0.2e^{-5t}$
- (c)  $0.2 - 0.8e^{-5t}$
- (d)  $0.8 + 0.2e^{-5t}$

**Solution: (a)**

$$\frac{dy}{dt} + 5y(t) = u(t)$$

$$y(0) = 1$$

$$\Rightarrow sY(s) - y(0) + 5Y(s) = \frac{1}{s}$$

$$\Rightarrow sY(s) - 1 + 5Y(s) = \frac{1}{s}$$

$$Y(s) [s + 5] = \left( \frac{1}{s} + 1 \right)$$

$$Y(s) = \frac{(s+1)}{s(s+5)} = \frac{A}{s} + \frac{B}{(s+5)}$$

$$Y(s) = \frac{1}{5s} + \frac{4}{s(s+5)}$$

$$\therefore y(t) = \frac{1}{5} u(t) + \frac{4}{5} e^{-5t} u(t)$$

$$y(t) = (0.2 + 0.8 e^{-5t})$$

● ● ● **End of Solution**

- Q.22** Find the fundamental period of the signal  $x[n] = \sin[\pi^2 n]$
- (a) Periodic with  $\pi/2$  (b) Periodic with  $\pi$   
(c) Periodic with  $2/\pi$  (d) Non periodic

**Solution: (d)**

Time period of a discrete signal

$$\frac{\omega_0}{2\pi} = \frac{K}{N}$$

$$\text{or } N = \frac{2\pi}{\omega_0} = \frac{2\pi}{\pi^2} = \frac{2}{\pi}$$

$\therefore N$  is an irrational number hence the given signal is not periodic.

● ● ● **End of Solution**

- Q.23** Ideal current buffer is having
- (a) Low input impedance and high output impedance  
(b) High input impedance and high output impedance  
(c) High input impedance and low output impedance  
(d) low input impedance and low output impedance

**Solution: (a)**

● ● ● **End of Solution**

- Q.24** If the open loop transfer function  $G(s) = \frac{1}{(s+1)(s+2)}$

then, what factor should be multiplied in  $G(s)$ , so that the settling time for 2% is less than 2 sec.

- (a)  $4(s+4)$  (b)  $\frac{1}{s+2}$   
(c)  $\frac{1}{s}(1+0.2s)$  (d) None of these

**Solution: (a)**

Cross checking with the options

Let the factor is  $4(s + 4)$

then, 
$$G(s) = \frac{4(s + 4)}{(s + 1)(s + 2)}$$

$$\therefore T(s) = \frac{G(s)}{1 + G(s)H(s)} = \frac{4(s + 4)}{1 + \frac{4(s + 4)}{(s + 1)(s + 2)}}$$

or 
$$T(s) = \frac{4(s + 4)(s + 1)(s + 2)}{(s + 1)(s + 2) + 4(s + 4)}$$

Comparing with standard equation

C.E. =  $s^2 + 7s + 18 = 0$

$$\therefore \xi \omega_n = 3.5$$

$$\tau_{\text{sett}} = \frac{2}{\xi \omega_n} = 0.571 \text{ sec}$$

The option (b) results in repeated poles in the equation and option (c) results in cubic equation in the given transfer function.

Hence option (a) is correct answer.

● ● ● End of Solution

**Q.25** Minimized expression for  $(x + y)(x + \bar{y}) + \overline{(x\bar{y})} + \bar{x}$  is

- (a) x
- (b) y
- (c) xy
- (d) x + y

**Solution: (a)**

$$\begin{aligned} f &= x + xy + x\bar{y} + \overline{(x\bar{y})} + \bar{x} \\ &= x + xy + x\bar{y} + (\bar{x} + y) + \bar{x} \\ &= x(1 + y + \bar{y}) = x \end{aligned}$$

● ● ● End of Solution

**Q.26**

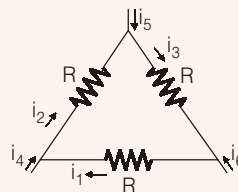

Where  $R = 1\Omega$ ,  $i_1 = 2A$ ,  $i_4 = -1A$ ,  $i_5 = -4A$ . Then which of the following is correct

- (a)  $i_6 = 5A$
- (b)  $i_3 = -4A$
- (c) Given data sufficient to tell these currents are not possible
- (d) Data is non sufficient to find  $i_2$ ,  $i_3$  and  $i_6$

**Solution: (a)**

Using KVL at all the three nodes,

$$\Rightarrow i_4 + i_1 + i_2 = 0$$

$$i_6 + i_3 - i_1 = 0$$

$$i_5 + i_2 - i_3 = 0$$

Solving these equations we get

$$i_6 = 5 \text{ A}$$

• • • **End of Solution**

**Q.27** A CDMA scheme having number of chips  $N = 8$  chips, then the number of users of orthogonal sequence is \_\_\_\_\_.

**Solution: (16)**

• • • **End of Solution**

**Q.28** If  $Q(\sqrt{\gamma})$  is the probability of error for BPSK AWGN channel. Now two independent identical BPSK AWGN channels are connected as shown in below figure

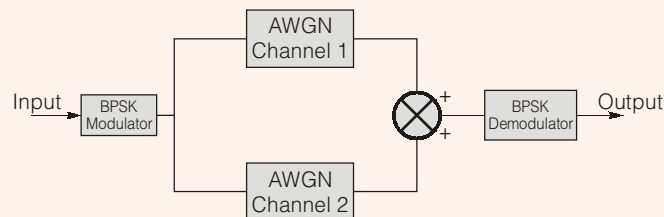

For this the probability of error is  $Q(b\sqrt{\gamma})$  then the value of 'b' \_\_\_\_\_

**Solution: (0.707)**

• • • **End of Solution**

**Q.29**  $X_1, X_2, X_3$  are three independent random variables having uniform distribution between  $[0, 1]$  then  $P[x_1 + x_2 \leq x_3]$  to be greatest value is \_\_\_\_\_.

**Solution: (0.5)**

• • • **End of Solution**

**Q.30** A system having state model

$$\begin{bmatrix} \dot{x}_1 \\ \dot{x}_2 \\ \dot{x}_3 \end{bmatrix} = \begin{bmatrix} -1 & 1 & 0 \\ 0 & 1 & 0 \\ 1 & 0 & 2 \end{bmatrix} \begin{bmatrix} x_1 \\ x_2 \\ x_3 \end{bmatrix} + \begin{bmatrix} 0 \\ 4 \\ 0 \end{bmatrix} u$$

$$y = [1 \ 1 \ 1] \begin{bmatrix} x_1 \\ x_2 \\ x_3 \end{bmatrix} \text{ then the system is}$$

- (a) Controllable and observable                      (b) Uncontrollable and observable  
(c) Uncontrollable and unobservable                (d) Controllable and unobservable



**Solution: (a)**

Check for controllability

$$Q_c = [B : AB : A^2B \dots]$$

$$Q_c = \begin{bmatrix} 0 & 4 & 0 \\ 4 & 4 & 4 \\ 0 & 0 & 4 \end{bmatrix}$$

$$\therefore |Q_c| = -4(16 - 0) \neq 0 \quad \therefore \text{controllable}$$

check for observability

$$Q_0 = [C^T : A^T C^T : (A^T)^2 C^T \dots]$$

$$Q_0 = \begin{bmatrix} 1 & 0 & 2 \\ 1 & 2 & 2 \\ 1 & 2 & 4 \end{bmatrix}$$

$$\therefore |Q_0| = -4 \neq 0 \quad \therefore \text{observable}$$

• • • End of Solution

**Q.31** The value of  $\oint_c \frac{z^2 - z + 4j}{z + 2j} dz$  where the curve  $c$  is  $|z| = 3$

- (a)  $4\pi(3 + 2j)$  (b)  $-4\pi(3 + 2j)$   
(c)  $4\pi(3 - 2j)$  (d)  $4\pi(-3 + 2j)$

**Solution: (b)**

$$\begin{aligned} \text{Residue} &= 2\pi j \{ \text{Re } f(z) \}_{z=-j2} \\ &= 2\pi j \{ (-2)^2 - (-j2) + 4j \} \\ &= -4\pi(3 + 2j) \end{aligned}$$

or

• • • End of Solution

**Q.32** A 230 V source is connected to two loads in parallel. Load 1 consumes 10 kW power with 0.8 leading power factor, load 2 consumes 10 kVA with 0.8 lagging power factor then total complex power supplied by the source is

- (a)  $18 + 1.5j$  (b)  $18 - 1.5j$   
(c)  $18 + 20j$  (d)  $18 - 20j$

**Solution: (b)**

$$\begin{aligned} S &= S_1 + S_2 \\ &= \frac{10}{0.8} \angle -\cos^{-1} 0.8 + 10 \angle \cos^{-1} 0.8 \\ &= 18 - 1.5j \end{aligned}$$

• • • End of Solution

**Q.33** Volume bounded by the surface  $z(x, y) = x + y$  is the  $xy$ -plane. Where  $0 \leq y \leq x$ ,  $0 \leq x \leq 12$  \_\_\_\_\_

**Solution: (864)**

• • • **End of Solution**

**Q.34** Taylor's series expansion of  $(3 \sin x + 2 \cos x)$

- (a)  $2 + 3x - x^2 - \frac{x^3}{2}$  (b)  $2 - 3x + x^2 - \frac{x^3}{2}$   
(c)  $2 + 3x - x^2 + \frac{x^3}{2}$  (d)  $-2 + 3x + x^2 + \frac{x^3}{2}$

**Solution: (a)**

• • • **End of Solution**

**Q.35** If  $x(t) = A \sin(2\pi t + \phi)$ ,  $\phi$  is phase then the autocorrelation function  $E[x(t_1) \cdot x(t_2)]$  is \_\_\_\_\_.

- (a)  $A^2 \cos[2\pi(t_1 + t_2)]$  (b)  $\frac{A^2}{2} \sin[2\pi(t_1 - t_2)]$   
(c)  $A^2 \cos[2\pi(t_1 - t_2)]$  (d)  $\frac{A^2}{2} \sin[2\pi(t_1 + t_2)]$

**Solution: (c)**

$$\begin{aligned} E[x(t_1) \times x(t_2)] &= E[A \sin(2\pi t_1 + \phi)] \times A \sin(2\pi t_2 + \phi) \\ &= \frac{A^2}{2} E[\cos[2\pi(t_1 - t_2)] - \cos[2\pi(t_1 + t_2 + 2\phi)]] \\ &= \frac{A^2}{2} \cos[2\pi(t_1 - t_2)] \end{aligned}$$

• • • **End of Solution**

**Q.36** The following Boolean expression is  $f(w, x, y, z) = \bar{w}\bar{x}\bar{z} + w\bar{x}\bar{z} + xz + xy + \bar{w}y + wy$ . Then all the essential prime implicants of the expression

- (a)  $y, \bar{w}\bar{x}\bar{z}, xy$  (b)  $xz, wy, w\bar{x}\bar{z}$   
(c)  $y, xz, xy$  (d)  $y, \bar{x}\bar{z}, xz$

**Solution: (d)**

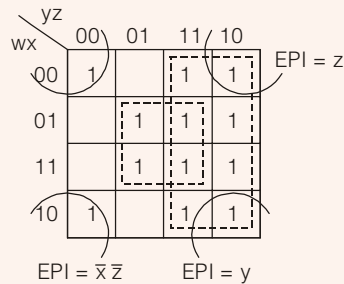

• • • End of Solution

**Q.37** Let  $M, N$  are two matrices of same order and  $C$  is a scalar. Which of the following is not always true

- (a)  $(M^T)^T = M$
- (b)  $(CM)^T = C[M]^T$
- (c)  $(M + N)^T = M^T + N^T$
- (d)  $MN = NM$

**Solution: (d)**

• • • End of Solution

**Q.38** In the given circuit, if  $A$  is connected to  $Q_1$ , the operation of the circuit is according to the state diagram. If XOR is replaced with XNOR, then to get the same operation of the circuit which of the following changes has to be done

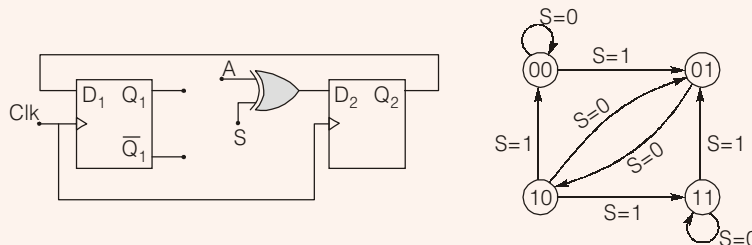

- (a)  $A$  should be connected to  $\bar{Q}_1$
- (b)  $A$  should be connected to  $Q_2$
- (c)  $A$  should be connected of  $Q_1$  and  $S$  is replaced  $\bar{S}$  to  $\bar{Q}_1$
- (d)  $A$  should be connected to  $\bar{Q}_1$  by  $S$  is replaced by  $\bar{S}$

**Solution: (a)**

$D_2 = A \oplus S$

$D_2 = Q_1 \oplus S$

But,

$D_2 = A \odot S$

if

$A = \bar{Q}_1$

then

$D_2 = \bar{Q}_1 \odot S$

$= Q_1 \oplus S$

Then operation does not change.

• • • End of Solution

- Q.39** For parallel transmission line, let 'v' be the speed of propagation and 'z' be the characteristic impedance neglecting fringing effect, a reduction of spacing between the plates by factor of two result is
- Halving 'v' and no change in 'z'
  - No change in 'v' and halving of 'z'
  - No change in 'v' and 'z' both
  - Both 'v' and 'z' half

**Solution: (b)**

● ● ● End of Solution

- Q.40** For the given circuit the output voltage  $V_0$  is

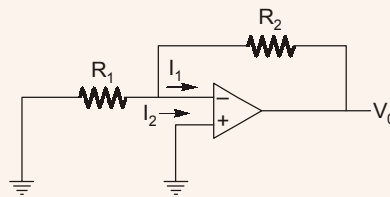

- $-I_1 (R_1 + R_2)$
- $I_2 R_1$
- $I_1 R_2$
- $-I_2 (R_1 + R_2)$

**Solution: (c)**

● ● ● End of Solution

- Q.41** Find the voltage observed at P, Q and R for NMOS transistor and threshold voltage is 1 V

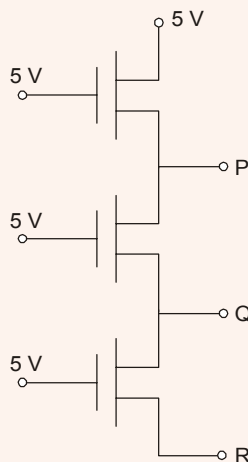

- 5 V, 4 V, 3 V
- 5 V, 5 V, 5 V
- 4 V, 4 V, 4 V
- 8 V, 4 V, 5 V

**Solution: (c)**

● ● ● End of Solution

**Q.42** A charge of 1 C is placed near a good conducting plane at a distance of a meter. What is the value of force F between them?

- (a)  $\frac{1}{4\pi\epsilon_0 d^2}$  (b)  $\frac{1}{8\pi\epsilon_0 d^2}$   
(c)  $\frac{1}{16\pi\epsilon_0 d^2}$  (d) None of these

**Solution: (c)**

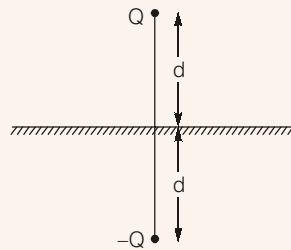

$$F = \frac{Q_1 Q_2}{4\pi\epsilon_0 R^2} = \frac{1 \cdot 1}{4\pi\epsilon_0 (2d)^2} = \frac{1}{16\pi\epsilon_0 d^2}$$

• • • **End of Solution**

**Q.43** The input frequency for the given counters 1 MHz, the output frequency observes at  $Q_4$  is \_\_\_\_\_

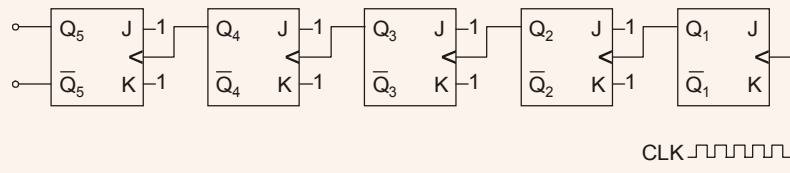

**Solution: (62.5)**

$$f_{Q_4} = \frac{1 \text{ MHz}}{16}$$

$$f_{Q_4} = 62.5 \text{ kHz}$$

• • • **End of Solution**

**Q.44** For the circuit given, if the clock frequency is 1 kHz, then the frequency of output at  $Q_3$  is Hz \_\_\_\_\_.

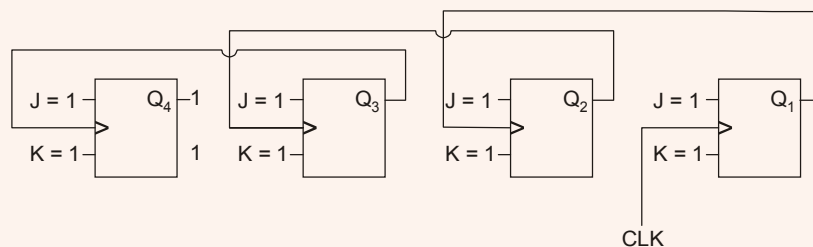

**Solution: (125)**

$$f_{\text{CLK}} = 1 \text{ kHz}$$
$$f_{Q_3} = \frac{f_{\text{CLK}}}{8} = \frac{1 \text{ kHz}}{8} = 125 \text{ Hz}$$

• • • **End of Solution**

### Section - II (Non-Technical)

**Q.45** 12, 35, 81, 173, 357, \_\_\_?\_\_\_.

**Solution: (725)**

$$12 \times 2 + 11 = 35$$
$$35 \times 2 + 11 = 81$$
$$81 \times 2 + 11 = 173$$
$$173 \times 2 + 11 = 357$$
$$357 \times 2 + 11 = 725$$

• • • **End of Solution**

**Q.46** In housing society, half of familiars have a single child per family, while the remaining half have two children per family. The probability that a child picked at random has a sibling is \_\_\_\_\_.

**Solution: (0.6667)**

• • • **End of Solution**

**Q.47** 280 m long train travelling with a uniform speed crosses a platform in 60 sec. and crosses a person standing on the platform in 20 sec. Then find the length of the platform.

**Solution: (560)**

$$\text{Platform length} = x$$
$$\text{Train length} = 280 \text{ m}$$
$$\therefore \frac{x + 280}{60} = \frac{280}{20}$$
$$\text{or } x = 560 \text{ m}$$

• • • **End of Solution**

**Q.48** (i) All the women are entrepreneur.  
(ii) Source of the women are doctors.  
Then by using above statements, which of the following statement is inferred?  
(a) All the doctors are entrepreneurs  
(b) Some doctor are entrepreneurs  
(c) All the entrepreneurs are doctors  
(d) Some entrepreneurs are doctors

**Solution: (d)**

• • • **End of Solution**

- Q.49** A flight \_\_\_\_\_ as soon as it's report was filed  
 (a) is take-off (b) was take-off  
 (c) will take-off (d) has been taken-off

**Solution: (d)**

● ● ● **End of Solution**

- Q.50** In a chart given below, the imports and exports of a product is million dollers are given according to the year basis. In which, deficit is defined as excess of imports over exports. Then find the year in which deficits is equal to  $1/5^{\text{th}}$  of the exports.

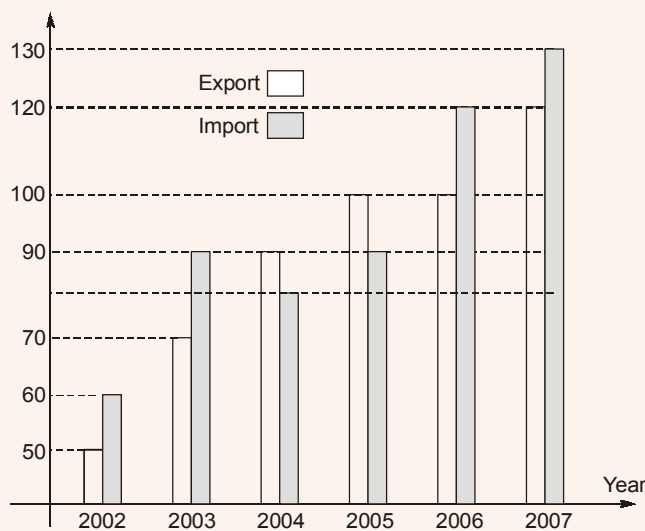

- (a) 2004 (b) 2005  
 (c) 2006 (d) 2007

**Solution: (c)**

● ● ● **End of Solution**

- Q.51** A person having three coins, first coin have both sides head, second coin and third coin having one head and one tail. If one coin is picked up randomly and tossed then the probability that it shows head having tail is  
 (a)  $1/3$  (b)  $2/3$   
 (c)  $1/4$  (d)  $1/2$

**Solution: (a)**

● ● ● **End of Solution**