

TYPICAL QUESTIONS & ANSWERS

PART - I

OBJECTIVE TYPE QUESTIONS

Each Question carries 2 marks.

Choose correct or the best alternative in the following:

- Q.1** The “Superposition theorem” is essentially based on the concept of
(A) duality. (B) linearity.
(C) reciprocity. (D) non-linearity.

Ans: B

- Q.2** Cells are connected in parallel in order to
(A) increase the voltage available. (B) reduce cost of wiring.
(C) increase the current available. (D) reduce the time required to fully charge them after use.

Ans: C

- Q.3** The power factor of a purely resistive circuit is
(A) zero. (B) unity.
(C) lagging. (D) leading.

Ans: B

- Q.4** The power taken by a 3-phase load is given by the expression
(A) $3 V_L I_L \cos \phi$. (B) $\sqrt{3} V_L I_L \cos \phi$.
(C) $3 V_L I_L \sin \phi$. (D) $\sqrt{3} V_L I_L \sin \phi$.

Ans: B

- Q.5** Which of the following generating stations has the minimum running cost?
(A) hydro-electric station. (B) nuclear power station.
(C) thermal power station. (D) diesel power plant.

Ans: A

- Q.6** Which of the following motors has a high starting torque?
(A) ac series motor. (B) dc series motor.
(C) induction motor. (D) synchronous motor.

DE05
DE06

ELECTRICAL ENGINEERING
BASIC ELECTRONICS

Ans: B

- Q.7** A step-up transformer increases
 (A) voltage. (B) current.
 (C) power. (D) frequency.

Ans: A

- Q.8** The effect of increasing the length of the air gap in an induction motor will be to increase
 (A) power factor. (B) speed.
 (C) magnetising current. (D) air-gap flux.

Ans: C

- Q.9** The combined resistance of two equal resistors connected in parallel is equal to
 (A) One half the resistance of one resistor.
 (B) Twice the resistance of one resistor.
 (C) Four times the resistance of one resistor.
 (D) One fourth the resistance of one resistor.

Ans: A

- Q.10** Superposition theorem can be applicable only to circuits having _____ elements.
 (A) Non- linear (B) Passive
 (C) Resistive (D) Linear bilateral

Ans: D

- Q.11** The Q- factor of a coil is given by
 (A) Its power factor $\cos \phi$.
 (B) Ratio of max. energy stored & energy dissipated per cycle..
 (C) Reciprocal of its power factor.
 (D) Ratio R/Z .

Ans: C

- Q.12** Voltage equation of a dc motor is
 (A) $V = E_b + I_a R_a$. (B) $E_b = V + I_a R_a$.
 (C) $V = E_b / I_a R_a$. (D) $V = E_b + I_a^2 R_a$.

Ans: A

- Q.13** The efficiency of a transformer is maximum when
 (A) It runs at half full load. (B) It runs at full load.
 (C) Its Cu loss equals iron loss. (D) It runs overload.

Ans: C

DE05
DE06

ELECTRICAL ENGINEERING
BASIC ELECTRONICS

- Q.14** The crawling in an induction motor is caused by
(A) Improper design of the machine (B) Low voltage supply.
(C) High loads. (D) Harmonics developed in the motor.

Ans: D

- Q.15** The starting winding of a single-phase motor is placed in
(A) Rotor. (B) Stator.
(C) Armature. (D) Field.

Ans: B

- Q.16** Reduction in the capacitance of a capacitor- start motor results in reduced
(A) Noise. (B) Speed.
(C) Starting torque. (D) Armature reaction.

Ans: C

- Q.17** In an ac circuit, the ratio of kW / kVA represents
(A) Power factor. (B) Load factor.
(C) Form factor. (D) Diversity factor.

Ans: A

- Q.18** The unit of inductance is
(A) Ohm. (B) Mho.
(C) Farad. (D) Henry.

Ans: D

- Q.19** Thevenin's equivalent circuit consists of _____.
(A) Series combination of R_{Th} , E_{Th} and R_L .
(B) Series combination of R_{Th} , E_{Th} .
(C) Parallel combination of R_{Th} , E_{Th} .
(D) Parallel combination of R_{Th} , E_{Th} and R_L .

Ans: B

- Q.20** In an R – L –C circuit, the phase of the current with respect to the circuit voltage will be _____.
(A) Leading. (B) Same.
(C) Lagging. (D) Depends upon the value of L and C.

Ans: D

DE05
DE06

ELECTRICAL ENGINEERING
BASIC ELECTRONICS

- Q.21 The frequency of DC supply is_____.
- (A) Zero. (B) $16 \frac{2}{3}$ Hz.
(C) 50 Hz. (D) 100 Hz.

Ans: A

- Q.22 Load factor is defined as the ratio of _____.
- (A) Average Demand / Max. Demand.
(B) Max. Demand / Average Demand.
(C) Average Demand / Connected load.
(D) Connected load / Max. Demand.

Ans: A

- Q.23 Static Capacitors are used for_____.
- (A) Power improvement. (B) Current improvement.
(C) Voltage improvement. (D) Power factor improvement.

Ans: D

- Q.24 The speed of an induction motor_____.
- (A) Decreases too much with the increase of load.
(B) Increases with the increase of load.
(C) Decreases slightly with the increase of load.
(D) Remains constant with the increase of load.

Ans: C

- Q.25 Centrifugal switch is provided for disconnecting the auxiliary winding in a_____.
- (A) Capacitor- start motor. (B) Capacitor run motor.
(C) Reluctance motor. (D) Hysteresis motor.

Ans: A

- Q.26 Rotating magnetic field is produced in a _____.
- (A) Single- phase induction motor. (B) Three- phase induction motor.
(C) DC series motor. (D) AC series motor.

Ans: B

- Q.27 The frequency of the secondary voltage of a transformer will be_____.
- (A) Less than the frequency of the primary voltage.
(B) Equal to the primary voltage.
(C) Greater than the frequency of the primary voltage.
(D) Very much greater than the frequency of the primary voltage.

Ans: B

DE05
DE06

ELECTRICAL ENGINEERING
BASIC ELECTRONICS

- Q.28** The demand factor for the electrical system is the ratio of
- (A) Maximum demand to connected load
 - (B) Maximum demand to average load
 - (C) Average power to maximum power
 - (D) Relative power to total power

Ans: A

- Q.29** When a low resistance is connected in parallel with a high resistance, the combined resistance is
- (A) Always more than the high resistance.
 - (B) Always less than the low resistance.
 - (C) Always between the high resistance & low resistance.
 - (D) Either lower or higher than low resistance depending on the value of high resistance.

Ans: B

- Q.30** Q factor of an inductive coil is given by
- (A) R/Z
 - (B) $2\pi f r/R$
 - (C) $2\pi f L/R$
 - (D) $\ell r/\ell$

Ans: B

- Q.31** The r.m.s. value of sinusoidal 100 V peak to peak is _____ volt.
- (A) $100/\sqrt{2}$
 - (B) $50/\sqrt{2}$
 - (C) 50
 - (D) 100

Ans: B

- Q.32** If the readings of the two wattmeters in the 2-wattmeter method of power measurement are 4.5 kW and 3.5 kW respectively and the latter reading has been obtained after reversing the current coil of the wattmeter. What will be the total power in kW?
- (A) 1
 - (B) 3.5
 - (C) 4.5
 - (D) 8

Ans: A

- Q.33** A DC series motor is best suited for driving
- (A) Lathes.
 - (B) Cranes and hoists.
 - (C) Shears and punches.
 - (D) Machine tools.

Ans: B

- Q.34** Transformer cores are built up from laminations rather than from solid metal so that

DE05
DE06

ELECTRICAL ENGINEERING
BASIC ELECTRONICS

- (A) Oil penetrates the core more easily.
- (B) Eddy current loss is reduced.
- (C) Less lamination is required for the windings.
- (D) Turn ratio is higher than voltage ratio.

Ans: B

- Q.35** In a DC series motor increase in load current results in
- (A) Decrease in speed
 - (B) Increase in speed
 - (C) Better commutation
 - (D) Increase in the back emf.

Ans: A

- Q.36** The starting torque of a 1-phase induction motor is
- (A) High.
 - (B) Moderate.
 - (C) Low.
 - (D) Zero.

Ans: D

- Q.37** An electric motor in which rotor and stator fields rotate simultaneously is called a _____ motor.
- (A) DC
 - (B) Induction
 - (C) Synchronous
 - (D) Universal

Ans: C

- Q.38** In India, electrical power is transmitted by
- (A) 1 – phase a.c. system.
 - (B) 3-wire d.c. system.
 - (C) 3-phase 3-wire a.c. system.
 - (D) 2-wire d.c. system.

Ans: C

- Q.39** In ac circuit the product of voltage and current is known as
- (A) Power.
 - (B) Real power.
 - (C) Resistive power.
 - (D) Apparent power.

Ans: D

- Q.40** A network that does not have either voltage or current sources is called
- (A) Active network.
 - (B) Passive network.
 - (C) Resistive network.
 - (D) Dummy network.

Ans: B

DE05
DE06

ELECTRICAL ENGINEERING
BASIC ELECTRONICS

- Q.41** The Power- factor at resonance in R-L-C circuit is
(A) Zero. (B) Unity.
(C) 0.5 lagging. (D) 0.5 leading.

Ans: B

- Q.42** In an 8 – pole wave connected motor armature, the number of parallel paths are
(A) 8 (B) 4
(C) 2 (D) 1

Ans: C

- Q.43** Transformer core is laminated to
(A) Reduce the copper losses. (B) Reduce the core losses.
(C) Reduce the eddy current losses. (D) None of these.

Ans: C

- Q.44** The relation between frequency, speed and number of poles is given by
(A) $N_s = 120 \times f/p$. (B) $f = 120 \times N_s/p$.
(C) $N_s = 120 \times p/f$. (D) $N_s = f \times p/120$.

Ans: A

- Q.45** Star – delta starter of an induction motor
(A) Inserts resistance in rotor circuit.
(B) Inserts resistance in stator circuit.
(C) Applies reduced voltage to rotor.
(D) Applies reduced voltage to stator.

Ans: D

- Q.46** Stator core of an induction motor is made of
(A) Laminated cast iron. (B) Mild steel.
(C) Silicon steel stampings. (D) Soft wood.

Ans: C

- Q.47** Watt hour is the unit of
(A) Electric power. (B) Electric capacity.
(C) Electric energy. (D) Electric charge.

Ans: C

- Q.48** A battery is a source of
(A) DC voltage. (B) 1 ϕ AC voltage.
(C) 3 ϕ AC voltage. (D) AC or DC voltage.

DE05
DE06

ELECTRICAL ENGINEERING
BASIC ELECTRONICS

Ans: A

- Q.49** Which DC motors has approximately constant speed?
(A) Series motor. (B) Shunt motor
(C) Cumulatively compound motor (D) All of the above.

Ans: B

- Q.50** Which of the following bulbs will have the least resistance?
(A) 220V, 60W (B) 220 V, 100 W
(C) 115 V, 60 W (D) 115V, 100 W

Ans: D

- Q.51** Resistance of a wire is r ohms. The wire is stretched to double its length, then its resistance in ohms is
(A) $r/2$ (B) $4r$
(C) $2r$ (D) $r/4$

Ans: B

- Q.52** An electric machine will have high efficiency when
(A) input/output ratio is low (B) reactive power is more
(C) kWh consumption is low (D) losses are low

Ans: D

- Q.53** Which type of loss is not common to transformers and rotating machines?
(A) Eddy current loss (B) Copper loss
(C) Hysteresis loss (D) Windage loss

Ans: D

- Q.54** The difference between the synchronous speed and the actual speed of an induction motor is known as
(A) Regulation (B) back lash
(C) slip (D) lag

Ans: C

- Q.55** In two wattmeter method of power measurement, if one of the wattmeter shows zero reading, then it can be concluded that
(A) Power factor is unity (B) Power factor is zero
(C) Power factor is 0.5 lagging (D) Power factor is 0.5 leading

Ans: C

DE05
DE06

ELECTRICAL ENGINEERING
BASIC ELECTRONICS

- Q.56** Which of the following will remain the same in all parts of a series circuit?
(A) Voltage (B) Current
(C) Power (D) Resistance

Ans: B

- Q.57** Which single phase motor would you select for a tape recorder?
(A) Reluctance motor (B) Hysteresis motor
(C) Synchronous motor (D) Universal motor

Ans: B

- Q.58** Under the condition of resonance, RLC series circuit behaves as a,
(A) Purely resistive circuit. (B) Purely inductive circuit.
(C) Capacitive circuit. (D) Reactive circuit.

Ans:A

- Q.59** During charging, the electrolyte of a lead acid cell becomes
(A) Stronger. (B) Weaker.
(C) Water. (D) Diluted.

Ans:D

- Q.60** As compared to shunt and compound motors, series motor have the highest torque because of its comparatively _____ at the start.
(A) Lower armature resistance. (B) Stronger series field.
(C) Fewer series turns. (D) Larger armature current.

Ans:D

- Q.61** The input of an ac circuit having p.f. of 0.8 lagging is 20 kVA. The power drawn by the circuit is _____ kW.
(A) 12. (B) 20.
(C) 16. (D) 8.

Ans: C

- Q.62** The voltage ratio of the transformer is given as
(A) E_S/E_P (B) T_S/T_P
(C) T_P/T_S (D) E_P/T_S

Ans:A

- Q.63** The relationship between the frequency of ac wave and the time period is given by

DE05
DE06

ELECTRICAL ENGINEERING
BASIC ELECTRONICS

- Q.69** An emitter follower has high input impedance because
(A) large emitter resistance is used.
(B) large biasing resistance is used.
(C) there is negative feedback in the base emitter circuit.
(D) the emitter-base junction is highly reverse biased.

Ans: C

- Q.70** In a differential amplifier an ideal CMRR is
(A) infinity. (B) zero.
(C) -1. (D) +1.

Ans: A

- Q.71** FET is advantageous in comparison with BJT because of
(A) high input impedance. (B) high gain-bandwidth product.
(C) its current controlled behaviour. (D) high noise immunity.

Ans: A

- Q.72** The emission of electrons in a vacuum diode is achieved by
(A) electrostatic field. (B) magnetic field.
(C) heating. (D) electron bombardment.

Ans: C

- Q.73** The colour code of a resistor of nominal value $2.7\text{K}\Omega \pm 10\%$ is
(A) Red, violet, red and silver. (B) Red, violet, yellow and gold.
(C) Red, violet, orange and silver. (D) Red, violet, red and gold.

Ans: A

- Q.74** Capacitor that can have the highest capacitance value is
(A) Mica (B) Paper
(C) Electrolytic (D) Ceramic

Ans: C

- Q.75** The equivalent current-source representation for a voltage-source with open circuit voltage 12 V and internal resistance 3 ohms is
(A) a current-source of strength 4A in shunt with a resistance of 6Ω .
(B) a current -source of strength 4A in series with a resistance of 3Ω .
(C) a current-source of strength 4A in shunt with a resistance of 3 ohms.
(D) a current-source of strength 4A in shunt with a resistance of 36 ohms.

Ans: C

- Q.76** An intrinsic semiconductor at absolute zero temperature

DE05
DE06

ELECTRICAL ENGINEERING
BASIC ELECTRONICS

- (A) has a large number of holes.
- (B) behaves like an insulator.
- (C) behaves like a metallic conductor.
- (D) has few holes and same number of electrons.

Ans: A

- Q.77** The current flow through a Ge PN junction diode with a forward bias of 0.22 Volt and a reverse saturation current of 1 mA at 25° C is around
- (A) 6.3 A
 - (B) 5.22 A
 - (C) 4 mA
 - (D) 5.1 mA

Ans: B

- Q.78** For the operation of a depletion-type N-MOSFET, the gate voltage has to be
- (A) low positive
 - (B) high positive
 - (C) high negative
 - (D) zero

Ans: D

- Q.79** The typical operating voltage for LED's ranges from
- (A) 0.2 V to 0.6 V.
 - (B) 6 V to 10 V.
 - (C) 1.5 V to 2.5 V.
 - (D) 9 V to 10 V.

Ans: C

- Q.80** Capacitors for integrated circuits
- (A) cannot be made using diffusion techniques.
 - (B) can be made with very high values of capacitance.
 - (C) are always discrete components connected externally.
 - (D) can be made using silicon dioxide as the dielectric.

Ans: D

- Q.81** The magnitude of variation in the output voltage for a 10 V regulated dc power supply of 0.002% regulation will be
- (A) 0.2 mV.
 - (B) 0.002 mV.
 - (C) 0.02 mV.
 - (D) 0.2 μ V.

Ans: A

- Q.82** For the circuit shown in Fig.1, the output voltage is given by

DE05
DE06

ELECTRICAL ENGINEERING
BASIC ELECTRONICS

- (A) $v_o = \frac{R_F}{R_1}(v_2 - v_1)$.
- (B) $v_o = \frac{R_F}{R_1}(v_2 - v_1) - v_2$.
- (C) $v_o = \frac{R_F}{R_1}(v_2 - v_1) + v_2$.
- (D) $v_o = \frac{(v_2 - v_1)}{(R_1 + R_F)}$.

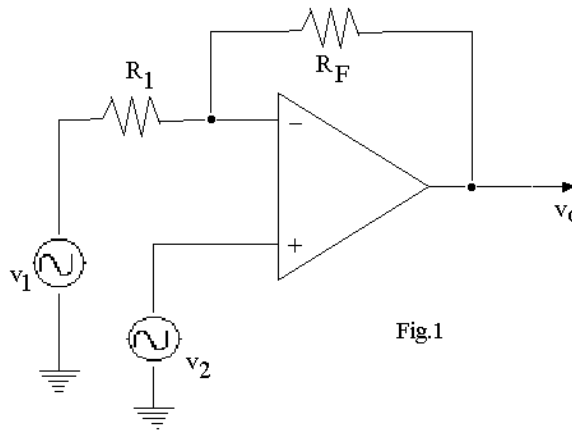


Fig.1

Ans: C

- Q.83 Which one of the following statements is not true?
- (A) Capacitance is a measure of a capacitor's capability to store charge.
- (B) A capacitor offers high impedance to ac but very low impedance to dc.
- (C) A capacitor is also used as bypass capacitor.
- (D) Capacitors are used to couple alternating voltages from one circuit to another and at the same time to block dc voltage from reaching the next circuit.

Ans: B

- Q.84 A voltage source having an open-circuit voltage of 100 V and internal resistance of $50\ \Omega$ is equivalent to a current source
- (A) 2A in parallel with $50\ \Omega$. (B) 2A with $50\ \Omega$ in series.
- (C) 0.5A in parallel with $50\ \Omega$. (D) 2A in parallel with $100\ \Omega$.

Ans: A

- Q.85 In a Zener diode large reverse current is due to
- (A) collision. (B) presence of impurities.
- (C) rupture of bonds (D) lower resistance in reverse biased region.

Ans: D

- Q.86 Ripple factor of a full-wave rectifier without filter will be
- (A) 0.2. (B) 0.48.
- (C) 0.24. (D) 1.21.

Ans: B

- Q.87 JFET has main drawback of
- (A) having low input impedance.
- (B) having high output impedance.
- (C) being noisy.

DE05
DE06

ELECTRICAL ENGINEERING
BASIC ELECTRONICS

(D) Having small gain-bandwidth product.

Ans: D

- Q.88** A UJT has
- (A) stable negative resistance characteristics.
 - (B) low firing current.
 - (C) use as a waveform generator.
 - (D) all of these characteristics.

Ans: D

- Q.89** For thermionic emission
- (A) a material with high work function is preferable.
 - (B) a material with low work function is preferable.
 - (C) the work function of the material has no importance.
 - (D) None of these is true.

Ans: B

- Q.90** Ideal operational amplifier has input impedance of
- (A) $1M\Omega$.
 - (B) infinity.
 - (C) zero.
 - (D) 1Ω .

Ans: B

- Q.91** The CE configuration amplifier circuits are preferred over CB configuration amplifier circuits because they have
- (A) lower amplification factor.
 - (B) Larger amplification factor.
 - (C) high input resistance and low output resistance.
 - (D) none of these.

Ans: B

- Q.92** The most commonly used type of electron emission in electron tubes is
- (A) Photo-electron emission.
 - (B) Thermionic emission.
 - (C) Field emission.
 - (D) Secondary emission.

Ans: A

- Q.93** The colour band sequence of a resistor is grey, Blue, gold, and gold. The range in which its value must lie so as to satisfy the tolerance specified is between
- (A) 7.5Ω and 8.5Ω
 - (B) $3.12K\Omega$ and $5.22K\Omega$
 - (C) $10.3K\Omega$ and $12.31K\Omega$
 - (D) 8.17Ω and 9.03Ω

Ans: D

DE05
DE06

ELECTRICAL ENGINEERING
BASIC ELECTRONICS

- Q.94** A device whose characteristics are very close to that of an ideal current source is
(A) a gas diode. (B) a BJT in CB mode.
(C) a BJT in CE mode. (D) a triode.

Ans: C

- Q.95** In an N-type semiconductor, the concentration of minority carriers mainly depends upon
(A) the doping technique. (B) the number of donor atoms.
(C) the temperature of the material (D) the quality of the intrinsic material, Ge or Si.

Ans: B

- Q.96** When forward bias is applied to a junction diode, it
(A) increases the potential barrier.
(B) decreases the potential barrier.
(C) reduces the majority-carrier current to zero.
(D) reduces the minority-carrier current to zero.

Ans: B

- Q.97** The theoretical maximum efficiency of a Bridge rectifier circuit is
(A) 48.2%. (B) 81.2%.
(C) 82%. (D) 40.6%.

Ans: B

- Q.98** The input resistance of a common-collector configuration will be of the order of
(A) $\simeq 90\text{K}\Omega$ (B) $\simeq 60\text{K}\Omega$
(C) $\simeq 150\text{K}\Omega$ (D) $300\text{K}\Omega$ and above

Ans: D

- Q.99** A switching voltage regulator can be of the following type:
(A) step-down (B) step-up
(C) inverting (D) none of these

Ans: A

- Q.100** A UJT contains
(A) four pn junctions (B) three pn junctions
(C) two pn junctions (D) one pn junction

Ans: D

- Q.101** The foundation on which an IC is built is called

DE05
DE06

ELECTRICAL ENGINEERING
BASIC ELECTRONICS

- Q.108** If a change in base current does not change the collector current, the transistor amplifier is said to be
- (A) Saturated. (B) Cut-off.
(C) Critical. (D) Complemented.

Ans: A

- Q.109** The extremely high input impedance of a MOSFET is primarily due to the
- (A) Absence of its channel.
(B) Negative gate-source voltage.
(C) Depletion of current carriers.
(D) Extremely small leakage current of its gate capacitor.

Ans: A

- Q.110** After firing an SCR, the gating pulse is removed. The current in the SCR will
- (A) Remains the same. (B) Immediately fall to zero.
(C) Rise up. (D) Rise a little and then fall to zero.

Ans: A

- Q.111** An inverting operational amplifier has $R_f = 2M\Omega$ and $R_1 = 2K\Omega$. Its scale factor is
- (A) 1000. (B) -1000 .
(C) 10^{-3} . (D) -10^{-3} .

Ans: B

- Q.112** In the context of IC fabrication, metallisation means
- (A) Connecting metallic wires.
(B) Forming interconnecting conduction pattern and bonding pads.
(C) Depositing SiO_2 layer.
(D) Covering with a metallic cap.

Ans: B

- Q.113** The colour band sequence of a resistor is yellow, violet, orange and gold. The range in which its value must lie so as to satisfy the tolerance specified is between
- (A) $40K\Omega$ and $42.5K\Omega$ (B) 44.65Ω and 49.3Ω
(C) $44.65K\Omega$ and $49.35K\Omega$ (D) $43.25K\Omega$ and $45.22K\Omega$

Ans: D

- Q.114** A device whose characteristics are very close to that of an ideal voltage source is
- (A) a vacuum diode. (B) a DIAC.
(C) a zener diode. (D) a FET.

Ans: C

DE05
DE06

ELECTRICAL ENGINEERING
BASIC ELECTRONICS

Q.115 The forbidden energy gap in semiconductors

- (A) lies just below the valance band
- (B) lies just above the conduction band
- (C) lies between the valence band and the conduction band
- (D) is the same as the valence band

Ans: C

Q.116 The barrier potential for a Ge PN junction is

- (A) 0.6V.
- (B) 0.3V.
- (C) 0.1V.
- (D) 0.5V.

Ans: B

Q.117 The ripple factor of a power supply is a measure of

- (A) its voltage regulation.
- (B) its diode rating.
- (C) purity of power output.
- (D) its filter efficiency.

Ans: C

Q.118 In a BJT, if the emitter junction is reverse-biased and the collector junction is reverse-biased, it is said to operate in

- (A) in active region
- (B) in saturation region
- (C) in cut-off region
- (D) none of the above

Ans: C

Q.119 In the switching type of voltage regulators, the power efficiency will be of the order of

- (A) 50% or less.
- (B) 60%.
- (C) 40% or more.
- (D) 90% or more.

Ans: D

Q.120 The resistance between bases of a UJT is typically in the range of

- (A) 2 to 3 K Ω
- (B) 5 to 10 K Ω
- (C) 15 to 20 K Ω
- (D) 18 to 20 K Ω

Ans: B

Q.121 The quantity that serves as a figure of merit for a DIFF AMP is

- (A) slew rate.
- (B) bandwidth.
- (C) input bias current.
- (D) CMRR.

Ans: D

Q.122 Practical range of resistance values obtainable with base diffused resistors is

DE05
DE06

ELECTRICAL ENGINEERING
BASIC ELECTRONICS

- (A) $10\ \Omega$ to $1\ \text{K}\Omega$ (B) $20\ \Omega$ to $30\ \text{K}\Omega$
(C) $5\ \Omega$ to $3\ \text{K}\Omega$ (D) $20\ \text{K}\Omega$ to $50\ \text{K}\Omega$

Ans: D

- Q.123** The colour band sequence of a resistor is Yellow, Violet, Orange and Gold. The range in which its value must lie so as to satisfy the tolerance specified is between
(A) $44.66\ \text{K}\Omega$ and $49.35\ \text{K}\Omega$ (B) $44.65\ \text{K}\Omega$ and $49.35\ \text{K}\Omega$
(C) $44.65\ \text{K}\Omega$ and $49.36\ \text{K}\Omega$ (D) $45\ \text{K}\Omega$ and $49.34\ \text{K}\Omega$

Ans: B

- Q.124** With increasing temperature, the resistivity of an intrinsic semiconductor decreases. This is because, with the increase of temperature
(A) The carrier concentration increases but the mobility of carriers decreases.
(B) Both the carrier concentration and mobility of carriers decreases.
(C) The carrier concentration decreases, but the mobility of carriers increases.
(D) The carrier concentration remains the same but the mobility of carriers decreases.

Ans: A

- Q.125** At room temperature of 25°C , the barrier Potential for Silicon is 0.7V . Its value at 0°C will be
(A) $0.7\ \text{V}$. (B) $0.65\ \text{V}$.
(C) $0.75\ \text{V}$. (D) $0.55\ \text{V}$.

Ans: C

- Q.126** Which of the following is a unipolar device?
(A) P-N junction diode (B) Zener diode
(C) Tunnel diode (D) Schottky diode

Ans: D

- Q.127** On applying a Positive voltage signal to the base of a normally biased N-P-N CE transistor amplifier
(A) Base current will fall.
(B) Collector current will fall.
(C) Emitter current will fall.
(D) Collector voltage will become less positive.

Ans: D

- Q.128** An N-channel JFET has Pinch-off Voltage of $V_p = -4\text{V}$ and given that $V_{GS} = -1\text{V}$, then the minimum V_{DS} for the device to operate in the Pinch-off region will be
(A) $+1\text{V}$ (B) $+3\text{V}$
(C) $+4\text{V}$ (D) $+5\text{V}$

DE05
DE06

ELECTRICAL ENGINEERING
BASIC ELECTRONICS

Ans: B

Q.129 The extremely high input impedance of a MOSFET is Primarily because of

- (A) Absence of its channel
- (B) Depletion of current carriers
- (C) Extremely small leakage current of its gate capacitor
- (D) Negative V_{GS}

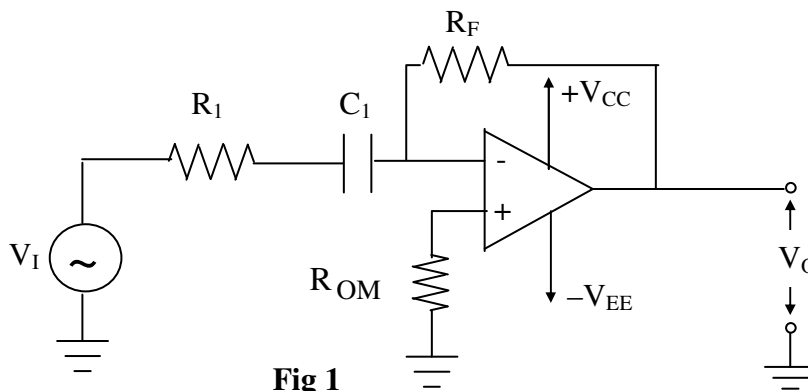
Ans: A

Q.130 When two identical SCRs are placed back-to-back in series with a load and if each is fired at 90° , then the voltage across the load will be

- (A) $\frac{2}{\pi} \times \text{Peak Voltage}$
- (B) Zero
- (C) $\frac{1}{\pi} \times \text{Peak Voltage}$
- (D) $\frac{1}{\sqrt{2}} \times \text{Peak Voltage}$

Ans: A

Q.131 In the differentiating circuit shown in Fig.1, the function of resistor R_1 is to



- (A) Enable the circuit to approach ideal differentiator
- (B) Maintain high input impedance
- (C) Eliminate high frequency noise spikes
- (D) Prevent oscillations at high frequencies

Ans:C

PART – II

DESCRIPTIVES

Q.1 Define the following and give their units of measurement:-

- (i) Resistance. (ii) Electric Potential.
(iii) Electric current. (2 x 3)

Ans:

(i) Resistance: - The opposition offered by a substance to the flow of electric current. The unit of resistance is ohm and given by the symbol Ω .

(ii) Electric Potential: -The capacity of a charged body to do work. The unit of electric potential is volt (V).

(iii) Electric Current: - The flow of free electrons constitutes electric current. The unit of electric current is called ampere (A).

Q.2 Give reasons, why, starters are required for starting a motor. (6)

Ans:

In case of DC motors, when the motor is at rest, the induced emf in the armature is zero. Consequently, if full voltage is applied across the motor terminals, the armature will draw heavy current because the armature resistance is relatively small. This heavy starting current will blow out the fuses and it may also damage the armature winding due to excessive heating effect. Excessive voltage drop will occur in the lines to which the motor is connected. To avoid this heavy current at start, a variable resistance is connected in series with the armature called starting resistance or starter, thus the armature current is limited to a safe value. Once the motor picks up speed, emf is built up and the resistance is gradually reduced. The whole resistance is taken out of circuit when the motor attains normal speed. The starter contains the protective device as overload protection coil (or relay), which provides necessary protection to the motor against overloading. In case of induction motors, the current drawn by the motor from the supply mains depends upon the rotor current. This current is very large as compared to its full load current. So when squirrel cage motors are directly connected to the supply mains, it draws very large current from the mains which effects in two ways – it produces very large voltage drop in the distribution lines and affects the voltage regulation of the supply system. It causes disturbance of the other motors connected to the same lines. Hence these motors should be started by means of some starting device known as starter.

Q.3 Why single phase induction motor are not self starting? (8)

Ans:

Single phase induction motor

Single phase induction motors set up pulsating torque, instead unidirectional and continuous torque. This is because force experienced by the current carrying conductors depends upon the direction of current and the magnitude of the flux. As an alternating current, direction and magnitude is changing so varying force is experienced by the conductors. Once in one

direction, say clockwise, then in other direction, i.e. anticlockwise. The change is so quick that neither it moves in a clockwise direction nor in an anticlockwise direction. However, if the motor is rotated by some means in any direction it will continue to rotate, even though the starting means have been withdrawn due to resultant torque in that direction. Hence we can say single phase motors are not self starting and certain means have to be used for starting single phase induction motors.

Q.4 State and explain Maximum power transfer theorem. Also give its applications. (8)

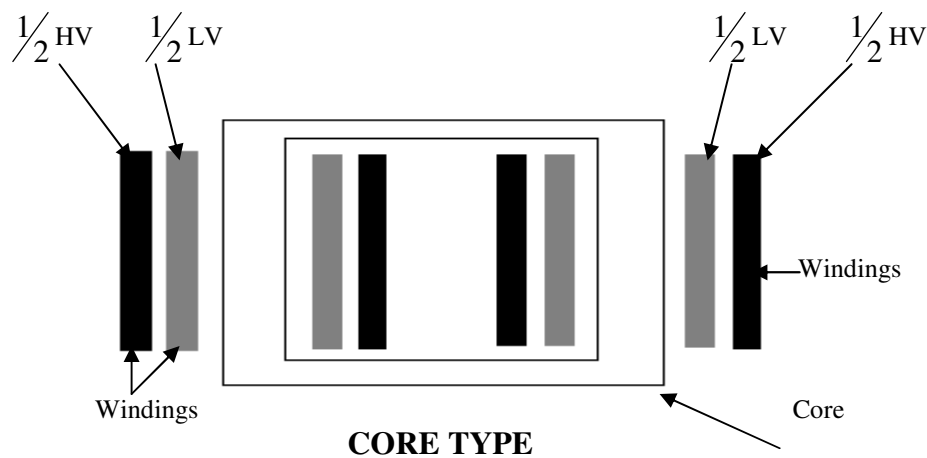
Ans:

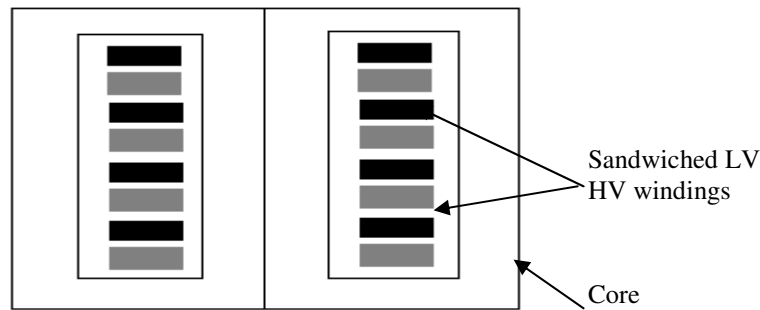
Maximum power transfer theorem deals with transfer of maximum power from the source to load. This theorem states the relationship between load resistance and internal resistance of the source for maximum power transfer from source to load. This condition is also referred to as impedance matching. Impedance matching is very important in electronic and communication circuits so as to obtain maximum power. Power transferred in an ac circuit is maximum when R_L (load resistance) = R_i (internal resistance of the source). This theorem is useful in electronic circuits where maximum power transfer is usually desirable such as Public address System. Also this theorem is applicable in starting of car engines.

Q.5 Based on the core construction, explain the two types of transformer. (8)

Ans:

Two types of core construction are adapted for transformers-core type and shell type. In the core type of construction, the LV and HV coils are interleaved to reduce the leakage flux. Half of LV and half HV are wound on each limb of the core type transformer. For economical insulation, the LV coils are placed next to the core and HV coils are placed on the outside. In the shell type transformer reduced leakage flux is obtained by sandwiching the LV and HV coils. The LV coils are sandwiched between the sections of the HV coil. Both the coils are placed on the central limb of the core.



**SHELL TYPE**

Q.6 Explain the word back emf used for a dc motor and highlight its significance. (6)

Ans:

The rotating conductors of the armature between the poles of magnet, in a DC motor, cut the magnetic flux, thereby developing an induced emf, which opposes the applied / external voltage. The induced emf set up in the coil of DC motor opposing the current flowing through the conductor, when the armature rotates, is called back emf. The value of the back emf depends upon the speed of rotation of the armature conductors. When the motor starts, the back emf in the beginning is zero. Consequently, the current flowing through the armature conductors is very large, since the armature resistance is very small. This current is very large and may damage the motor. In order to avoid this, additional resistance is connected in series with the armature to limit the current at starting.

Q.7 Write a note on selection of motors for specific engineering applications. (8)

Ans:

Selection of motors for different engineering applications:

Series motors are used in cranes, pumps, trains, trolleys, etc. due to its very high starting torque and variable speed.

Shunt motors run practically at constant speed at almost all loads. Such motors are used in lathes, drills, printing press and for driving pumps.

Cumulative compounds are used in machine tools, coal cutting machines, punch presser, crushers, compressor, rolling mills, elevators where very high starting torque is required and adjustable varying speed is required.

Three phase induction motors are used for high power applications such as in industries.

Single-phase motors are used in most homes, offices and rural areas.

Fractional kilowatt motors are used in fans, refrigerators, mixers, vacuum cleaners, washing machines, and small farming appliances.

Shaded pole motors are used in small fans, convectors, vending machines, photocopying machines, advertising displays.

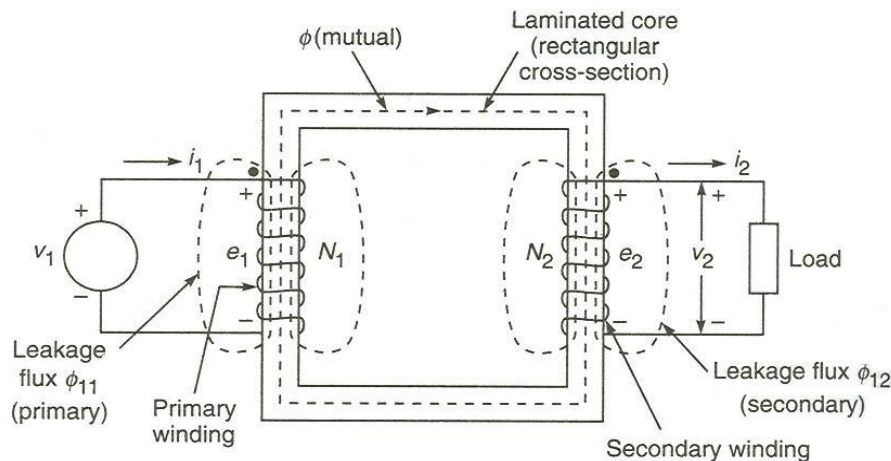
Q.8 Explain the principle of a transformer. (6)

Ans:

Working Principle of a transformer: The basic principle of a transformer is electromagnetic induction. It consists of two separate windings placed over the laminated silicon steel core.

The winding to which ac supply is connected is called primary winding and the winding to which load is connected is called a secondary winding. When ac supply of voltage v_1 is connected to primary winding, an alternating flux is set up in the core. This alternating flux when links with secondary winding, an emf is induced in it and is called mutually induced emf. The direction of this induced emf is opposite to the applied voltage v_1 . The same alternating flux also links with the primary winding and produces self-induced emf e_1 . Although there is no electrical connection between primary and secondary winding, but electrical power is transferred from primary circuit to the secondary circuit through mutual flux. The induced emf in the primary and secondary winding depends upon the rate of change of flux linkages (i.e. $N \frac{d\phi}{dt}$). The rate of change of flux ($\frac{d\phi}{dt}$) is same for both primary and secondary. Therefore, the induced emf in the primary is proportional to number of turns of the primary winding ($e_1 \propto N_1$) and in the secondary it is proportional to the number of turns

of the secondary windings ($e_2 \propto N_2$). In case $N_2 > N_1$ the transformer is step up and in case $N_2 < N_1$ the transformer is step down.



Q.9 Explain the term slip in an induction motor.

(4)

Ans:

Induction motor rotor always rotates at a speed less than synchronous speed. the difference between the flus speed (N_s) and the rotor speed (N) is called slip. It is usually expressed as a percentage of synchronous speed (N_s) and represented by the symbol 'S'.

$$\%S = \frac{N_s - N}{N_s} \times 100$$

DE05
DE06ELECTRICAL ENGINEERING
BASIC ELECTRONICS

Q.10 Differentiate between the 'squirrel cage' and 'phase wound' rotor types of induction motors. (8)

Ans:

Squirrel cage rotor	phase wound rotor
Almost constant speed but decreases slightly with increased load.	Speed decreases more rapidly than squirrel cage motor.
Starting torque is somewhat less, but running torque is good.	Starting torque is about three times the full load torque. Running torque is also good.
Starting current is about 5-6 times the full load current.	Starting current is about 2 times the full load current.
Speed control is done by changing poles.	Speed control is done by changing external resistance of rotor circuit.
Power factor is about 0.7 to 0.8.	Power factor is about 0.8 to 0.9.
Cost of fabrication is low.	Cost of fabrication is high.
Maintenance cost is very low.	Maintenance cost is high (because of extra resistance).
Application- lathes, drills, printing machines, blowers.	Applications – lifts, cranes, where high starting torque is needed.

Q.11 Explain application and advantages of storage batteries? (10)

Ans:

Applications of storage batteries: Because of the fact that storage batteries are portable, economical, efficient and reliable source of d.c. supply, they have a number of commercial applications. Some of the important applications are:-

- i) These are used for starting, ignition and lighting of automobiles, aircrafts etc.
- ii) For lighting on steam and diesel railways trains.
- iii) As a source of power supply in telephone exchange, laboratories and broadcast stations.
- iv) Used at generating stations and substations for operation of protective devices and for emergency lighting.
- v) For emergency lighting at hospitals, banks, rural areas where electricity supply is not possible.

Advantages of storage batteries

Following are the advantages of using storage batteries:-

- i) It is the highest and most efficient device for the storage of energy in portable form.
- ii) The stored energy is available immediately because there is no lag of time for delivering the stored energy.
- iii) The energy storing in the battery may be done at any convenient rate and delivered at any other rate.
- iv) It is very reliable source for supply of energy.

DE05
DE06

ELECTRICAL ENGINEERING
BASIC ELECTRONICS

v) The energy can be drawn at a fairly constant rate.

Q.12 How does a three-phase synchronous motor differ from a three-phase induction motor? Give a few applications of synchronous motors. (8)

Ans:

Synchronous motor is not self-starting and requires starting devices. It runs only at synchronous speed. So the speed is constant. It has to be synchronized. It can be operated under a wide range of p.f. both leading and lagging. The change in the applied voltage, does not cause much effect on its torque. It is more costly and complicated. The breakdown torque is approximately proportional to applied voltage. Where as induction motors are self-starting and do not require any starting devices. Its speed decreases with load and it has not to be synchronized. It always runs at lagging p.f., whose value becomes very low at light loads. The change in the applied voltage causes much effect on its torque. It is simple, rugged and low in cost. The breakdown torque depends on the square of the applied voltage.

Applications: Synchronous motors are used to improve power factor of large industries, in substations. It is used to control the voltage at the end of transmission line by varying their excitation. Also used in textile mills, cement factories, mining industries and rubber mills for power applications. They are also used to drive constant speed equipment such as centrifugal pumps, centrifugal fans, air compressors, motor-generator sets, and blowers.

Q.13 Explain the different methods for the starting of a synchronous motor. (6)

Ans:

Starting methods: Synchronous motor can be started:

- (1) by means of an auxiliary motor: In this case, an auxiliary motor rotates the rotor of synchronous motor. Then rotor poles are excited due to which the rotor field is locked with the stator revolving field and continuous rotation is obtained.
- (2) By providing damper winding: In this case, bar conductors are embedded in the outer periphery of the rotor poles and are short-circuited with the short-circuiting rings at both sides. The machine is started as a squirrel cage induction motor first. When it picks up speed, excitation is given to the rotor and the rotor starts rotating continuously as the rotor field is locked with stator revolving field.

Q.14 Name the types of motors used in: vacuum cleaners, phonographic appliances, vending machines, refrigerators, rolling mills, lathes, power factor improvement and cranes. (8)

Ans:

Motors used are: -

Vacuum cleaners- Universal motor.

Phonographic appliances – Hysteresis motor.

Vending machines – Shaded pole motor.

Refrigerators – Capacitor split phase motors.

Rolling mills – Cummulative motors.

Lathes – DC shunt motors.

Power factor improvement – Synchronous motors.

DE05
DE06

ELECTRICAL ENGINEERING
BASIC ELECTRONICS

Cranes – DC series motors.

Q.15 Name the different types of 1-phase A.C motors. Give some important application of these motors. (8)

Ans:

Different types of 1-phase AC motors and their applications:

- i) Single phase Induction motor:- These motors are of different types
 1. Capacitor start single phase induction motor is generally used for fans, refrigerator, washing machines, blowers and centrifugal pumps etc.
 2. Split phase induction motor is used in bench grinder, drills etc.
 3. Shaded pole single phase induction motor is used in electric record players, slide projectors etc.
- ii) Due to high efficiency and good speed of motor, universal motor is used for vacuum cleaners, electric type writers etc.
- iii) Reluctance motor is used in electric clocks due to constant speed.
- iv) Hysteresis motor is used in record player, tape recorders and clocks due to steady hysteresis torque.

Q.16 With the help of a neat sketch explain the various parts of a nuclear reactor. (8)

Ans:

Parts of a nuclear reactor: The fission of a nuclear material is carried out in a nuclear reactor.

Fuels: - used in the reactor have some components of ^{238}U . In advanced gas cooled reactor enriched uranium dioxide fuel in pellet form encased in stainless steel cans is used. The fuel could be in the form of rods enclosed in stainless steel.

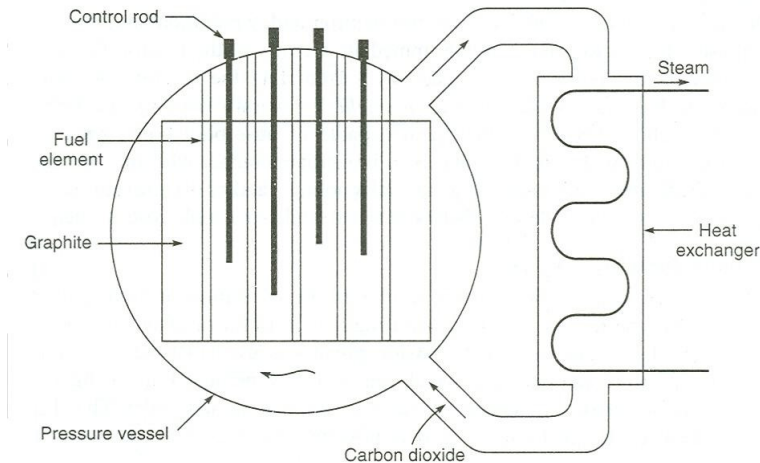
Moderators: - are used to slow down the neutrons. Commonly used moderators are graphite, light water and heavy water.

Coolants: - these remove the heat generated in the core by circulation and transfer it outside for raising steam. Common coolants are light ordinary water, heavy water, CO_2 gas and also metals like sodium or sodium- potassium alloy in liquid form.

Control Materials: - control is achieved by means of a neutron absorbing material. The control elements are commonly located in the core in the form of either rods or plates. The most commonly used neutron absorber is boron.

Reactor Shield: - surrounding the reactor core with a radiation shield makes provisions for health protection. This is also called biological shield.

The energy given off in a reactor appears in the form of heat, which is removed by a gas or liquid coolant. The hot coolant is then used in a heat exchanger to raise steam. If the coolant is ordinary water, steam could be raised inside the reactor. This steam runs a turbo generator for producing electric energy.



Nuclear reactor

Q.17 Define the following terms:

(i) Diversity Factor.

(ii) Annual Load Factor.

(iii) Capacity Factor.

(6)

Ans:

$$\text{Diversity Factor} = \frac{\sum \text{individual maximum demands of consumers}}{\text{Maximum load on the system}}$$

$$\text{Annual load factor} = \frac{\text{Total annual load (Mwh)}}{\text{Annual peak load (MW) X 8760 h}}$$

$$\text{Capacity factor} = \frac{\text{Actual annual generation (Mwh)}}{\text{Maximum rating (Mw) X 8760 h}}$$

Q.18 Write note on Energy storage.

(7)

Ans:

Energy storage: - Large-scale storage of energy, which can be quickly converted to electrical form, can help fast changing loads. The options available are pumped storage, compressed air storage, heat storage, hydrogen storage and batteries.

Pumped storage: - In areas where sufficient hydrogeneration is not available, peak load may be handled by means of pumped storage. This consists of upper and lower reservoirs and reversible turbine-generator sets, which can also be used as motor –pump sets. The upper reservoir has enough storage for full load generations.

Compressed air storage: - Compressed air can be stored in natural underground caverns or old mines. The energy stored equals the volume of air multiplied by pressure. At times of need, this air can be mixed with gas fuel to run a gas turbine.

Heat storage:- Water with good specific and latent heat has been used. In generating stations, boilers can be kept ready on full steam for the turbine to pick up fast rising load. Boiler steam, when not in use can heat feed water for boilers in the station.

DE05
DE06ELECTRICAL ENGINEERING
BASIC ELECTRONICS

Secondary batteries: - These have possible use in local fluctuating loads, electric vehicles and back up for wind and solar power. There are a number of batteries like lead acid cell, nickel cadmium cell and sodium sulphur cell.

Q.19 State the following:

- (i) Thevenin's Theorem.
- (ii) Norton's Theorem.
- (iii) Maximum power transfer theorem.
- (iv) Kirchoff's laws. (8)

Ans:

(i) Thevenin's Theorem states that the current flowing through a load resistance R_L connected across any two terminals A and B of a linear, active bilateral network is given by $V_{oc} / (R_i + R_L)$ where V_{oc} is the open circuit voltage (ie. the voltage across the two terminals when R_L is removed) and R_i is the internal resistance of the network as viewed back into the open circuited network from terminals A and B with all voltage sources replaced by their internal resistance (if any) and current sources by infinite resistance.

(ii) Norton's Theorem states that any two – terminal active network containing voltage sources and resistances when viewed from its output terminals, is equivalent to a constant current source and parallel resistance. The constant current is equal to the current which would flow in a short circuit placed across the terminals and parallel resistance is the resistance of the network when viewed from these open circuited terminals after all voltage and current sources have been removed and replaced by their internal resistances.

(iii) Maximum power transfer theorem: A resistive load will abstract maximum power from a network when the load resistance is equal to the resistance of the network as viewed from the output terminals, with all energy sources removed leaving behind their internal resistances.

(iv) Kirchoff's first law states that the algebraic sum of all currents meeting at a point is zero.
 $\Sigma I = 0$.

Kirchoff's second law states that, in a closed circuit, the algebraic sum of all the emf's plus the algebraic sum of all the voltage drops (i.e. product of current and resistances) is zero.

$$\Sigma I R + \Sigma \text{emf} = 0.$$

Q.20 Write short notes on

- (i) Different losses in transformer. (8)
- (ii) Resonance in R-L-C series circuit. (8)

Ans:

(i) Different losses in transformer

There are two types of losses occurring in transformer:

1. **Constant losses or Iron losses:** These losses occur in the core, therefore known as core losses or iron losses. There are two types of iron losses, one is the eddy current loss and other is hysteresis loss. These losses depend upon the supply voltage, frequency, core material and its construction. As long as supply voltage and frequency is constant, these losses remain the same whether the transformer is loaded or not. Hence core losses are known as constant losses.

2. **Variable losses or copper losses:** When the transformer is loaded, current flows in primary and secondary windings and there is loss of electrical energy due to the resistance of the primary winding and secondary winding. If current in primary is I_1 amp and in secondary is I_2 amp and primary resistance is r_1 and secondary resistance is r_2 ohms then total copper losses are equal to $I_1^2 r_1 + I_2^2 r_2$. In fact these losses are winding material losses; therefore, these are known as copper losses. These losses depend upon the loading conditions of the transformers. Therefore, these losses are also called as variable losses.

(ii) **Resonance in R-L-C Series circuit:** A circuit in which the two components L and C are connected in series with each other across a variable frequency a.c. source is called a series resonance circuit as shown in fig.9(a)

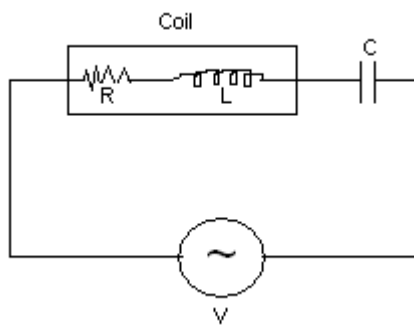


Fig 9(a)

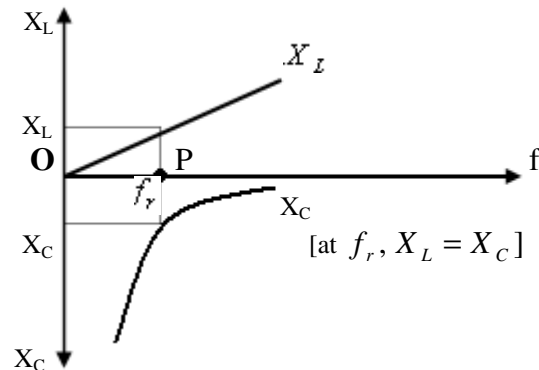


Fig 9(b)

If the frequency of the voltage source is varied, then the value of inductive reactance X_L and capacitor reactance X_C at a particular frequency can be given as $X_L = 2\pi fL$, $X_C = 1/2\pi fC$

The total impedance of the circuit will be given as $Z = \sqrt{R^2 + (X_L - X_C)^2}$

Where R is the resistance of the circuit which may be resistance of the coil.

It is clear from the above equation that X_L increases linearly with frequency whereas X_C decreases inversely with frequency as shown in the fig. 9b. There will be a particular frequency at which X_L is equal to X_C . This frequency is called resonance frequency (f_r). At this frequency $Z = R$ and circuit will behave as purely resistive circuit.

At resonant frequency $X_L = X_C$

$$2\pi f_r L = 1/2\pi f_r C$$

$$f_r^2 = 1/4\pi^2 LC$$

$$f_r = 1/2\pi\sqrt{LC}$$

Q.21 What are the different types of D.C motors? Give their applications? (8)

Ans:

Different type of DC motors and their applications are as follows:-

1. **Shunt motors:** Shunt motor is a fairly constant speed motor though its starting torque is not very high. Hence it is suitable for constant speed drive which do not

DE05
DE06

ELECTRICAL ENGINEERING
BASIC ELECTRONICS

require very high starting torque such as pumps, blowers, fan, lathe machines, tools' belt or chain conveyor etc.

2. **Service motors:** This motor develops a high starting torque & its speed is inversely proportional to the loading conditions i.e. when lightly loaded, the speed is high and when heavily loaded, it is low. Therefore, motor is used in lifts, cranes, traction work, coal loader and coal cutter in coal mines etc.
3. **Compound motors:** This motor has a variable speed and high starting torque. It can also run at NIL loads without any danger. This motor will therefore find its application in loads having high inertia load or requiring high intermittent torque such as elevators, conveyor, rolling mill, planes, presses, shears and punches, coal cutter and winding machines etc.

Q.22 Derive the emf equation of a transformer. (6)

Ans:

When a sinusoidal voltage is applied to the primary winding of a transformer, a sinusoidal flux as shown in the fig. is set up in the iron core which links with the primary and secondary winding. Let ϕ_m = maximum value of flux in wb, f = supply frequency in Hz. N_1 = No. of turns of the primary and N_2 = No. of turns of secondary. As shown in the fig. the flux changes from $+\phi_m$ to $-\phi_m$ in half a cycle i.e. $1/2f$ seconds.

$$\text{Average rate of change of flux} = \frac{\phi_m - (-\phi_m)}{1/2f} = 4 \phi_m f \text{ wb/s}$$

Now, the rate of change of flux per turn is the average induced emf per turn in volts.

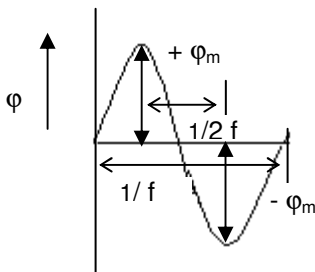
Therefore, average induced emf / turn = $4 \phi_m f$ volts.

For a sinusoidal wave, R.M.S. value / Average value = Form factor = 1.11

Therefore, R.M.S. value of emf induced / turn, $E = 1.11 \times 4 \phi_m f$ volts.

Therefore, R.M.S. value of emf induced in primary, $E_1 = (\text{emf induced/ turn}) \times \text{No. of primary turns.} = 4.44 N_1 f \phi_m$ volts.

Similarly R.M.S. value of emf induced in secondary, $E_2 = (\text{emf induced/ turn}) \times \text{No. of secondary turns.} = 4.44 N_2 f \phi_m$ volts.



Q.23 What are the different methods of measurement of power in 3-phase circuit. Explain two wattmeter method in brief. (8)

Ans:

Following methods are available for measuring power in 3-phase circuit

- i) Three wattmeter method
- ii) Two wattmeter method
- iii) One wattmeter method

Two wattmeter method: In this method Two wattmeters are used for power measurement. As shown in fig.3a, the current coils of two wattmeters are inserted in any two line and the voltage coil of each joined to the 3rd line. It can be proved that the sum of the instantaneous power indicated by W_1 and W_2 gives the instantaneous power absorbed by the three loads L_1, L_2 & L_3 .

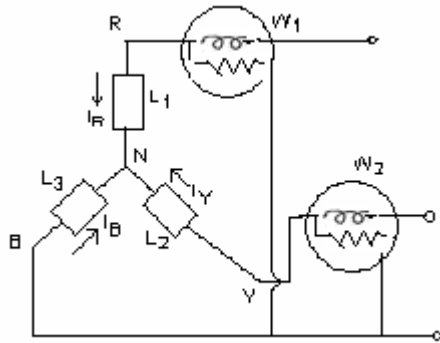


Fig 3a

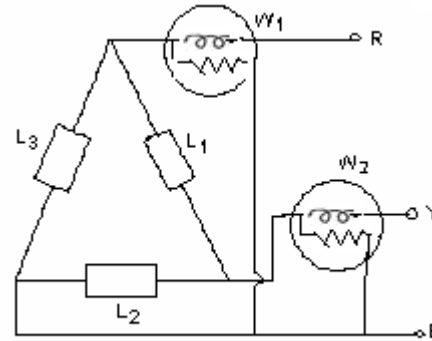


Fig 3b

This method can be applied to star connected as well as delta connected load. Considering star connected load

Instantaneous current through $W_1 = i_R$

Instantaneous Voltage across $W_1 = e_{RB} = e_R - e_B$

Instantaneous Power read by $W_1 = i_R(e_R - e_B)$

Instantaneous current through $W_2 = i_Y$

Instantaneous Voltage across $W_2 = e_{YB} = e_Y - e_B$

Instantaneous Power read by $W_2 = i_Y(e_Y - e_B)$

Therefore $W_1 + W_2 = i_R(e_R - e_B) + i_Y(e_Y - e_B)$

$$= i_R e_R + i_Y e_Y - e_B (i_Y + i_R)$$

Now $i_R + i_Y + i_B = 0$ by kirchoffs point law

$$(i_Y + i_R) = -i_B$$

$$W_1 + W_2 = i_R e_R + i_Y e_Y + i_B e_B = p_1 + p_2 + p_3$$

Where p_1 is the power absorbed by L_1 , p_2 that absorbed by L_2 and p_3 that absorbed by L_3

$W_1 + W_2 =$ total power absorbed

Hence in two wattmeter method the sum of readings of two wattmeters gives the total power absorbed by 3- Φ circuit.

Q.24 Explain the process of commutation in a dc machine. Explain what are inter-poles and why they are required in a dc machine. **(8)**

Ans:

Commutation: When an armature coil moves under the influence of one pole- pair, it carries constant current in one direction. As the coil moves into the influence of the next pole- pair, the current in it must reverse. This reversal of current in a coil is called commutation. Several coils undergo commutation simultaneously.

The reversal of current is opposed by the static coil emf and therefore must be aided in some fashion for smooth current reversal, which otherwise would result in sparking at the brushes. The aiding emf is dynamically induced into the coils undergoing commutation by means of **compoles** or **interpoles**, which are series excited by the armature current. These are located in the interpolar region of the main poles and therefore influence the armature coils only when these undergo commutation.

Q.25 What are the different network theorems? State Thevenin's theorem. (6)

Ans:

There are a number of theorems to solve electrical networks. Some of the important network theorems are:

- i. Thevenin's Theorem
- ii. Norton's Theorem
- iii. Super Position Theorem
- iv. Maximum Power Transfer Theorem

Thevenin's Theorem: It states that any two terminal linear networks containing a number of e.m.f. sources and impedances may be replaced by an equivalent circuit consisting of a voltage generator (V_{th}) in series with an impedance (R_{th}). This circuit will be called as Thevenin's equivalent circuit.

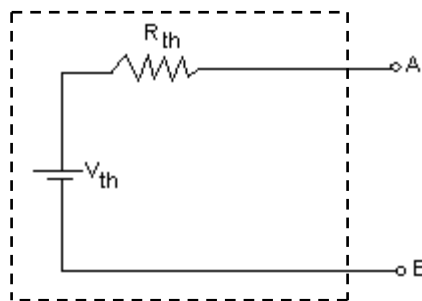


Fig 2a

Where V_{th} – Thevenin's equivalent voltage (open circuit voltage across terminal AB)

R_{th} – Thevenin's equivalent impedance (Resistance between terminal AB when all emf sources in the network are reduced to zero.)

Q.26 Explain the operation of a three phase induction motor. (6)

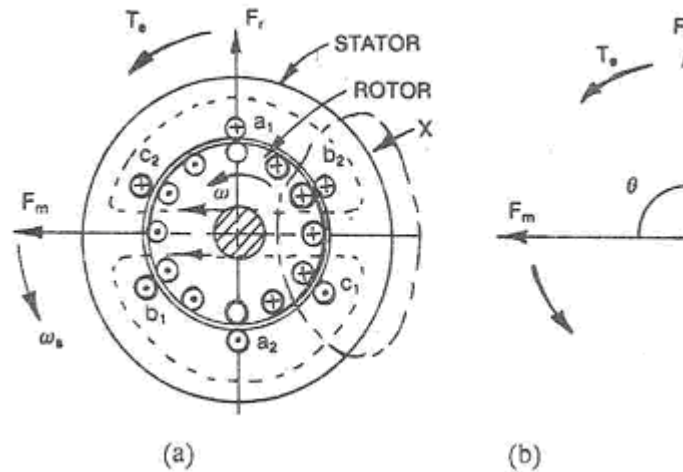
Ans:

Operation of a 3- phase induction motor: When the 3- phase supply is given to the stator of a 3- phase wound induction motor, a rotating field is set-up in the stator. At any instant

DE05
DE06

ELECTRICAL ENGINEERING
BASIC ELECTRONICS

the magnetic field set up by the stator is shown in fig. An arrowhead F_m marks the direction of resultant field. Let this field be rotating in an anti-clockwise direction at an angular speed of ω_s radians per second i.e. Synchronous speed. The stationary rotor conductors cut the revolving field and due to electromagnetic induction an emf is induced in the rotor conductors. As the rotor conductors are short circuited, current flows through them in the direction as marked in the fig. Rotor current carrying conductors set up a resultant field F_r . This tries to come in line with the stator main field F_m . Due to this an electromagnetic T_e is developed in the anticlockwise direction. Thus, the rotor starts rotating in the same direction in which stator field is revolving.



Q.27 Explain the working principle of operation of a single phase transformer. (6)

Ans:

Working principle of operation of a single phase transformer: When AC supply is given to the primary winding, a current will start flowing in the primary. This will set up flux. This flux is linked with primary and secondary windings. Hence voltage is induced in both the windings. Now, if load is connected to the secondary side, then current will start flowing in the load in the secondary winding, resulting in flow of additional current in the secondary winding. Hence according to Faraday's laws of electromagnetic induction, emf will be induced in both the windings. The voltage induced in the primary winding is due to its self inductance and known as self induced emf and according to Lenz's law it will oppose the cause i.e. supply voltage hence called as back emf. The voltage induced in secondary coil is known as mutually induced voltage. Hence transformer works on the principle of electromagnetic induction.

Q.28 Define the following terms:-
Reliability, Maximum demand, Reserve-generating capacity, Availability (operational).

(8)

Ans:

Reliability: It is measure by the power system's ability to serve all power demands without failure over long periods of times.

Maximum Demand: It is the greatest demand of load on the power station during a given period.

Reserve generating capacity: Modern generating plants are stressed to limits of temperature and pressure to reduce the overall power costs. Therefore, extra generation capacity must be installed to meet the need of scheduled downtimes for preventive maintenance.

Availability: As the percentage of the time a unit is available to produce power whether needed by the system or not.

Q.29 What are the disadvantages of low power factor? How can it be improved? (8)

Ans:

Disadvantages of low power factor:

- 1) Line losses are 1.57 times those at unity power factor.
- 2) Larger generators and transformers are required.
- 3) Low lagging power factor causes a large voltage drop, hence extra regulation equipment is required to keep voltage drop within prescribed limits.
- 4) Greater conductor size: To transmit or distribute a fixed amount of power at fixed voltage, the conductors will have to carry more current at low power factor. This requires a large conductor size.

Methods of improving power factor:

- 1) Static Capacitors: The static capacitors are connected in parallel with the load operating at lagging power factor.
- 2) A synchronous motor takes a leading current when over excited and therefore behaves like a capacitor.
- 3) Phase advancers: Are used to improve the power factor of induction motors. It provides exciting ampere turns to the rotor circuit of the motor. By providing more ampere-turns than required, the induction motor can be made to operate on leading power factor like an over-excited synchronous motor.

Q.30 Explain why the following motors are used in the particular applications indicated against them. Synchronous motors – power-factor improvement, DC shunt motors – lathes, DC series motors- lifts and cranes, Cumulative compound motor – rolling mills. (8)

Ans:

Synchronous motors – power factor improvement- the power factor of the motor can be controlled over a wide range by adjusting its excitation. Since it can be operated under a wide range of power actors both lagging and leading by its field current it is used in power factor improvement.

DC shunt motors – Lathes - shunt motor is almost constant speed motor. It is used where the speed between no loads to full load has to be maintained almost constant.

DE05
DE06

ELECTRICAL ENGINEERING
BASIC ELECTRONICS

DC series motors- lifts and cranes – series motor is a variable speed motor. It is used where high torque is required at the time of starting to accelerate heavy loads.

Cumulative compound motor- rolling mills – Unlike a series motor, it has a finite no-load speed but speed drops sharply relieving the peak power drawn from the mains as the billet is passed through rolls.

Q.31 What are the advantages and disadvantages of high voltage DC transmission? (8)

Ans:

Advantages of the high voltage DC transmission are:

- These systems are economical for long distance bulk power transmission by overhead lines.
- There is greater power per conductor and simpler line construction.
- Ground return is possible.
- There is no charging current.
- The voltage regulation problem is much less serious for DC since only the IR drop is involved ($IX = 0$).
- There is reversibility and controllability of power flow through a DC link.
- The DC line is an asynchronous or flexible link and it can interconnect two rigid systems operating at different frequencies.
- Smaller amount of right of way is required. The distance between two outside conductors of a 400kV AC line is normally 20m, whereas the same between a corresponding DC line is roughly half.
- Line losses are smaller.
- There is considerable insulation economy. The peak voltage of the 400 kV AC line is $\sqrt{2} \times 400 = 564\text{kV}$. So the AC line requires more insulation between the tower and conductors, as well as greater clearance above the earth as compared to corresponding 400 kV DC line.

The disadvantages of high voltage DC transmission are:

- The systems are costly since installation of complicated converters and DC switchgear is expensive.
- Converters require considerable reactive power.
- Harmonics are generated which require filters.
- Converters do not have overload capability.
- Lack of HVDC circuit breakers hampers multiterminal or network operation. There is nothing like DC transformer which can change the voltage level in a simply way.
- Reactive power required by the load is to be supplied locally as no reactive power can be transmitted over a DC link.

Q.32 Explain the following terms – Busbar, load, system, outage. (8)

Ans:

Busbar – It is a solid electrical connection made of aluminium or copper bars connecting various power system components like generators, transformers, lines, loads.

DE05
DE06

ELECTRICAL ENGINEERING
BASIC ELECTRONICS

Load – It is a device or devices which draw electrical power from the busbar to do useful work for the consumers, drive motors and other processes in industry, in domestic load it is lighting, refrigeration, small electrical appliances.

System – The complete electrical networks, prime movers, generators, transformers, lines and loads.

Outage – Removal of a circuit either deliberately or inadvertently.

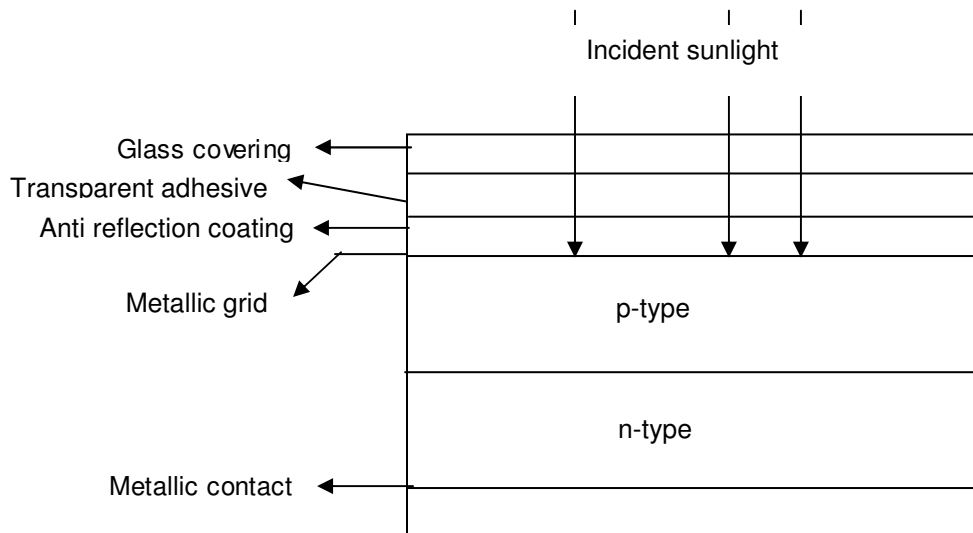
Q.33 State a few applications of solar energy. Also explain the structure of a solar photovoltaic cell. (2+6)

Ans:

Applications of solar energy: Solar energy is used in water heating, solar drying, desalination, industrial process heating and passive / active heating of buildings. Also solar radiation is used to heat a working fluid, which runs turbines. Also solar photovoltaic are widely used in satellites in space, for meeting energy requirements of defence personnel stationed at remote areas.

The structure of a solar photovoltaic cell is:

The top layer is glass cover, transparency 90 –95 %. Its purpose is to protect the cell from dust, moisture etc. The next is a transparent adhesive layer, which holds the glass cover. Underneath the adhesive is an antireflection coating to reduce the reflected sunlight to below 5 %. Then follows a metallic grid, which collects the charge carriers, generated by the cell under incidence of sunlight, for circulating to outside load. Under the lower side of the metallic grid lies a p-layer followed by n-layer forming a pn- junction at their interface. The thickness of the top p- layer is so chosen that enough photons cross the junction to reach the lower n-layer. Then follows another metallic grid in contact with the lower n- layer. This forms the second terminal of the cell.



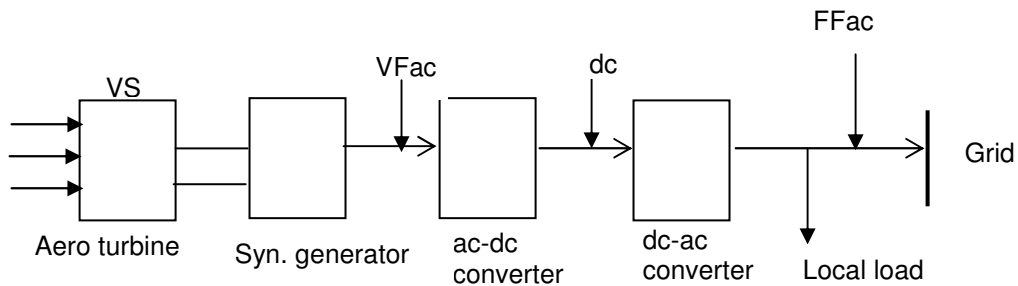
Structure of a photovoltaic cell

Q.34 State the factors, for the choice of electrical system for an aero turbine. Also draw the block diagram of VSCF wind electrical system. What are the advantages of VSCF wind electrical system? (2+2+4)

Ans:

The choice of electrical system for an aero turbine is guided by three factors:

1. Type of electrical output: dc, variable- frequency ac, and constant- frequency ac.
2. Aero turbine rotational speed: constant speed with variable blade pitch, nearly constant speed with simpler pitch- changing mechanism or variable speed with fixed pitch blades.
3. Utilization of electrical energy output: in conjunction with battery or other form of storage, or interconnection with power grid.



**Block diagram of VSCF wind electrical system:
VF(variable frequency), FF (fixed frequency)**

Advantages of VSCF wind electrical system are:

1. No complex pitch changing mechanism is needed.
2. Aero turbine always operates at maximum efficiency point.
3. Extra energy in the high wind speed region of the speed – duration curve can be extracted.
4. Significant reduction in aerodynamic stresses, which are associated with constant – speed operation.

Q.35 Derive the equivalent star circuit from a delta circuit. (8)

Ans:

Delta/Star Transformation: Consider three resistors R_{AB} , R_{BC} , R_{CA} connected in delta to three terminals A, B, C as shown in the Fig 2 (a). Let the equivalent star- connected network have resistances R_A , R_B and R_C (Fig 2(b)). Since the two arrangements are electrically equivalent, the resistance between any two terminals of one network is equal to the resistance between the corresponding terminals of the other network.

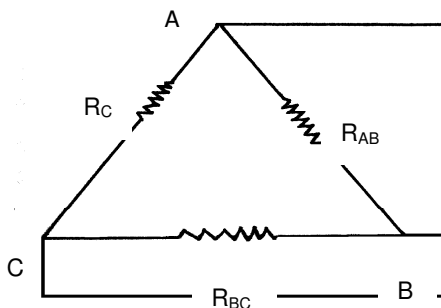


Fig 2(a)

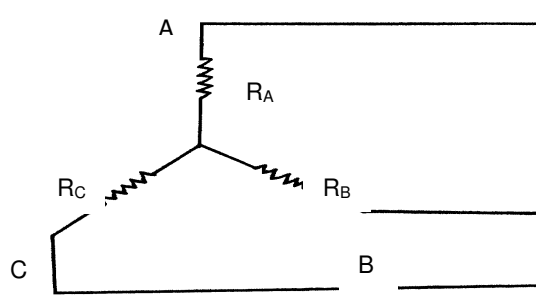


Fig 2(b)

Consider the terminals A and B of the network. R_{AB} , R_{BC} , R_{CA} are connected in delta. Equivalent star connected network has resistances R_A , R_B and R_C .

Resistance between A and B for star = Resistance between A and B for delta

$$R_A + R_B = R_{AB} \parallel (R_{BC} + R_{CA})$$

or
$$R_A + R_B = \frac{R_{AB}(R_{BC} + R_{CA})}{R_{AB} + R_{BC} + R_{CA}} \quad (i)$$

Similarly
$$R_B + R_C = \frac{R_{BC}(R_{CA} + R_{AB})}{R_{AB} + R_{BC} + R_{CA}} \quad (ii)$$

$$R_C + R_A = \frac{R_{CA}(R_{AB} + R_{BC})}{R_{AB} + R_{BC} + R_{CA}} \quad (iii)$$

Adding (i),(ii) and (iii)

$$R_A + R_B + R_C + R_C + R_C + R_A = \frac{R_{AB}(R_{BC} + R_{CA})}{R_{AB} + R_{BC} + R_{CA}} + \frac{R_{BC}(R_{CA} + R_{AB})}{R_{AB} + R_{BC} + R_{CA}} + \frac{R_{CA}(R_{AB} + R_{BC})}{R_{AB} + R_{BC} + R_{CA}}$$

By adding,

$$2(R_A + R_B + R_C) = \frac{R_{AB}R_{BC} + R_{AB}R_{CA} + R_{BC}R_{CA} + R_{BC}R_{AB} + R_{CA}R_{AB} + R_{CA}R_{BC}}{R_{AB} + R_{BC} + R_{CA}}$$

$$2(R_A + R_B + R_C) = 2 \left[\frac{(R_{AB}R_{BC} + R_{AB}R_{CA} + R_{BC}R_{CA})}{R_{AB} + R_{BC} + R_{CA}} \right]$$

$$\text{or } R_A + R_B + R_C = \frac{(R_{AB}R_{BC} + R_{AB}R_{CA} + R_{BC}R_{CA})}{R_{AB} + R_{BC} + R_{CA}} \quad (iv)$$

Subtracting (i) from (iv)

$$R_C = \frac{R_{CA}R_{BC}}{R_{AB} + R_{BC} + R_{CA}} \quad (v)$$

$$R_B = \frac{R_{BC}R_{AB}}{R_{AB} + R_{BC} + R_{CA}} \quad (vi)$$

$$R_A = \frac{R_{AB}R_{CA}}{R_{AB} + R_{BC} + R_{CA}} \quad (vii)$$

Q.36 Explain the uses of: shaded – pole motor, capacitor start motor, DC series motor and DC shunt motor. (8)

Ans:

Shaded pole motors - are used in small fans, convectors, vending machines, photocopying machines, advertising displays.

Capacitor start motors – It have larger starting torque and is used in machine tools, refrigeration, and air-conditioning.

DC series motors- lifts and cranes – series motor is a variable speed motor. It is used where high torque is required at the time of starting to accelerate heavy loads.

DE05
DE06

ELECTRICAL ENGINEERING
BASIC ELECTRONICS

DC shunt motors – Lathes, drills, printing press and for driving pumps.- Shunt motor is almost constant speed motor. It is used where the speed between no loads to full load has to be maintained almost constant.

Q.37 Explain the terms real power, apparent power and reactive power for ac circuits and also the units used. (6)

Ans:

Real Power: is equal to the product of voltage, current and power factor i.e.

Power = voltage X current X power factor or $P = V I \cos \phi$ and basic unit of real power is watt. i.e. Expressed as W or kW.

Apparent power: is equal to the product of voltage and current

Apparent power = voltage X current or Apparent power = $V I$ and basic unit of apparent power is volt- ampere. Expressed as VA or KVA.

Reactive Power: is equal to the product of voltage, current and sine of angle between the voltage and current i.e.

Reactive power = voltage X current X $\sin \phi$ or Reactive power = $V I \sin \phi$ and has no other unit but expressed in VAR or KVAR.

Q.38 Explain how motors are selected for specific engineering applications. (8)

Ans:

Selection of motors for different engineering applications:

Series motors are used in cranes, pumps, trains, trolleys, etc. due to its very high starting torque and variable speed.

Shunt motors runs practically at constant speed at almost all loads. Such motors are used in lathes, drills, printing press and for driving pumps.

Cumulative compounds are used in machine tools, coal cutting machines, punch presser, crushers, compressor, rolling mills, elevators where very high starting torque is required and adjustable varying speed is required.

Three phase induction motors are used for high power applications such as in industries.

Single-phase motors are used in most homes, offices and rural areas.

Fractional kilowatt motors are used in fans, refrigerators, mixers, vacuum cleaners, washing machines, and small farming appliances.

Shaded pole motors are used in small fans, convectors, vending machines, photocopying machines, advertising displays.

Synchronous motors – power factor improvement- the power factor of the motor can be controlled over a wide range by adjusting its excitation. Since it can be operated under a wide range of power factors both lagging and leading by its field current it is used in power factor improvement.

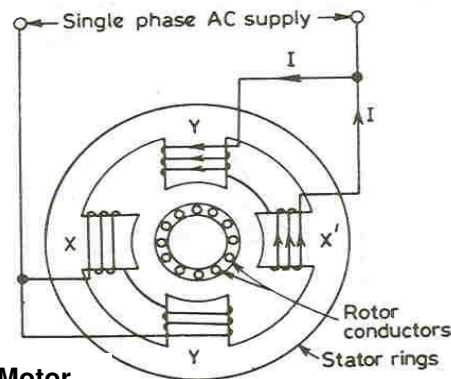
Q.39 Explain, the construction, working principle & applications of a single-phase induction motor. (8)

Ans:

Working : Construction of a single -phase induction motor is similar to that of a three - phase induction motor except that the stator is provided with a single- phase winding. Thus, it has a stator with slots, and squirrel cage rotor with a small air-gap in between.

When it is connected to single- phase ac supply, alternating current flows in its stator winding and the polarity of stator poles would alternately be N and S. The field so produced will be pulsating i.e. polarities will be alternating with the flux rising and falling in strength. The current induced in the rotor will tend to turn it in both directions alternately and thus the rotor will be at standstill due to inertia. If rotor is given a push by hand or by another means in any direction, it will rotate in the same direction developing operating torque. Thus a single –phase induction is not self- starting and requires special starting means.

Applications: Due to their relatively simple construction, availability in variety of designs, and characteristics and promoted by economics as well as meeting the special requirements, single-phase induction motors are widely used, particularly where fractional horse power range is less than 2 H.P. For example motors in 1/8 to 3/4 H.P. ranges are used in fans, refrigerators, washing machines, blowers, centrifugal pumps, 1/30 to 1/20 H.P. range, are used in toys, hair dryers, vending machines, etc.



Single Phase Induction Motor

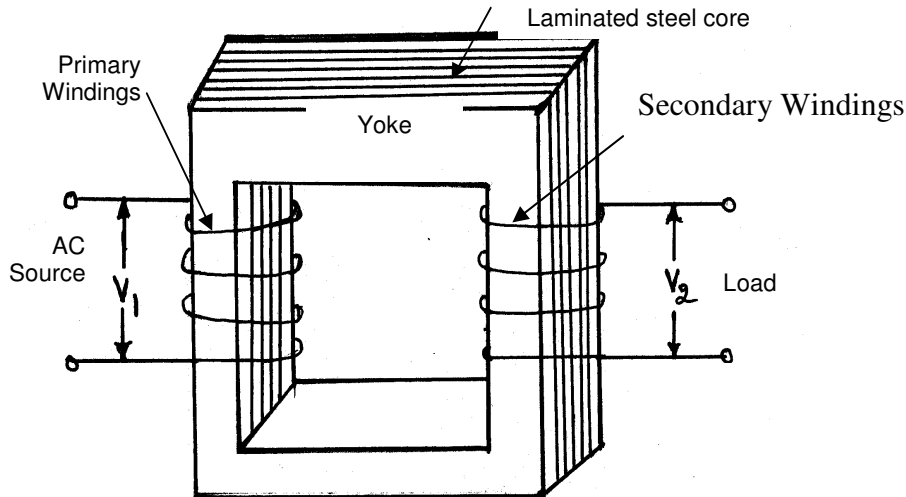
Q.40 Explain the basic construction and working principle of a single –phase transformer.

(8)

Ans:

Basic Construction and Working Principle of a single – phase Transformer: A transformer consists of a soft iron or silicon steel core and two windings placed on it. The windings are insulated from both the core and each other. The core is built up of thin soft iron or silicon steel laminations to provide a path of low reluctance to the magnetic flux. The winding connected to the supply mains is called the primary and that connected to the load circuit is called the secondary. When the primary winding is connected to an ac supply mains, current flows through it. Since this winding links with an iron core, so current flowing through this winding produces an alternating flux in the core. Since this flux is alternating and links with secondary winding also, it induces an emf in the secondary winding. The frequency of induced emf in the secondary winding is the same as that of the flux or that of the supply voltage. The induced emf in the secondary winding enables it to deliver current to an external load connected across it. Thus the energy is transformed from primary winding to the secondary winding by means of electro-magnetic induction without any change in frequency. The flux of the iron core not only links with the secondary

winding but also with the primary winding, so produces self-induced emf in the primary winding. This induced emf in the primary winding opposes the applied voltage and therefore, sometimes it is known as back emf of primary.



- Q.41** How does the three – phase transformer differ from a single – phase one. Give advantages and disadvantages of a 3 – phase transformer. (8)

Ans:

Three, single - phase transformers have each a primary winding upon one leg. These transformers are symmetrically wound and each winding is connected to one wire of a 3 - phase system. The three cores are placed 120° apart so that the empty legs of the three are in contact. The centre leg formed by these three carries the sum of the three flux produced by the three phase currents. Since the sum of the three currents at any instant is zero, the sum of the three fluxes must also be zero. Any two legs act as the return for third, just as in a 3- phase system any two wire act as the return for the current in third wire. Like single phase transformers 3 - phase transformers are also of core and shell type.

Advantages – 3 – Phase transformers have considerably less weight, occupy less floor space and cost less than 3 single phase transformers of equal rating.

Disadvantages – If one of the phase becomes defective, then whole of transformer is to be replaced, but in case of 3 - single phase transformers, if one of the transformer becomes defective, the system can still be run open delta at reduced capacity or the defective transformer can be replaced by a single spare.

- Q.42** Explain DC series, shunt and compound motors and their speed torque characteristics. (8)

Ans:

Types of D.C. Motors:

Series – wound motor possesses the field winding of a few turns of heavy conductor, connected in series with the armature, i.e. load current flows through both the field and armature. With increasing load, the speed decreases. Consequently, at no-load, the speed of the motor is very high. Hence, series-wound motor should never be used without load. Such motors are used in cranes, pumps, trains, trolleys, etc. due to its very high starting torque.

Fig (a).

Shunt – wound motor possesses the field winding of large number of turns, and high resistance, which is connected in parallel with the armature. Its starting torque is about 2.5 to 3 times greater than the full-torque. By using shunt regulator the variations of speed of the motor can be achieved. It runs practically at constant speed at almost all loads. Such motors are used in lathes, drills, printing press and for driving pumps. Fig.(b)

Compound – wound motor has series as well shunt windings. Depending upon the type of field connections, a compound motor can be one in which series field assists the shunt field windings. With heavy starting loads, the torque increases. As the load increases, the speed decreases, and vice-versa, similar to series motor. However, when the load is suddenly decreased, the shunt prevents the motor from speeding beyond safe limits. Such motors are used in machine tools, coal cutting machines, punch presser, crushers, compressor, etc. Fig (c)

Differential compound motor is one in which the field due to series winding opposes that due to shunt- winding. Its speed remains constant. However, when such a motor is started, the series winding requires to be short- circuited; otherwise the series winding would rise to its full-value before the shunt field does so. If the series winding is not short circuited at the time of starting, motor starts with high speed, and that too in wrong direction. Such motors are rarely used since ordinary shunt motor serves the purpose of providing constant speed.

Fig. (d)

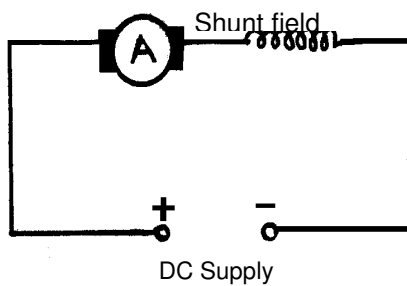


Fig. (a)

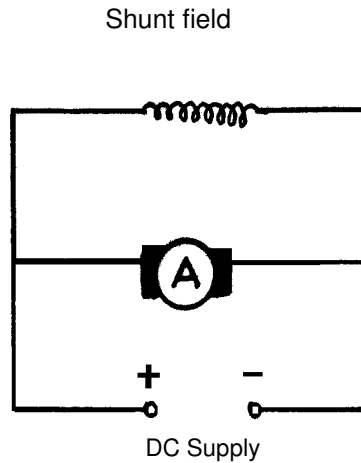


Fig. (b)

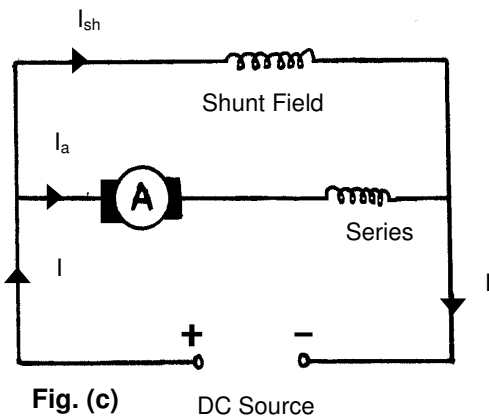


Fig. (c)

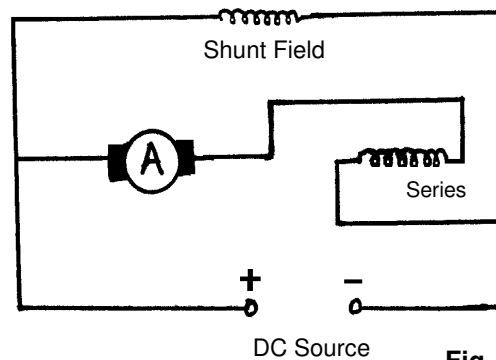
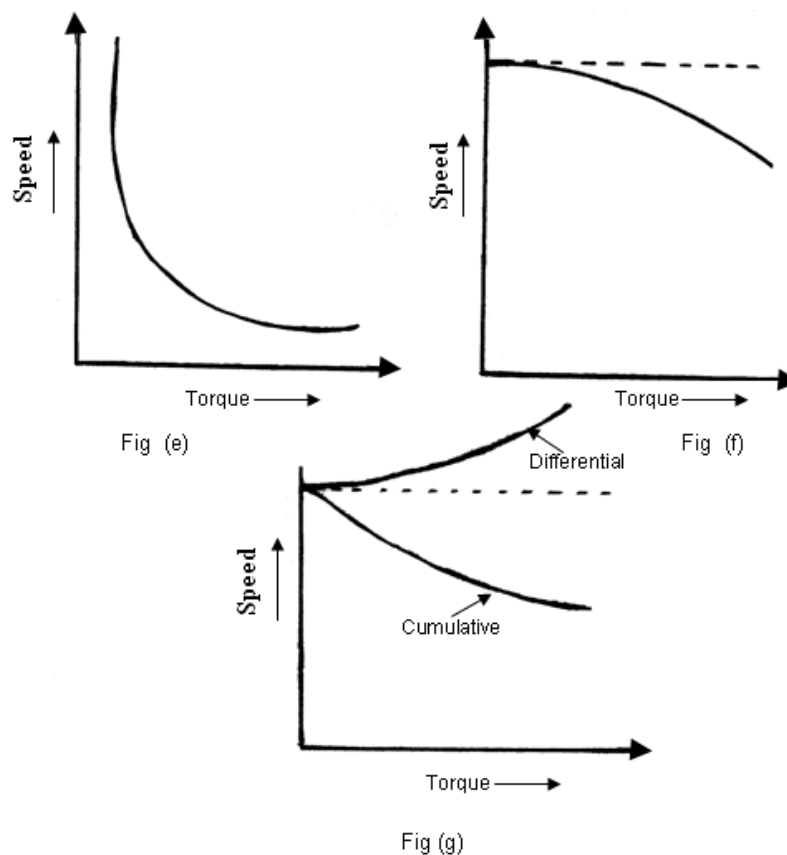


Fig. (d)

Speed–torque characteristics: Series Motor: Since a series motor develops a high initial torque at low speeds; and a low torque at high speed, so speed-torque characteristic of a series motor is hyperbola. High initial torque at low speeds enables even a small series motor to start a heavy load. However when starting friction is overcome the motor begins to accelerate, counter emf increases, current and torque decreases correspondingly as the motor speeds up. Fig. (e)

Shunt Motor: The speed – torque characteristics is similar to speed-armature current characteristics. The flux is independent of load and remains constant. As the back emf is also practically constant, speed is a constant. But strictly speaking both back emf and flux decrease with increasing load. However the back emf decreases slightly more than flux so that on the whole there some decrease in speed. Hence, the torque curve is slightly drooping. Fig. (f)

Compound motors: Speed –Torque characteristic depends on the type of compound motor. In a cumulative compound motor Fig.(g), the series excitation helps the shunt excitation. So, its speed- torque characteristic lies between that of shunt- motor and series motor. In a differential compound motor Fig.(g)the torque increases very slightly with speed.



- Q.43** Define the following:
- (i) Average demand
 - (ii) Maximum demand
 - (iii) Demand factor.
 - (iv) Load factor.

(8)

Ans:

i) Average Demand

By average demand of an installation is meant its average power requirement during some specified period of time of considerable duration such as a day or month or year giving a daily or monthly or yearly average power respectively.

$$\text{Average Power} = \frac{\text{kwh Consumed in the period}}{\text{hours in the period}}$$

ii) Maximum Demand

The maximum demand of an installation is defined as the greatest of all the demand which have occurred during a given period.

It is measured accordingly to specifications, over a prescribed time interval during a certain period such as day, a month or a year.

iii) Demand Factor

It is defined as the ratio of actual maximum demand made by the load to the rating of the connected load.

$$\text{Demand factor} = \frac{\text{Maximum demand}}{\text{Connected load}}$$

iv) Load Factor

It is defined as the ratio of the average power to the maximum demand. It is necessary that in each case the time interval over which the maximum demand is based and the period over which the power is average must be definitely specified.

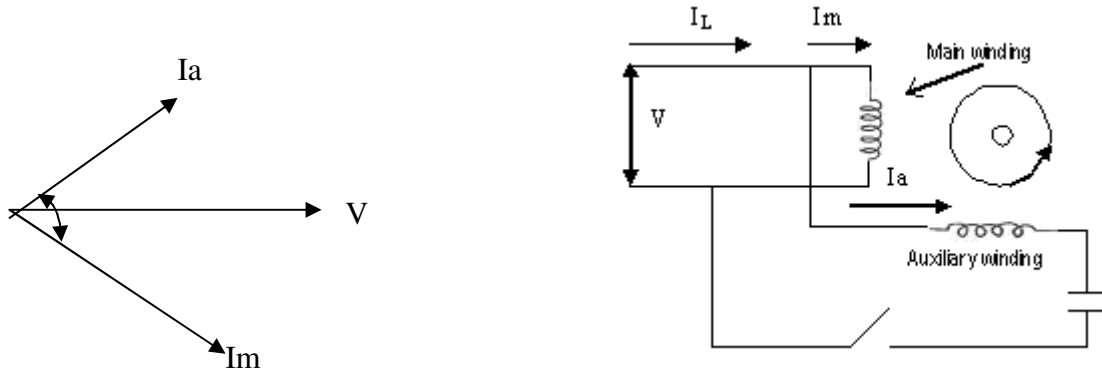
When applied to a generating station annual load factor is

$$= \frac{\text{No. of units actually supplied / year}}{\text{Maximum possible no. of units that can be supplied}}$$

Q.44 Explain the working of a capacitor-start and capacitor-start and-run single-phase induction motors with suitable diagrams. **(8)**

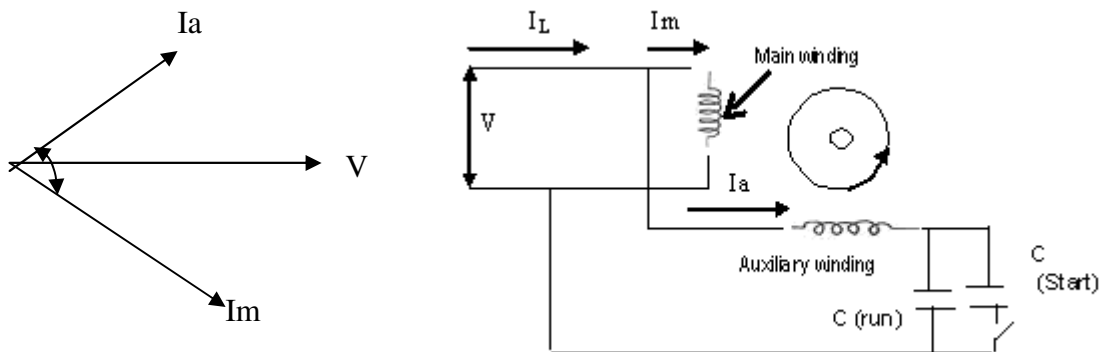
Ans:

Capacitor – start motor – For obtaining the necessary phase difference in the currents of the two windings a capacitor is placed in series with the auxiliary winding. While the main winding draws a lagging current I_m the current in the auxiliary winding I_a is leading and it is possible to make the phase difference between them 90° at start. During running the auxiliary winding is cut out so the capacitor is only short – time rated. Such a motor is known as Capacitor – start motor.

DE05
DE06ELECTRICAL ENGINEERING
BASIC ELECTRONICS

Capacitor – start motor

Capacitor start and run single phase induction motor: The connection diagram is as shown in the fig. A larger capacitance (C (run)) and C(start in parallel) is employed to provide best starting conditions. The phase separation is adjusted to more than 90°. The C (start) is cut out at a certain speed leaving C (run) in circuit to give best running performance. C (run) also helps to improve the overall pf of the motor. While C (run) is continuous rated, C (start) need only the short time rated. This motor is employed for hard to start loads.



Capacitor start and run single - phase induction motor

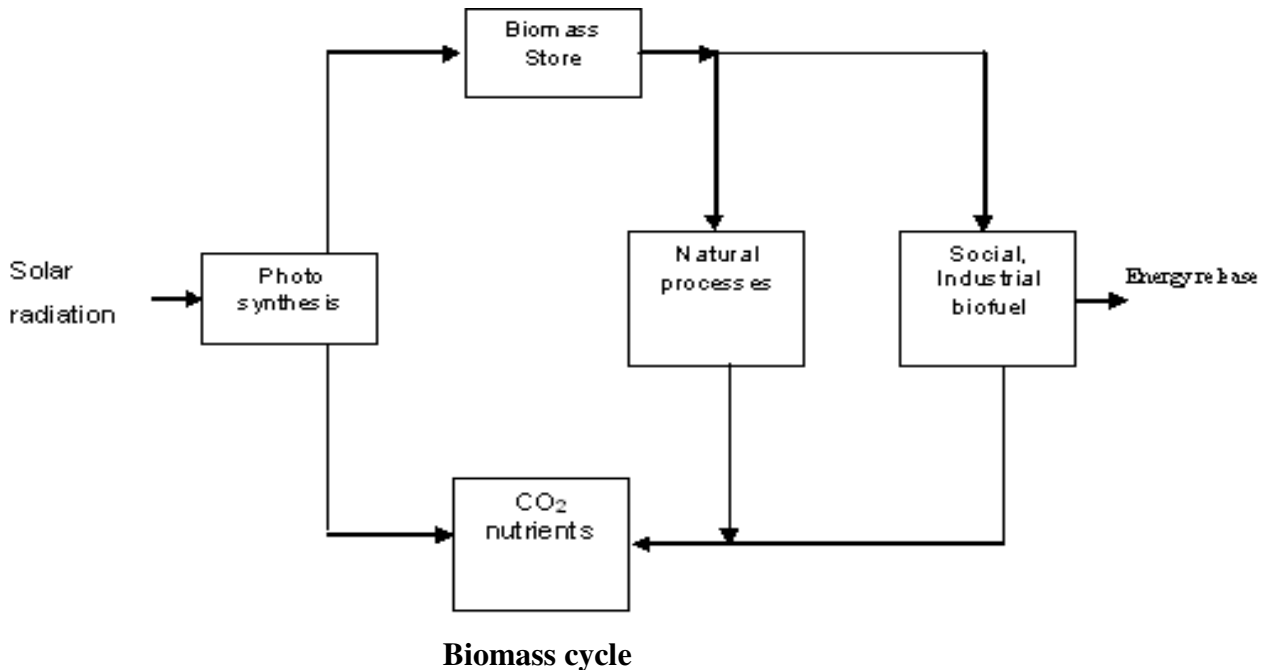
Q.45 Explain, how Biofuels can be used to produce electricity. Also draw the biomass cycle. (8)

Ans:

Biomass is the material of all plants and animals. The organic carbon part of this material reacts with oxygen in combustion and in the natural metabolic processes. The end product of these processes is mainly CO₂ and heat. This biomass can be transformed by chemical and biological processes into intermediate products (biofuels) like methane gas, ethanol liquid or charcoal solid that are used in agro industries, which may be nonpolluting.

Biofuels can be used to produce electricity in two ways; - By burning in furnace to produce steam to drive turbines or by allowing fermentation in land fill sites or in special anaerobic tanks, both of which produce methane gas which is used as fuel for household stoves and in spark ignition engines or gas turbines. The carbon di-oxide produced in this process may be recycled by cultivating crops or planting trees as CO₂ is absorbed during photosynthesis by

plants. Biofuels have a potential to meet about 5 per cent of the electricity requirement of an industrialized country by exploiting all forms of the household and industrial waste, agricultural waste etc.



Q.46 Explain the construction of a lead acid battery and give the equations during the charging and discharging process. (8)

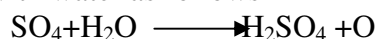
Ans:

The most common type of secondary cell used is Lead - acid Accumulator. The electrolyte is a solution of sulphuric acid (H_2SO_4) and pure water, and the electrodes are made from lead.

Initial Charging: The lead acid cell fundamentally has two electrodes made of pure lead. For charging purposes, the device is connected across a source of D.C. supply having a voltage approximately 3 volts. When the circuit is switched on, the current flows inside the cell through ions and outside the cell through electrons. The acid molecules break into negative ions represented by (SO_4^-) and positive ions given by (H^+) which are two in number against each negative ion. or $H_2SO_4 \longrightarrow (SO_4^-) + 2 (H^+)$

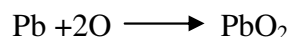
Each negative ion has two extra electrons and each positive ion is short of one electron. The negative ions go towards the positive electrode and vice versa.

Each negative ion transfers two electrons to the external circuit after coming in contact with the positive electrode. The ion becomes radical after departing with its extra electrons. It now reacts with water as follows

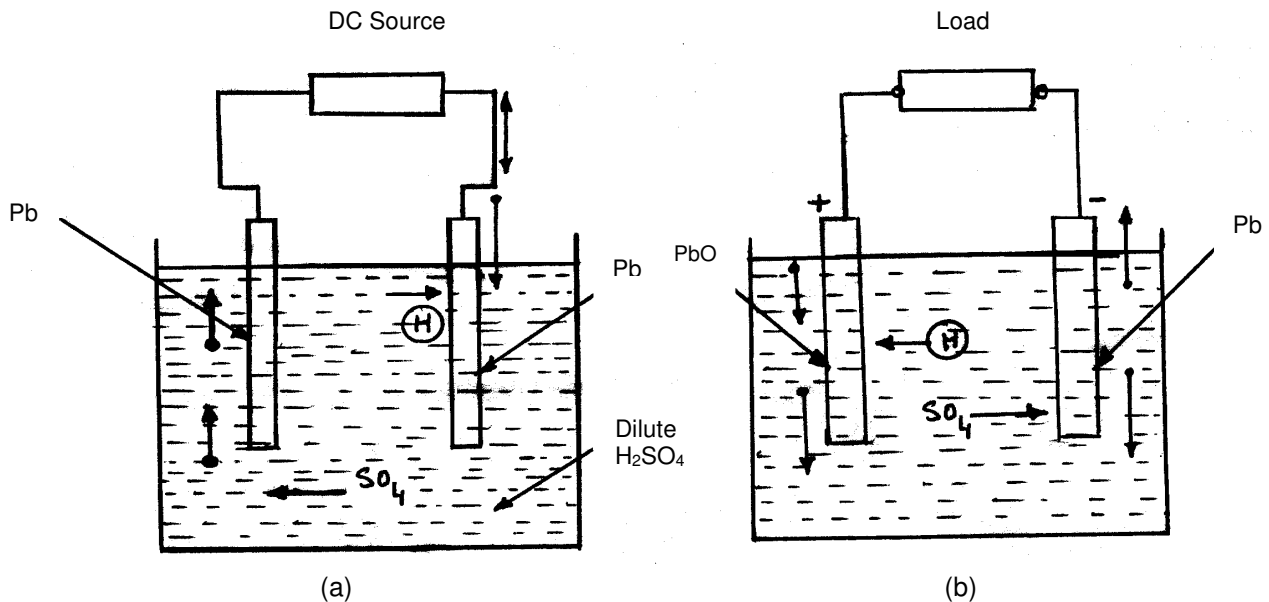


Which shows formation of sulphuric acid and nascent oxygen.

Two such oxygen atoms react with lead of the positive electrode of anode forming lead peroxide on the surface of the electrode.



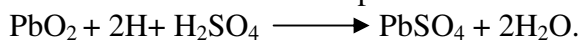
As the charging proceeds a layer of brown coloured lead peroxide is formed on the positive plate. The electron supplied by the negative ions reach the negative plate / electrode of cathode through the charging circuit. The H^+ ions move towards the cathode and receive one electron each, when coming in contact with the electrode. These ions become hydrogen atoms. Two such atoms combine together to form Hydrogen molecules, which escape into the atmosphere. Thus during **charging**: Lead peroxide is coated on the positive electrode. Density or specific gravity of the electrolyte improves due to formation of H_2SO_4 . Hydrogen escapes from the negative electrode, which remains pure lead during the process of charging. The electrodes show a potential difference, which reaches a value of 2.6 to 2.7 volts when across the charger.



It goes to 2.1 volts when removed from the charger. The larger potential difference is due to various ions in contact with electrodes, and the indication given by the voltmeter does not give the true voltage or emf developed across the electrode if measured by keeping the charger circuit on.

Discharging : For this, the charged cell is connected across some load. This can be a small resistance as shown in fig (b). Since, the direction of current through the cell is reversed during discharging the negative ions go towards the negative electrode and vice versa. This is opposite to the movement of ions during charging. After passing on two electrons to the external circuit, the negative ions become SO_4 radical, which reacts with lead of negative electrode so that $Pb + SO_4 \longrightarrow PbSO_4$ or the negative electrode is coated with a layer of white coloured lead sulphate.

On the other hand the H^+ ions receive electrons from the external circuit to become hydrogen atoms. The reaction on the positive electrode is as follows:



Thus during discharging both the electrodes are coated with $PbSO_4$ coating which is whitish in colour, formation of water results in fall in specific gravity of the electrolyte.

Q.47 Give constructional details of ceramic, mica, film and electrolytic capacitors. Give their typical applications. (7)

Ans:

Mica: Mica is a transparent, high dielectric strength mineral that is easily formed into uniform sheets as thin as 0.0025mm.

Mica-capacitors are built in round, rectangular or irregular-shapes. They are constructed by sandwiching layers of metal foil and mica. Some times silver is deposited in lieu of metal foil and encapsulated in a plastic-package.

Applications:

- 1) Used as a precision capacitors.
- 2) Employed in high-frequency applications such as oscillator tuning and filter construction.

Ceramic: Ceramic capacitors are quite suitable for generation of large-powers at radio frequencies. The ceramic is a dielectric material made from earth fired under extreme heat. Titanium oxide or several other types of silicates are used to obtain very high value of dielectric constant of ceramic material.

Applications:

- 1) Primarily used as COUPLING and Bypass portions of radio-frequency circuits.
- 2) Specially designed ceramic-capacitors are employed in resonant circuits.

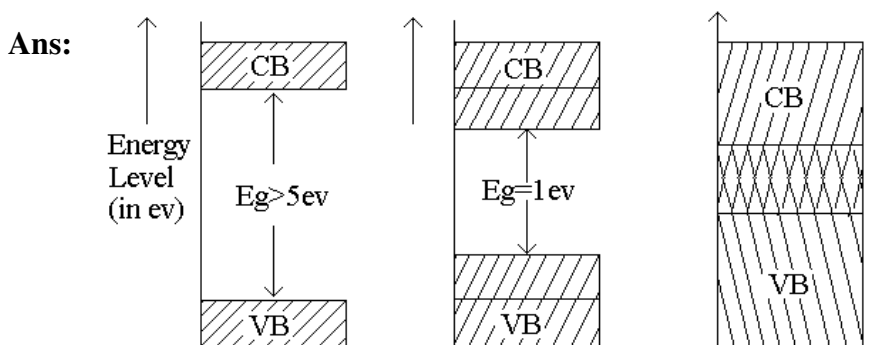
Film: Plastic-film capacitors are constructed by a thin-sheet of plastic (such as Mylar, Teflon, or Polyethylene) is employed as dielectric. Thus dielectric improves the properties of the capacitor by minimizing leakage currents.

Applications: Used for both dc and ac circuits.

Electrolytic: Electrolytic capacitors are usually made of aluminium or tantalum because they form oxides with very high dielectric-strengths. Electrolytic capacitors should only be connected in a circuit with the proper polarities.

Applications: 1) Used in ac-circuits.

Q.48 Differentiate between an insulator, a semi-conductor and a good conductor. How can we make an intrinsic material to improve conduction necessary for use in BJTs. (7)



(a) For Insulator

(b) For Semiconductor

(c) For Conductor

In case of insulators, there is practically no electron in the conduction band, and valence band is filled. For an insulator, the valence band and conduction bands are so apart.

For semiconductors at a temperature of absolute zero the valence band is usually full and there may be no-electron in the conduction band. However both the bands are so close that electron can be lifted from the valence band to the conduction band by imparting some energy to it. This energy must be more than energy gap E_G .

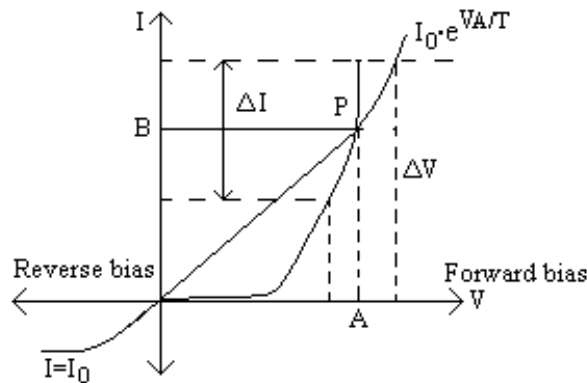
In case of conducting materials there is no forbidden gap, and valence and conduction bands overlap. The orbits in the conduction band are very-large.

When the material is heated, electrons break away from their atoms and move from the valence band to conduction-band. This produces holes in the valence band and free-electrons in conduction-band. Conduction can then occur by electron movement and by hole-transfer with the increase in temperature, the rate of generation of electron-hole pairs is increased. Thus in turn increases the rate-of recombination.

When the semiconductor is illuminated, its resistance decreases in the same way as in case of increase in temperature. The forbidden energy gap E_G also depends somewhat on temperature.

- Q.49** For a p n junction diode, draw a typical V-I characteristic. What is meant by
- forward resistance
 - static resistance
 - dynamic resistance of a diode.

(7)

Ans:

VI Characteristics of Diode

Forward Resistance: The resistance offered by a diode in the circuit, when forward biased, is known as the forward-resistance. Thus resistance is not the same for dc as well as changing-current.

DC or Static Resistance: R is the resistance offered by a diode to the direct-current. It is simply the ratio of the dc-voltage across the diode to the direct-current flowing through it. At any point P on the V-I characteristic of the diode, the voltage across the diode is OA and corresponding current is OB .

So dc or static resistance, $R = \frac{V}{I} = \frac{OA}{OB}$

Thus at any point on the V-I characteristic of the diode, the dc or static resistance R is equal to the reciprocal of the slope of the line joining the operating point to the origin.

AC or Dynamic Resistance: r is a resistance offered by a diode to the changing forward-current. It may also be defined as the reciprocal of the slope of the forward characteristic of the diode.

$$r = \frac{dv}{dI} = \frac{\eta V_T}{I_o \cdot e^{V/\eta V_T}} = \frac{\eta V_T}{I + I_o}$$

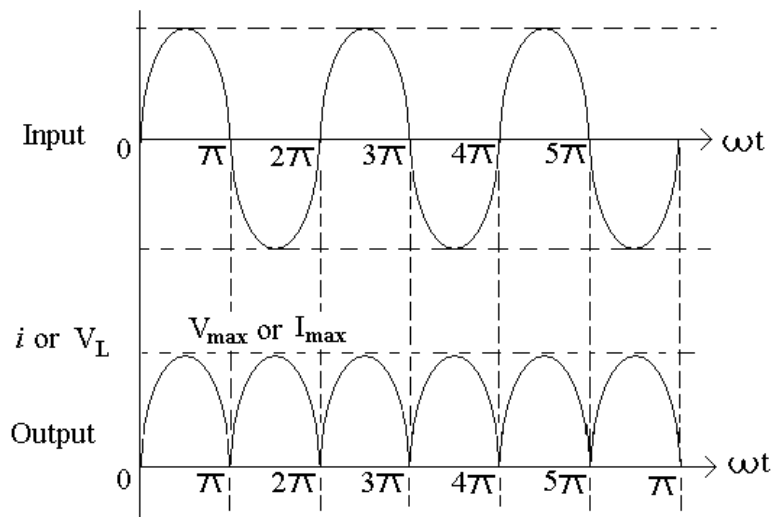
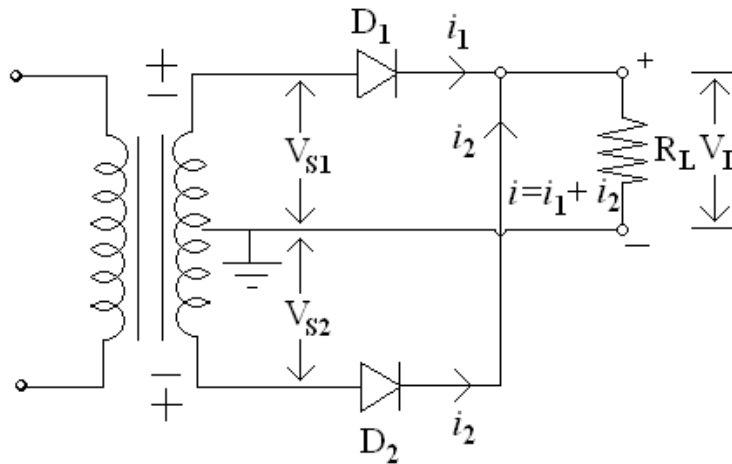
For $\left| \frac{V}{\eta V_T} \right| \gg 1$, then

$$r = \frac{\eta V_T}{I}$$

Q.50 With the help of neat diagram, explain the functioning of a full-wave rectifier. Clearly explain the importance of

- (i) PIV
- (ii) Ripple factor
- (iii) Voltage regulation
- (iv) Capacitor filter in the context of a full-wave rectifier with centre tapped transformer. (14)

Ans:



When the top of the transformer secondary winding is positive the anode of diode D_1 is positive w.r.t cathode, and anode of diode D_2 is negative w.r.t cathode. Thus only diode D_1 conducts, being forward biased and current flows from cathode to anode of diode D_1 , through load resistance R_L and top half the transformer secondary making cathode end of load resistance R_L positive. During the secondary half-cycle of input voltage the polarity is reversed, making the bottom of the secondary winding positive w.r.t centre top and thus diode D_2 is forward biased and diode D_1 is reverse biased.

(i) **PIV(Peak Inverse Voltage)**: It is the maximum possible-voltage across a diode when it is reverse-biased.

$$\text{PIV of diode, } D_2 = V_{S_{\max}} + V_{S_{\max}} = 2V_{S_{\max}}$$

$$\text{PIV of diode, } D_1 = 2V_{S_{\max}}$$

(ii) **Ripple Factor**:

$$K_f = \frac{I_{rms}}{I_{av}} = \frac{I_{\max} / \sqrt{2}}{2I_{\max} / \pi} = \frac{\pi}{2\sqrt{2}} = 1.11$$

(iii) **Voltage Regulation**:

$$\begin{aligned} V_{dc} &= \frac{2}{\pi} I_{\max} \cdot R_L = \frac{2V_{S_{\max}} \cdot R_L}{\pi(R_F + R_L)} \\ &= \frac{2V_{S_{\max}}}{\pi} \left[1 - \frac{R_F}{R_F + R_L} \right] = \frac{2V_{S_{\max}}}{\pi} - I_{dc} R_F \\ V_{dc} &= \frac{2V_{S_{\max}}}{\pi} - 2I_{dc} R_F \end{aligned}$$

(iv) **Capacitor filter in context of transformer :**

$$\gamma = \sqrt{K_f^2 - 1} = \sqrt{(1.11)^2 - 1} = 0.482.$$

Q.51 Explain the Zener phenomenon. How does it differ from Avalanche breakdown? (7)

Ans:

Under a very high-reverse voltage, the depletion region expands and the potential barrier increases leading to a very high electric field across the junction. The electric-field will break some of the covalent-bonds of the semiconductor atoms leading to a large number of free minority carriers, which suddenly increase the reverse current. This is also called the **Zener-Effect**.

Zener-breakdown or Avalanche breakdown may occur independently or both of these may occur simultaneously. Diode junctions that breakdown below 5v are caused by Zener Effect. Junctions that experience breakdown above 5v are caused by avalanche-effect.

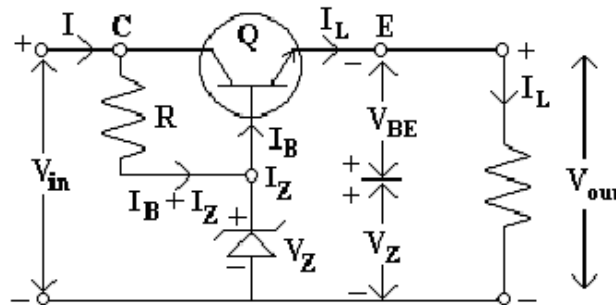
The Zener-breakdown occurs in heavily doped junctions which produce narrow depletion layers. The avalanche breakdown occurs in lightly doped junctions, which produce wide depletion layers.

Q.52 Why do we require Voltage Regulators? Explain in detail the working of a DC series Voltage Regulator. Clearly explain the functions of series-pass transistor, current limiter and error amplifier of such a Voltage Regulator. (10)

Ans:

The primary function of a voltage-regulator is to maintain a constant dc-output voltage. However, it also rejects ac-ripple voltage that is not removed by the filter. The regulator may also include protective functions such as short-circuit protection, current limiting, thermal shut down, or over-voltage protection.

Transistor-series voltage regulator:



Thus circuit is a series-regulator because collector and emitter-terminals of the transistor are in series with the load.

Series-pass transistor: In the above circuit, the transistor Q is termed a series-pass transistor. The series element controls the magnitude of the input-voltage that gets to the output.

Current limiter: If the load resistance R_L is reduced or load-terminals are shorted accidentally, a very large load current will flow in the circuit. It may destroy the pass-transistor Q_1 , diode or possibly some other component. To avoid this situation, a current limiting circuit is added to a series regulator.

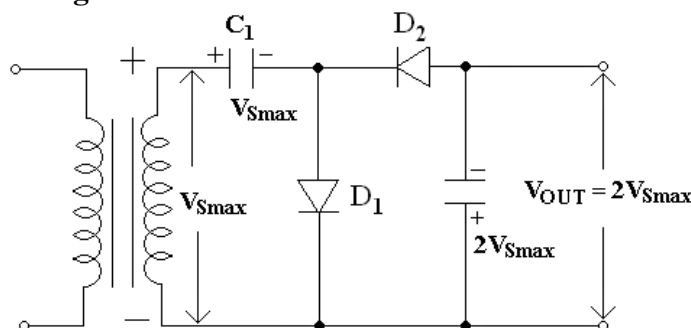
Error Amplifier: The error amplifier is used to maintain a constant-voltage through a negative feedback. The internal voltage reference is tightly controlled during the fabrication of IC.

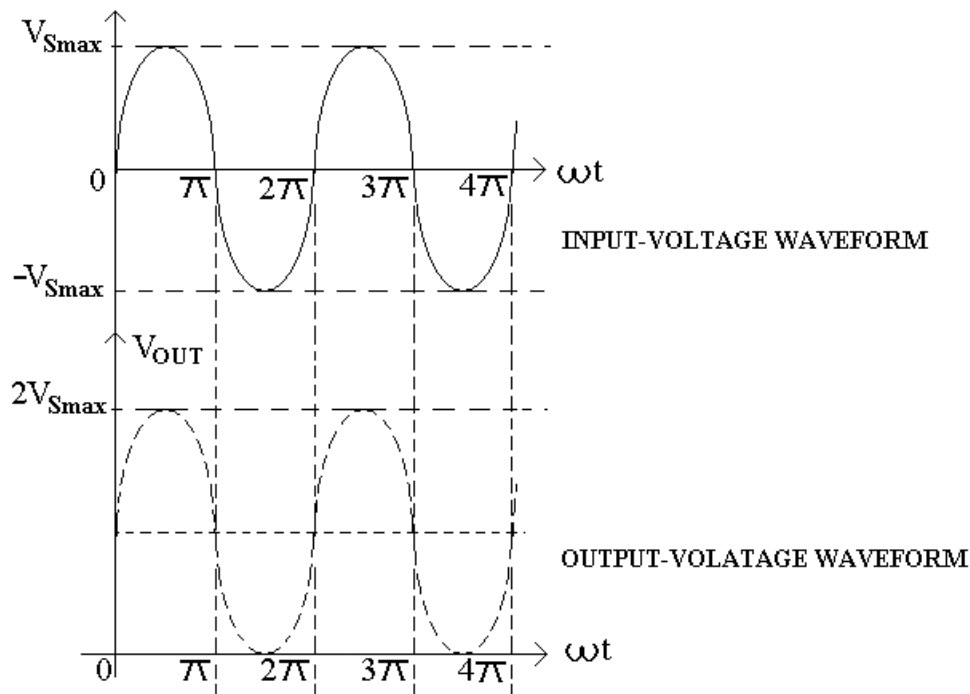
Q.53 With the help of neat diagram explain the working of a Voltage Doubler. (4)

Ans:

Voltage-multiplier is a modified-capacitor filter circuit that delivers a dc-voltage twice or more times of the peak value (Amplitude) of the input ac-voltage. Such power supplies are used for high-voltage and low-current devices such as cathode-ray-tubes.

Half-wave voltage doubler:





During the positive half-cycle of the ac-input voltage, diode D_1 being forward biased conducts and charges C_1 upto peak value of secondary voltage $V_{S_{max}}$. During the negative half-cycle of the input voltage diode D_2 gets forward-biased and conducts charging capacitor C_2 .

Applying Kirchoff's- voltage law to the outer loop we have

$$-V_{S_{max}} - V_{C_1} + V_{C_2} = 0$$

$$\text{Or } V_{C_2} = V_{S_{max}} + V_{C_1} = V_{S_{max}} + V_{S_{max}}$$

$$= 2V_{S_{max}}$$

= Twice the peak value of the transformer secondary voltage.

Q.54 Explain the functioning of a bipolar junction transistor. What is the

- relation between α and β (3)
- effect of variation of V_{CC} on the collector current (4)
- method of biasing the BJT (3)
- selection of proper Q-point for linear operation of a BJT amplifier. (4)

Ans:

Operation of transistor: For normal operation the emitter-base junction is always forward biased while the collector-base junction is always reverse-biased.

The forward bias at the emitter-base junction reduces the barrier potential and narrows the depletion region. However, the relatively light doped base and collector-regions produce a wide depletion region under the reverse-bias. Thus the effective base width W_b between the two depletion regions is very narrow.

Electrons are injected into the emitter region by the emitter bias supply V_{EB} . These conduction band electrons have enough energy to overcome the emitter-base barrier

potential. The injected electrons enter the very thin, lightly doped base region. Because the base is very lightly doped relative to the emitter region, only a few of the electrons recombine with the holes doped into the base.

Injected electrons diffuse into collector region due to extremely small thickness of base which is much less than the diffusion length. Most of the electrons cross into the collector-region. Collector is reverse-biased and creates a strong electro-static field between base and collector. The field immediately collects the diffused-electrons which enter the collector junction.

(a) The relation between α and β :

$$\beta = \frac{\Delta I_C}{\Delta I_B} \text{ and } \alpha = \frac{\Delta I_C}{\Delta I_E} = \frac{\Delta I_C}{\Delta I_C + \Delta I_B}$$

$$\therefore \frac{1}{\alpha} = \frac{\Delta I_C + \Delta I_B}{\Delta I_C} = 1 + \frac{\Delta I_B}{\Delta I_C} = 1 + \frac{1}{\beta}$$

$$\therefore \alpha = \frac{\beta}{\beta + 1}$$

(b) Effect of variation of V_{CC} on the collector current:

- The collector current I_C varies with V_{CB} or V_{CC} only for very low-voltage but transistor is never operated in this region.
- In active-region collector current I_C is almost equal to I_E and appear to remain constant when V_{CB} is increased.
- The increase in V_{CB} , it conducts better, although the effect is not very significant. This is because large reverse-bias voltages causes the depletion layer at the collector-base junction to penetrate deeper into the base of the transistor, thus reducing the distance and the resistance between the emitter-base and collector-base regions.

(c) Method of biasing the BJT:

There is a large number of circuits for biasing of a transistor. These circuits differ so as to their ability to keep the quiescent point fixed in spite of variations in transistor characteristics and also effects of temperature variations and ageing.

A Biasing network associated with a transistor should fulfil the following requirements:

- (1) Establish the operating point in the middle of the active region of the characteristics, so that on applying the input-signal the instantaneous operating does not move either to the saturation region, even at the extreme values of the input signal.
- (2) Stabilize the collector-current I_C against temperature variations.
- (3) Make the operating point independent of transistor parameters so that replacement of transistor by another of the same type in the circuit does not shift the operating point.

(d) Methods of different biasing:

1. Simplest Biasing Circuit,
2. Fixed bias circuit
3. Self-bias or Emitter Bias
4. Potential-divider bias.
5. Collector-to-base bias.

Q.55 In the cases of CE and CC configurations of BJT amplifiers, compare:

- (i) their input and output impedances. (3)
- (ii) their Voltage gains and Current gains. (7)

(iii) their typical uses-give two uses of each case. (4)

Ans:

Configuration	Common Emitter	Common Collector
Characteristics		
Input Impedance	Medium ($\approx 800\Omega$)	Very high ($\approx 750K\Omega$)
Output Impedance	High ($\approx 50K\Omega$)	Low ($\approx 50\Omega$)
Current Gain	High (≈ 80)	High ($\approx 100\Omega$)
Voltage Gain	About 500	Less than unity

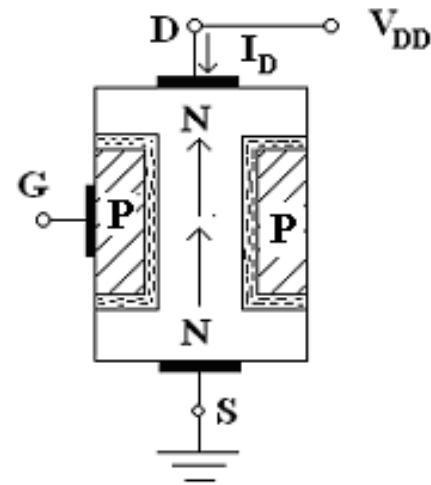
Applications: CE – For AF-applications.
CC – For impedance matching.

Q.56 Explain the principle of operation of Field Effect Transistors (FET). How does a JFET and a MOSFET differ in operation? Define the FET parameters g_m , r_d & μ . Show that $\mu = g_m r_d$. (7)

Ans:

Operation: let us consider an N-channel JFET for discussing its operation

- I. When neither any bias is applied to the gate nor any voltage to the drain w.r.t source (i.e. when $V_{D_S} = 0$), the depletion regions around the P-N junctions are of equal thickness and symmetrical.
- II. When positive voltage is applied to the drain terminal D w.r.t source terminal S without connecting gate-terminal G to supply, the electrons flow from terminal S to terminal D whereas conventional drain-current I_D flows through the channel from D to S.



Comparison of JFET's and MOSFET's

- I. JFET's can only be operated in the depletion mode whereas MOSFET's can be operated in either depletion or in enhancement mode. In a JFET, if the gate is forward-biased, excess-carrier injection occurs and the gate-current is substantial.
- II. MOSFET's have input impedance much higher than that of JFET's. Thus is due to negligible small leakage current.
- III. JFET's have characteristic curves more flatter than those of MOSFET's indicating a higher drain resistance.
- IV. When JFET is operated with a reverse-bias on the junction, the gate-current I_G is larger than it would be in a comparable MOSFET.

Amplification factor, $\mu = \frac{\Delta V_{DS}}{\Delta V_{GS}}$ at constant I_D .

$$\mu = \frac{\Delta V_{DS}}{\Delta I_D} \times \frac{\Delta I_D}{\Delta V_{GS}}$$

$$= r_d \times g_m = \text{a.c. drain resistance} \times \text{transconductance.}$$

Amplification factor μ of a JFET may be as high as 100.

- Q.57** How can we use FET
- (i) as an Amplifier.
 - (ii) as a Switch.

(7)

Ans:

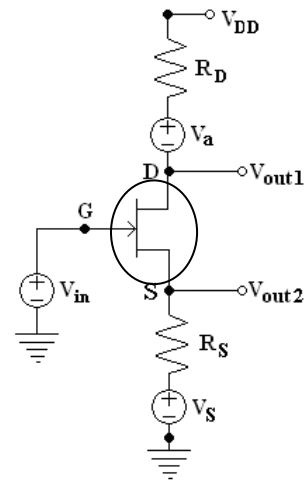
FET Amplifier:

The circuit consists of a three independent signal sources (i.e. V_{in}, V_a, V_S). For a common-source amplifier $V_a = V_S = 0$, and the output V_{OUT1} is taken at the drain terminal D.

For common-gate circuit $V_{in} = V_a = 0$, the input-signal voltage is V_S with source resistance R_S , and the output V_{OUT1} is again taken at drain terminal D.

For common-drain (or source follower)

$R_D = 0, V_S = V_a = 0$, the input-signal voltage is V_{in} and the output V_{OUT2} is taken at the-source terminal.



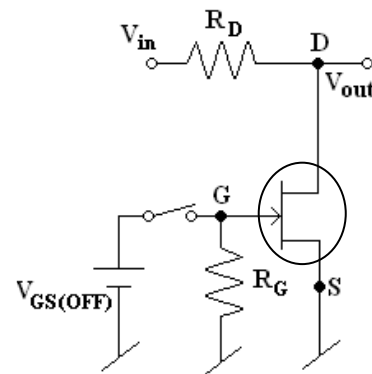
As a Switch:

When no gate-voltage is applied to the FET i.e. $V_{GS} = 0$, FET – becomes saturated and it behaves like a small-resistance usually of the value less than 100Ω and, therefore, output-voltage becomes equal to

$$V_{out} = \frac{R_{DS}}{R_D + R_{DS(ON)}} \cdot V_{in}$$

Since R_{DS} is very large in comparison to $R_{DS(ON)}$, so V_{out} can be taken equal to zero.

When a negative-voltage equal to $V_{GS(OFF)}$ is applied to gate, the FET operates in the cut-off region and it acts like a very high resistance usually of some mega-ohm's. Hence output voltage becomes nearly equal to input-voltage.



- Q.58** Describe in detail the construction of a triode. To what use a triode may be put? How does it differ from a BJT? (7)

Ans:

Construction: It consists of three electrodes namely cathode, anode and control grid. The cathode is located at the centre of the tube and is surrounded by the control-grid which in turn is surrounded by the anode (or plate). The grid is nearer to the cathode than to plate. The control-grid has a mesh-structure so that electrons emitted by the cathode can pass through it. The whole assembly of heater filament, cathode, grid and plate is placed inside an evacuated glass envelope. The connections for grid, plate, and cathode and heater filament are usually brought-out at the base of the tube.

Applications:

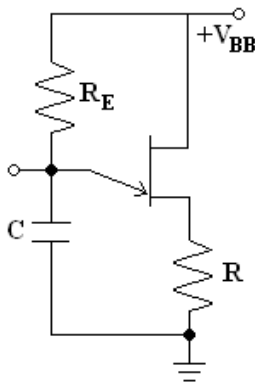
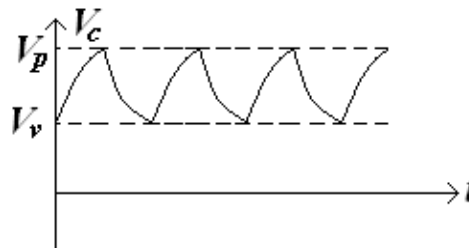
1. As an amplifier.
2. Detectors and oscillators at audio or radio frequencies.

The main difference between BJT and vacuum triode is that the transistor is a current-controlled device where as vacuum triode is a voltage-controlled device.

Q.59 Give three uses of a Unijunction Transistor (UJT). Explain one use in detail. (7)

Ans:

UJT can be used in variety of applications. A few include oscillators, pulse-generators, saw-tooth generators, triggering circuits, phase control, timing circuits, and voltage-or current-regulated-suppliers.

UJT Relaxation Oscillator:**Basic Circuit****Out-put voltage wave-form across C**

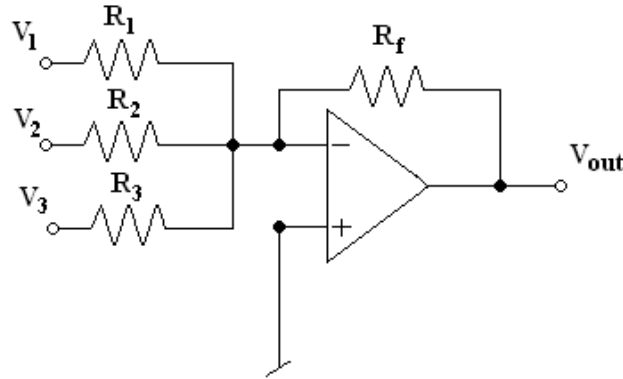
The relaxation oscillator consists of UJT and a capacitor C which is charged through resistor R_E when interbase voltage V_{BB} is switched on. During the charging period, the voltage across the capacitor increases exponentially until it attains the peak-point voltage V_p . When the capacitor voltage attains voltage V_p , the UJT switches on and the capacitor C rapidly discharges via B_1 and capacitor voltage drops to the value V_v . The device then cuts off and capacitor commences charging again. The cycle is repeated continually generating a saw-tooth wave-form across capacitor C.

Q.60 Write short notes on any **TWO** of the following:

- (i) An Operational Amplifier as an adder and as a voltage follower.

- (ii) Differential Amplifier, explain CMRR and the uses of a differential amplifier.
 (iii) IC Fabrication techniques – for monolithic IC's.
 (iv) Realization of an Integrator and a Differentiator using OPamps. (2 x 7)

Ans:



(i) An Operational Amplifier as an adder and as a voltage follower.

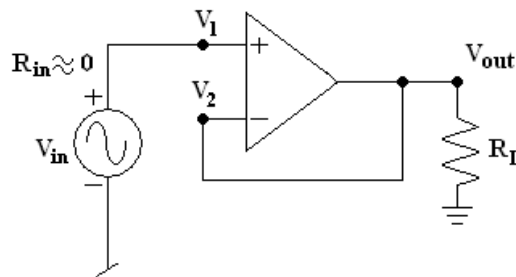
This circuit can add ac or dc-signals. Thus provides an output-voltage proportional to or equal to the algebraic sum of two or more input voltages multiplied by a constant gain-factor.

$$V_{out} = -R_f \left[\frac{V_1}{R_1} + \frac{V_2}{R_2} + \frac{V_3}{R_3} \right]$$

If $R_1 = R_2 = R_3 = R_f$, Then $V_{out} = -(V_1 + V_2 + V_3)$.

Voltage follower:

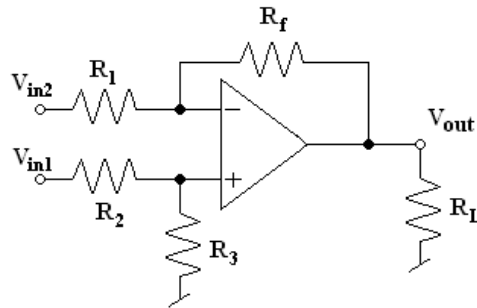
The output-voltage of the op-amp exactly track the input voltage both in sign and magnitude. This is the reason that this current is called voltage-follower.



(ii) Differential Amplifier:

Sometimes it necessary to amplify the voltage difference between two input-lines neither of which is grounded. In this case, the amplifier is called a differential-amplifier.

This reduces the amount of noise injected into the amplifier, because any noise appears simultaneously on both input-terminals and the amplifying circuitry rejects it being a common mode signal.



CMRR: It is defined as the ratio of differential voltage-gain to common mode voltage gain and it is given as

$$CMRR = \frac{A_d}{A_{C_M}}$$

If a differential amplifier is perfect, CMRR would be infinite because in that case common mode voltage gain A_{C_M} would be zero.

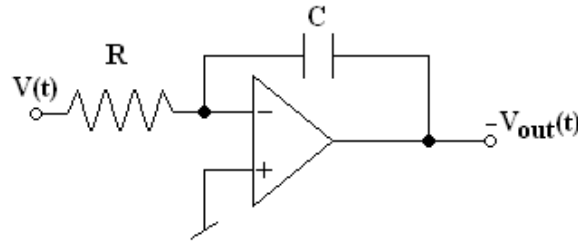
(iii) IC-Fabrication Techniques for-monolithic IC's:

A monolithic IC is one in which all circuit components and their interconnections are formed on a single thin wafer, called the substrate. The basic production process for monolithic IC's are given below:

1. A typical P-type or N-type is grown in dimensions of 250mm length and 25mm diameter. The crystal is then cut by a diamond saw into thin slices called wafers. These wafers after being lapped and polished to mirror finish serve as the base or substrate on which hundreds of IC's are produced.
2. Epitaxial Growth: On high resistivity P-type substrate a low resistivity 25 μ m thick layer of N-type is epitaxially grown. On this epitaxial-layer all active and passive components of an IC are formed.
3. Insulation layer: In order to prevent the contamination of the epitaxial layer, a thin layer of SiO_2 is formed over the entire surface.
4. Photolithographic Process: The monolithic technique requires the selective removal of the SiO_2 to form openings through which impurities may be diffused, if required.
5. Isolation Diffusion: SiO_2 layer is removed from the desired areas using photolithographic etching process. The remaining SiO_2 layer serves as mask for the diffusion of acceptor impurities. This process results in formation of N-type regions called the isolation islands.
6. Base Diffusion: During this process new layer of SiO_2 is formed over the wafer. The new pattern of openings is created depending upon the circuit needs.
7. Emitter Diffusion: A layer of SiO_2 again formed over the entire surface and openings in the P-type regions are formed again by employing masking and etching process.
8. Aluminium Metallization: For making electrical connections between various components of the IC, several windows are opened on a newly created SiO_2 layer.

(iv) Realization of an Integrator and a Differentiator using OPAMps.

An integrator is a circuit that performs a mathematical operation called integration.



$$i(t) = \frac{v(t)}{R} \quad \text{and} \quad V_{out}(t) = \frac{-1}{C} \int \frac{v(t)}{R} dt$$

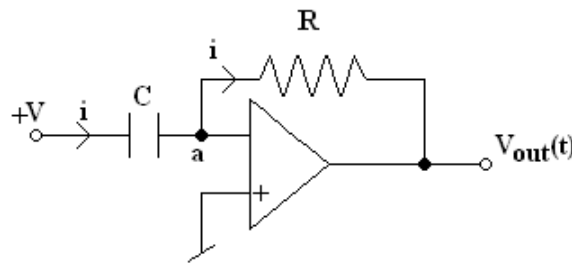
Differentiator: It's function is to provide an output voltage proportional to the rate of change of the input voltage.

$$q = C.V_c$$

$$i = \frac{dq}{dt} = \frac{d}{dt} C.V_c = C. \frac{dV_c}{dt}$$

$$\therefore V_{out} = -iR = -\left[C. \frac{dV_c}{dt} \right] R$$

$$V_{out} = -RC. \frac{dV_c}{dt}.$$



- Q.61** What is a passive circuit element? Name the most commonly used passive circuit elements. Briefly explain the following:
- (i) Thin film resistors.
 - (ii) Wire-wound resistors.
- (8)**

Ans:

Passive components by themselves are not capable of amplifying or processing an electrical signal. Passive components include resistors, inductors and capacitors.

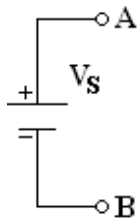
(i) Thin film resistors- It is constructed by using film deposition techniques of depositing a thin film of resistive material on to an insulating substrate. Desired values are obtained by either trimming the layer thickness or by cutting helical grooves of suitable pitch along its length. During this process the value of the resistance is monitored closely and cutting of grooves is stopped as soon as the desired value of resistance is obtained.

(ii) Wire wound resistors – These resistors are a length of wire wound around an insulating cylindrical core. Usually wires made of materials such as Constantan and Manganin which have high resistivity and low temperature coefficients are employed. The complete wire wound resistor is coated with an insulating material such as baked enamel.

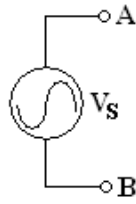
- Q.62** Describe the V-I characteristic of a practical voltage source. Find the largest practical value of load resistance to provide constant current from a current source with $I_s = 30\text{mA}$ and $R_s = 1\text{K}\Omega$. Comment on the variation of current from the short-circuited value.

(8)

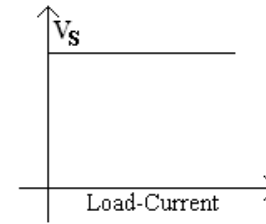
Ans:



(a) DC-voltage source

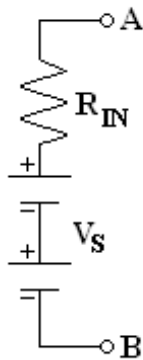


(b) AC-voltage source

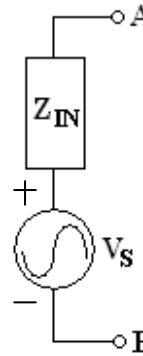


V-I characteristics

An ideal voltage source is not practically possible. There is no voltage source which can maintain its terminal voltage constant even when its terminals are short circuited. An ideal voltage source does not exist in practice. A practical voltage source can be considered to consist of an ideal voltage source in series with an impedance. The impedance is called internal impedance of the source.



Practical DC-voltage Source



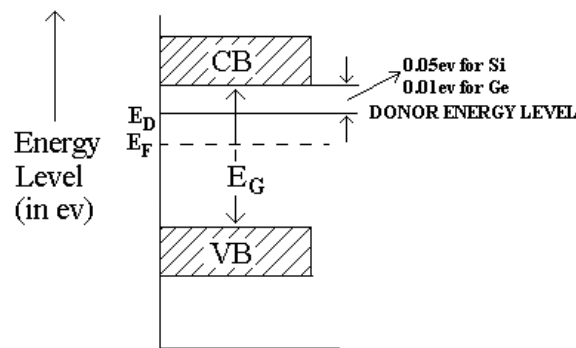
Practical AC-voltage Source

$$I_S = \frac{V_S}{R_{IN}} \Rightarrow R_{IN} \cdot I_S = V_S$$

$$\therefore V_S = 30V \text{ and } V = I \cdot R_L$$

Q.63 What is an N-type semiconductor? Write its energy band diagram. (5)

Ans:



Energy band diagram for N-Type semiconductor

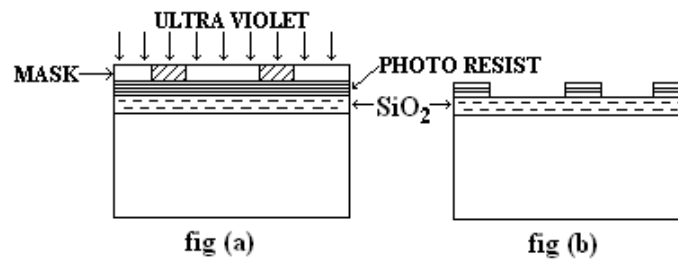
When a small amount of pentavalent impurity such as Arsenic, Antimony, Bismuth or Phosphorous is added to pure semi-conductor crystals during the crystal growth, the resulting crystal is called N-type extrinsic semi conductor.

Q.64 What is monolithic IC? Explain photolithographic Process in monolithic IC Production. (8)

Ans :

The word monolithic is derived from Greek mono meaning 'single' and lithus meaning stone. Thus monolithic circuit is built into a single stone or single crystal i.e., in monolithic IC's all circuit components and their interconnections are formed into or on the top of a single chip of silicon.

Photolithographic Process :



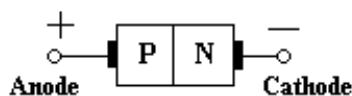
The monolithic technique requires the selective removal of the SiO_2 to form openings through which impurities may be diffused. The Photolithographic process shown in the figures (a&b) is used for this purpose.

During the process wafer is coated with a thin layer of photosensitive material (Kodak photo resist). The negative or stencil of the required dimensions is placed as a mask over the photo-resist as shown in fig(a). This wafer surface with mask is exposed to the ultra violet light. Due to UV light the photo-resist below the transparent portions of the mask becomes polymerised. The mask is now removed and the wafer is developed by using a chemical like trichloroethylene. The chemical dissolves the unpolymerised portions of the photo-resist film and leaves the surface as shown in fig (b). The oxide not covered by polymerised photo-resist is then removed by immersing the chip in an etching solution HCL. After etching and diffusion of impurities the resist mask is stripped off with a chemical solvent like hot sulphuric acid (H_2SO_4) and by means of mechanical abrasion process.

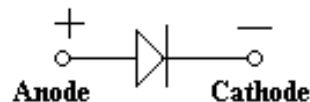
Q.65 What is a PN junction? Draw its circuit symbol. What is the convention followed in writing its symbol? Illustrate its characteristic and make it self explanatory. (6)

Ans:

The PN junction is produced by placing a layer of P type semiconductor next to the layer of N type semiconductor. The contact surface is called PN junction.



(a) Circuit Symbol



(b) Graphical Symbol

The graph plotted between potential difference across the PN junction and the circuit current is known as volt-ampere characteristics.

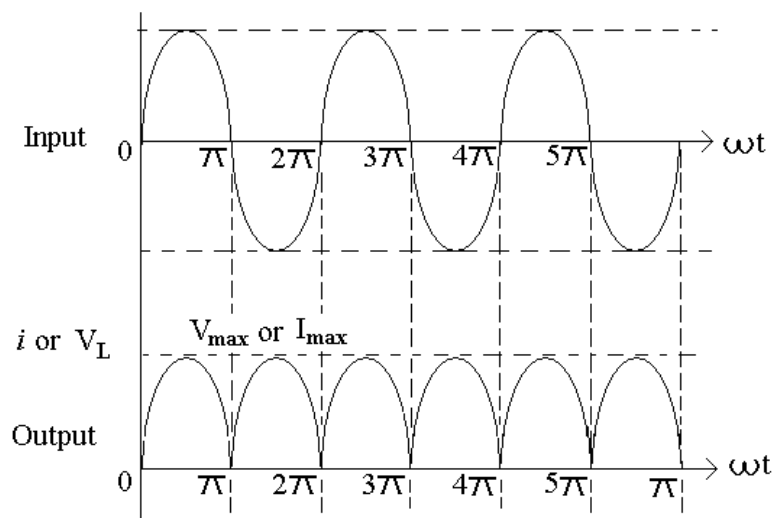
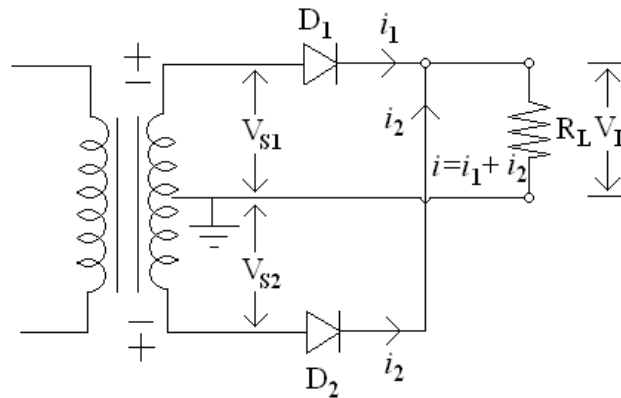
Forward Characteristics: When the external voltage is zero, i.e., when the circuit is open, the potential barrier at the junction does not allow the flow of current and, therefore, the circuit current is zero.

With forward bias to PN junction, very little current, called the forward current flows until the forward voltage exceeds the junction barrier potential. As the forward voltage increased to the knee of characteristics, the potential barrier is completely eliminated, forward current increases linearly with the increase in forward voltage.

Reverse characteristics: When the reverse bias is applied, the potential barriers at junction is increased. Therefore, the junction resistance becomes very high and there is no possibility of a majority carriers flowing across a reverse-biased junction. But still minority carriers generated on each side can cross the junction. This results in a very small current which is known as reverse current.

Q.66 Explain the operation of a two-diode full wave rectifier circuit. (7)

Ans:



When the top of the transformer secondary winding is positive, the anode of diode D_1 is positive with respect to cathode and anode of diode D_2 is negative with respect to cathode. Thus only diode D_1 conducts, being forward biased and current flows from cathode to anode of diode D_1 , through load resistance R_L .

During the second half-cycle of the input voltage polarity is reversed, making the bottom of the secondary winding positive with respect to centre-tap and thus diode D_2 is forward biased and the diode conducts and current flows the load resistance R_L .

Q.67 How are Zener diodes specified? Define the important specification factors for the device. (5)

Ans:

Specification of typical Zener diode at 25°C ambient are given below.

$V_{ZT} : 20 \text{ V} \pm 10\%$; $I_{ZT} : 12.5 \text{ mA}$ for $V_{ZT} = 20 \text{ V}$;

$I_{ZK} = 0.25 \text{ mA}$ for $V_{ZK} = 12 \text{ V}$; $I_{ZM} : 32 \text{ mA}$; $r_{ZK} = 22 \Omega \text{ max}$;

$P_{Z\text{max}} : 1 \text{ W}$; $I_R = 1 \mu\text{A}$ for $V_R : 6 \text{ V}$

A Zener diode is specified by its breakdown voltage V_Z , breakdown current I_{ZK} , the maximum power dissipation $P_{Z(\text{max})}$ and Zener-impedance measured at test point, Z_{ZT} .

Zener Impedance: Zener impedance Z_Z is essentially the dynamic resistance of a Zener diode. It is defined as the reciprocal of the slope of the Zener curve

$$\text{i.e. } r_Z = \frac{\Delta V_Z}{\Delta I_Z}$$

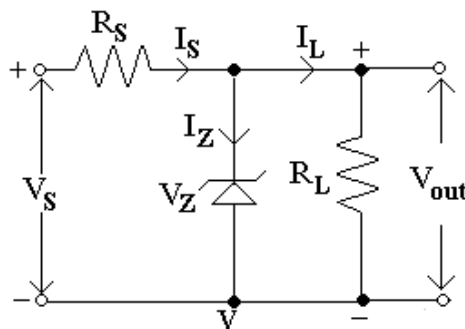
Where ΔV_Z and ΔI_Z are the small variations in voltage and current respectively.

Zener Voltage (V_Z) and Zener Current (I_Z):

When the reverse bias on a crystal diode is gradually increased, a point is reached when the junction breakdown and a reverse current increases abruptly. The breakdown voltage is called Zener Voltage (V_Z) and the sharply increased current is called the Zener Current (I_Z).

Q.68 Establish the theory of a Zener diode shunt regulator. (7)

Ans:



Above circuit diagram shows Zener diode can be used as a voltage regulator to provide a constant voltage from a source whose voltage may vary appreciably. A resistor R_S is necessary to limit the reverse current through the diode to safer value.

As long as voltage across the load resistor R_L is less than the break-down voltage V_Z , the Zener diode does not conduct, the resistors R_S and R_L constitute a potential divider across

V_S . At an increased supply voltage V_S , the voltage drop across load resistor becomes greater than the Zener breakdown voltage. It then operates in its break down region. The series resistor R_S limits the Zener current I_Z from exceeding its rated I_{Zmax} because Zener

current is given as
$$I_Z = \frac{V_S - V_Z}{R_S}$$

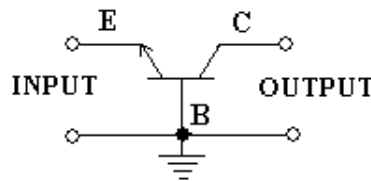
So, $I_S = I_Z + I_L$

Q.69 What are the three modes in which a transistor can operate? Explain the meaning of each mode of operation. (9)

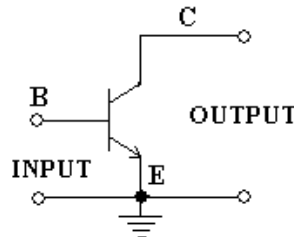
Ans:

The three modes of operations of a transistor are

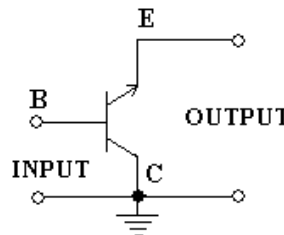
(1) **Common – Base configuration** – In common base configuration, input is connected between emitter base and output is taken across collector and base.



(2) **Common – Emitter configuration** – In common emitter configuration, input is connected between emitter base and output is taken across collector and emitter. This emitter is common to both input and output circuits.



(3) **Common – Collector configuration** – In common collector configuration, input is applied between base and collector while the output is taken across collector and emitter. Thus the collector forms the terminal is common to both input and output circuits.

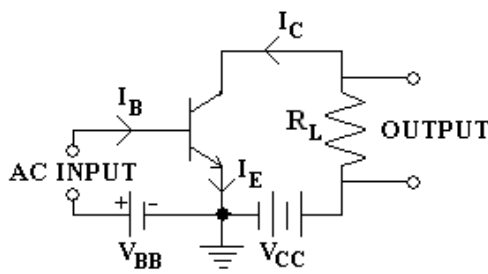


Q.70 Draw the circuits of an NPN and a PNP transistor in CE configuration. Define the following:

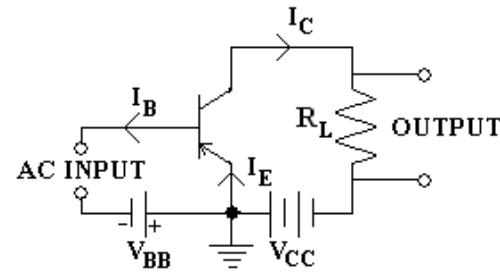
- (v) CE dc current gain.
- (vi) CE ac current gain.

(4)

Ans:



CE-N-P-N-Transistor



CE-P-N-P-Transistor

The output characteristics used to determine the dc- current gain β and ac current gain β_o is as follows.

DC current gain $\beta = I_C / I_B$

and AC current gain, $\beta_o = \Delta I_C / \Delta I_B$

$V_{CE} = \text{constant.}$

Q.71 What is a field effect transistor (FET)? Which are the different types of FET's available? Draw the circuit arrangement for obtaining the drain characteristics of a JFET and explain the procedure for obtaining the above characteristic curves. Illustrate the typical drain characteristic curves for the device. **(13)**

Ans:

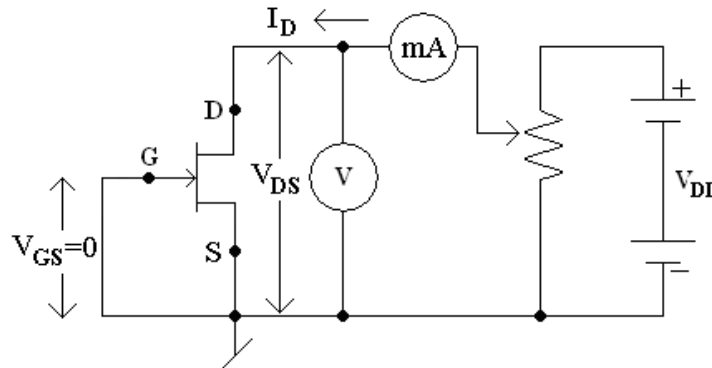
The device is called the FET because the drain current is controlled by the effect of the extension of the field associated with the depletion region developed by the reverse –bias at the gate.

Types – There are two major categories of FET namely

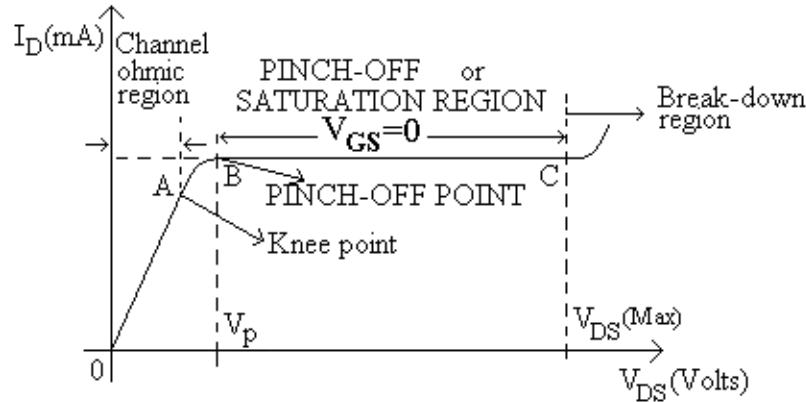
(1) Junction field effect transistor

(2) The Insulated –gate field effect transistor (MOSFET or MOST's)

Output or Drain characteristics- The curve drawn between drain current I_D and drain source voltage V_{DS} with gate- to- source voltage V_{GS} as the parameters is called the drain or output characteristic.



Circuit Diagram



Initially when V_{DS} is zero, there is no attracting potential at the drain, so no current flows in spite of the fact that the channel is fully open. Thus given drain-current $I_D = 0$. For small applied voltage V_{DS} , the N-type bar acts as a simple semiconductor resistor, and the drain current I_D increases linearly with the increase in V_{DS} , upto the knee point. This region of the curve is called the **Channel ohmic –region**.

With the increase in drain current I_D the ohmic voltage drop between the source and channel region reverse-biases the gate junction. The reverse biasing of the gate junction is not uniform throughout. The reverse-bias is more at the drain end than that at the source-end of the channel, so with the increase in V_{DS} , the conducting portion of the channel begins to constrict more at the drain-end. Eventually a voltage V_{DS} is reached at which the channel is pinched off.

The drain current I_D no longer increases with the increase in V_{DS} . It approaches a constant saturation value. The value of voltage V_{DS} at which the channel is pinched off is called the pinch-off voltage V_P . The pinch off voltage V_P , is not too sharply defined on the curve, where the drain current I_D begins to level off and attains a constant value. From point A to the point B, the drain current I_D increases with the increase in voltage V_{DS} following a reverse square law. The region of the characteristic in which drain current I_D remains fairly a constant is called the pinch off region. It is also called the saturation region of the amplifier-region. In this region the JFET operates as a constant current device, since the drain current remains almost constant. The drain current in the pinch off region with $V_{GS} = 0$ is referred to the drain source saturation current I_{DSS} .

Drain current in the pinch off region is given by Shockley's equation

$$I_D = I_{DSS} \left[1 - \frac{V_{GS}}{V_P} \right]^2 = I_{DSS} \left(1 - \frac{V_{GS}}{V_{GS(OFF)}} \right)^2$$

Where I_D is the drain current at a given gate source voltage V_{GS} , I_{DSS} is the drain current with gate shorted to source and $V_{GS(off)}$ is gate source cut-off voltage.

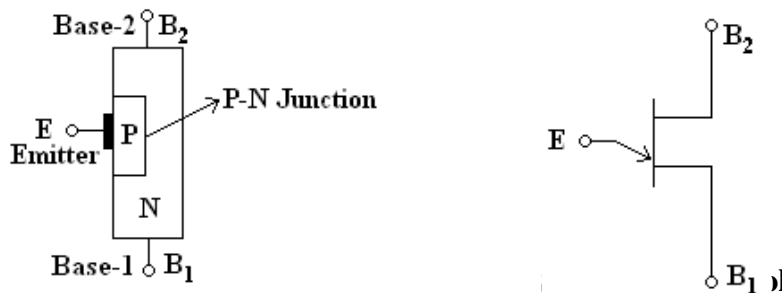
If the drain source voltage V_{DS} is continuously increased, a stage will come when the gate channel junction breakdown. At this point the drain current increases very rapidly, and the JFET may be destroyed. This happens because the charge carriers making up the saturation current at the gate channel junction accelerate to a high velocity and produces an avalanche effect.

DE05
DE06ELECTRICAL ENGINEERING
BASIC ELECTRONICS

Q.72 What is a unijunction transistor? Compare it with an ordinary diode & briefly describe its construction. Draw its circuit symbol and equivalent circuit. (9)

Ans:

Unijunction transistor is also called the double base diode is a two layer, three terminal solid state switching device. The device has unique characteristic that when it is triggered, its emitter current increases regeneratively until it is restricted by emitter power supply. The device, because of one PN junction, is quite similar to a diode but it differs from an ordinary diode that it has three terminals.



Construction- The basic structure of a unijunction transistor is shown in the above fig. It essentially consists of a lightly doped N-type silicon bar with a small piece of heavily doped P-type material alloyed to its one side to produce single P-N junction. The single P-N junction accounts for the terminology unijunction.

Q.73 What is an integrated circuit? What are its limitations? (5)

Ans:

An integrated circuit consists of several interconnected transistors, resistors, capacitors etc., all contained in one small package with external connecting terminals.

Limitations-

1. In an IC, the various components are part of a small semiconductor chip and the individual component or components cannot be removed or replaced, therefore, if any component in an IC fails, the whole IC has to be replaced by a new one.
2. Limited power rating as it is not possible to manufacture high power.
3. Need of connecting inductors and transformers exterior to the semiconductor chip as it is not possible to fabricate inductors and transformers on the semiconductor chip surface.
4. Operation at low voltage, as IC's function at fairly low voltage.
5. High grade P-N-P assembly is not possible.
6. Low temperature co-efficient is difficult to be achieved.
7. Difficult to fabricate an IC with low noise.

Q.74 Define the term 'work-function' of a metal. What is thermionic emission? (2)

Ans:

The work function of a metal may be defined as the difference between the energy required to move an electron of a metal to infinitely large distance and maximum energy an electron can have at absolute zero of temperature.

A very common method used for electron emission is by heating the metal piece to a high temperature.

The process of electron emission from the surface of a metal into the surrounding space by heating the material to a very high temperature is known as **thermionic emission**.

$E_w = E_B - E_F$ where E_w work function of a metal,

E_B is the total barrier an electron has to overcome for coming out of the metal surface,

E_F is Fermi level of energy.

Q.75 List the characteristics of an ideal and a practical OPAMP. (6)

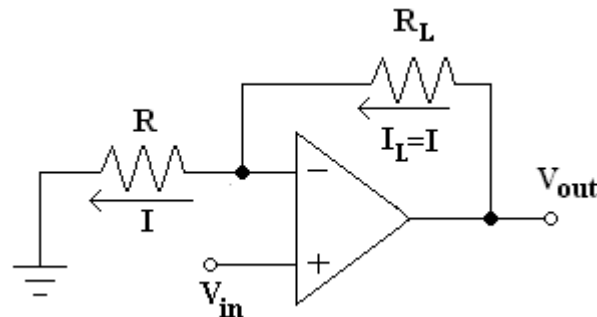
Ans:

Characteristics of an ideal and a practical OPAMP

1. It's open loop gain A is infinite.
2. It's input resistance R_{in} is infinite. It means that the input current is zero and so it does not load the source.
3. It's output impedance R_{out} is zero. Output voltage V_{out} is independent of the current drawn by the load.
4. Perfect balance i.e. Differential input voltage $V_d = V_2 - V_1$ is essentially zero.
5. Infinite frequency bandwidth.
6. Drift of characteristics with temperature is not.
7. CMRR is infinite so that amplifier is free from undesired common mode signals such as pick-ups thermal noise etc.
8. Slew rate is infinite.
9. Output voltage is zero when input voltage is zero i.e. Offset voltage is zero.

Q.76 Draw the circuit of an OPAMP V-to-I converter with grounded load and derive the equation for the current through the load. (6)

Ans:



V to I-Converter

In industrial electronics, it is necessary to provide a current proportional to certain voltage, even though the load resistance may vary. A circuit which can perform this job is called a voltage to current converter.

$$I_L = I = \frac{V_{in}}{R}$$

DE05
DE06

ELECTRICAL ENGINEERING
BASIC ELECTRONICS

Q.77 What are active and passive components? Categorise the following components into these categories. Metallized polyester capacitor, Preset Filter circuits, Audio-frequency chokes, FET, Vacuum tubes. **(4+4)**

Ans:

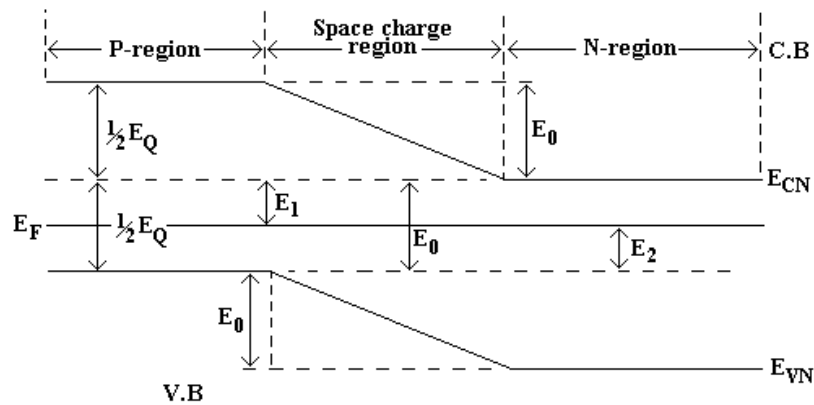
All electronic circuits, however complicated contain a few basic components – two active and three passive. Though passive components by themselves are not capable of amplifying or processing an electrical signal but these components are as important as active ones.

Active components – FET, Vacuum tubes

Passive components – Metallized polyester capacitors, preset filter circuits, audio frequency chokes.

Q.78 Draw the energy band diagram of a P-N junction under open-circuited condition. Clearly indicate energy levels in P-region, space region and N-region. How will it be modified if P-N junction is forward biased? **(8)**

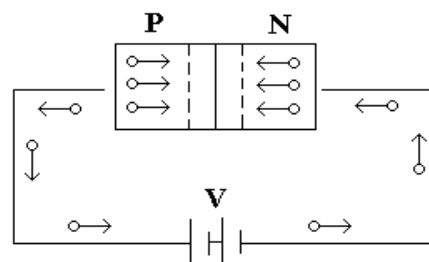
Ans:



If the external bias voltage were set equal to zero, the P-N junction would be short-circuited. Under these conditions no current can flow i.e. $I = 0$ and electrostatic potential V_0 remains unchanged and equal to the value under open circuit conditions.

Suppose forward bias voltage V is increased until V approaches junction potential V_0 . If V were equal to V_0 , the barrier would disappear and the current could be arbitrarily large, exceeding diode rating. In practice, barrier cannot be reduced to zero because, as the current increases without limit, the bulk resistance of the crystal and the resistance of the ohmic contacts will limit the current.

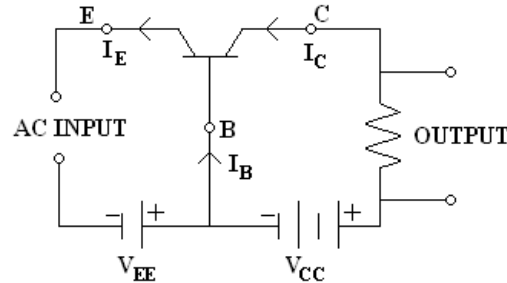
Thus it is no longer possible to assume that all the voltage V appears as change across the P-N junction.



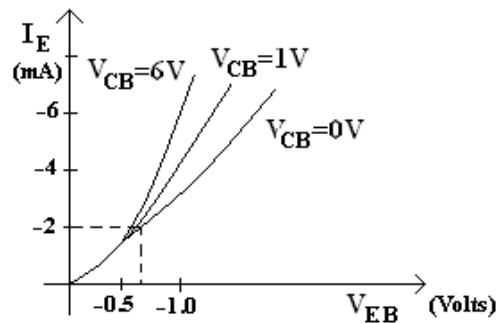
Forward Biasing

Q.79 Draw input and output characteristics of common base transistor configuration. (8)

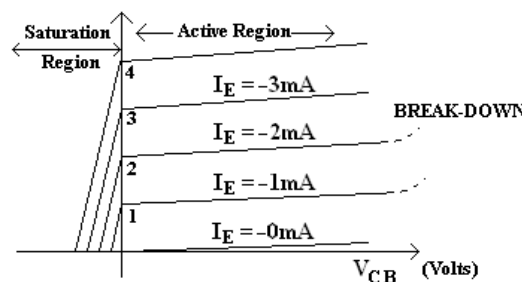
Ans:



Common-Base NPN transistor



Input characteristics for common-base NPN transistor



Output characteristics for common-base NPN transistor

$$\beta = \frac{\Delta I_C}{\Delta I_B} \text{ and } \alpha = \frac{\Delta I_C}{\Delta I_E} = \frac{\Delta I_C}{\Delta I_C + \Delta I_B}$$

$$\text{or } \frac{1}{\alpha} = \frac{\Delta I_C + \Delta I_B}{\Delta I_C} = 1 + \frac{1}{\beta} = \frac{1 + \beta}{\beta}$$

$$\text{hence } \alpha = \frac{\beta}{1 + \beta}$$

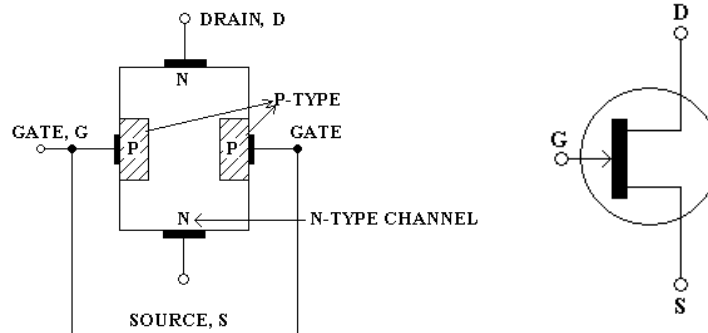
$$\text{and } \beta = \frac{\alpha}{1 - \alpha}$$

DE05
DE06

ELECTRICAL ENGINEERING
BASIC ELECTRONICS

Q.80 Sketch and explain the basic structure of an N-channel junction field effect transistor. (8)

Ans:



(a) N-channel JFET

N-Channel JFET

In an N-channel JFET a N-type silicon bar referred to as the channel, has two smaller pieces of P-type silicon material diffused on the opposite sides of its middle part, forming P-N junctions. The two P-N junctions forming diodes or gates are connected internally and common terminal, called the gate terminal is brought out. Ohmic contacts are made at the two ends of channel one lead is called the source terminal and the other drain terminal D. The silicon bar behaves like a resistor between two terminals D and S. The gate terminal is used to control the flow of current from source to drain.

Q.81 Why is a FET known as a unipolar device? How do you compare this device with BJT? (8)

Ans:

In field effect transistors current conduction is only by one type of majority carriers (either by electrons or holes) and therefore, these are called unipolar transistor.

- 1) It's operation depends upon the flow of majority carriers only. It is, therefore, a unipolar device. In BJT both majority and minority carriers take part in conduction and therefore BJT is sometimes called the bipolar transistor.
- 2) It has high input impedance ($\cong 100\text{M}\Omega$) because its input circuit is reverse biased, and so permits high degree of isolation between the input and output circuits. However, the input circuit of an ordinary BJT transistor is forward biased and, therefore, ordinary transistor has low input impedance.
- 3) JFET carries very small current because of reverse biased gate and, therefore, it operates just like a vacuum tube where control grid carries extremely small current and input voltage controls the output current. This is the reason that JFET is essentially a voltage driven device. BJT is a current operated device since input current controls the output current.

Q.82 Explain the terms “work function” and “threshold frequency” in connection with electron emission. Name one material suitable for thermionic emission and one material for photo-emission. (8)

Ans:

The work function of a metal may be defined as the difference between the energy required to move an electron of a metal to an infinitely large distance and maximum energy an electron can have at absolute zero of temperature.

Threshold frequency – The minimum frequency which can cause photo emission is called the threshold frequency and is given by $f_0 = e\phi/h$ where e = electronic charge, h = Plank's constant ϕ = work function.

Photo emission materials- Alkaline material such as sodium, potassium, cesium or rubidium.

Thermionic emission materials- Carbon, cesium, molybdenum, nickel, platinum.

- Q.83** What is photoelectric emission? How is the electron emission affected if
- the frequency and
 - the intensity of the incident radiations are increased? **(8)**

Ans:

When the surface of certain alkaline material such as sodium, potassium, cesium is illuminated by a beam of light or ultraviolet radiations the electrons are emitted. This phenomenon is called photoelectric emission.

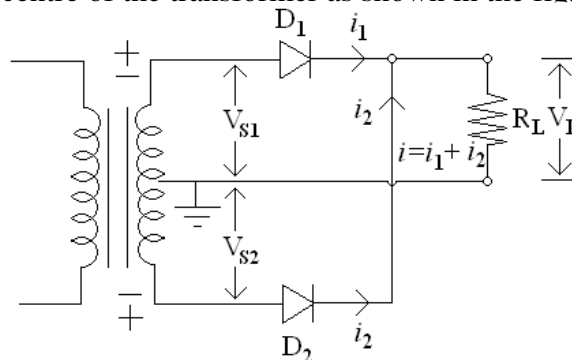
The work function of the alkaline materials is very low and therefore when energy of the light radiations (called photons) or the energy of the ultraviolet radiations (called quanta) fall on the alkaline material, it gives sufficient energy to the free electrons of the material to speed up sufficiently to overcome the surface restraining forces of the metal and hence emission takes place. The electrons emitted in this way are called photo electrons. The number of electrons emitted depends upon the intensity of light beam falling upon the emitter surface and the frequency of radiations. This property is very useful for the measurement of intensity of illumination.

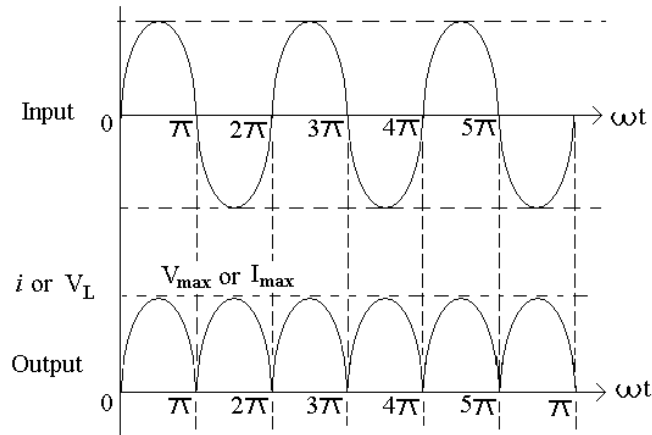
If the frequency of incident radiations is greater than f_0 then the incident radiations has more energy.

- Q.84** Explain the working of a full-wave rectifier using centre-tapped transformer. **(8)**

Ans.

In centre tap rectifier, the ac input is applied through a transformer, the anodes of the two diodes D_1 and D_2 are connected to the opposite ends of the centre tapped secondary winding and two cathodes are connected to each other and are connected through the load resistance R_L and back to the centre of the transformer as shown in the fig.





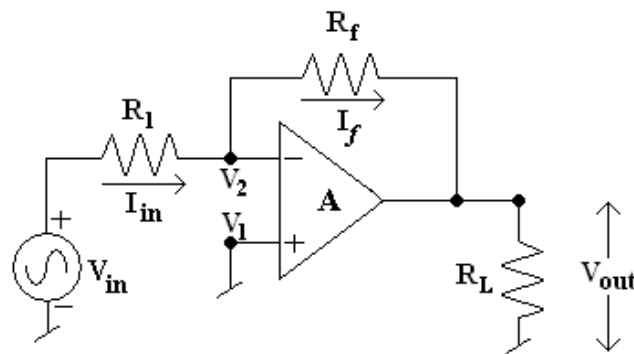
Input and Output waveform

When the top of the transformer secondary winding is positive, diode D_1 is positive with respect to cathode and anode of diode D_2 is negative with respect to cathode. Thus only diode D_1 conducts, being forward biased and current flows from cathode to anode of diode D_1 through load resistance R_L and top half of the transformer secondary, making cathode end of load resistance R_L positive.

During the second half cycle of the input voltage the polarity is reversed, making the bottom of the secondary winding positive with respect to centre tap and thus diode D_2 is forward biased and diode D_1 is reversed biased.

- Q.85** Draw the schematic diagram of an op-amp connected as
- (i) an inverter
 - (ii) a scale changer
 - (iii) a phase shifter and
 - (iv) an adder.
- (8)**

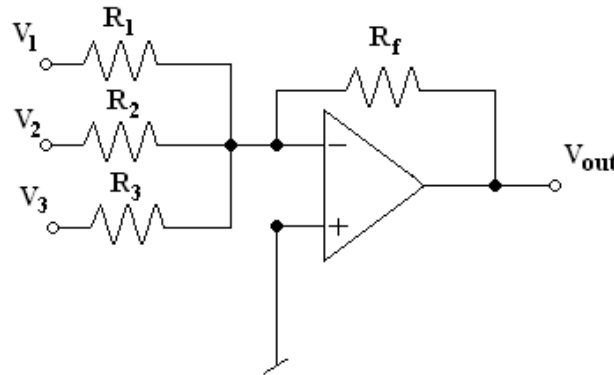
Ans:



Inverting Amplifier

Scale changer – If the ratio $\frac{R_f}{R_1} = K$, a real constant, then amplifier gain $A_f = -K$. Thus the input voltage scale has been multiplied by a factor $-K$ to give the output voltage scale. The circuit, can act as negative - scaler or scale changer.

Phase shifter- In the inverting amplifier, resistors R_f and R_1 in the circuit are replaced by Z_f and Z_1 respectively so that Z_f and Z_1 are equal in magnitude but differ in phase angle, the inverting OP- amp shifts the phase of the sinusoidal input voltage without making any change in it's amplitude. Thus any phase-shift from 0^0 to 360^0 can be obtained.



Summing Operational Amplifier

Q.86 Briefly explain the thin-film and thick –film methods of producing ICs. Discuss their advantages and limitations. (8)

Ans:

Thin and thick film IC's are larger than monolithic IC's but smaller than discrete circuits. These IC's can be used when power requirement is comparatively higher.

Thin film IC's are fabricated by depositing films of conducting material on the surface of a glass or ceramic base. By controlling the width and thickness of the films and by using different materials of selected resistivity resistors and conductors are fabricated.

Thick film IC's are sometimes referred to as printed thin film circuits. In their manufacturing process silk screen printing techniques are used to create the desired circuit pattern on a ceramic substrate.

IC's produced by thin or thick film techniques have the advantages of forming passive components with wider range and better tolerances, better isolation between their components, greater flexibility in circuit design and providing better high frequency performance than monolithic IC's.

However such IC's suffer from the drawbacks of larger physical size, comparatively higher cost and incapability of fabrication of active components.

Q.87 Differentiate between SSI, MSI, LSI and VLSI. (8)

Ans:

IC's can be classified on the basis of their chip size as given below:

- 1) Small Scale integration (SSI) – 3 to 30 gates/chip.
- 2) Medium Scale integration (MSI) – 30 to 300 gates/chip.
- 3) Large Scale integration (LSI) – 300 to 3000 gates/chip.
- 4) Very Large Scale integration (VLSI) – more than 3000 gates/chip.

DE05
DE06ELECTRICAL ENGINEERING
BASIC ELECTRONICS

- Q.88** Why colour coding system is used to indicate the value of a resistor? What is the role of a capacitor in an electronic circuit? Write a brief note on paper capacitors. (8)

Ans:

Some resistors are large enough in size to have their resistance values (in Ω) printed on the body. However there are some resistors, which are too small in size to have their resistance values printed on them. Hence, a system of colour coding is employed for indicating their values.

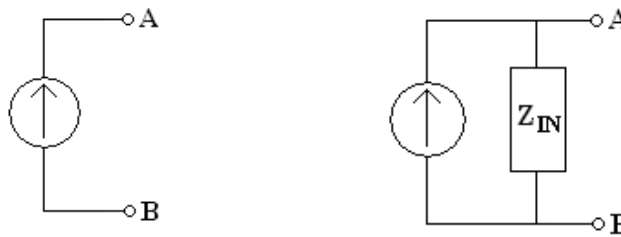
A capacitor is a physical device which is capable of storing energy by virtue of a voltage existing across it. The voltage applied across the capacitor sets up an electric field within it and the energy is stored in the electric field. A capacitor is basically meant to store electrons (or electrical energy), and release them when required.

Paper capacitor – Paper capacitors are the most widely used type of capacitors. Their popularity is due to their low cost and the fact that they can be built over a wide range of capacitance values. They are designed to withstand very high voltages. The leakage currents of paper capacitors are high and their tolerances are relatively poor.

- Q.89** Illustrate and explain the V-I characteristic of a practical current source. Comment on the equivalence between voltage source and current source. (6)

Ans:

An ideal current source is not practically possible. There is no current source which can maintain current supplied by it constant even when its terminals are open circuited.



A practical current source can be represented as shown in above fig. A practical current source can be considered to consist of an ideal current source in parallel with an impedance Z_{in} . The shunt impedance is called internal impedance of the source and accounts for the fall in output current with increase in load impedance.

A given voltage source with a series resistance can be converted into an equivalent current source with a parallel resistance. Conversely a current source with a parallel resistance can be replaced by an equivalent voltage source with a series resistance.

- Q.90** What is a semiconductor? Give its important properties. Briefly explain the energy band diagram for a semiconductor. (10)

Ans:

The group of materials which are neither good conductors nor good insulators are called semiconductors. At room temperature such materials have conductivities considerably lower than those of conductors and much higher than those of insulators such materials are

called semiconductors. The resistivity of various semiconductor materials lies in a very wide range from 10^{-4} to about $0.5 \Omega \cdot \text{m}$.

Properties-

- 1) Their resistance depends largely on various factors and therefore, it can be controlled.
- 2) The resistance of semiconductors decreases with the increase in temperature i.e. temperature coefficient of semiconductors is negative.
- 3) Semiconductors are non-linear resistor.
- 4) The resistivity of semiconductors changes considerably when even minute amounts of certain other substances called the impurities are added to them.

Energy Bands-

Within any given material there are two distinct energy bands in which electrons may exist. These two energy bands are valence band and conduction band and are separated by an energy gap in which no electron can normally exist.

The energy band of interest is the highest band or valence band. If a sufficient amount of energy is given to an electron in the valence band, the electron is free of the atomic structure. Such an electron is said to possess enough energy to be in the conduction band where it can take part in electric current flow. Free electrons (electrons in conduction band) can move readily under the influence of an external field.

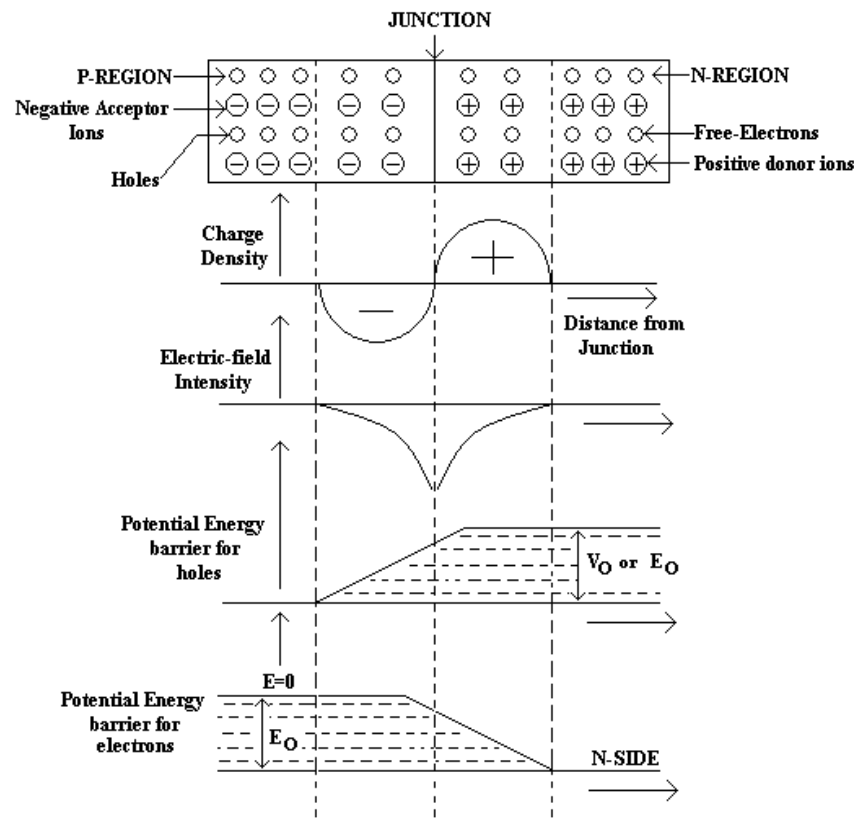
Q.91 Define the following as applied to a PN-junction:

- (i) Depletion region
- (ii) Width of the barrier
- (iii) Barrier voltage

Support your answer with neat illustrations.

(6)

Ans:



The negative potential on the P-side prevents the migration of any more electrons from the N-type material to the P-type material. Similarly the positive potential on the N-side prevents any further migration of holes across the boundary. Thus the initial diffusion of charge carriers creates a Barrier Potential at the junction.

The region around the junction is completely ionised. As a result, there are no free electrons on the N-side nor there are holes on the P-side. Since the region around the junction is depleted of mobile charges it is called the **Depletion Region**. The thickness of the depletion region (or layer) is of the order of 1 micron.

Barrier voltage depends on doping density, electronic charge and temperature, the first two factors are fixed thus making barrier potential dependent on temperature.

- Q.92** What do you mean by a voltage regulator? Distinguish between a linear regulator and a switching regulator. Draw the circuit of a simple emitter-follower regulator and briefly explain. (12)

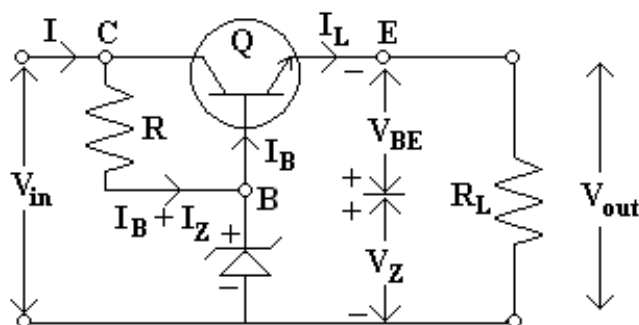
Ans:

The primary function of a voltage regulator is to maintain a constant dc output voltage. However, it also rejects ac ripple voltage that is not removed by the filters. The regulator may also include protective functions such as short-circuit protection, current-limiting, thermal-shut down or over-voltage protection.

Linear voltage regulator- The main drawback of linear voltage regulator is the power dissipation in the pass-transistor which is operated in its linear mode. Other drawbacks are regulated power supplies using these regulators require a step-down transformer and large sized filter capacitors to reduce the ripple.

Switching Regulators- In this the transistor is operated either in cut-off region or in the saturation region. This results in much less power dissipation in the pass-transistor. Switching regulators can provide large load currents at low voltages.

Emitter-follower regulator-



This circuit is called a series regulator because collector and emitter terminals of the transistor are in series with the load. The unregulated dc-supply is fed to the input-terminals and regulated output voltage V_{out} is obtained across the load resistor R_L . Zener diode provides the reference voltage and the transistor acts as a variable resistor, whose resistance varies with the operating conditions (Base current I_B)

$$V_{out} = V_Z - V_{BE}$$

DE05
DE06

ELECTRICAL ENGINEERING
BASIC ELECTRONICS

Q.93 What are the unique features of IC voltage regulators? (4)

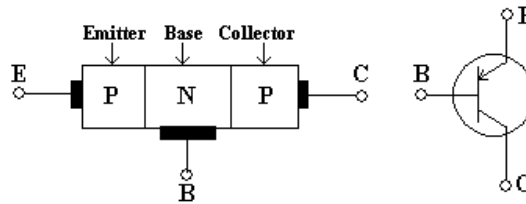
Ans :

IC voltage regulators are versatile and relatively inexpensive and are available with features such as programmable output, current-voltage boosting, terminal short circuit current limiting, thermal switching and floating operation for high voltage applications.

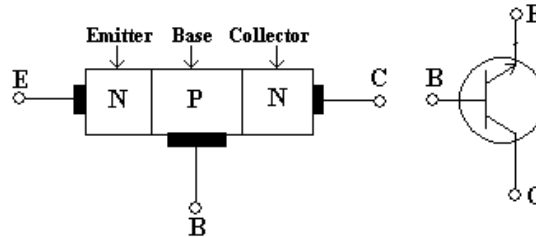
Q.94 How are BJTs classified? Draw the circuit symbol for each type. What are the advantages of transistors over electron tubes? (8)

Ans :

Transistors are of two types. P-N-P and N-P-N, behave exactly in the same way except change in biasing and majority carrier. In P-N-P transistors the conduction is by holes whereas in N-P-N transistors the conduction is by electrons.



P-N-P Transistor



N-P-N Transistor

Advantages over vacuum tubes-

Compact size, light weight, Rugged construction, more resistive to shocks and vibrations, instantaneous operation, low operating voltage, high operating efficiency and long life with essentially no ageing effect if operated with in permissible limits of temperature and frequency.

Q.95 Give a table of comparison between CE and CB configurations with regard to the important parameters. (4)

Ans :

COMMON BASE	COMMON EMITTER
Low input impedance($\cong 100\Omega$) Very high output impedance ($\cong 500K\Omega$)	Medium input impedance ($\cong 800\Omega$) Output impedance high ($\cong 50K\Omega$)

DE05
DE06

ELECTRICAL ENGINEERING
BASIC ELECTRONICS

Current gain less than unity. Voltage gain ≈ 150 Very small leakage current.	High current gain. Voltage gain ≈ 800 Very large leakage current.
--	---

Q.96 How does an FET differ from the conventional junction transistor? In the structure of an N-channel JFET, why the N-type bar is called a channel? Give the structure of a P-channel JFET. What is the difference between a JFET and a MOSFET? (9)

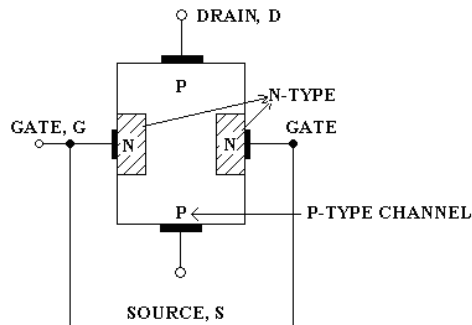
Ans :

JFET's operation depends upon the flow of majority carriers only. It is therefore a unipolar device. On the other hand BJT is sometimes called the bipolar transistor.

JFET has high input impedance, because its input current is reversed biased. However the input current of a BJT is forward biased and therefore ordinary transistor has low input impedance.

JFET is essentially a voltage driven device. BJT is a current operated device since input current controls the output current.

Channel – The region between the source and drain sandwiched between the two gates is called the channel and the majority carriers move from source to drain through this channel.



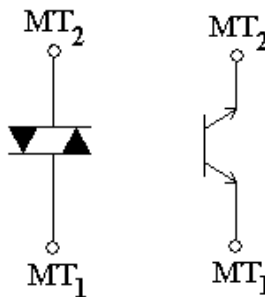
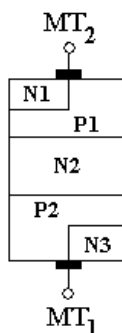
P-Channel JFET

Difference between a JFET and a MOSFET:-

1. JFET's can only be operated in the depletion mode whereas MOSFET's can be operated in either depletion or enhancement mode.
2. MOSFET's have input impedance much higher than that of JFET's. This is due to negligibly small leakage current.
3. JFET's have characteristic curves more flatter than those of MOSFET's indicating a higher drain resistance.
4. When JFET is operated with a reverse bias on the junction, the gate current I_G is larger than it would be in a comparable MOSFET.

Q.97 Write a brief note on DIAC. (7)

Ans :



Basic structure

Schematic Symbols

A DIAC is an important member of the thyristor and usually employed for triggering triacs. A DIAC is a two electrode bidirectional avalanche diode which can be switched from OFF state to the ON state for either polarity of the applied voltage.

A DIAC is a P-N-P-N structured four layer two terminal semiconductor device. MT₁ and MT₂ are the two main terminals of the device. There is no control terminal in this device.

Q.98 What is an OPAMP? Why is it called so? Briefly explain the following for an OPAMP

- (i) Input offset voltage
- (ii) Input bias current
- (iii) CMRR

(9)

Ans :

An operational amplifier is basically a multistage very high gain direct coupled negative feedback amplifier that uses voltage shunt feedback to provide a stabilized voltage gain.

An OPAMP is so called as it was originally designed to perform mathematical operations.

Input offset voltage – Input bias current $V_{in(offset)}$ defined as that voltage which is to be applied between the input terminals to balance the amplifier.

Input bias current –The OPAMP’s input is a differential amplifier. It may be made of BJT’s or FET’s. In either case these transistors are required to be biased and this takes current.

$$\text{i.e., } I_B = \frac{I_{B1} + I_{B2}}{2} \text{ for } V_{OUT} = 0$$

CMRR – It is defined as the ratio of differential voltage gain to common mode voltage gain and it is given as $CMRR = A_d/A_{CM}$.

Q.99 What do you mean by Passive components? Explain how the variable resistor can be used as a rheostat and Potentiometer with the help of symbols. Give their applications. (5)

Ans :

Passive components are those components which by themselves are not capable of amplifying or processing an electrical signal. Passive components include resistors, inductors and capacitors.



Symbols of Rheostats



Symbols of ‘POTS’

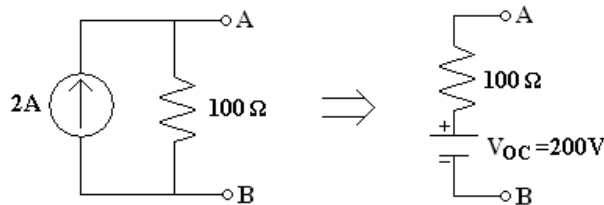
Variable resistors usually have three leads, two fixed and one movable. If contacts are made with only two leads of the resistor, the variable resistor is being used as a rheostat. Rheostats are usually employed to limit the current flowing in the circuit branches.

If all three contacts are employed in a circuit it is termed as a potentiometer or ‘POT’. POT’s are often used as voltage dividers to control or vary voltage across a circuit branch.

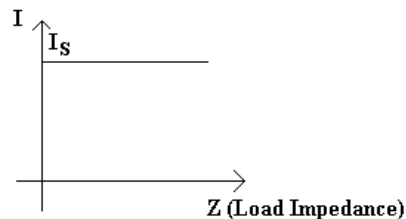
- Q.100** What is a Practical Current source; Explain its V-I characteristics. Convert an a.c. current source of 2A in parallel with an impedance of 100Ω into its equivalent voltage source. (6)

Ans :

Practical Current source is one in which if the load impedance is very small in comparison to the internal impedance of the source.



$$V_{oc} = I_s \cdot R_{IN} = 2 \times 100 = 200V$$



The current supplied by a source should remain constant irrespective of the load impedance.

- Q.101** Explain what do you understand by intrinsic, P-type and N-type semiconductors. Discuss the position of Fermi Level in each case with the help of Energy Band Diagram. (7)

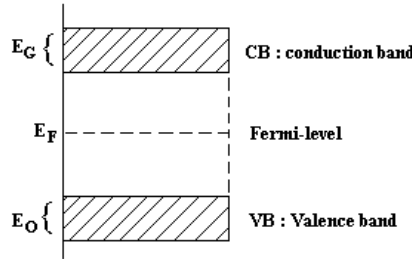
Ans :

An intrinsic semiconductor is one which is made of the semiconductor material in its extremely pure form.

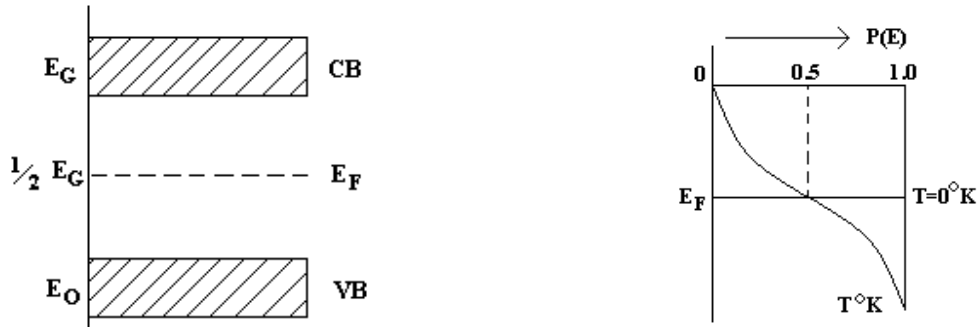
When a small amount of pentavalent impurity such as arsenic, antimony or phosphorous is added to a pure semiconductor crystal during the crystal growth, the resulting crystal is called the N-type extrinsic semiconductor.

When a small amount of trivalent impurity, such as boron, gallium, indium or aluminium is added to a pure semiconductor crystal during the growth the resulting crystal is called the P-type extrinsic semiconductor.

The Fermi level is simply a reference energy level. It is the energy level at which the probability of finding electron n energy units above it in the conduction band is equal to the probability of finding hole n energy units below it in the valence band.



Average energy level of Energy



Zero-energy reference level

In intrinsic semiconductor the Fermi level lies midway between the conduction and valence bands.

Q.102 Distinguish between Mobile Charge Carriers and Immobile Ions. (5)

Ans :

The mobility of electrons is more than that of holes because the probability of an electron having the energy required to move to an empty state in conduction is much greater than the probability of an electron having the energy required to move to the empty state in valence band. The mobility of an electron is double that of an hole.

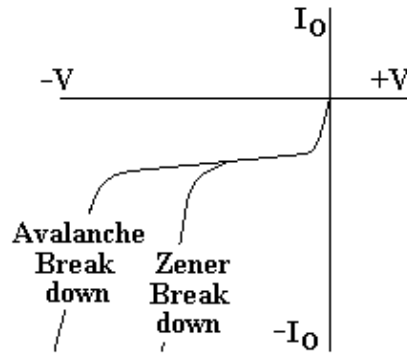
Q.103 What is breakdown diode? What is its use? Describe physically how two mechanisms of breakdown occur in a p-n junction diode. (7)

Ans :

Zener diode also sometimes called the breakdown diode is a PN junction diode specially designed for operation in the breakdown region in reverse bias condition.

The diode may use either Zener breakdown mechanism or avalanche breakdown mechanism.

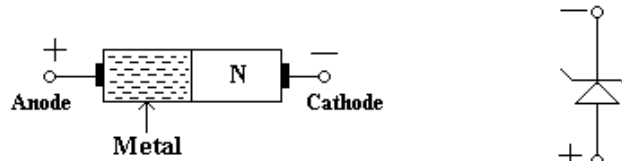
When the reverse bias on a crystal diode is gradually increased a point is reached when the junction breakdown and a reverse current increases abruptly, the breakdown region is the knee of the reverse characteristic.



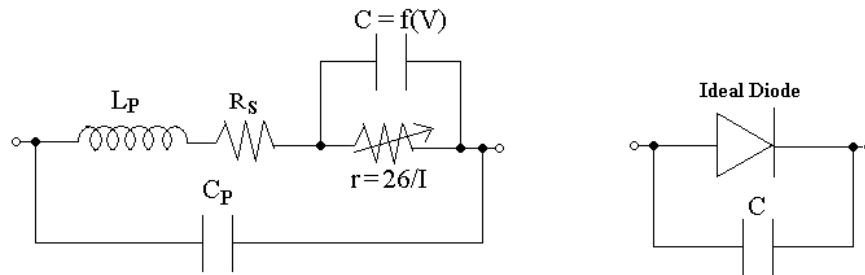
The minority carriers under reverse biased conditions flowing through the junction acquire a kinetic energy which increases in reverse voltage. At a sufficiently high reverse voltage the kinetic energy of minority carriers becomes so large that they knock out electrons from the covalent bonds of semiconductor material. As a result of collision, the liberated electrons in turn liberate more electrons and the current becomes very large leading to the breakdown of the crystal structure itself. This phenomenon is called the “Avalanche Breakdown”.

Q.104 What is Schottky diode? Why is it also called Hot-Carrier diode? How does it differ in construction from a normal P-N junction diode? **(5)**

Ans :



Schemaic Symbols of Schottky Diode



(a) Equivalent Circuit

(b) Approximate Equivalent Circuit

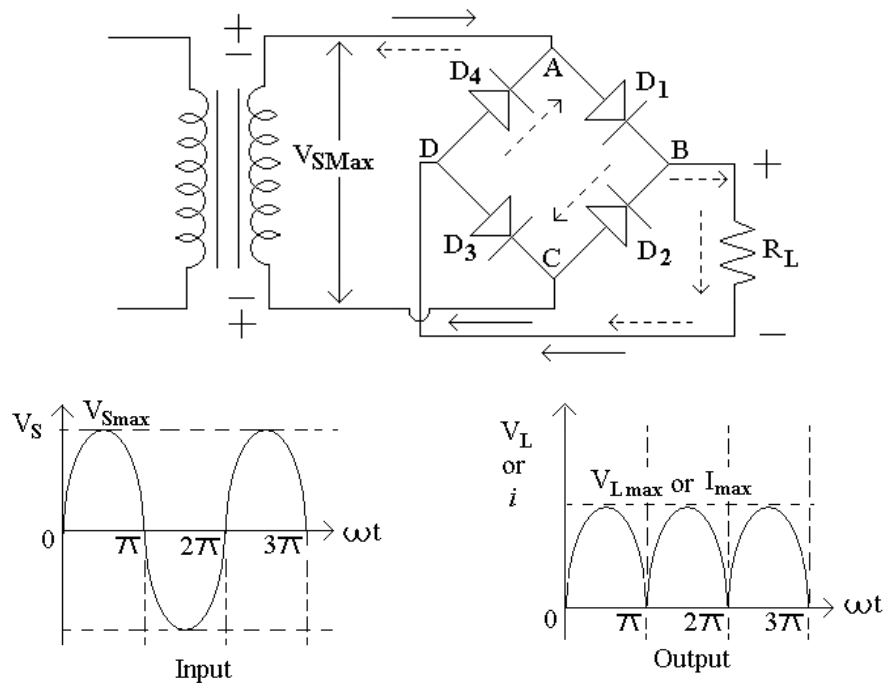
The reverse recovery time is so short in small signal diodes that its effect cannot be noticed at frequencies below 10MHZ or so. It becomes very important well above 10 MHz. The solution is a special purpose device called Schottky diode. Such a diode has no depletion layer eliminating the stored charges at the junction. Due to the lack of charge storage the Schottky diode can switch off faster than an ordinary diode.

Its construction is very different from the normal PN junction in which metal semiconductor junction is developed. On one side of the junction a metal is used and the other side of the junction N-type doped silicon is used.

In both materials, the electrons are the majority carriers. In the metal, the level of minority carriers is insignificant. When diode is unbiased, electrons on N-side have low energy levels than the electrons in the metal and so the electrons cannot cross the junction barrier called Schottky barrier. But when the diode is forward biased the electrons on the N-side gain enough energy to cross the junction and enter the metal. Since these electrons plunge into the metal with very large energy they are usually called the hot carriers and the diode is called the hot carrier diode.

Q.105 Draw the circuit diagram of Four-diode Full-wave Bridge Rectifier and explain its operation. What are its advantages and disadvantages? (6)

Ans :



When the upper end of the transformer secondary winding is positive, diodes D_1 and D_3 are forward biased and current flows through arm AB, enters the load at positive terminal, leaves the load at negative terminal and returns back flowing through arm DC. During this half of each input cycle, the diodes D_2 and D_4 are reverse biased, and so the current is not allowed to flow in arms AD and BC. The flow of current is indicated by solid arrows in the figure.

In the second half of the input cycle the lower end of ac supply becomes positive diodes D_2 and D_4 become forward biased and current flows through arm CB, enters the load at the positive terminal, leaves the load at the negative terminal and returns back flowing through arm DA. Flow of current has been shown by dotted arrows in the figure. Thus the direction of flow of current through the load resistance R_L remains the same during both half cycles of the input supply voltage.

Advantages-

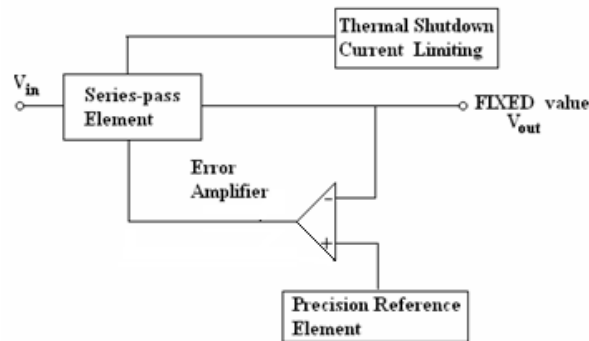
1. Low cost, highly reliable and small sized silicon diodes.
2. No centre tap is required in the transformer secondary so in case of a bridge rectifier the transformer required is simpler.
3. The PIV is one half that of centre-tap rectifier. Hence bridge rectifier is highly suited for high voltage applications.
4. Transformer utilization factor, in case of a bridge rectifier is higher than that of a centre tap transformer.

Disadvantages-

It needs four diodes, two of which conduct in alternate half cycles. Because of this the total voltage drop in diodes becomes double of that in case of centre tap rectifier.

Q.106 Draw the functional block diagram of Three-Terminal Voltage Regulator IC and describe its operation. **(5)**

Ans :

**Fundamental block diagram of a three terminal IC voltage regulator**

The latest generation of IC voltage regulators has devices with only three pins- one for the unregulated input voltage, one for regulated output voltage and one for ground.

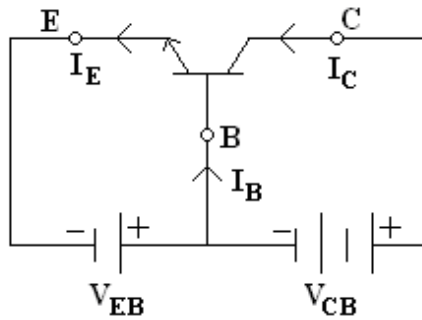
The error amplifier is used to maintain a constant voltage through a negative feedback.

The series pass element is driven by the output of the error amplifier. It acts as an automatically controlled variable resistor. Its resistance varies as required for maintaining the output voltage constant. The series pass element is typically a BJT that is rated to pass maximum load current.

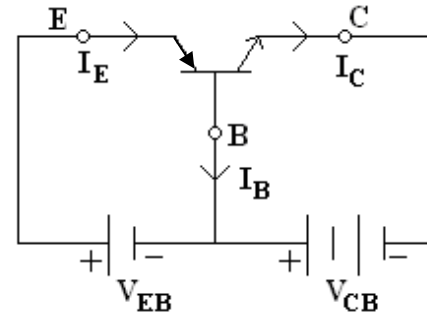
Q.107 Define a Transistor. Draw the circuit diagrams of p-n-p and n-p-n transistors with proper biasing voltages. Also indicate the reference directions for the currents and the reference polarities for the voltage. **(5)**

Ans :

The transistor is a solid state device whose operation depends upon the flow of electric charge carriers within the solid. The transistor is a current controlled device.



(a) NPN-transistor



(b) PNP-transistor

Q.108 Define Transistor characteristics? Sketch the output characteristics of a transistor in its CB mode. Explain the Active, cut-off and saturation Regions. (7)

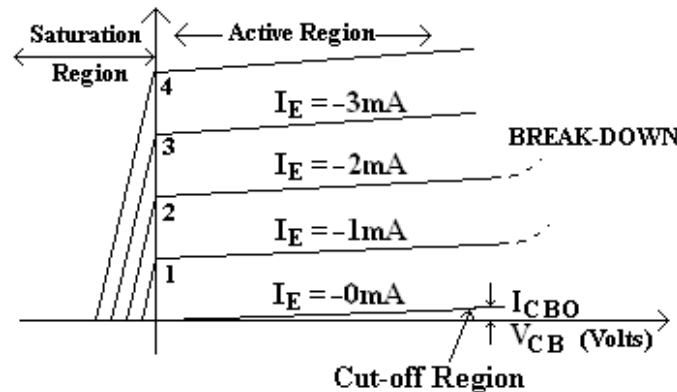
Ans :

The performance of transistors when connected in a circuit may be determined from their characteristic curves that relate different dc currents and voltage of a transistor. Such curves are known as static characteristic curves.

There are two important characteristics of transistor

1. Input characteristics,

2. Output characteristics.



Out put characteristics for Common Base NPN transistor

The curve drawn between collector current I_C and collector base voltage V_{CB} for a given value of emitter current I_E is known as output characteristics.

In an active region (emitter is forward biased and collector reverse biased) collector current I_C is almost equal to I_E and appears to remain constant when V_{CB} is increased. In fact, there is very small increase in I_C with increase in V_{CB} . This is because the increase in V_{CB} expands the collector base depletion region and thus shortens the distance between the two depletion regions.

In cut-off region (emitter and collector junctions both are reverse biased) small collector current I_C flows even when emitter current $I_E = 0$. This is the collector leakage current I_{CBO} or I_{CO} .

In saturation region (both emitter and collector junctions are forward biased) collector current I_C flows even when $V_{CB} \approx 0$.

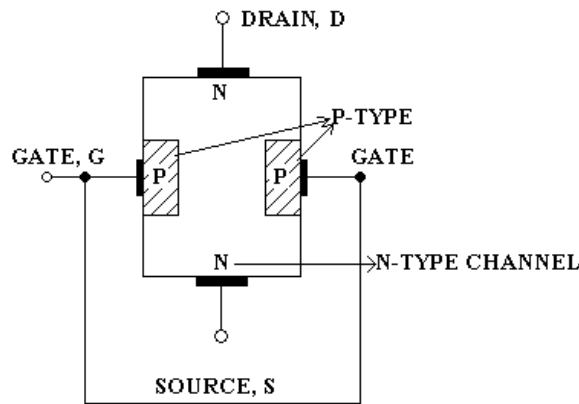
Q.109 What is MOSFET? Why MOSFETs are more widely used than the JFETs? (4)

Ans :

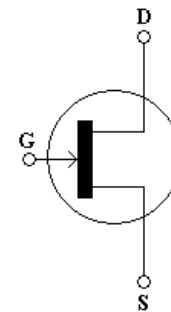
MOSFET – Metal Oxide Semiconductor Field Effect transistor is an important semiconductor device and is widely used in many circuit applications. MOSFET is a three terminal device (Source, Gate and Drain) and drain current in it is controlled by gate bias. These devices are more useful in electro meter applications than the JFETs. For the above reasons, and also because MOSFETs are easier to manufacture, they are widely used than JFETs.

Q.110 Draw the structure of an N-channel JFET and explain its principle of operation with neat diagrams along with V-I characteristics. Define Pinch-off voltage and mark it on the characteristics. Explain its significance in the operation of JFET. (8)

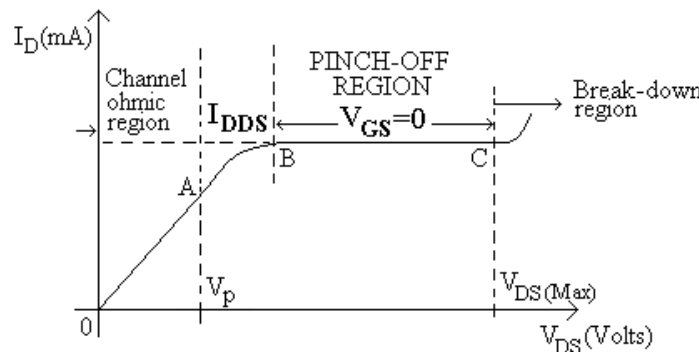
Ans :



(a) N-Channel JFET



Schematic symbol of N-Channel JFET



(b) JFET- Drain Characteristics with Shorted gate

Operation: When neither any bias is applied to the gate (i.e. When $V_{GS} = 0$) nor any voltage to the drain w.r.t. source (i.e. when $V_{DS} = 0$) the depletion regions around the P-N junctions are of equal thickness and symmetrical.

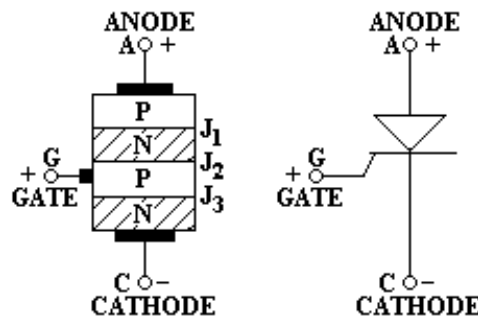
When positive voltage is applied to the drain terminal D w.r.t. source terminal S, without connecting gate terminal G to supply, the electrons (which are the majority carriers) flow from terminal S to terminal D, whereas conventional drain current I_D flows through the

channel from D to S. Due to flow of this current, there is a uniform voltage drop across the channel resistance as we move from terminal D to terminal S. This voltage drop reverse biases the diode. The gate is more negative w.r.t. to those points in the channel which are nearer to D to S. Hence, the depletion layers penetrate more deeply into the channel at points lying closer to D than to S. Hence the device is called the field effect transistor because the drain current is controlled by the effect of the extension of the field associated with the depletion region developed by the reverse bias at the gate.

- Q.111** What is an SCR? Explain the construction, working and V-I characteristics of an SCR for different gate currents and indicate there-upon holding current, latching current and break over voltage. (8)

Ans :

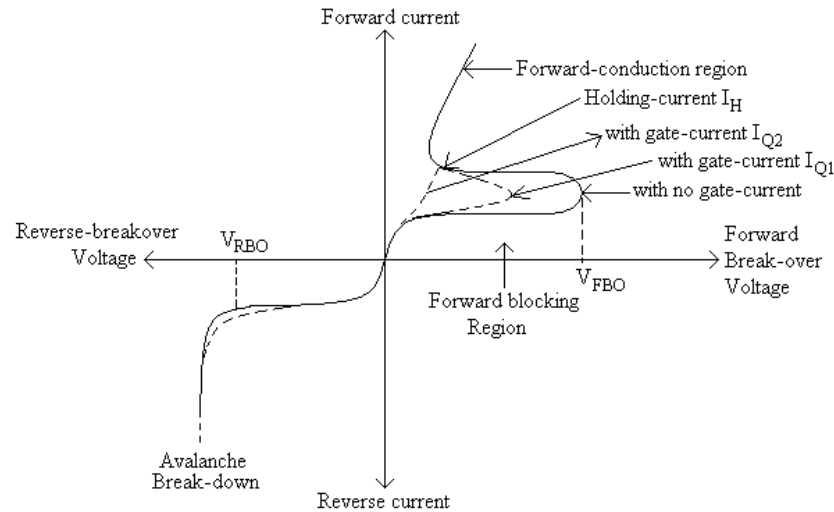
The SCR (Silicon controlled rectifier) is a controlled rectifier constructed of a silicon semiconductor material with a third terminal for control purposes. Silicon was chosen because of its high temperature and power capabilities. The third terminal gate, determines when the rectifier switches from the open circuit to short circuit state.



Schematic Diagram & Symbolic representation of SCR

Construction – SCR is essentially an ordinary rectifier (PN) and a junction transistor (NPN) combined in one unit to form PNPN device. It consists of a four layer pellet of P and N type silicon semiconductor materials. The junctions are diffused or alloyed. The material which may be used for P- diffusion is aluminium and for N diffusion is phosphorous. The contact with anode can be made with an aluminium foil through cathode and gate by metal sheet.

Working - SCR is a switch. Ideally it remains off or appears to have an infinite impedance until both the anode and gate terminals have suitable positive voltages with respect to the cathode terminal.



VI Characteristics of SCR

When anode is made positive w.r.t. the cathode, junction J_1 and J_3 are forward biased and junction J_2 is reverse biased and only the leakage current will flow through the device. The SCR is then said to be in the forward blocking state or in the forward mode or OFF state.

But when cathode is made positive w.r.t. the anode, junctions J_1 and J_3 are reverse biased a small reverse leakage current will flow through the SCR and the SCR is said to be in the reverse blocking or reverse mode.

When the SCR is in forward mode the SCR conducts when the forward voltage exceeds certain value called the forward breakover voltage V_{FBO} .

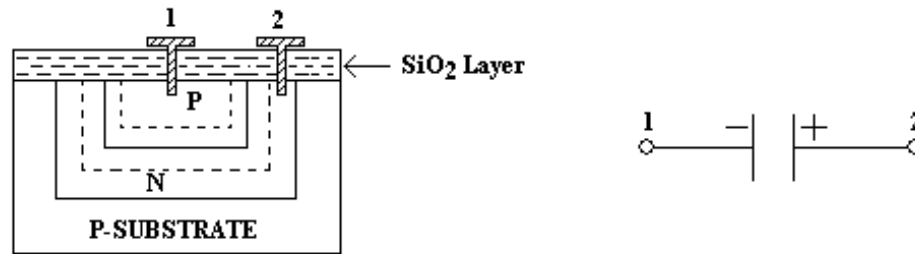
If a positive gate current is supplied, the SCR can become conducting at a voltage less than forward break over voltage. The larger the gate current, lower the break over voltage. With sufficiently large gate current the SCR behaves identical to PN rectifier.

Once the SCR has been switched ON, it has no control on the amount of current flowing through it. The current through the SCR is entirely controlled by the external impedance connected in the circuit and the supplied voltage. There is a very small about 1v, potential drop across the SCR. The forward current through the SCR can be reduced by reducing the applied voltage or by increasing circuit impedance. There is, however, a minimum forward current that must be maintained to keep the SCR in conducting state. This is called the **holding current** rating of SCR. If the current through the SCR is reduced below the level of holding current, the device returns to OFF state or blocking state.

Q.112 What is an integrated circuit? Explain how a capacitor can be constructed in a monolithic IC. (4)

Ans :

An integrated circuit (IC) consists of several interconnected transistors, resistors, capacitors, etc. all contained in one small package with external connecting terminals.



IC-Diffused capacitor

All P-N junctions have capacitance, so capacitors may be produced by fabricating suitable junctions. As shown in the above figure P and N regions form the capacitor plates and depletion region between them is the dielectric.

IC capacitors may also be fabricated by utilising the SiO₂ surface layer as a dielectric. A heavily doped N- region is diffused to form one plate of capacitor. The other plate is formed by depositing a film of aluminium on the SiO₂ formed on the wafer surface

Q.113 What is photo-electric emission? Explain how is this emission affected if the frequency and the intensity of the incident radiations are increased. (4)

Ans :

When the surface of certain alkaline material such as sodium, potassium, cesium or rubidium is illuminated by a beam of light or ultraviolet radiations, the electrons are emitted. The phenomenon is called photoelectric emission.

The work function of the alkaline materials is very low and therefore when energy of the ultraviolet radiations (called quanta) fall on the alkaline material, it gives sufficient energy to the free electrons of the material to speed up sufficiently to overcome the surface retaining forces of the metal and hence emission takes place. The electrons emitted in this way are called photo electrons. The number of electrons emitted depends upon the intensity (brightness) of light beam falling upon the emitter surface and the frequency of radiations.

The energy per bundle, is related to the frequency of light by $W=hf$ = quantum energy, where h is the Planck's constant and is equal to 6.626×10^{-34} Joules and f is the frequency in hertz. The energy required to liberate an electron = $e\Phi$ where e electronic charge = 1.602×10^{-19} and Φ = work function in electron volt. Hence for a photon to cause emission

$$hf \geq e\Phi ;$$

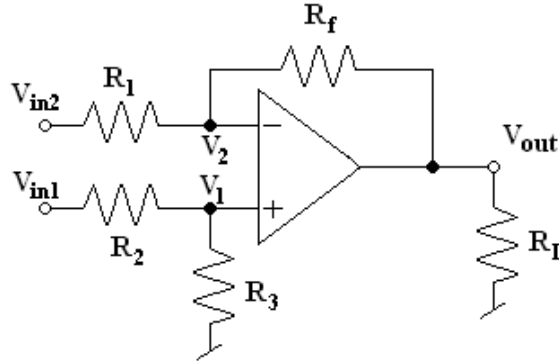
$$f \geq e\Phi / h$$

The minimum frequency which can cause photoemission is called the threshold frequency and is given by $f_0 = e\Phi / h$ and $f_0 = C/\lambda_0$;

$$\lambda_0 = C / f_0 = Ch / e\Phi$$

Q.114 Draw the circuit of an OP-AMP Differential Amplifier and derive an expression for its output voltage. (5)

Ans :



Sometimes it is necessary to amplify the voltage difference between two input lines neither of which is grounded. In this case the amplifier is called a differential amplifier.

Since circuit has two inputs V_{in1} and V_{in2} superposition theorem will be used for determination of voltage gain of the amplifier.

When $V_{in1} = 0$, then $V_{out} = \frac{-R_f}{R_1} \times V_{in2}$ (1)

When $V_{in2} = 0$, then $V_1 = \frac{R_3}{R_2 + R_3} \times V_{in2}$

And output due to V_{in1} then is

$$V_{out1} = \left(1 + \frac{R_f}{R_1}\right) V_1 = \left(1 + \frac{R_f}{R_1}\right) \left(\frac{R_3}{R_2 + R_3}\right) V_{in1}$$

If $R_1 = R_2$ and $R_f = R_3$

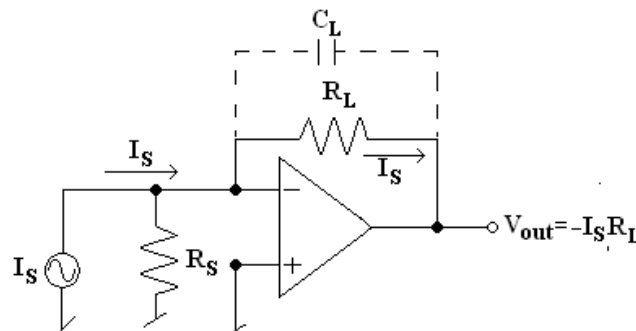
$\therefore V_{out1} = R_f/R_3 V_{in1}$ 2

The net o/p voltage, $V_{out} = V_{out1} + V_{out2}$

$$V_{out} = \frac{-R_f}{R_1} (V_{in2} - V_{in1})$$

Q.115 Explain the operation of an OPAMP current-to-voltage converter with the help of circuit diagram. (5)

Ans :



Current to voltage convert

DE05
DE06

ELECTRICAL ENGINEERING
BASIC ELECTRONICS

A device that produces a voltage proportional to input signal current is called a current to voltage converter. In this circuit a photocell or photo multiplier tube that provides output current is connected to the inverting terminal of the op-amp. R_s is the shunt source resistance.

$$V_{\text{out}} = -I_s R_L$$

Above equation indicating that the output voltage is directly proportional to the input current I_s . The capacitor is connected in parallel with resistor R_L for reducing the high frequency noise.

Q.116 Why are resistors, capacitors and inductors called passive components? Write a note on moulded-carbon composition resistor. How are active components are broadly classified?

(6)

Ans :

Passive components are those components which by themselves are not capable of amplifying or processing an electrical signal. This is the reason R, L and C is called passive components.

Carbon composition resistors- This is the most common type of low voltage resistor. The resistive material is of carbon clay composition and the leads are made of tinned copper. The resistor is enclosed in a plastic case to prevent the entry of moisture and other harmful elements from outside. These resistors have advantages of being cheap and reliable and their stability is high during their lifetimes, but are highly sensitive to temperature variations. The power-dissipating capacity of such units ranges from about 0.1 to 2 watts and the physical size is of the larger units have diameters less than 10mm.

Active components – are devices capable of amplifying or processing with the help of passive components. These active components can be broadly classified into two categories.

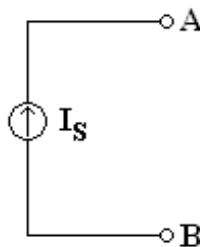
- 1) Tube Type – Vacuum tubes, Gas tubes
- 2) Semiconductor Devices – BJT, UJT, FET, SCR, Diode, etc.

Q.117 What do you mean by a constant current source? Write its symbolic representation. What is the symbol for a practical current source? Given an a.c. current source of strength 0.2A and impedance 100 ohms, write an equivalent voltage-source representation for this source.

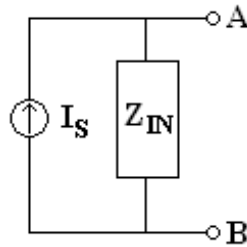
(8)

Ans :

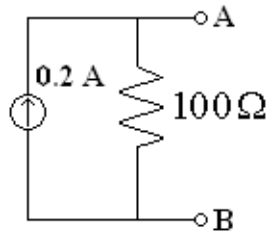
Constant current source – A source that supplies a constant current to a load even if its impedance varies.



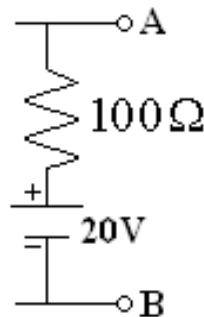
Symbolic representation of an Ideal-current source



Symbol for a practical current source



Open circuit voltage across terminals A and B is given as $V_{OC} = I_s R_{in} = 0.2 \times 100 = 20 \text{ V}$



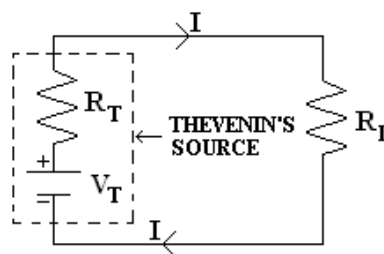
Equivalent-voltage source

Q.118 State Thevenin's theorem.

(2)

Ans :

Thevenin's theorem – provides a mathematical technique for replacing a two terminal network by a voltage source V_T and resistance R_T connected in series. The voltage source V_T is open circuit voltage that appears across the load terminals when the load is removed or disconnected and resistance R_T called the Thevenin's equivalent resistance is equal to the resistance of the network looking back into the loading terminals.



Thevenin's Equivalent Circuit

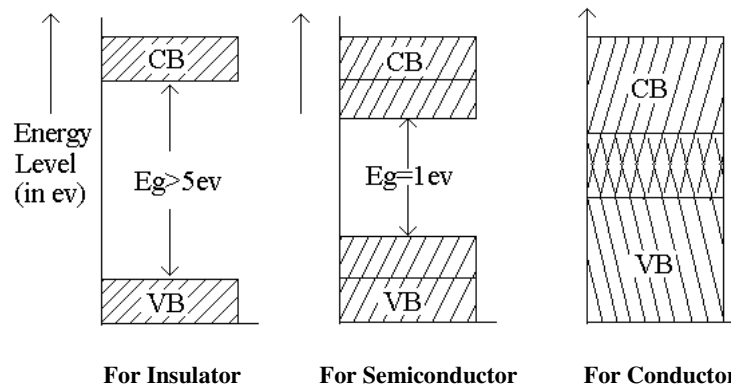
Where $I = \frac{V_T}{R_T + R_L}$ for dc network and $I = \frac{V_T}{Z_T + Z_L}$ for ac machines.

Q.119 What type of material can conduct electricity in it? Write the energy band diagrams for metals and insulators and briefly explain. **(8)**

Ans :

Conducting materials (such as silver, copper, aluminium etc.) are good conductors of electricity and are characterised by a large electrical conductivity and small electrical resistivity.

Within any given material there are two distinct energy bands in which electrons may exist. These two energy bands are valence band and conduction band and are separated by an energy gap in which no electrons normally exist. This energy gap is termed the Forbidden gap E_G .



The energy band of interest is the highest energy band or valence band. If a sufficient amount of energy is given to an electron in the valence band the electrons is freed of the atomic structure, such an electron is said to possess enough energy to be in conduction band , where it can take part in electric current flow. Free electrons can move readily under the influence of an external field.

Q.120 Briefly describe the effect of temperature on the conductivity of instrinsic semiconductors. **(3)**

Ans :

At absolute zero temperature, all the electrons of intrinsic semiconductors are tightly held by their atoms. The inner orbit electrons are bound to nucleus whereas, the valence electrons are bound by the forces of covalent bonds. Thus, at absolute zero temperature no free electron is available in the intrinsic semiconductor so it behaves like a perfect insulator.

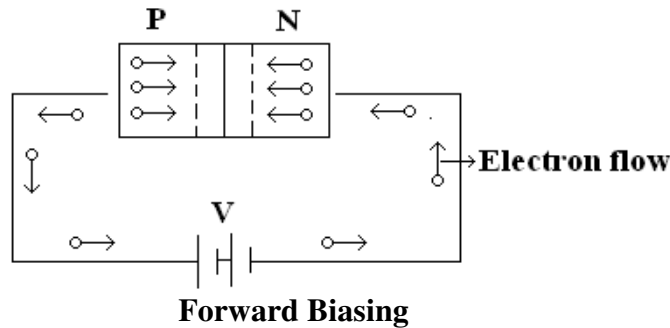
When the material is heated, electrons break away from their atoms and move from the valence band to conduction band. Thus produces holes in the valence band and free electrons in the conduction band. Conduction can then occur by electron movement and hole transfer. With the increase in temperature, the rate of generation of electron hole pairs is increased. This intrim increases the rate of recombination. Thus with the increase in temperature, the concentration of charge carriers increases. As more charge carriers are made available, the conductivity of a pure semiconductor increases with the increase in temperature.

DE05
DE06

ELECTRICAL ENGINEERING
BASIC ELECTRONICS

Q.121 Explain the operation of a PN-junction under forward bias condition. (5)

Ans :

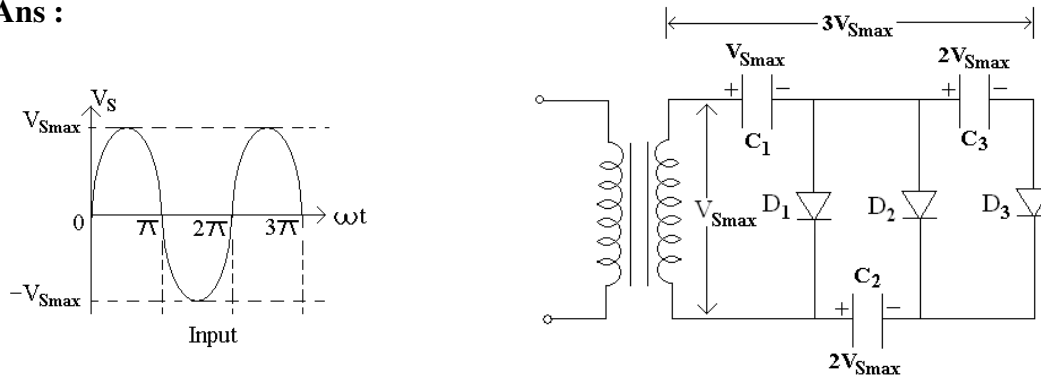


When an external field, with P-region connected to positive terminal and N-region connected to negative terminal of the battery, is applied across the junction, as shown in the figure, the junction is said to be forward biased.

After forward biased, barrier is reduced and it is eliminated altogether. The junction offers a low resistance called the forward resistance, r_f , to the flow of current and current flows in the circuit due to establishment of low resistance path and magnitude of current depends upon the magnitude of applied forward voltage.

Q.122 Explain the operation of a Voltage Tripler with a suitable diagram. (6)

Ans :



Voltage Tripler

In operation capacitor C_1 is charged through diode D_1 to a peak value of transformer secondary voltage V_{Smax} during first positive half cycle of the ac input voltage. During the negative half cycle capacitor C_2 is charged to twice the peak voltage $2 V_{Smax}$ developed by the sum of voltage across capacitor C_1 and transformer secondary winding. The voltage across capacitors C_1 and C_3 is $3 V_{Smax}$.

Q.123 Mention the effects of increasing the capacitance of a shunt capacitor filter on the performance of a rectifier. (3)

Ans :

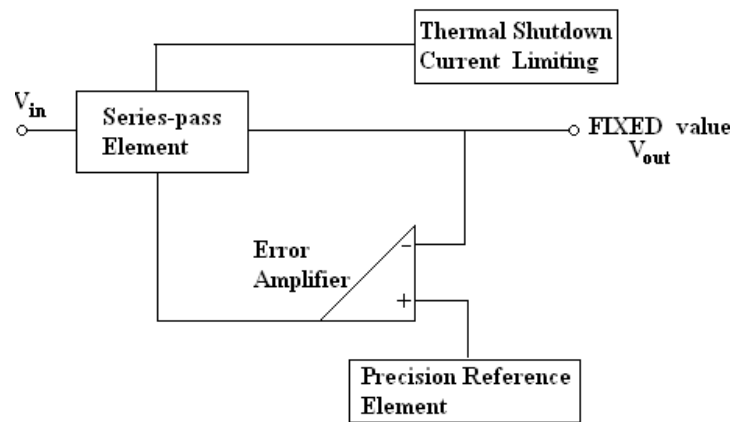
Larger the filter capacitor the more charge it can hold and less it will discharge. Hence the peak to peak value of the ripple will be less and the average dc level will increase.

But larger the capacitance value, greater is the current required to charge the capacitor to a given voltage.

Q.124 Why do the regulated supplies include current limiting? Name the building block of the first generation IC voltage regulators like the $\mu A723$. What is the disadvantage of these early IC regulators? (4)

Ans :

If the load resistance R_L is reduced or load terminals are shorted accidentally, a very large load current will flow in the circuit. It may destroy the pass transistor, diode or possible some other component. To avoid this situation a current limiting circuit is added.



Fundamental Block-Diagram of IC-Regulator

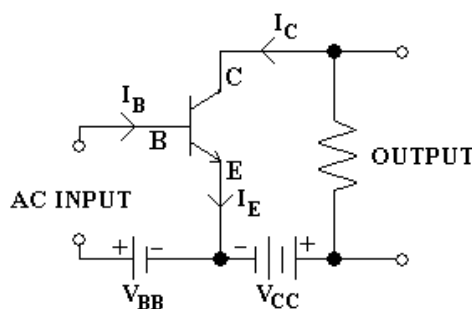
Series regulators are very popular of our needs. The main drawback of these regulators is the power dissipation in the pass transistor. Other drawbacks are regulated power supplies using these regulators require a step-down transformer and large sized filter capacitor to reduce the ripple.

Q.125 What is a transistor? Define a common-emitter configuration. Show that for a CE configuration $I_C = \beta_{dc} \cdot I_B + I_{CEO}$ with usual notations. (9)

Ans :

The transistor is a solid state device, whose operation depends upon the flow of electric charge carriers within the solid.

In common emitter configuration input is connected between base and emitter while the output is taken between collector and emitter.



Common emitter is commonly used because it's current, voltage and power gains are quite high and output to input impedance ratio is moderate.

The ratio of change in collector current and change in base current is called the base current amplification factor. i.e. $\beta = \Delta I_C / \Delta I_B$

$$\beta_{dc} = \frac{I_C}{I_B} = \frac{I_C}{I_E - I_C} = \frac{I_C / I_E}{1 - I_C / I_E} = \frac{\alpha_{dc}}{1 - \alpha_{dc}}$$

$$I_E = I_B + I_C \text{ and } I_C = \alpha I_E + I_{CBO} = \alpha(I_B + I_C) + I_{CBO}$$

$$I_C(1 - \alpha) = \alpha I_B + I_{CBO}$$

$$\text{or } I_C = \beta_{dc} I_B + I_{CBO}$$

$$\beta_{dc} = \frac{\alpha_{dc}}{1 - \alpha_{dc}} \text{ and } I_{CBO} = \frac{1}{1 - \alpha_{dc}} I_{CBO}$$

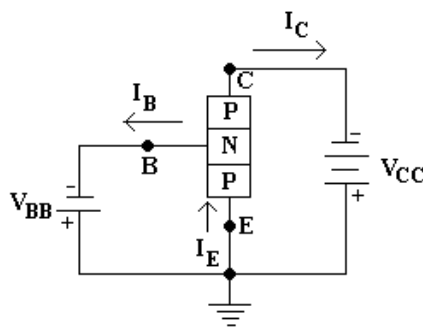
$$I_C = \beta_{dc} I_B + \frac{1}{1 - \alpha_{dc}} I_{CBO}$$

$$I_C = \beta_{dc} I_B + (\beta_{dc} + 1) I_{CBO}$$

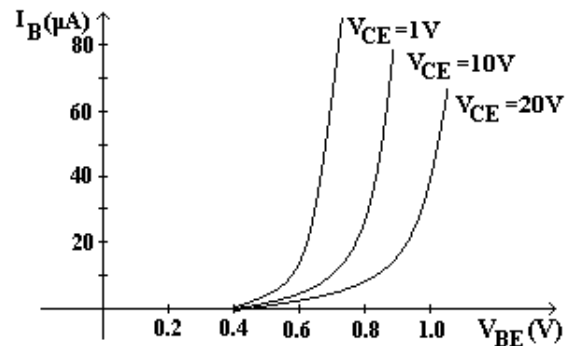
$$\therefore \frac{1}{1 - \alpha} = \beta + 1$$

Q.126 Write the input characteristics of a PNP transistor connected in common-emitter configuration. (3)

Ans :



CE-configuration: pnp transistor



CE-configuration: Input characteristics

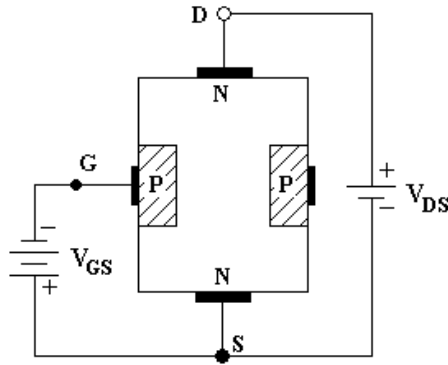
Q.127 What are the advantages of FETs over BJTs? Write the structure of an N-channel JFET. What do you mean by PINCH-OFF voltage of a JFET? (9)

Ans :

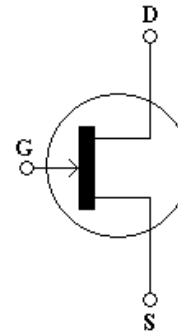
Advantages

1. FET's operation depends upon the flow of majority carriers only. It is therefore a unipolar device.
2. FET's are simpler to fabricate, smaller in size and has higher efficiency.

3. FET's have high input impedance($\cong 100\text{ M}\Omega$)
4. FET's are relatively immune to noise.
5. FET's have very high power gain and therefore the necessity of employing driver stage is eliminated.
6. FET's have negative temperature coefficient of resistance and therefore has better thermal stability.



N-Channel JFET



Schematic Symbol for N-Channel JFET

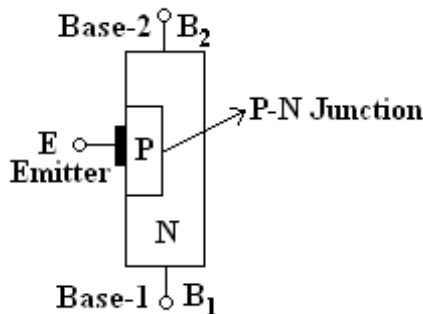
If the negative voltage at the gate is increased, depletion layers meet at the centre and the drain current I_D is cut-off completely. The gate to source voltage V_{GS} at which drain current I_D is cut-off completely, is called the PINCH-OFF voltage V_P .

Q.128 Write a brief note on UJT. (7)

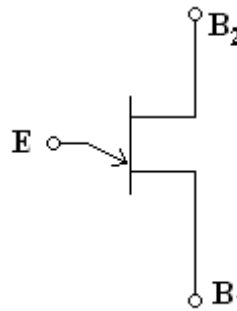
Ans :

Unijunction transistor is also called double base diode. It is a two layer, three terminal solid state switching device. This device has unique characteristic that when it is triggered its emitter current increases regeneratively until it is restricted by emitter power supply. It can be used in a wide variety of applications including oscillators, pulse generators, saw tooth generators, triggering circuits, phase control timing circuits and voltage or current regulated supplies.

The device has only one junction ie. one P-N junction, which is quite similar to a diode but it differs from an ordinary diode that it has three terminals.



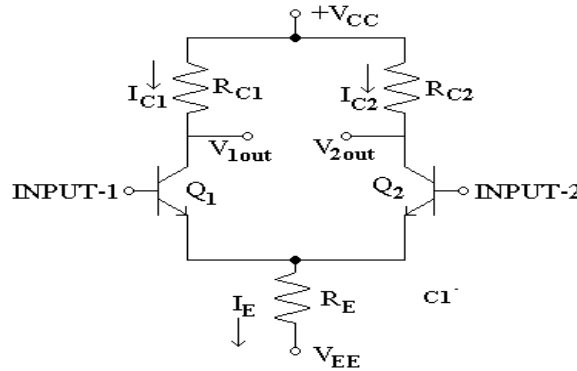
Base Structure (UJT)



Schematic Symbol (UJT)

Q.129 Write the circuit of the most general form of a differential amplifier using BJTs and briefly explain. (6)

Ans :



Differential Amplifier circuit

An amplifier which is designed to give the difference between the two input signals is called differential amplifier.

There are two inputs and two output as shown. When the input signal drives Q₁ there will be more voltage drop across R_{C1} and therefore, the collector of Q₁ will be less positive and when the input signal is negative it will turnoff the transistor and so voltage drop across R_{C1} will be negligible and collector of Q₁ will be more positive.

The amplifier can also be driven differentially by taking output between the collectors of Q₁ & Q₂. The advantage of the differential amplifier is that, hum and noise signal called common mode signal which is common to both inputs, is cancelled out in the output.

Q.130 Write the circuit of an OPAMP non-inverting voltage feedback amplifier and deduce the equation for its closed-loop gain. (6)

Ans :

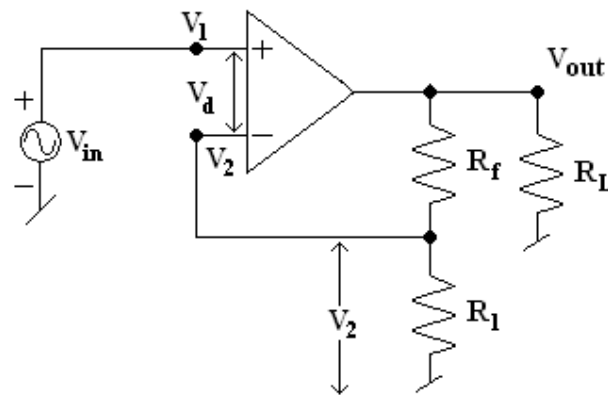
The closed loop gain

$$A_f = \frac{V_{out}}{V_{in}}$$

$$V_{out} = A(V_1 - V_2);$$

$$V_1 = V_{in}, V_2 = \frac{R_1}{R_1 + R_f} \times V_{out} = V_f$$

$$A_f = \frac{V_{out}}{V_{in}} = \frac{A(R_1 + R_f)}{R_1 + R_f + AR_1}$$



So $AR_1 \gg (R_1 + R_f)$ and $R_1 + R_f + AR_1 \approx AR_1$

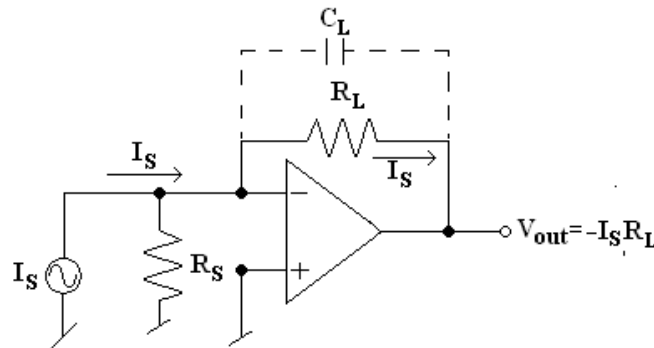
$$\text{Then } A_f = 1 + \frac{R_f}{R_1}$$

DE05
DE06

ELECTRICAL ENGINEERING
BASIC ELECTRONICS

Q.131 Write the circuit of a current-to-voltage converter using an OPAMP and explain its operation. (4)

Ans :



A device that produces a voltage proportional to input signal current is called a current to voltage converter. There is a virtual ground at the inverting input terminal, current flowing through R_S is zero, and, therefore, the entire input current I_S flows through the load resistor R_L resulting in the output voltage given as $V_{out} = -I_S R_L$. The above equation clearly indicates that the output voltage is directly proportional to the input current I_S .

Q.132 Define the following terms as used in IC fabrication:
(i) Chip (ii) Diffusion (iii) Etching. (4)

Ans :

(i) Chip - An integrated circuit IC is one in which all active and passive components are automatically part of a small semiconductor chip.

(ii) Diffusion - is the process of introduction of controlled amount of dopant atoms into the semiconductor. Diffusion alters the type of conductivity of the semiconductor. In silicon integrated circuit processing diffusion is used to form bases, emitters and resistors in bipolar technology and source and drain regions of MOSFET's in MOS technology. Commonly used diffusion methods are diffusion from a chemical source, diffusion from a doped oxide source.

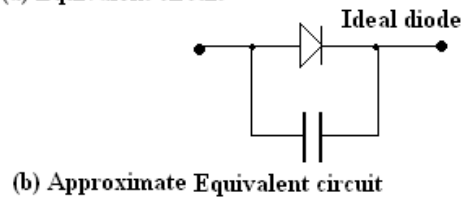
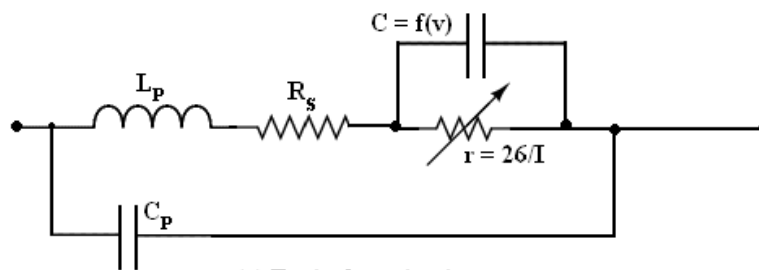
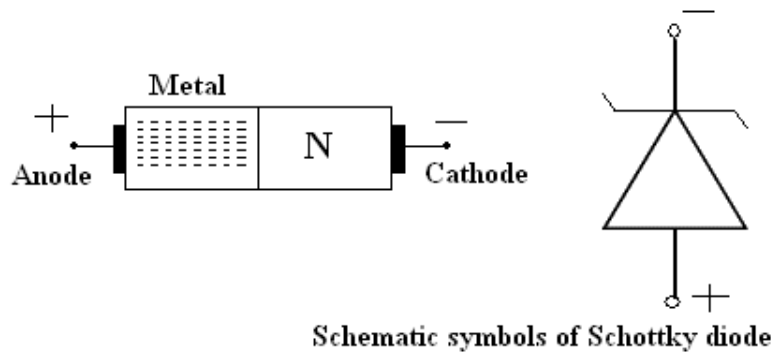
(iii) Etching - Selective removal of material in silicon IC process is known etching. The process may be chemical or physical. By physical means etching can be done by the kinetic energy associated with the bombarding ions in the ion stream or plasma. Etching can be classified as dry and wet etching. In case of dry-etching the wafer is bombarded by ions radicals or atoms in the vapour phase. In wet etching liquid chemicals are used.

Q.133 Briefly explain a Schottky diode. (4)

DE05
DE06

ELECTRICAL ENGINEERING
BASIC ELECTRONICS

Ans :



The reverse recovery time is short in small signal diodes that its effect cannot be noticed at frequencies below 10MHz or so. It becomes very important well above 10 MHz.

The solution is a special purpose device called a Schottky diode. Such a diode has no depletion layer eliminating the stored charges at the junction. Due to the lack of charge storage, the Schottky diode can switch off faster than ordinary diode. It's construction is very different from the normal PN junction in that a metal semiconductor junction is developed.

Q.134 What is an inductor? Explain briefly various types of fixed inductors employed in electronic industry. What is the role of variable inductors in radio receiver? (6)

Ans :

An inductor has been defined as a physical device which is capable of storing energy by virtue of a current flowing through it.

In case of an inductor current does not change instantaneously. It offers high impedance to ac but very low impedance to dc. It blocks ac signal but passes dc signal.

Inductors can be classified into filter chokes audio frequency chokes and radio frequency chokes.

Filter choke has many turns of fine wire wound on an iron core made of laminated sheets of E and I shapes and is used in smoothing the pulsating current produced by rectifying ac into dc.

Audio frequency chokes are used to provide high impedance to audio frequencies.

Radio frequency chokes are employed to block the radio frequency.

Variable inductors – Tuning circuits, phase shifting and switching of bands in amplifier sometimes require a variable inductance.

Q.135 Differentiate between a current source and a voltage source. Give their graphical representations. How can they be converted from one another? Determine the current flowing through 7Ω resistor in the circuit shown in Fig. 2 by using source transformation technique. **(10)**

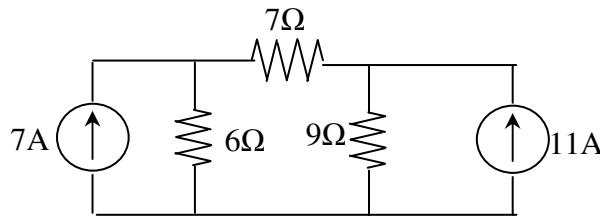
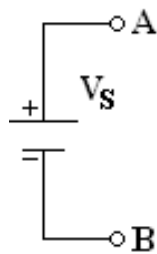


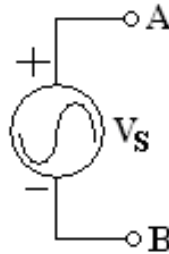
Fig 2

Ans :

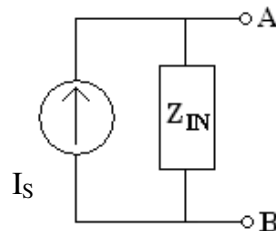
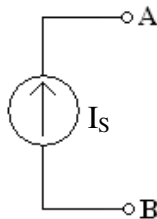
Any device that produces voltage output continuously is known as voltage source. It's basic purpose is to supply power to load connected across it.



Dc voltage source



ac voltage source



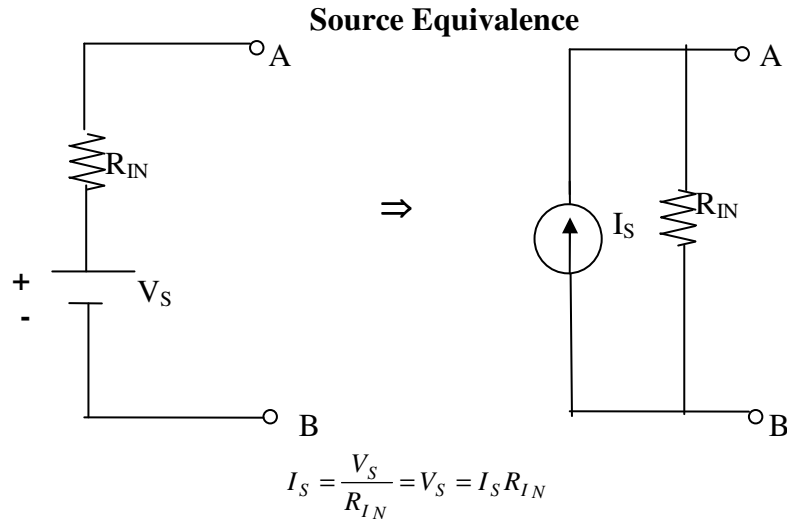
Ideal current source

Constant current source, a source that supplies a constant current to a load even if its impedance varies.

It should be noted that a voltage source series resistance combination is equivalent to a current source parallel resistance combination if, and only if their respective open circuit voltages are equal to respective short circuit currents are equal.

DE05
DE06

ELECTRICAL ENGINEERING
BASIC ELECTRONICS



- Q.136** “As regards conduction of current in concerned, a semiconductor is bipolar in nature whereas a metal is unipolar”-Justify (or) nullify the above statement. (7)

Ans :

In semiconductors both holes and electrons take part in conduction. This is the reason that these are bipolar in nature.

In conducting materials there is no forbidden gap. The orbits in the conduction band are very large. An electron in the conduction band experiences almost negligible nuclear attraction. In fact an electron in the conduction band does not belong to any particular atom but it moves randomly through out the solid.

- Q.137** Explain what do you understand by intrinsic, N-type and P-type semiconductors. Discuss the position of Fermi level in each case. (9)

Ans :

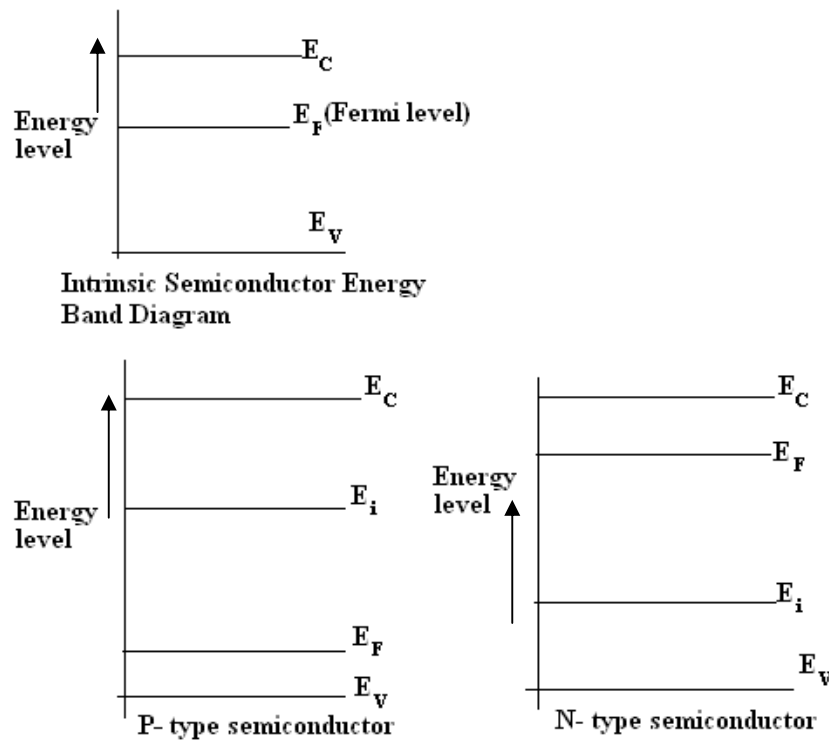
An intrinsic semiconductor is one which is made of the semiconductor material in its extremely pure form.

When a small amount of pentavalent impurity such as arsenic, antimony or phosphorous is added to a pure semiconductor crystal during crystal growth the resulting crystal is called the N-type extrinsic semiconductor.

When a small amount of trivalent impurity such as boron, gallium, indium or aluminium is added to a pure semiconductor crystal during the crystal growth, the resulting crystal is called the P-type extrinsic semiconductor.

DE05
DE06

ELECTRICAL ENGINEERING
BASIC ELECTRONICS



Q.138 Discuss the reasons for the existence of a depletion layer in a P-N junction. Relate it to the rectifying properties of a P-N junction. **(10)**

Ans :

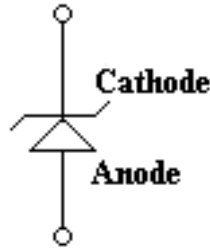
On the formation of P-N junction some of the holes from P-type material tend to diffuse across the boundary into N-type material and some of the free electrons similarly diffuse into the P-type material. This happens due to density gradient (as concentration of holes is higher on P-side than that on N-side and concentration of electrons is higher on N-side than that on P-side.) This process is known as diffusion.

As a result of the displacement of the charges, an electric field appears across the junction. Equilibrium is established when the field becomes large enough to restrain the process of diffusion. The electric charges are confined to the neighbourhood of the junction, and consists of immobile ions. The initial diffusion of charge carriers creates a barrier potential at the junction. The region around the junction is completely ionised. As a result there are no free electrons on the N-sides nor the holes on the P-side. Since the region around the junction is depleted of mobile charges it is called the depletion region, the space charge region or transition region.

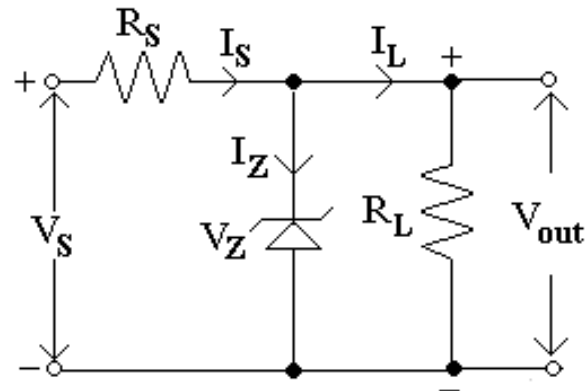
Q.139 What is a Zener diode? Explain, with the help of a circuit diagram. How Zener diode can be used as a voltage regulator? **(6)**

Ans :

Zener diode also sometimes called the breakdown diode is a P-N junction diode specially designed for operation in the breakdown region in reverse bias condition.



Zener diode symbol



Zener diode used as a Voltage regulator

Voltage regulation is a measure of a circuit's ability to maintain a constant output voltage even when either input voltage or load current varies.

A resistor R_S is necessary to limit the reverse current through the diode to a safer value. The voltage source V_S and resistor R_S are selected that the diode operates in the breakdown region. The diode voltage in this region which is also the voltage across the load R_L is called Zener Voltage V_Z and the diode current is called the Zener current I_Z .

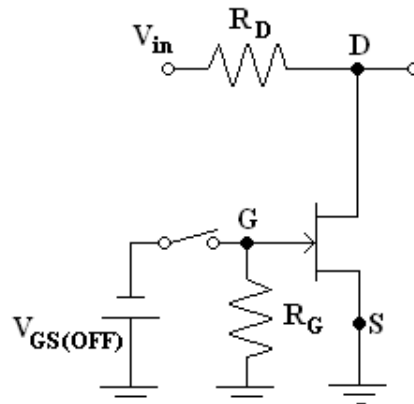
As long as voltage across the load resistor R_L is less than the breakdown voltage V_Z the zener diode does conduct. The resistors R_S and R_L constitute a potential divider across V_S . At an increased supply voltage V_S the voltage drop across load resistor becomes greater than the zener breakdown voltage. It then operates in the breakdown region. The series resistor R_S limits the zener current I_Z from exceeding its rated maximum value because

$$\text{zener current is given as } I_Z = \frac{V_S - V_Z}{R_S}, \text{ so } I_S = I_Z + I_L$$

When zener diode operates in its breakdown region the voltage across it V_Z remains fairly constant even though the current I_Z flowing through it may vary considerably.

Q.140 Explain the operation of JFET as an analog switch. (7)

Ans :



JFET as an Analog Switch

When no gate voltage is applied to the FET ie. $V_{GS} = 0$, FET becomes saturated and it behaves like a small resistance usually of the value of less than 100Ω and, therefore, output

$$\text{voltage becomes equal to } V_{OUT} = \frac{R_{DS}}{R_D + R_{DS}(ON)} V_{IN}$$

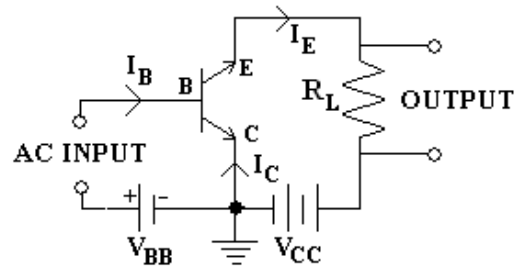
Since $R_D \gg R_{DS}(ON)$ so V_{OUT} can be taken equal to zero.. When a negative voltage equal to $V_{GS}(OFF)$ is applied to the gate, the FET operates in the cut-off region and it acts like a very high resistance usually of some mega ohms. Hence output voltage becomes nearly equal to input voltage.

- Q.141** Compare the characteristics of CB, CE and CC configurations of a transistor. Draw the circuit of a common collector transistor configuration and explain its operation. Also derive the relation between γ and α current amplification factors. (9)

Ans :

Characteristics	Common Base	Common Emitter	Common Collector
Input impedance	Low ($\cong 100\Omega$)	Medium ($\cong 800\Omega$)	Very high ($\cong 750k\Omega$)
Output impedance	Very high ($\cong 500k\Omega$)	High ($\cong 50k\Omega$)	Low ($\cong 50\Omega$)
Current gain	Less than unity	High ($\cong 80$)	High ($\cong 100$)
Voltage gain	About 150	$\cong 500$	Less than unity
Leakage current	$\cong 5\mu A$	Very large $\cong 500\mu A$	Very large

Common collector configuration



CC-NPN Transistor

In this arrangement base current I_B flows in the input circuit and emitter current I_E flows in the output circuit. So, change in emitter current ΔI_E to change in base current ΔI_B gives the current amplification factor γ

$$I_C = \alpha I_E + I_{CBO} \quad \text{and} \quad I_E = I_B + I_C$$

$$\therefore I_E = I_B + \alpha I_E + I_{CBO}$$

$$I_E(1 - \alpha) = I_B + I_{CBO}$$

$$I_E = \frac{I_B}{1-\alpha} + \frac{I_{CBO}}{1-\alpha} = (\beta+1)I_B + (\beta+1)I_{CBO}$$

$$\therefore \frac{1}{1-\alpha} = \beta+1$$

$$\text{Current gain } \gamma = \frac{\Delta I_E}{\Delta I_B} = \frac{\Delta I_E}{\Delta I_E - \Delta I_C}$$

$$\gamma = \frac{\frac{\Delta I_E}{\Delta I_C}}{\frac{\Delta I_E}{\Delta I_C} - 1} = \frac{1}{\frac{1}{\alpha} - 1} = \frac{1}{\frac{1-\alpha}{\alpha}} = \frac{\alpha}{1-\alpha} = \beta+1$$

This configuration primarily is used for impedance matching.

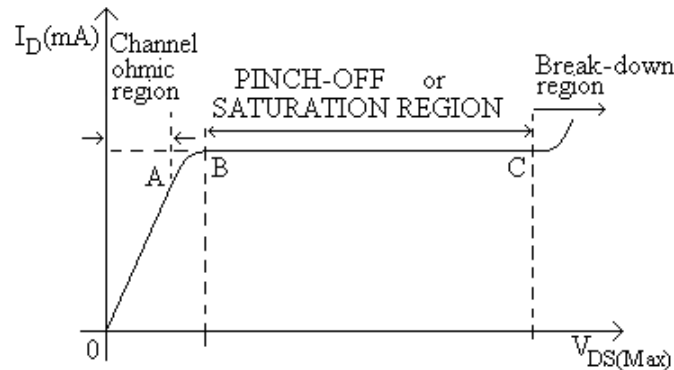
Q.142 Why are MOSFETs available in both enhancement and depletion modes, while JFETs operate almost invariably in the depletion modes. (4)

Ans :

In a JFET, if the gate is forward biased, excess carrier junction occurs and gate current is substantial. Thus channel conductance is enhanced to some degree due to excess carriers but device is never operated with gate forward biased because gate current is undesirable.

Q.143 Sketch the output characteristics for N-channel JFET with gate-source voltage shorted (i.e. $V_{GS}=0$). How Ohmic, Pinch-off and Breakdown regions are created? (8)

Ans :



JFET-Drain characteristic with Short-gate

Initially when V_{DS} is zero, there is no attracting potential at the drain, so no current flows in spite of the fact that the channel is fully open. Thus $I_D = 0$.

For small supply applied voltage V_{DS} , the N-type bar acts as a simple semiconductor resistor, and the drain current I_D increases linearly with the increase in V_{DS} , up to the knee point. This region of the curve is called the Channel Ohmic Region.

With the increase in drain current I_D , the ohmic voltage drop between the source and channel region reverse biases the gate junction. The reverse biasing of the gate junction is not uniform throughout. The reverse bias is more at the drain end than that at the source end of the channel, the conducting portion of the channel begins to constrict more at the drain

DE05
DE06

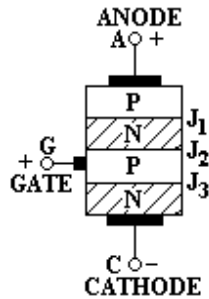
ELECTRICAL ENGINEERING
BASIC ELECTRONICS

end. Eventually a voltage V_{DS} is reached at which channel is pinched off, (ie. All the free charges from the channel gets removed), is called the Pinch-off voltage (V_P)

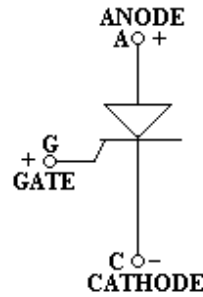
If V_{DS} is continuously increased, a stage comes when the gate channel junction breaks down. At this point the drain current increases very rapidly and the JFET may be destroyed. This is known as Avalanche Effect.

Q.144 Describe the structure, symbol and operation of SCR with the help of suitable diagrams. (8)

Ans :



Schematic Diagram



Symbolic Diagram

The SCR (Silicon controlled rectifier) is a controlled rectifier constructed of a silicon semiconductor material with a third terminal for control purposes. The basic operation of SCR is different from that of an ordinary two layer semiconductor diode in that, the third terminal gate determines when the rectifier switches from the open circuit to short circuit state. SCR device is a switch. Ideally it remains off or appears to have infinite impedance until both the anode and gate terminals have suitable positive voltages with respect to the cathode terminal. The thyristor then switches ON and current flows and continues to conduct without further gate signals.

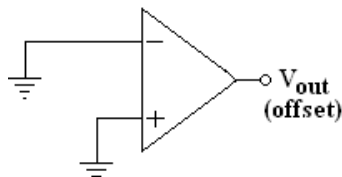
Q.145 Explain the following terms as referred to an operational amplifier

- (i) Input offset Voltage
- (ii) Input offset Current
- (iii) Slew Rate
- (vii) CMRR

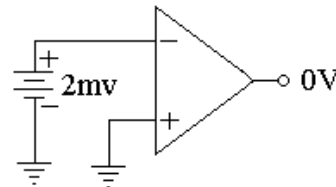
(12)

Ans :

(i) **Input offset Voltage**



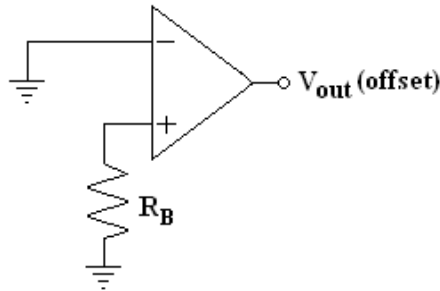
(a) Output offset voltage



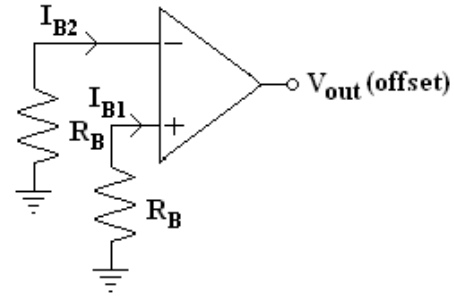
(b) Elimination of Output off-set voltage

When the inputs of the op-amp are grounded, there is almost always an output offset voltage as shown in fig(a) because the input transistors have different V_{BE} values.

(ii) Input offset current



(a) Output offset voltage due to Return-path resistance



(b) Reduced offset voltage by equal return resistors

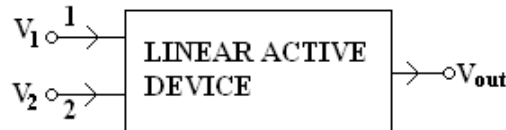
Input offset current $I_{in\ offset}$ – is defined as the difference between the two currents entering the input terminals of a balanced amplifier for $V_{OUT} = 0$
ie. $I_{in(Offset)} = I_{B1} - I_{B2}$ for $V_{OUT} = 0$

(iii) Slew Rate – The slew rate of an op-amp is defined as the maximum rate at which the output voltage can change, no matter how large an input signal applied.

$$SR = \left. \frac{d V_{OUT}}{dt} \right|_{Max}$$

This is usually measured in $V / \mu s$

(iv) CMRR- It is defined as the ratio of differential voltage gain to common mode voltage gain and it is given as $CMRR = A_d / A_{CM}$



If the differential amplifier is perfect, CMRR would be infinite because in that case common mode voltage gain A_{CM} would be zero.

$$CMRR_{(log)} = 20 \log(A_d / A_{CM}) \text{ and } V_{OUT} = A_d V_d \left(1 + \frac{1}{CMRR} \frac{V_{CM}}{V_d} \right)$$

PART – III

NUMERICALS

Q.1 A, power supply is having the following loads:-

Type of load	Max. demand (kW)	Diversity of group	Demand factor
Domestic	1500	1.2	0.8
Commercial	2000	1.1	0.9
Industrial	10,000	1.25	1

If the overall system diversity factor is 1.35, determine the maximum demand and connected load of each type. **(8)**

Ans:

The sum of maximum demands of three types of loads is = 1500 + 10,000 + 2000 = 13,500kW.

As the system diversity factor is 1.35,

Therefore, max. demand on the supply = $13,500 / 1.35 = 10,000 \text{ kW}$.

Each type of load has its own diversity factor among its consumers.

∴ connected domestic load = $1500 \times 1.2 / 0.8 = 2250 \text{ kW}$.

∴ connected commercial load = $2000 \times 1.1 / 0.9 = 2444 \text{ kW}$.

∴ connected domestic load = $10,000 \times 1.25 / 1 = 12,500 \text{ kW}$.

Q.2 A two-pole alternator runs at 3000 rpm and supplies power to a 10 –pole single – phase induction motor, which has full load slip of 5 %. Find the full load speed of the induction motor and the frequency of its rotor emf due to forward field. **(8)**

Ans:

$N_s = \frac{120 \times f}{p}$ where N_s = Synchronous speed and f = frequency of the supply voltage generated by the alternator, then

$$3000 = \frac{120 \times f}{2} = f = \frac{3000 \times 2}{120} = 50 \text{ Hz.}$$

$$N_s = \frac{120 \times 50}{10} = 600 \text{ rpm.}$$

$$s = \frac{N_s - N}{N_s} \text{ so, } 0.05 = \frac{600 - N}{600} = N = 570 \text{ rpm.}$$

If f_r is the rotor emf frequency, then $f_r = 50 \times 0.05 = 2.5 \text{ Hz}$.

Q.3 The voltage applied to a dc shunt motor is 220V. The armature current is 20A. The armature resistance is 0.5 Ω. The speed is 80 radians per second. Determine the induced emf, the electromagnetic torque and speed in rpm. **(8)**

Ans:

Given $V = 220 \text{ V}$, $I_a = 20 \text{ A}$ where I_a = the armature current. R_a = Armature resistance = 0.5 Ω and $\omega = 80 \text{ rad. /s}$.

The back emf of the motor $E_b = V - I_a R_a = 220 - 20 \times 0.5 = 210 \text{ V}$.

The electromagnetic torque $T_e = E_b I_a / \omega = 210 \times 20 / 80 = 52.5 \text{ N-m}$.

If N is the speed in rpm, then total angular distance covered in one minute = $2 \pi N$ radians.

Or angular distance covered in one second = $2 \pi N / 60 \text{ rad. / s}$

Hence $80 = 2 \pi N / 60$ or $N = \frac{80 \times 60}{2 \times 3.14} = 764 \text{ rpm}$.

Q.4 For the circuit shown in Fig.1, find the value of R_L for maximum power transfer. What will be the value of maximum power? **(8)**

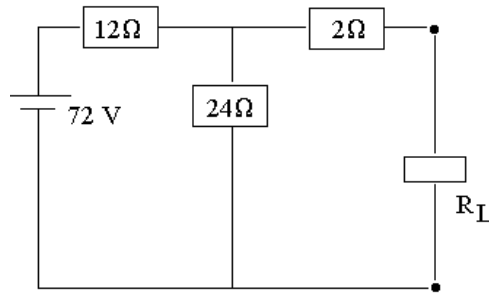


Fig.1

Ans:

Reduce the given circuit to Thevenin's circuit

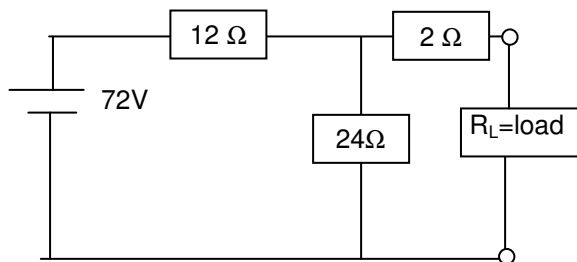


Fig. a

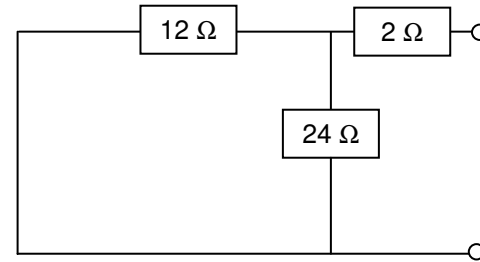


Fig. b

Remove the load resistance and replace battery by its internal resistance as shown in Fig d.

$$R_{th} = \frac{12 \times 24}{12 + 24} + 2 \Omega = 10 \Omega$$

Calculate $E_{th} = (72 \times 24) / (24+12) = 48 \text{ V}$ as shown in Fig c.

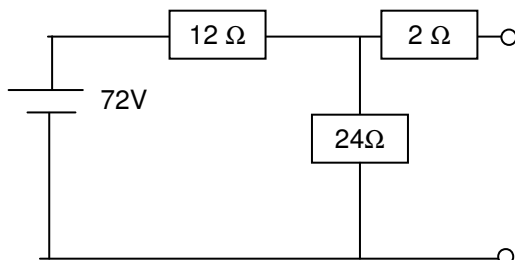


Fig.c.

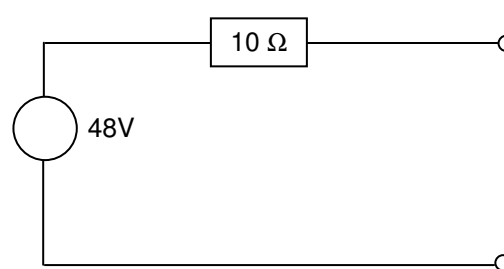


Fig.d.

For maximum power transfer the internal resistance of the source and load resistance should be equal. Hence load resistance of circuit is **10 Ω**. Maximum power = $E_{th}^2 / 4R_L = 48^2 / 4 \times 10 = 57.6 \text{ W}$.

DE05
DE06

ELECTRICAL ENGINEERING
BASIC ELECTRONICS

- Q.5** A series circuit of resistance 250Ω and inductance 0.25 H is excited from a pulse voltage of strength 10 V of duration 1 ms . Find the value of the current at 0.5 ms and 2 ms . (8)

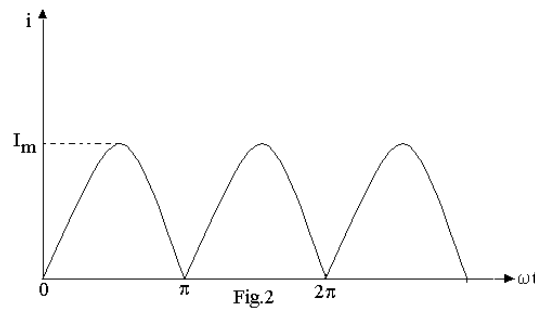
Ans:

$$e = E_m \sin \omega t ; E_m = 250\text{V and } 2\pi f = 2 \times 3.14 \times 50. \quad e = 250 \sin 314t$$

$$\text{When } e = 125\text{V then } \sin 314t = 125/250 = 0.5 ; 314t = \sin^{-1} 0.5 = 30^\circ$$

$$t = (30) / 100 \times 180^\circ = 1/600 = \mathbf{1.667\text{ms.}}$$

- Q.6** Find the average value of a full wave rectified sine wave shown in Fig.2. (4)



Ans:

$$\tau = L / R = 0.25 / 250 = 10^{-3} \text{ s}$$

Consider step voltage of strength 10 V . Response is given by

$$i(t) = 10 / 250 (1 - e^{-100t}) u(t)$$

$$10 P(t, 10^{-3}) = 10 u(t) - 10u(t - 10^{-3})$$

Pulse response is given by

$$i(t) = 0.04 (1 - e^{-100t}) u(t) - 0.04 (1 - e^{-100(t-10^{-3})}) u(t - 10^{-3})$$

$$t = 0.5 \text{ ms}$$

$$i(0.5 \times 10^{-3}) = 0.04 (1 - e^{-1000 \times 0.5 \times 10^{-3}}) - 0.04 (1 - e^{-0.5}) = \mathbf{0.0157 \text{ A}}$$

$$t = 0.5 \text{ ms}$$

$$i(2 \times 10^{-3}) = 0.04 (1 - e^{-1000 \times 2 \times 10^{-3}}) - 0.04 (1 - e^{-1000(2-1)10^{-3}})$$

$$= 0.04 (1 - e^{-2}) - 0.04 (1 - e^{-1}) = \mathbf{0.0093 \text{ A}}$$

- Q.7** The electric mains in a house is marked as 230 V , 50 Hz . Write down the equation for instantaneous voltage in sinusoidal form. (4)

Ans:

$$V_{\text{rms}} = 230\text{V}; f = 50\text{Hz } V_{\text{max}} = \sqrt{2} \times V_{\text{rms}} = 325.22 \text{ V}$$

$$\omega = 2\pi f = 2 \times 3.14 \times 50$$

$$\text{Hence } e = \mathbf{325.22 \sin 314 t}$$

DE05
DE06ELECTRICAL ENGINEERING
BASIC ELECTRONICS

- Q.8** The secondary of a 750 KVA, 11000/ 400 V, 50 Hz transformer has 160 turns. Determine the primary number of turns, primary and secondary full load current neglecting losses. If the area of cross section of the core is 100 cm^2 , what will be flux density in the core? **(8)**

Ans:

$$\frac{N_2}{N_1} = \frac{V_2}{V_1} \text{ where } N_2 \text{ and } N_1 \text{ are the number of turns on the secondary and primary windings.}$$

$$N_1 = \frac{V_1 N_2}{V_2} = \frac{11000 \times 160}{400} = 4400 \text{ turns. } \mathbf{N_1 = 4400 \text{ turns.}}$$

$$I_1 V_1 = 750 \times 1000 = \therefore I_1 = \frac{750 \times 1000}{11000} = \mathbf{68.182 \text{ A.}}$$

$$I_2 V_2 = 750 \times 1000 = \therefore I_2 = \frac{750 \times 1000}{400} = \mathbf{1875 \text{ A.}}$$

$$E_1 = 4.44 \phi_{\max} f N_1 \text{ volts} = \phi_{\max} = \frac{11000}{4.44 \times 50 \times 4400} = \mathbf{0.01126 \text{ Wb.}}$$

$$\therefore B_{\max} = \frac{0.01126}{100 \times 10^{-4}} = 1.126 \text{ Wb/m}^2$$

$$\therefore B_{\max} = \mathbf{1.126 \text{ Wb/m}^2}.$$

- Q.9** A 3 – phase transformer consisting of three 1 – phase transformers each with turn ratio of 10:1 (primary : secondary) is used to supply a 3 – phase load of 120 kVA at 400 V on the secondary side. Calculate the primary line current and voltage if the transformer is connected (i) Δ/Y (ii) Y/Δ . What is the line-line transformation ratio in each case? **(8)**

Ans:

$$\Delta/Y \text{ connection} - I = (120 \times 1000) / \sqrt{3} \times 400 = \mathbf{173.2 \text{ A}}$$

$$\text{Primary line-to line voltage} = a V / \sqrt{3} = 10 \times 400 / \sqrt{3} = \mathbf{2309 \text{ V}}; \text{ where } a = \text{turns ratio}$$

$$\text{Primary line current} = \sqrt{3} \times I / a = 1.732 \times 173.2 \times 1/10 = \mathbf{30 \text{ A}};$$

$$\text{Line to line transformation ratio} = a V / \sqrt{3} / V = a / \sqrt{3} = \mathbf{10 / \sqrt{3}}$$

$$Y/\Delta = \text{Primary line-to line voltage} = \sqrt{3} a V = \sqrt{3} \times 10 \times 400 = \mathbf{6928 \text{ V}};$$

$$\text{Primary line current} = 173.2 / \sqrt{3} = 10 \times 1.732 = \mathbf{10 \text{ A}};$$

$$\text{Line to line transformation ratio} = \mathbf{10 \sqrt{3}}$$

- Q.10** A separately excited dc motor is operating at an armature voltage of 300 V. It's no-load speed is 1200 rpm. When fully loaded it delivers a motor torque of 350 N-m and its speed drops to 1100 rpm. What is the full load current and power? What is the armature resistance of the motor? The motor is now fed with an armature voltage of 600 V, while its excitation is held fixed as before. If it is once again fully loaded, find the motor torque, power and speed. **(8)**

Ans:

$$\text{Given } E_a = V = 300 \text{ V, } 300 = (K_a \times \Phi \times 2 \pi \times 1200) / 60 \text{ or } K_a \times \Phi = 2.39$$

$$E_a = (300 \times 1100) / 1200 = 275 \text{ V.}$$

$$K_a = Z P / 2 \pi \times A \text{ is a constant.}$$

DE05
DE06

ELECTRICAL ENGINEERING
BASIC ELECTRONICS

$I_a = 350/2.39 = 146.4$ A where I_a = the armature current.
 Mechanical power developed = $E_a I_a = 275 \times 146.7 = \mathbf{40.3$ KW.
 $R_a = (300 - 275) / 146.4 = \mathbf{0.171\Omega}$
 Armature voltage = 600V
 $I_a = 350/2.39 = 146.4$ A; $T = 350$ N-m
 The back emf of the motor $E_b = V - I_a R_a = 600 - 146.4 \times 0.171 = \mathbf{575$ V.
 $575 = 2.39 \times 2 \pi n / 60$; $n = \mathbf{2297}$ rpm.
 Power = $E_a R_a = 575 \times 146.4 = \mathbf{84.2}$ kW

- Q.11** A coil, which has 10Ω resistance and 50mH inductance is connected to 230V, 50Hz supply. Calculate the current in the coil. (5)

Ans:

$$X_L = 2 \times 3.14 \times 50 \times 50 \times 10^{-3} = 15.7 \Omega$$

$$\therefore Z = \sqrt{(10)^2 + (15.7)^2} = \sqrt{(100) + (246.5)} = 18.6\Omega.$$

$$\therefore I = \frac{230}{18.6} = 12.37A.$$

$I = \mathbf{12.37A}.$

- Q.12** A 3-phase induction motor which is wound for 4-poles, when running on full load, develops a useful torque of 100 Nm; also the rotor emf is observed to make 120-cycles/ min. It is known that the torque lost on account of friction and core loss is 7 Nm. Calculate the shaft power output, rotor copper loss, motor input and motor efficiency. (8)

Ans:

$$f_2 = sf ; 120 / 60 = 2 \text{ Hz where } f_2 = \text{rotor frequency}$$

$$s(\text{slip}) = 2.5 / 50 = 0.04$$

$$n_s (\text{synchronous speed}) = 1500 \text{ rpm}$$

$$n = (1 - 0.04) \times 1500 = 1440 \text{ rpm}$$

$$\omega = 2 \pi \times 1440 / 60 = 150.7 \text{ rad/s}$$

$$\text{Shaft power output} = 100 \times 150.7 = \mathbf{15.07 \text{ KW.}}$$

$$P_m = (100 + 7) \times 150.7 = 16.12 \text{ kW.}$$

$$\text{Rotor copper loss} = 3 I_2^2 R_2 = P_m (s / 1 - s) = 16.12 \times 0.04 / (1 - 0.04) = \mathbf{0.67 \text{ kW}}$$

$$\text{Motor input} = 16.12 + 0.67 + 0.7 = \mathbf{17.49 \text{ kW.}}$$

$$\eta = 15.07 / 17.49 = \mathbf{86.16 \%}$$

- Q.13** When a coil is connected to a 230V, 50Hz supply, it takes a current of 2A and the power consumption is 150W. Calculate the resistance and inductance of the coil. (5)

Ans:

$$Z = \frac{V}{I} \text{ Where } Z \text{ is the impedance, } V \text{ is the voltage and } I \text{ the current.}$$

$$\therefore Z = \frac{230}{2} = 115\Omega. \text{ And } P = I^2 R; \therefore R = \frac{P}{I^2} = \frac{150}{2^2} = \mathbf{37.5 \Omega.}$$

$$\therefore X_L = \sqrt{(115)^2 - (37.5)^2}$$

$$X_L = \sqrt{(13225) - (1406.25)} = X_L = \sqrt{11818.75} = 108.71\Omega.$$

DE05
DE06

ELECTRICAL ENGINEERING
BASIC ELECTRONICS

$$\text{Or } L = \frac{108.71}{2 \times 3.14 \times 50} = \mathbf{0.346 \text{ H.}}$$

- Q.14** Three non-inductive resistances of 5Ω , 20Ω , and 25Ω are connected in delta. Obtain its equivalent star connected system maintaining the same phase sequence. **(8)**

Ans:

Star equivalent of delta connection can be calculated by using the following expressions

$$R_A = \frac{R_{AB}R_{CA}}{R_{AB} + R_{BC} + R_{CA}}$$

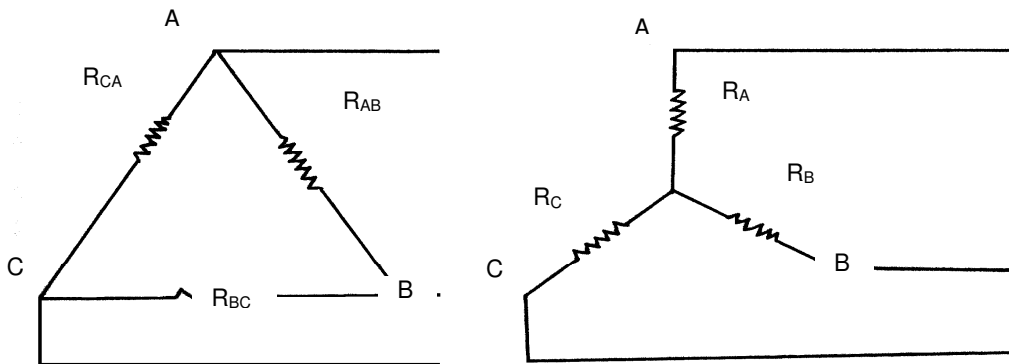
$$R_B = \frac{R_{BC}R_{AB}}{R_{AB} + R_{BC} + R_{CA}}$$

$$R_C = \frac{R_{CA}R_{BC}}{R_{AB} + R_{BC} + R_{CA}}$$

$$R_A = \frac{5 \times 25}{5 + 20 + 25} = \frac{125}{50} = \mathbf{2.5 \Omega}$$

$$R_B = \frac{5 \times 20}{5 + 20 + 25} = \frac{100}{50} = \mathbf{2 \Omega}$$

$$R_C = \frac{25 \times 20}{5 + 20 + 25} = \frac{500}{50} = \mathbf{10 \Omega}$$



- Q.15** A power station has a load cycle as under: 260 MW for 6 hr; 200MW for 8 hr; 160 MW for 4hr; 100MW for 6hr. If the power station is equipped with 4 sets of 75 MW each. Calculate the load factor and capacity factor from the above data. **(8)**

Ans:

$$\text{Daily load factor} = \frac{\text{Units actually supplied in a day}}{\text{Max. Demand} \times 24}$$

$$\text{MWh supplied per day} = (260 \times 6) + (200 \times 8) + (160 \times 4) + (100 \times 6) = 4,400$$

$$\therefore \text{Station daily load factor} = \frac{4,400}{260 \times 24} = \mathbf{0.704 \text{ or } 70.4 \%}$$

DE05
DE06ELECTRICAL ENGINEERING
BASIC ELECTRONICS

$$\text{Capacity factor} = \frac{\text{Average demand on station}}{\text{Installed capacity of the station}}$$

No. of MWh supplied per day = 4,400 \therefore Average power / day = 4,400/24 MW.

Total installed capacity of the station = 75 X 4 = 300 MW.

$$\text{Capacity factor} = \frac{4,400/24}{300} = \mathbf{0.611 \text{ or } 61.1 \%}$$

- Q.16** A generating station has a maximum demand of 25 MW, a load factor of 60%, a plant capacity factor of 50% and a plant use factor of 72%. Find
- the daily energy produced
 - reserve capacity of the plant,
 - the maximum energy that could be produced daily, if the plant, while running as per schedule, were fully loaded.
- (8)**

Ans:

$$\text{Load factor} = \text{Average demand} / \text{Max. demand} = 0.6 = \text{Average demand} / 25$$

Average demand = **15 MW**.

$$\text{Plant capacity factor} = \text{average demand} / \text{installed capacity} = 0.50 = 15 / \text{installed capacity}$$

$$\text{Installed capacity} = 15 / 0.5 = \mathbf{30 \text{ MW}}$$

$$\begin{aligned} \text{Therefore reserve capacity of the plant} &= \text{installed capacity} - \text{Maximum demand} \\ &= 30 - 25 = \mathbf{5 \text{ MW}}. \end{aligned}$$

$$\text{Daily energy produced} = \text{average demand} \times 24 = 15 \times 24 = \mathbf{360 \text{ MWh}}$$

$$\text{Energy corresponding to installed capacity per day} = 24 \times 30 = \mathbf{720 \text{ MWh}}$$

$$\begin{aligned} \text{Maximum energy that could be produced} &= \text{actual energy produced in a day} / \text{plant use factor} = \\ &= 360 / 0.72 = \mathbf{500 \text{ MWh} / \text{day}}. \end{aligned}$$

- Q.17** A 3-phase induction motor is wound for 4-poles and is supplied from a 50 Hz system. Calculate
- synchronous speed.
 - actual speed of the motor when running at 4 % slip.
 - frequency of emf induced in rotor.
- (6)**

Ans:

$$\begin{aligned} \text{Synchronous speed, } N_s &= \frac{120 \times f}{P} = \frac{120 \times 50}{4} = \mathbf{1500 \text{ r.p.m.}} \text{ Where } f \text{ is the supply frequency.} \\ &\text{and } P \text{ is the No. of poles.} \end{aligned}$$

$$\text{Actual Speed of motor} = N = N_s (1-S) \text{ Where } S \text{ is the slip} = 0.04$$

$$\therefore N = 1500 (1 - 0.04) = \mathbf{1440 \text{ r.p.m.}}$$

$$\text{Frequency of the rotor emf} = f_r = S f = 0.04 \times 50 = \mathbf{2 \text{ Hz}}.$$

DE05
DE06

ELECTRICAL ENGINEERING
BASIC ELECTRONICS

- Q.18** Calculate the maximum power by a solar cell at an intensity of 200 W/m^2 . Given $V_{\text{max}} = 0.14 \text{ V}$ and $I_{\text{max}} = -6 \text{ mA}$. Also calculate the cell efficiency if the area is 4 cm^2 . (8)

Ans:

For solar cell maximum power $P_{\text{max}} = I_{\text{max}} V_{\text{max}}$

$$P_{\text{max}}(\text{output}) = -6 \times 10^{-3} \times 0.14 = -0.84 \text{ mW}$$

$$= -0.84 \times 10^{-3} \text{ W}$$

$$P_{\text{input}} = \text{intensity} \times \text{area} = 200 \times 4 \times 10^{-4}$$

$$\text{Cell } \eta = (0.84 \times 10^{-3}) / (200 \times 4 \times 10^{-4}) = \mathbf{1.05 \%}$$

- Q.19** A 6- pole lap wound shunt motor has 500 conductors in the armature. The resistance of the armature path is 0.05Ω . The resistance of shunt field is 25Ω . Find the speed of the motor when it takes 120 A from the dc mains of 100 V supply. Flux per pole is $2 \times 10^{-2} \text{ wb}$. (8)

Ans:

$I_{\text{sh}} = V_{\text{sh}} / R_{\text{sh}} = 100 / 25 = 4 \text{ A}$. Where I_{sh} is the shunt field current, V_{sh} is the shunt field voltage and R_{sh} is the resistance of the shunt field.

$I_a = I_L - I_{\text{sh}} = 120 - 4 = 116 \text{ A}$. Where I_L the line current and I_a is the armature current.

$E_b = V - I_a R_a$ where V is the applied voltage and E_b is back emf developed.

$$= 100 - 116 \times 0.05 = 94.2 \text{ V.}$$

$$E_b = P \phi Z N / 60 \text{ A} = 94.2 = \frac{6 \times 2 \times 10(-2) \times 500 \times N}{60 \times 6} \text{ where } Z = \text{No. of conductors}$$

$$60 \times 6$$

$$P = \text{No. of poles} : \phi = \text{flux per pole.}$$

$\therefore N = \text{Speed of the motor is } \mathbf{565.2 \text{ r.p.m.}}$

- Q.20** Using Thevenin's theorem, find the current through 2.5 ohms resistance in the circuit shown in the FIG-1 (10)

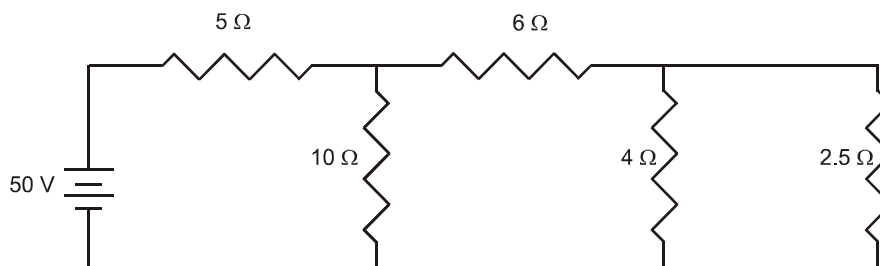


FIG - 1

Ans:

According to Thevenin's theorem

(i) Remove the load resistance (2.5 ohm) from the circuit as shown in the fig 2b.

(ii) In fig 2b, the total resistance across the emf source is given as

$$R_1 = \frac{(6+4) \times 10}{(6+4)+10} + 5 = 10 \Omega$$

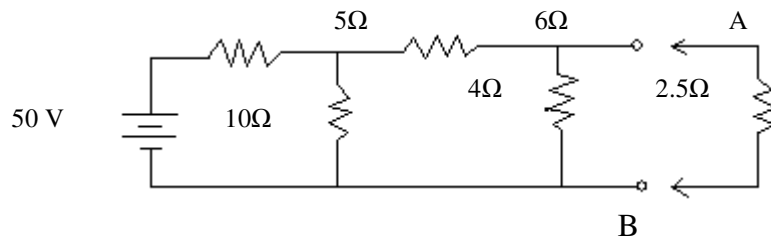


Fig 2(b)

- Current drawn from battery $I = 50/10 = 5A$
 Current flowing through 4Ω resistance $= 5 \times \{10/10+(6+4)\} = 2.5A$
 Voltage across open circuited point AB $V_{th} = 4 \times 2.5 = 10V$

- (iii) Now replace the emf source by its zero internal resistance as shown in fig 2c and calculating equivalent resistance between point AB

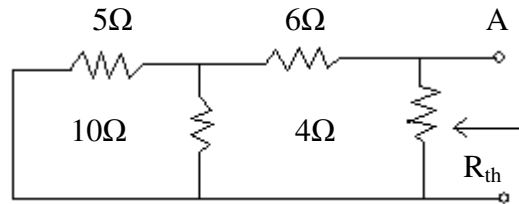


Fig 2(c)

$$R_{th} = \{(5 \times 10)/(5+10)\} + 6 \parallel 4$$

$$= (50/15) + 6 \parallel 4$$

$$= (9.33 \times 4)/(9.33+4) = 2.8\Omega$$

- (iv) Now the Thevenin's equivalent circuit may be drawn as shown in fig 2d connecting 2.5Ω resistance across AB and calculating current flowing through 2.5Ω resistance as $I_L = 10/(2.8+2.5) = 1.886A$

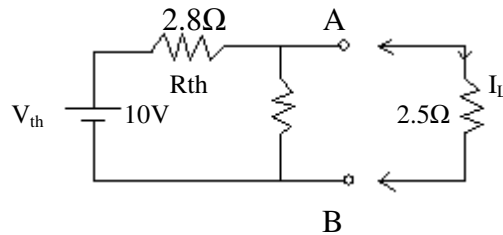


Fig 2(d)

- Q.21** In a 25 kVA, 2000 / 200V transformer the iron and full load copper losses are 350W and 400W respectively. Calculate the efficiency at unity power factor at
 (i) full load and (ii) half load. **(10)**

DE05
DE06ELECTRICAL ENGINEERING
BASIC ELECTRONICS**Ans:**

$$\eta_x = \frac{x \text{ kVA} \times 1000 \times \cos \phi}{x \text{ kVA} \times 1000 \times \cos \phi + P_i + x^2 P_c}$$

Where $\cos \phi = 1$ and $P_i = \text{iron loss} = 350 \text{ W}$; $P_c = \text{copper loss} = 400 \text{ W}$.

(i) At full load $x = 1$

$$\therefore \eta = \frac{1 \times 25 \times 1000 \times 1}{1 \times 25 \times 1000 \times 1 + 350 + 1 \times 1 \times 400} \times 100 = \mathbf{97.087 \%}$$

(ii) At half load $x = 0.5$

$$\therefore \eta = \frac{0.5 \times 25 \times 1000 \times 1}{0.5 \times 25 \times 1000 \times 1 + 350 + 0.5 \times 0.5 \times 400} \times 100 = \mathbf{96.525 \%}$$

Q.22 An a.c circuit consists of a pure resistance of 10 ohms and is connected across an a.c supply of 230V, 50 Hz.

Determine (i) current flowing through the circuit.

(ii) Power consumed by the circuit.

(iii) Write down the equation for voltage and current. **(8)**

Ans:

i) Current in the circuit, $I = V/R = 230/10 = \mathbf{23A}$

ii) Power consumed by the circuit $P = VI$
 $= 230 \times 23 = \mathbf{5290 \text{ W}}$

iii) Maximum value of applied voltage $V_m = \sqrt{2}V_{rms} = \sqrt{2} \times 230 = 325.27V$

Maximum value of current $I_m = \sqrt{2}I_{rms} = \sqrt{2} \times 23 = 32.53A$

Angular velocity $\omega = 2\pi f = 314 \text{ rad/s}$

Equation for applied voltage $v = V_m \sin \omega t = 325.27 \sin 314t$

As in pure resistive circuit, current and voltage are in phase with each other, therefore equation for current is

$$i = I_m \sin \omega t = 32.53 \sin 314t$$

Q.23 Find the impedance, current and power factor of the following series circuits and draw the corresponding phasor diagrams i) R and L ii) R and C iii) R, L and C. In each case the applied voltage is 200volts and the frequency is 50Hz. $R = 10 \Omega$, $L = 50 \text{ mH}$, $C = 100 \mu\text{F}$.

(16)**Ans:**

Inductive reactance, $X_L = 2\pi f L = 2\pi \times 50 \times 50 \times 10^{-3} = 15.7 \Omega$

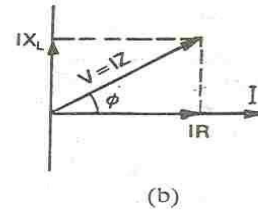
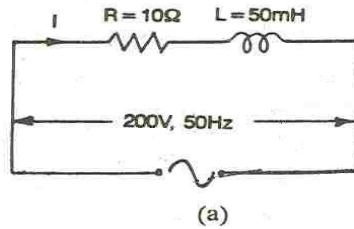
Capacitive reactance $X_C = 1/2\pi f C = 1/2\pi \times 50 \times 100 \times 10^{-6} = 31.83 \Omega$

(i) When R and L are in series as shown in fig. (a)

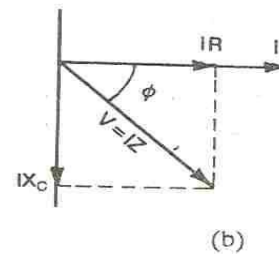
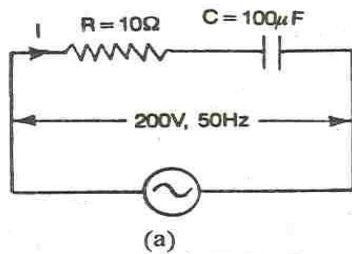
DE05
DE06

ELECTRICAL ENGINEERING
BASIC ELECTRONICS

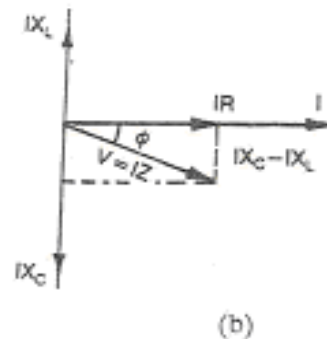
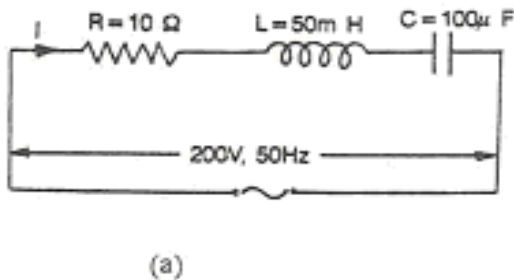
Impedance $Z = \sqrt{R^2 + X_L^2} = \sqrt{(10)^2 + (15.7)^2} = 18.61 \Omega$
 Current, $I = V / Z = 200 / 18.61 = 10.74 \text{ A}$
 Power factor $\cos \phi = R / Z = 10 / 18.61 = 0.5373 \text{ lag.}$
 The phasor diagram is shown in fig. (b)



(ii) When R and C are in series as shown in fig. (a)
 Impedance $Z = \sqrt{R^2 + X_C^2} = \sqrt{(10)^2 + (31.83)^2} = 33.36 \Omega$
 Current, $I = V / Z = 200 / 33.36 = 6 \text{ A}$
 Power factor $\cos \phi = R / Z = 10 / 33.36 = 0.2997 \text{ leading.}$
 The phasor diagram is shown in fig. (b).



(iii) When R, L and C are in series as shown in fig. (a)
 Impedance $Z = \sqrt{R^2 + (X_C - X_L)^2} = \sqrt{(10)^2 + (31.83 - 15.7)^2} = 18.98 \Omega$
 Current, $I = V / Z = 200 / 18.98 = 10.54 \text{ A}$
 Power factor $\cos \phi = R / Z = 10 / 18.98 = 0.5259 \text{ leading.}$
 The phasor diagram is shown in fig. (b).



DE05
DE06

ELECTRICAL ENGINEERING
BASIC ELECTRONICS

- Q.24** The armature of a 4-pole, d.c shunt motor has a lap-connected armature winding with 740 conductors. The no load flux per pole is 30 mwb. If the armature current is 40A, determine the torque developed? **(8)**

Ans:

Torque developed in a DC motor is given by

$$T_a = 0.159 \Phi Z I_a (P/A) N.m$$

Here $Z = 740$

$$P = 4$$

$$I_a = 40A$$

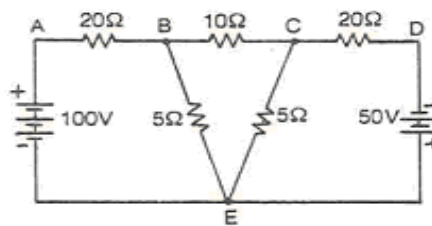
$A = 4$ (for lap connected winding $A = P$)

$$\Phi = 30mwb = 30 \times 10^{-3} wb$$

$$T_a = 0.159 \times 30 \times 10^{-3} \times 740 \times 40 \times (4/4) N.m$$

$$= 141.14 Nm$$

- Q.25** For the circuit shown find the current in various branches by nodal analysis. **(8)**



Ans:

The independent nodes are B, C and E. Let E be, the reference node and V_B and V_C be the voltages at nodes B and C respectively. The current flowing through various branches are as shown in fig.(b). At node B, $I_1 = I_2 + I_4$

$$\frac{100 - V_B}{20} = \frac{V_B - V_C}{10} + \frac{V_B}{5}$$

$$\text{Or } V_B \{1/20 + 1/10 + 1/5\} - 100/20 - V_C/10 = 0 \text{ -----(1)}$$

$$\text{Or } 7 V_B - 2 V_C - 100 = 0$$

At node C, $I_2 = I_3 + I_5$

$$\frac{V_B - V_C}{10} = \frac{V_C + 50}{20} + \frac{V_C}{5}$$

$$\text{Or } V_C \{1/10 + 1/20 + 1/5\} + 50/20 - V_B/10 = 0 \text{ -----(2)}$$

$$\text{Or } 7 V_C - 2 V_B + 50 = 0$$

Solving equations (1) and (2) $V_B = 40/3 V = 13.33 V$ and $V_C = -10/3 V = -3.33V$

$$\therefore I_1 = \frac{100 - V_B}{20} = 4.33 A \text{ from A to B}$$

$$I_2 = \frac{V_B - V_C}{10} = 1.67 A \text{ from B to C}$$

$$I_3 = \frac{V_C + 50}{20} = 4.67 A \text{ from C to D}$$

$$I_4 = \frac{V_B}{5} = 2.67 A \text{ from B to E}$$

$$I_5 = V_C = -0.67 A \text{ from E to C}$$

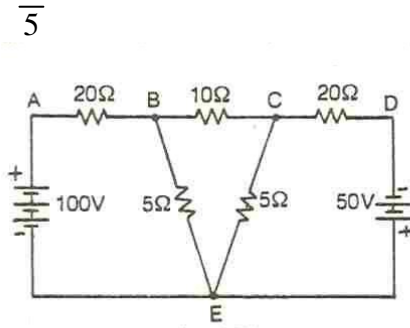
DE05
DE06ELECTRICAL ENGINEERING
BASIC ELECTRONICS

Fig.(a)

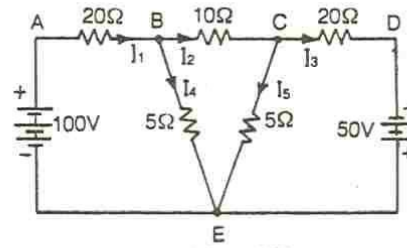


Fig.(b)

- Q.26** A power station has a maximum demand of 15000kW. The annual load factor is 50% and capacity factor is 40%. Determine the reserve capacity of the plant. (6)

Ans:

Energy generated / annum = Max. Demand X Load factor X Hours in a year.
 $= 15000 \times 0.5 \times 8760 = 65.7 \times 10^6 \text{ kWh.}$

Capacity factor = $\frac{\text{Units generated/ annum}}{\text{Plant capacity/ Hours in a year}} = \frac{65.7 \times 10^6}{0.4 \times 8760} = 18,750 \text{ kW.}$

Reserve capacity = Plant capacity – Max. Demand. = 18,750 – 15,000 = 3750 kW.

- Q.27** A 100 MW power station delivers 100MW for 2 hours, 50 MW for 6 hours and is shut down for rest of each day. It is also shut down for maintenance for 45 days each year. Calculate its annual load factor. (8)

Ans:

Energy supplied for each working day = (100 x 2) + (50 x 6) = 500 MWh.

Station operates for 365 – 45 = 320 days in a year.

Energy supplied / year = 500 x 320 = 160,000 MWh.

Annual load factor = $\frac{\text{MWh supplied per annum}}{\text{Max. demand in MW} \times \text{working hours}} \times 100$
 $= \frac{160,000}{100 \times 320 \times 24} \times 100 = 20.8\%$

- Q.28** A 3-phase induction motor has 6-poles and runs at 960 rpm on full load. It is supplied from an alternator having 4 poles and running at 1500 rpm. Calculate the full load slip of the motor. (6)

Ans:

No. of poles of the alternator = 4

Speed of the alternator = 1500 rpm.

Therefore frequency $f = \frac{N \times P}{120} = \frac{1500 \times 4}{120} = 50 \text{ Hz}$

DE05
DE06

ELECTRICAL ENGINEERING
BASIC ELECTRONICS

Therefore frequency generated by the alternator = 50 Hz.

Induction motor has 6 poles (P).

Speed N of the motor = 960 rpm.

Supply frequency of the alternator is 50 Hz.

Synchronous speed of the motor $N_s = \frac{120 \times 50}{P} = \frac{120 \times 50}{6} = 1000$ rpm.

$$\% \text{ Slip } S = \frac{N_s - N}{N_s} \times 100 = \frac{1000 - 960}{1000} \times 100 = 4 \%$$

Q.29 A 3-Phase induction motor is wound for 4-poles and is supplied from a 50 Hz system.

Calculate

(i) Synchronous speed

(ii) The speed of the rotor when the slip is 4%

(iii) The rotor frequency when the rotor runs at 1200 rpm. (6)

Ans:

(i)

$$N_s = 120f / p = 120 \times 50 / 4 \\ = \mathbf{1500 \text{ r.p.m}}$$

(ii)

$$\% \text{age slips} = \frac{(N_s - N) \times 100}{N_s}$$

$$4 = \frac{(1500 - N) \times 100}{1500}$$

$$N = \mathbf{1400 \text{ rpm}}$$

(iii)

The slip, when N = 1200 rpm

$$s = \frac{1500 - 1200}{1500}$$

$$= 0.2$$

Therefore, rotor frequency $f' = s.f = 0.2 \times 50 = \mathbf{10 \text{ Hz}}$.

Q.30 A 25 KVA transformer has 500 turns on the primary and 40 turns on the secondary. If the primary is connected to a 3000V, 50 Hz mains, calculate (i) the primary and secondary currents at full load, (ii) the secondary e.m.f. and (iii) maximum flux in the core. (8)

Ans:

At full load the current in the primary winding $I_1 = \frac{25 \times 10^3}{3000} = \mathbf{8.33 \text{ A}}$.

$$\frac{I_1}{I_2} = \frac{E_2}{E_1} = \frac{N_2}{N_1}$$

$$I_2 = \frac{N_2}{N_1} \times I_1 = \frac{500}{40} \times 8.33 = \mathbf{104.15 \text{ A}}$$
 is the current in the secondary winding.

N_1 and N_2 are the number of turns in the primary and secondary windings.

E_1 and E_2 are the emfs of the primary and secondary windings.

DE05
DE06ELECTRICAL ENGINEERING
BASIC ELECTRONICS

$$E_2 = \frac{N_2}{N_1} \times E_1 = \frac{40}{500} \times 3000 = \mathbf{240 \text{ V.}}$$

Using the relation

$E_1 = 4.44 N_1 f \phi_m = 3000 = 4.44 \times 500 \times 50 \times \phi_m$; where ϕ_m is the maximum flux and f is the frequency.

$$\phi_m = \mathbf{0.027 \text{ wb.}}$$

- Q.31** If a generating station has a maximum load for the year of 18,000 kW and a load factor of 30.5% and the maximum loads on the substations were 7500 kW, 5000 kW, 3400 kW, 4600 kW and 2800 kW. Calculate the units generated for the year and diversity factor of the generating station. **(8)**

Ans:

$$\text{Load factor} = \frac{\text{Average power}}{\text{Maximum demand}}$$

$$0.305 = \frac{\text{Average power}}{18000}$$

$$\text{Average power} = 18000 \times .305 = \mathbf{5490 \text{ kW}}$$

$$\text{No. of hr/year} = 36 \times 24 = \mathbf{8760 \text{ hr}}$$

$$\text{No. of units generated/yr} = 5490 \times 8760 = \mathbf{48,092,400 \text{ kWh}}$$

$$\text{Diversity factor} = \frac{\text{Sum of the individual max. demand}}{\text{Max. demand of the whole yr.}}$$

$$\text{Sum of the individual max. demand} = 7500 + 5000 + 3400 + 4600 + 2800 = \mathbf{23,300 \text{ kW}}$$

$$\text{Max. load} = \mathbf{18000 \text{ kW}}$$

$$\text{Therefore, Diversity factor} = \frac{23,300}{18000} = \mathbf{1.3 \text{ approx.}}$$

- Q.32** A 230 V, 1150RPM, 4-pole, DC shunt motor has a total of 620 conductors arranged in two parallel paths, and yielding an armature circuit resistance of 0.2 Ω . When it delivers rated power at rated speed, it draws a line current of 74.8 A, and a field current of 3A. Calculate the flux per pole, torque developed, armature and field copper losses. **(8)**

Ans:

$$I_a \text{ (armature current)} = I_L \text{ (load current)} - I_{sh} \text{ (shunt field current).}$$

$$I_a = 74.8 - 3 = 71.8 \text{ A.}$$

$$E_b \text{ (back emf)} = V \text{ (supply voltage)} - I_a R_a. \text{ Where } R_a \text{ is the armature resistance.}$$

$$E_b = 230 - 71.8 \times 0.2 = \mathbf{215.64 \text{ V.}}$$

$$E_b = \frac{\phi Z N P}{60 A} \text{ where } Z \text{ is the number of conductors, } N \text{ is the speed in rpm, } P \text{ the no. of poles.}$$

$$\phi = \frac{60 \times 2 \times 215.64}{620 \times 1150 \times 4} = \mathbf{9.073 \text{ mwb.}}$$

DE05
DE06ELECTRICAL ENGINEERING
BASIC ELECTRONICS

$$T_a(\text{torque}) = 0.159 \times P \times I_a \times \phi \times Z = 0.159 \times 4 \times 71.8 \times 9.073 \times 10^{-3} \times 620 = \mathbf{133.8 \text{ N-m.}}$$

$$\text{Armature copper losses} = I_a^2 R_a = (71.8)^2 \times 0.2 = \mathbf{1031 \text{ W.}}$$

$$\text{Field copper losses} = I_{sh}^2 R_{sh} = I_{sh} V_{sh} = 3 \times 230 = 690 \text{ W.}$$

- Q.33** For the circuit shown in Fig.1, find the current in the load resistance $R_L=18\Omega$ and the voltage across it by Norton's theorem and verify the result by applying Thevenin's Theorem. **(8)**

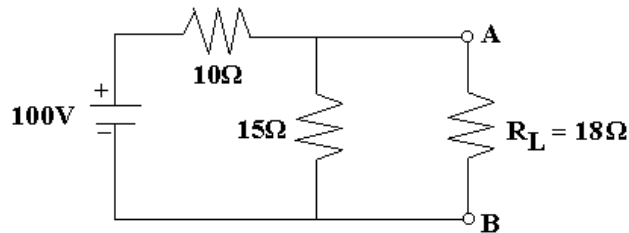


Fig.1

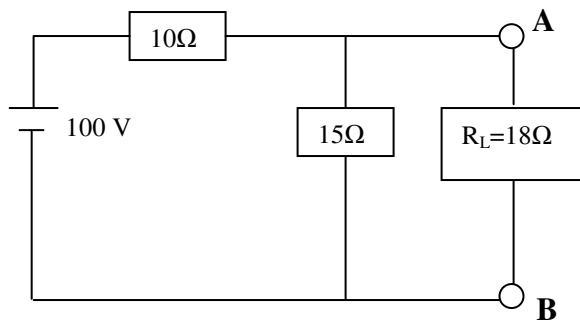
Ans:

Fig. a

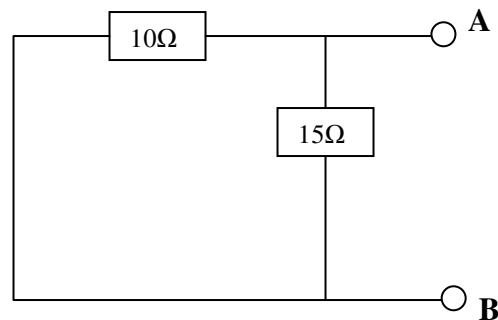


Fig. b

Remove the load resistance and replace 100V battery by its internal resistance as shown in fig.b.

$$R_{\text{Nort}} \text{ or } R_{\text{th}} = \frac{10 \times 15}{10 + 15} = 6\Omega$$

For calculation of the value of current, remove load from A and B and short these terminals. New circuit will be as shown in fig.c.

DE05
DE06

ELECTRICAL ENGINEERING
BASIC ELECTRONICS

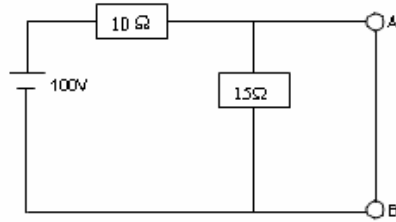


Fig. c

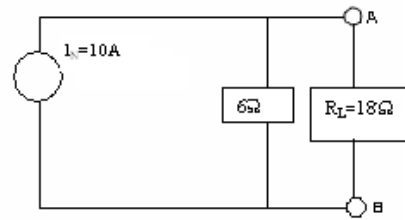


Fig. d

$$I = \frac{100}{10} = 10A$$

Now final circuit will be as shown in fig.d

So $V_{AB} = 10 \times$ Total resistance of 6Ω and 18Ω

$$= 10 \times \frac{6 \times 18}{6 + 18} = 10 \times 4.5 = 45 \text{Volts.}$$

$$I_L = \frac{45}{18} = 2.5A$$

By applying Thevenin's theorem, $R_{th} = \frac{10 \times 15}{10 + 15} = \frac{150}{25} = 6\Omega$.

For calculating E_{th} (Thevenin's voltage), remove load and redraw the circuit as shown in fig.e.

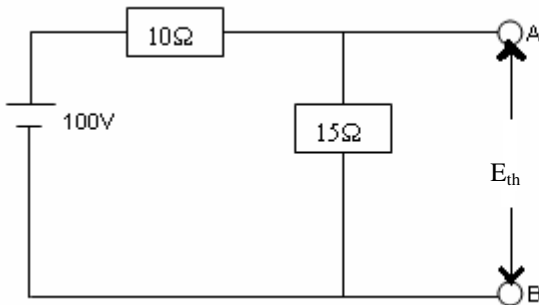


Fig. e

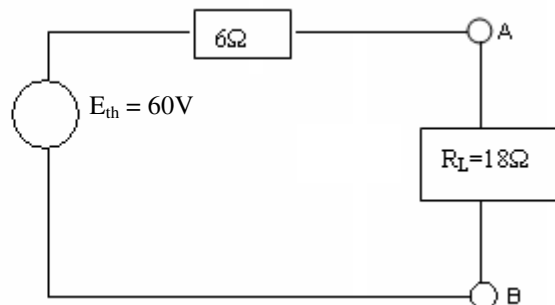


Fig. f

$$I = \frac{100}{10 + 15} = \frac{100}{25} = 4A$$

Voltage drop across 15Ω resistance = $15 \times 4 = 60$ Volts.

$E_{th} = 60$ Volts. The new circuit will be as shown in fig. f.

$$I = \frac{60}{6 + 18} = \frac{60}{24} = 2.5A \text{ and } V_{AB} = 2.5 \times 18 = 45 \text{ Volts.}$$

So, the current flowing through the load is 2.5A and the voltage across load is 45 Volts.

- Q.34** A series AC circuit connected to 230V, 50Hz mains consists of a non-inductive resistance of 100Ω and inductance of 100mH and a capacitance of $20\mu F$. Calculate – impedance, current, power factor and power. **(8)**

DE05
DE06

ELECTRICAL ENGINEERING
BASIC ELECTRONICS

Ans:

$$\text{Inductive reactance, } X_L = 2\pi f L = 2\pi \times 50 \times 100 \times 10^{-3} = 31.4\Omega$$

$$\text{Capacitive reactance, } X_C = 1 / 2\pi \times 50 \times 20 \times 10^{-6} = 159.24\Omega$$

$$\text{Impedance, } Z = \sqrt{R^2 + (X_L - X_C)^2} = \sqrt{(100)^2 + (31.4 - 159.24)^2} = 162.31\Omega$$

$$\text{Current, } I = V/Z = 230/162.31 = 1.42\text{A}$$

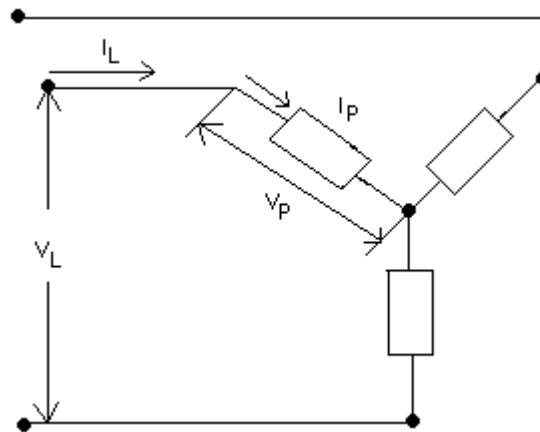
$$\text{Power factor } \cos\phi = R/Z = 100/162.31 = 0.616$$

$$\text{Power} = 230 \times 1.42 \times 0.616 = 201.2\text{W.}$$

- Q.35** A balanced star connected load is supplied from a symmetrical three- phase, 400V (line-to-line) supply. The current in each phase is 50A and lags behind the phase voltage by 30° . Find phase voltage, phase impedance and active and reactive power drawn by the load.

(8)

Ans:



$$V_L \text{ (line voltage)} = 400\text{V}; V_P \text{ (phase voltage)} = 400 / \sqrt{3} = 231\text{V}.$$

$$I_L \text{ (line current)} = I_P \text{ (phase current)} = 50 \angle -30^\circ$$

$$Z_P = 231 \angle 0^\circ / 50 \angle -30^\circ = 4.62 \angle 30^\circ \Omega = 4 + j2.31$$

$$P \text{ (active power)} = \sqrt{3} V_L I_L \cos \phi = \sqrt{3} \times 400 \times 50 \times \cos 30^\circ = 30\text{KW}.$$

$$Q \text{ (reactive power)} = \sqrt{3} V_L I_L \sin \phi = \sqrt{3} \times 400 \times 50 \times \sin 30^\circ = 17.32\text{KVAR}.$$

- Q.36** A series R-L-C circuit consists of a 100Ω resistor, an inductor of 0.318H and a capacitor of unknown value. When the circuit is energised by $230 \angle 0^\circ \text{V}$, 50Hz sinusoidal a.c. supply, the current is found to be $2.3 \angle 0^\circ \text{A}$. Find
- value of capacitor in microfarad.
 - voltage across the inductor.
 - total power consumed.

(14)

Ans:

$$\text{Supply voltage, } V = 230 \angle 0^\circ \text{ volts.}$$

$$\text{Current, } I = 2.3 \angle 0^\circ \text{ amperes.}$$

DE05
DE06ELECTRICAL ENGINEERING
BASIC ELECTRONICS

$$\begin{aligned} \text{Impedance} = Z &= V/I = 230/2.3 = 100 \Omega \\ \text{For R-L-C circuit} &= Z = \sqrt{100^2 + (X_L - X_C)^2} \\ 100 &= \sqrt{100^2 + (X_L - X_C)^2} \\ X_L &= X_C \\ 1/2\pi fC &= 2\pi fL \\ 1/2\pi \times 50 \times C &= 99.9 \\ \text{or, } C &= 1/2\pi \times 50 \times 99.9 = 31.85 \mu\text{F} \\ X_L &= 2\pi \times 50 \times 0.318 = 99.9 \Omega \\ \text{Voltage across the inductor} &= V_L = I \times X_L = 2.3 \times 99.9 = 229.77 \text{ V} \\ \text{Power consumed } P &= V I \cos \phi = 230 \times 2.3 \times 1 = 529 \text{ W} \\ \text{Or } P &= I^2 R = (2.3)^2 \times 100 = 529 \text{ W} \end{aligned}$$

- Q.37** The emf per turn of 3300 /395, 50Hz single- phase core type transformer is 7.5V, if the maximum flux density is 1 tesla, then find a suitable number of primary and secondary turns and the net cross- sectional area of the core.

(8)

Ans:Given V_1 (primary voltage) = 3300 volts V_2 (secondary voltage) = **395 volts.**Voltage per turn = 7.5 V, B_{\max} (max. flux density) = **1 tesla,** N_1 (number of primary turns) = 3300 / 7.5 = **440 turns** N_2 (number of primary turns) = 395 / 7.5 = 52.66 turns, $N_2 =$ **53 turns.**Therefore, primary number of turns may be taken = $N_1 = \frac{3300 \times 53}{395} = 443$ turns .

$$V_2 = E_2 = 4.44 \phi_{\max} f N_2 = 4.44 B_{\max} A f N_2$$

$$A = \frac{395}{4.44 \times 1 \times 50 \times 53} = 335.71 \text{ cm}^2 \text{ where } A = \text{area of cross section of the core, } f = \text{frequency,}$$

 $\phi_{\max} = \text{max. flux.}$

- Q.38** A 6- pole lap wound series motor has 60 slots; each slot consists of 12 conductors. If the armature current is 50 A, calculate the total torque in Nw -m. Flux per pole is 20×10^{-3} wb.

(4)

Ans:Where $Z = \text{No. of conductors} = 60 \times 12 = 720$; $P = \text{No. of poles} = 6$ (parallel paths) = 6: $\phi = \text{flux per pole} = 20 \text{ mWb}$, I_a (armature current) = 50 A.

$$\text{Torque} = \frac{1}{2\pi} \times \phi Z P \frac{I_a}{A} = \frac{1}{2 \times 3.14} \times 20 \times 10^{-3} \times 720 \times 6 \times \frac{50}{6} = 114.65 \text{ Nw - m .}$$

- Q.39** Two coils when connected in series have a resistance of 18 Ω and when connected in parallel have a resistance of 4 Ω . Find the resistance of each coil.

(8)

Ans: Let the resistances of the coils be R_1 and R_2 .Equivalent resistance when connected in series = $R_1 + R_2 = 18\Omega$. -----(1)Equivalent resistance when connected in parallel = $1/R_1 + 1/R_2 = 1/4\Omega$

$$\text{Or } 4 = \frac{R_1 R_2}{R_1 + R_2} \text{ -----(2)}$$

Multiplying (1) and (2)

$$R_1 R_2 = 72 \Omega \text{ -----(3)}$$

$$R_1 - R_2 = \sqrt{(R_1 + R_2)^2 - 4 R_1 R_2} = \sqrt{(18)^2 - 4 \times 72} = \pm 6 \Omega. \text{ -----(4)}$$

Adding (1) and (4),

$$2R_1 = 24 \text{ or } 12 \Omega, \text{ or}$$

$$R_1 = 12 \text{ or } 6 \Omega, \text{ and}$$

$$R_2 = 6\Omega \text{ or } 12\Omega.$$

- Q.40** a) A Wheatstone bridge consists of $AB = 4\Omega$, $BC = 3\Omega$, $CD = 6\Omega$ and $DA = 5\Omega$. A 2 volt cell is connected between B and D and a galvanometer of 10Ω between A and C. Find the current through the galvanometer. (8)

Ans:

The circuit is shown in fig. Applying Kirchoff's first law at junction B, A C, the current in various branches is marked. Applying Kirchoff's second law to various closed loops;

Considering loop BACB, we get,

$$-4I_1 - 10I_3 + 3I_2 = 0$$

$$4I_1 - 3I_2 + 10I_3 = 0 \text{ -----(1) Considering loop ADCA, we get}$$

$$-5(I_1 - I_3) + 6(I_2 + I_3) + 10I_3 = 0$$

$$\text{Or } -5I_1 + 5I_3 + 6I_2 + 6I_3 + 10I_3 = 0$$

$$\text{Or } 5I_1 - 6I_2 - 21I_3 = 0 \text{ -----(2)}$$

Considering loop BADEB, we get

$$-4I_1 - 5(I_1 - I_3) + 2 = 0$$

$$\text{Or } -4I_1 - 5I_1 + I_3 = -2$$

$$9I_1 - 5I_3 = 2 \text{ -----(3)}$$

Multiplying equation (1) by (2) and subtracting from equation (2) we get

$$5I_1 - 6I_2 - 21I_3 = 0$$

$$8I_1 - 6I_2 - 20I_3 = 0$$

$$\begin{array}{r} - \quad + \quad - \\ -3I_1 \quad -41I_3 = 0 \end{array}$$

$$I_1 = -\frac{41}{3} I_3$$

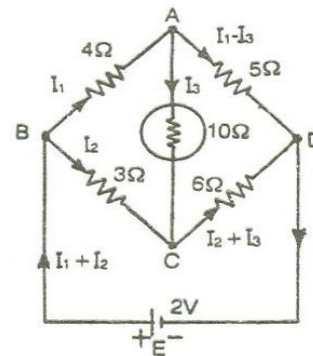
Substituting the value of I_1 in equation (3)

$$\text{We get, } 9\left(-\frac{41}{3} I_3\right) - 5I_3 = 2$$

$$-123I_3 - 5I_3 = 2$$

$$I_3 = -\frac{1}{64} \text{ A}$$

Current flowing through galvanometer is $1/64$ ampere from C to A.



- b) State the laws that are used to calculate the current in the above problem. (6)

Ans:

Kirchoff's laws were used in solving the above problem. Kirchoff's first law states that the algebraic sum of all currents meeting at a point is zero. $\Sigma I = 0$.

DE05
DE06ELECTRICAL ENGINEERING
BASIC ELECTRONICS

Kirchoff's second law states that, in a closed circuit, the algebraic sum of all the emf's plus the algebraic sum of all the voltage drops (i.e. product of current and resistances) is zero.

- Q.41** A 12 pole, 50 Hz induction motor is running at 450 rpm. Calculate the % slip of the motor on account of forward field. **(4)**

Ans:

Synchronous speed, $N_s = \frac{120 \times f}{P} = \frac{120 \times 50}{12} = 500 \text{ r.p.m.}$ Where f is the supply frequency.

Where P is the no. of poles.

$$\%S = \frac{N_s - N}{N_s} \times 100 = \frac{500 - 450}{500} \times 100 = 10\%$$

- Q.42** A 50 kVA, 5000/500V, 50Hz, 1-phase transformer has the high voltage winding with a resistance of 8 ohms and low voltage winding with a resistance of 0.06 ohms. The no load losses of the transformer amount to 1000W. Calculate the efficiency of the transformer, when delivering its full rated output at a power factor of 0.8? **(10)**

Ans: The no load loss in transformers is practically equal to the iron loss.

Hence Iron loss = 1000W

Full load loss = $I_2^2 R_{02}$

Now, $K = 5000/500 = 1/10$

$$\begin{aligned} R_{02} &= R_2 + k^2 R_1 \\ &= 0.06 + (1/10)^2 \times 8 \\ &= 0.14 \Omega \end{aligned}$$

Full load current $I_2 = 50,000/500 = 100 \text{ A}$

Full load Cu loss = $100^2 \times 0.14 = 1400 \text{ W}$

$$\begin{aligned} \text{Total Loss} &= 1000 + 1400 \\ &= 2400 \text{ W} \\ &= 2.4 \text{ kW} \end{aligned}$$

Full load output at 0.8pf = $50 \times 0.8 = 40 \text{ kW}$

Efficiency $\eta = 40/(40 + 2.4) = 0.9434 = 94.34\%$

- Q.43** A squirrel-cage induction motor has a full-load slip of 4%. Its starting current is 5 times its full load current. Calculate the starting torque in pu of the full load torque. Neglect the stator impedance and the magnetizing current. Also give a suitable remarks for the answer obtained. **(8)**

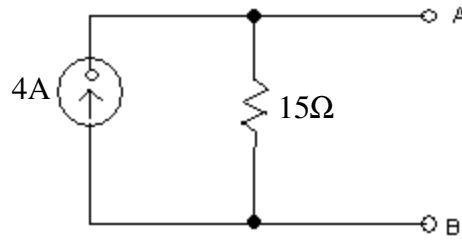
Ans: Example 12.14, p 467 of textbook

- Q.44** Convert 4A source with its parallel resistance of 15Ω into its equivalent voltage source **(3)**

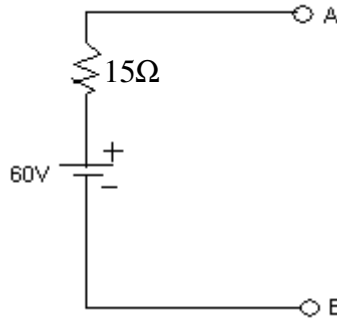
DE05
DE06

ELECTRICAL ENGINEERING
BASIC ELECTRONICS

Ans:



$$V_{oc} = I_S \cdot R_{IN} = 4 \times 15 = 60v$$



Q.45 Determine current flowing through 5Ω resistor in the circuit shown in Fig.1. Use transformation technique. (4)

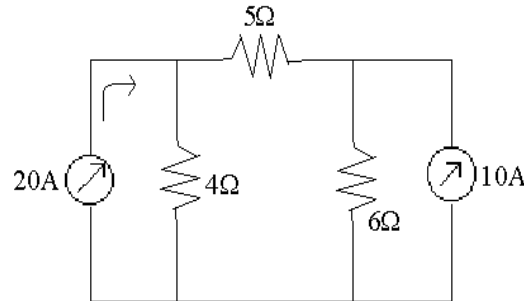


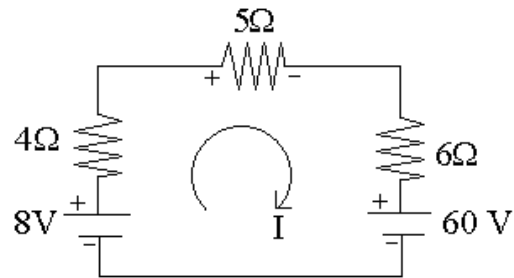
Fig.1

Ans:

Apply KVL, then $8 - I(4+5+6) - 60 = 0$

$$I = -\frac{52}{15} = -3.46A$$

(Negative direction shows current-flow in the opposite direction).



Q.46 Determine the range of unregulated supply for which the load current $0 \leq I_L \leq 200mA$ remains regulated.

DE05
DE06

ELECTRICAL ENGINEERING
BASIC ELECTRONICS

Assume $I_{Z\min} = 1\text{mA}$
 $I_{Z\max} = 300\text{mA}$
 and $V_Z = 5.6\text{V}$.

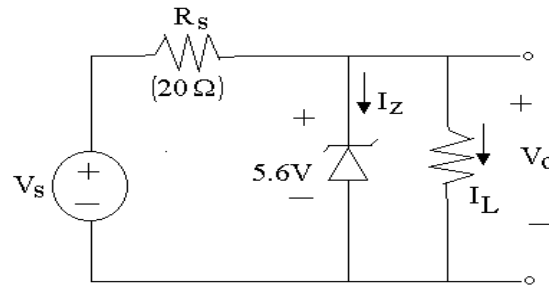


Fig.2

Ans:

$$V_{out} = V_Z = 5.6\text{v}$$

$$I_L = \frac{V_{out}}{R_L} \Rightarrow R_L = \frac{V_{out}}{I_L} \Rightarrow$$

When $I_L = 200\text{mA}$, Then $R_L = \frac{5.6}{200\text{m}}$
 $R_L = 28\Omega$.

$$I_{Z\min} = I_{S\min} - I_L$$

When $I_L = 0$, $I_{Z\min} = I_{S\min} = 1\text{mA}$.

When $I_L = 200\text{mA}$,

$$I_{Z\max} = I_{S\max} - I_L$$

$$I_{S\max} = I_{Z\max} + I_L = 300\text{m} + 200\text{m}$$

$$I_{S\max} = 500\text{mA}$$

Q.47 A 4:1 transformer supplies a bridge rectifier that is driving a load of 200 ohms. If the transformer input is 230 V/ 50 Hz supply, calculate the dc output voltage, PIV, and the output frequency. Assume the rectifier diodes to be ideal. (4)

Ans:

$$\frac{N_1}{N_2} = \frac{V_2}{V_1} = 4 \text{ and } V_1 = 230\text{V}$$

Therefore $V_2 = 57.5$

$$R_L = 200\Omega, V_{S\max} = 57.5$$

$$I_{\max} = \frac{V_{S\max}}{2R_F + R_L} = \frac{V_{S\max}}{R_L} = \frac{57.5}{200} = 0.287\text{A}$$

$$I_{dc} = \frac{2I_{\max}}{\pi} = 0.182\text{A}$$

$$V_{dc} = I_{dc} \cdot R_L = 0.182 \times 200 = 36.4\text{ Volts}$$

$$\text{PIV} = V_{S\max} = 57.5$$

$$I_{\text{rms}} = \frac{I_{\max}}{\sqrt{2}} = 0.202$$

Fundamental frequency of ripple = $2 \cdot f = 100\text{ Hz}$

DE05
DE06

ELECTRICAL ENGINEERING
BASIC ELECTRONICS

- Q.48** For a Zener shunt regulator, if $V_Z = 10\text{V}$, $R_S = 1\text{K}\Omega$, $R_L = 2\text{K}\Omega$ and the input voltage varies from 22 V to 40 V, find the minimum and maximum values of Zener current. (4)

Ans:

Input voltage

$$V_{\text{out}} = V_Z = 10\text{V},$$

$$R_S = 1\text{K}\Omega, R_L = 2\text{K}\Omega$$

$$V_{S\text{max}} = 40\text{V} \text{ and } V_{S\text{min}} = 22\text{V}$$

$$\text{Load current, } I_L = \frac{V_{\text{out}}}{R_L} = \frac{10\text{V}}{2\text{K}} = 5\text{mA}$$

$$\begin{aligned} I_{S\text{max}} &= \frac{V_{S\text{max}} - V_{\text{out}}}{R_S} \\ &= \frac{(40 - 10)\text{V}}{1\text{K}} \\ &= \frac{30\text{V}}{1\text{K}} \\ &= 30\text{mA} \end{aligned}$$

$$\begin{aligned} I_{Z\text{max}} &= I_{S\text{max}} - I_L \\ &= 30\text{mA} - 5\text{mA} \\ &= 25\text{mA} \end{aligned}$$

$$\begin{aligned} I_{S\text{min}} &= \frac{V_{S\text{min}} - V_{\text{out}}}{R_S} \\ &= \frac{22 - 10}{1\text{K}} \\ &= 12\text{mA} \end{aligned}$$

$$\begin{aligned} I_{Z\text{min}} &= I_{S\text{min}} - I_L \\ &= 12\text{mA} - 5\text{mA} \\ &= 7\text{mA} \end{aligned}$$

- Q.49** A transistor has $\beta = 150$. Calculate the approximate collector and base currents if the emitter current is 10 mA. (3)

Ans:

$$\beta = 150, I_E = 10\text{mA}.$$

DE05
DE06

ELECTRICAL ENGINEERING
BASIC ELECTRONICS

$$\alpha = \frac{\beta}{\beta + 1} = \frac{150}{151} = 0.99$$

$$\alpha = \frac{I_C}{I_E} = I_c = \alpha I_E = 0.99 \times 10 \text{mA}$$

$$I_C = 9.99 \text{mA}$$

$$I_B = \frac{I_C}{\beta} = \frac{9.9 \text{m}}{150} = 66 \mu\text{A}.$$

Q.50 The data sheet for an N-channel JFET provides the following:

$$I_{DSS} = 20 \text{mA}, V_P = -8 \text{V}, g_{mo} = 5000 \mu\text{v}$$

Determine the values of the drain current and transconductance for the device at

$$V_{GS} = -4 \text{volts}.$$

(3)

Ans:

$$I_{DSS} = 20 \text{mA}, V_P = -8 \text{V}, g_{mo} = 5000 \mu\text{mho}$$

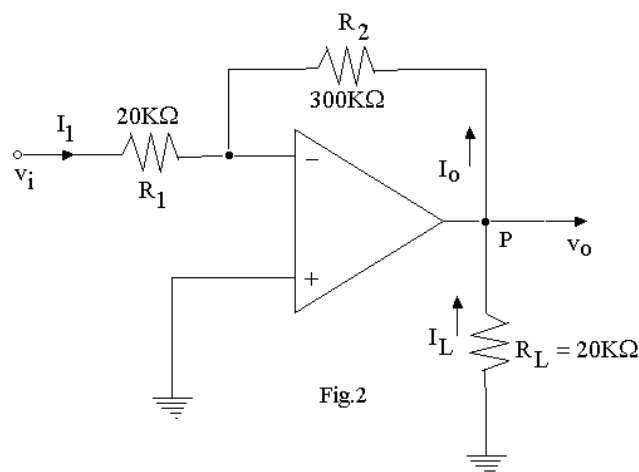
$$V_{GS} = -4 \text{volts}$$

$$I_D = I_{DSS} \left[1 - \frac{V_{GS}}{V_P} \right]^2 = 20 \times 10^{-3} \left[1 - \frac{-4}{-8} \right]^2 = 5 \text{mA}$$

$$g_m = g_{mo} \left[1 - \frac{V_{GS}}{V_P} \right] = 5000 \left[1 - \frac{-4}{-8} \right] = 2500 \mu\text{mho} \text{ or } 2.5 \text{mv}$$

Q.51 In the circuit shown in Fig.2, if $v_i = 1 \text{V}$, calculate I_1 , v_o , I_L and I_o .

(4)



DE05
DE06

ELECTRICAL ENGINEERING
BASIC ELECTRONICS

Ans:

$$I_1 = \frac{V_i}{R_1} = \frac{1}{20K} = 0.05mA$$

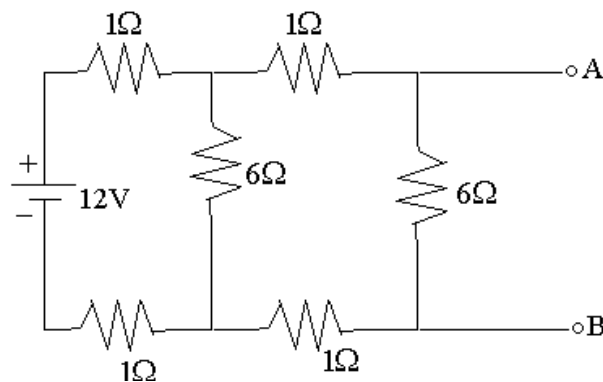
$$\frac{V_i}{R_1} = \frac{-V_o}{300K}$$

$$\frac{1}{20K} = \frac{-V_o}{300K} \Rightarrow V_o = \frac{-300K}{20K} = -15V$$

$$I_L = \frac{V_o}{R_L} = \frac{-15}{20K} = -0.75mA$$

$$I_L = \frac{V_o}{R_2} = \frac{-15}{300K} = -0.05mA$$

- Q.52** Determine Thevenin's equivalent circuit which may be used to represent the given network at the terminals A-B. (8)



Ans:

The open-circuit-voltage V_{OC} or V_T , which appears across terminals A and B when they are open, is given as

$$V_T = \frac{12}{1+1+6} \cdot 6$$

$$V_T = 9V$$

And the internal-resistance of the network R_{IN} (or R_T) when viewed from the output-terminals A and B is given as

$$R_T = \frac{2 \times 6}{2+6} = 1.5 \text{ ohms}$$

- Q.53** In an N-type semi conductor, the Fermi-level lies 0.3 eV below the conduction band at $27^\circ C$. If the temperature is increased to $55^\circ C$, find the new position of the Fermi-level. (8)

Ans:

At temperature $T = 300^0K = 273 + 27$,

$$E_C - E_F = 0.3eV$$

DE05
DE06

ELECTRICAL ENGINEERING
BASIC ELECTRONICS

W.K.T

$$E_C - E_F = KT \log_e n_c / N_D$$

$$\text{So, } 0.3 = 300K \log_e n_c / N_D;$$

$$K \log_e n_c / N_D = 0.3 / 300 = 0.001$$

At temperature $T' = 328 \text{ K} = (273 + 55)$,

Let the new position of the Fermi level be E_F ,

$$\text{so } E_C - E_F = KT \log_e n_c / N_D$$

$$E_C - E_F = 328 \times 0.001 = 0.328 \text{ V.}$$

- Q.54** In a transistor circuit load resistance is $5 \text{ k}\Omega$ and quiescent current is 1.2 mA . Determine the operating point when the battery voltage $V_{CC} = 12 \text{ V}$. How will the Q-point change when the load resistance is changed from $5 \text{ k}\Omega$ to $7.5 \text{ k}\Omega$? (8)

Ans:

Zero signal collector current $I_C = 1.2 \text{ mA}$, load resistance in collector circuit, $R_L = 5 \text{ k}\Omega$

collector supply voltage $V_{CC} = 12 \text{ V}$

Zero signal collector- emitter voltage

$$V_{CE} = V_{CC} - I_C R_C$$

$$= 12 - (1.2 \times 10^{-3} \times 5 \times 10^3) = 6 \text{ V}$$

Hence the operating point is $(6 \text{ V}, 1.2 \text{ mA})$

When load resistance is changed from $5 \text{ k}\Omega$ to $7.5 \text{ k}\Omega$

Zero signal collector- emitter voltage, $V_{CE} = V_{CC} - I_C R_C$

$$= 12 - (1.2 \times 10^{-3} \times 7.5 \times 10^3) = 3 \text{ V}$$

Here the operating point is $(3 \text{ V}, 1.2 \text{ mA})$

- Q.55** A half-wave rectifier having a diode of resistance $1,000 \Omega$ and a load of $1,000 \Omega$ rectifies an ac voltage of 310 V peak value. Calculate
- (i) peak, average and rms values of current.
 - (ii) dc power output.
 - (iii) ac power input.
 - (iv) efficiency. (8)

Ans:

$$V_{Smax} = 310 \text{ V}$$

$$V_{Srms} = \frac{310}{\sqrt{2}} = 220 \text{ V}$$

$$R_F = 1000\Omega, R_L = 1000\Omega,$$

$$I_{max} = \frac{V_{max}}{R_L + R_F} = \frac{310}{2K} = 165 \text{ mA}$$

$$I_{dc} = \frac{I_{max}}{\pi} = 52.51 \text{ mA}$$

$$I_{rms} = \frac{I_{max}}{2} = \frac{165}{2} = 82.5 \text{ mA}$$

$$PIV = V_{Smax} = 310 \text{ V}$$

$$V_{dc} = I_{dc} R_L = 52.51 \text{ m} \times 1K = 52.51 \text{ V}$$

$$\text{DC output power, } P_{dc} = I_{dc}^2 R_L = (52.51 \text{ m})^2 \times 1K = 2.757 \text{ W}$$

$$\text{AC input power, } P_{ac} = \frac{I_{max}^2}{4} (R_L + R_F) = \frac{(165 \text{ m})^2}{4} \times (2K) = 13.61 \text{ W}$$

$$\eta = \frac{P_{dc}}{P_{ac}} \times 100 = \frac{2.757}{13.61} \times 100 = 20.257 \%$$

Q.56 Implement the following equation using two operational amplifiers $V_0 = -5V_1 + 2V_2 - 10V_3$. Use minimum value of resistance as $10k\Omega$. (8)

Ans:

$$V_{out1} = - \left[\frac{R_f}{R_1} V_1 - \frac{R_f}{R_2} V_2 \right]$$

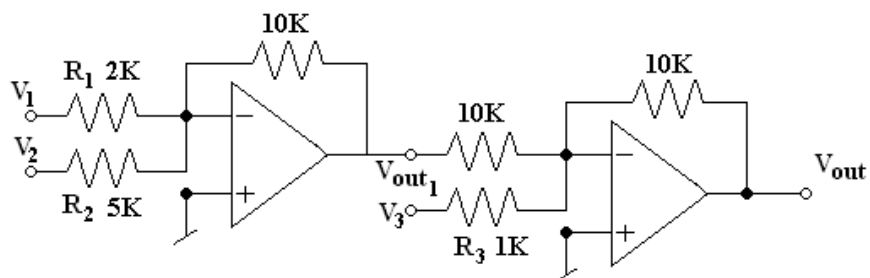
$$V_{out} = - \left[\frac{R_f}{R_3} V_3 - \frac{R_f}{R_4} V_{out1} \right]$$

$$\frac{R_f}{R_1} = \frac{10k}{2K} = 5$$

$$\frac{R_f}{R_2} = \frac{10k}{5K} = 2$$

$$\frac{R_f}{R_3} = \frac{10k}{1K} = 10$$

$$\frac{R_f}{R_4} = \frac{10k}{10K} = 1$$

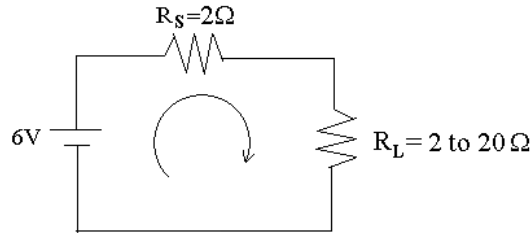


DE05
DE06

ELECTRICAL ENGINEERING
BASIC ELECTRONICS

- Q.57** A dc source of strength 6 volts is driving a load whose resistance varies from two to twenty ohms. Compute the variation in terminal voltage for the source as a percentage. Take the source resistance as two ohms. (2)

Ans:



$$R_{L\min} = \frac{V_{FL}}{I_{FL}}; \text{ where } R_L = 2$$

At fullload condition: when $R_L = 2$

$$I_{FL} = \frac{V_{FL}}{R_{L\min}} = I_{FL} = \frac{6}{4} = 1.5$$

$$\therefore V_{FL} = I_{FL} \times R_{L\min} = 2 \times 1.5 = 3$$

Similarly, when $R_L = 20\Omega$,

No load conditions

$$I_{NL} = \frac{V_{NL}}{R_{L\max}}$$

$$\text{Then } I_{NL} = \frac{6}{2 + 20} = 0.272$$

$$\therefore V_{NL} = 0.272 \times 20 = 5.44$$

$$\%LR = \frac{V_{NL} - V_{FL}}{V_{FL}} \times 100 = \frac{5.44 - 3}{3} \times 100 = 81.33\%$$

- Q.58** A centre-tap full-wave rectifier is supplying to a load of one kilo-ohm. If the voltage across half the secondary winding of the input transformer is $220 \sin \omega t$, calculate the following:

- (i) the peak value of current (ii) the average value of the current
(iii) the r.m.s. value of current (iv) the ripple factor
(v) the efficiency of rectification

For the diodes used assume each having their forward resistance is 10 ohms. (10)

DE05
DE06

ELECTRICAL ENGINEERING
BASIC ELECTRONICS

Ans:

$$R_L = 1k\Omega, V_{S_{\max}} = 220., R_F = 10\Omega$$

At fullload conditions

$$(i) I_{\max} = \frac{V_{S_{\max}}}{R_L + R_F} = \frac{220}{1K + 10} = 0.2178A$$

$$(ii) I_{dc} = \frac{2I_{\max}}{\pi} = \frac{2 \times 0.2178}{\pi} = 0.1386A$$

$$(iii) I_{rms} = \frac{I_{\max}}{\sqrt{2}} = \frac{0.2178}{\sqrt{2}} = 0.154A$$

$$(iv) \text{Ripple factor } \gamma = \sqrt{\left(\frac{I_{rms}}{I_{dc}}\right)^2 - 1} = \sqrt{\left(\frac{0.154}{0.1386}\right)^2 - 1} = 0.234$$

$$(v) \eta = \frac{0.812}{1 + R_F / R_L} = \frac{0.812}{1 + 10/1000} = 80.39\%$$

- Q.59** A half-wave rectifier has a peak output voltage of 12.2V at 50 hertz and feeds a resistive load of 100 ohms. Determine the value of the shunt capacitor to give one percent ripple factor and the dc voltage output. **(6)**

Ans:

$$R_L = 100\Omega, f = 50\text{Hz}, rf = 1\% = 0.01$$

$$\text{ripple factor}(rf) = \frac{1}{2\sqrt{3}fcR_L}$$

$$C = \frac{1}{2\sqrt{3} \times 50 \times 100 \times 0.01} = 5.77\text{mf}$$

$$V_{L_{\max}} = 12.2\text{v}$$

$$I_{dc} \left[R_L + \frac{I_{dc}}{2fc} \right] = V_{L_{\max}}$$

$$I_{dc} = \frac{V_{L_{\max}}}{R_L + 1/2fc} = \frac{12.2}{100 + 1/2 \times 50 \times 5.77 \times 10^{-3}} = 0.1199A$$

$$V_{dc} = V_{L_{\max}} - \frac{I_{dc}}{2fc} = 12.2 - \frac{0.1199}{2 \times 50 \times 5.77 \times 10^{-3}} = 11.99\text{v.}$$

- Q.60** A transistor has an alpha dc of 0.98 and a collector leakage current of one microampere. If the emitter current is one milli-ampere, find the magnitude of the collector and the base currents. **(4)**

Ans :

$$\alpha_{dc} = 0.98, I_{CBO} = 1\mu A, I_E = 1mA$$

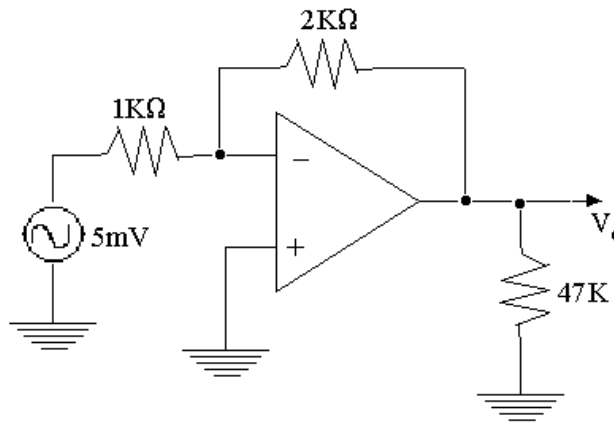
$$I_C = \alpha_{dc} I_E + I_{CBO} = 0.98 \times 1m + 1\mu = 0.981mA$$

$$I_E = I_C + I_B$$

$$\therefore I_B = I_E - I_C = 1m - 0.981m = 0.019mA$$

Q.61 For the circuit shown calculate the following:

- (i) the closed loop voltage gain.
- (ii) the feedback fraction and
- (viii) the closed-loop input impedance seen by the a.c. source. (3)



Ans :

$$R_1 = 1 \text{ k}\Omega, R_f = 2 \text{ k}\Omega, V_{in} = 0.1 \text{ V}$$

$$A_f = \frac{-R_f}{R_1} = \frac{-2k}{1k} = -2$$

$$R_{i_n} = R_1 = 1k\Omega$$

$$V_{out} = A_f \cdot V_{in} = -2 \times 5m = -10mv$$

$$I_{i_n} = \frac{V_{in}}{R_1} = \frac{5m}{1k} = 5A$$

Q.62 Determine the current flowing through the load resistor (R_L) when $R_L = 6K\Omega$ for the network shown below in Fig.1 by using Thevenin's theorem. (5)

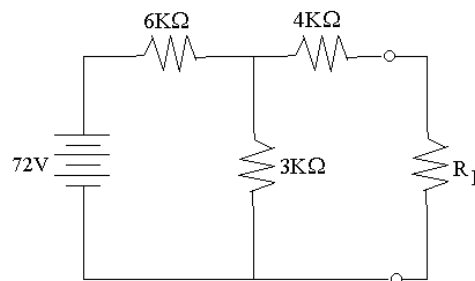


Fig.1

DE05
DE06

ELECTRICAL ENGINEERING
BASIC ELECTRONICS

Ans :

Equivalent resistance of the network with reference to load terminals A & B (with voltage source short-circuited)

$$R_T = 4k + 6k \text{ parallel with } 3K$$

$$R_T = 4k + \frac{18k}{9k} = 6k$$

When terminals A & B are open the current flowing through the mesh is found by voltage source and $6k\Omega$ & $3k\Omega$ resistors.

$$I = \frac{72}{9k} = 8mA$$

$$\text{open-circuit voltage } V_{AB} = I \times 3k\Omega = 8m \times 3k = 24v$$

The current through $6k\Omega = R_L$ is I_L

$$I_L = \frac{V_{AB}}{R_T + R} = \frac{24}{6k + 6k} = 2mA$$

$$\therefore I_L = 2mA$$

- Q.63** Calculate the Intrinsic conductivity of silicon at room temperature if $n = 1.41 \times 10^{16} m^{-3}$, $\mu_e = 0.145 m^2/Vs$, $\mu_n = 0.05 m^2/Vs$ and $e = 1.6 \times 10^{-19} C$. What are the individual contributions made by electrons and holes? **(4)**

Ans :

Conductivity of silicon (intrinsic),

$$\sigma_i = n_i e (\mu_e + \mu_n)$$

$$\sigma_i = 1.41 \times 10^{16} \times 1.6 \times 10^{-19} (0.145 + 0.05)$$

$$\sigma_i = 4.39 \times 10^{-4} s/m$$

- Q.64** Find the static and the dynamic resistance of a p-n junction Germanium diode, if the temperature is $27^\circ C$ and $I_S = 1\mu A$ for an applied forward bias of $0.2V$. **(4)**

Ans :

$$R = \frac{V}{I} = \frac{0.2}{1 \times 10^{-6}} = 200k\Omega$$

$$\text{Static resistance } ac \text{ resistance (dynamic)} = \frac{\eta V_T}{I_S e^{V/\eta V_T}} = \frac{0.026}{1 \times 10^{-6} e^{0.2/0.026}} \text{ for } \eta = 1$$

$$= 11.86\Omega$$

- Q.65** A half-wave rectifier using silicon diode has a secondary e.m.f of $14.14V$ (r.m.s.) with a resistance of 0.2Ω . The diode has a forward resistance of 0.05Ω and a threshold voltage of $0.7V$. If the load resistance is 10Ω . Determine

- (i) d.c. load current. (ii) d.c. load voltage.
(iii) Voltage regulation. (iv) Efficiency. **(5)**

DE05
DE06

ELECTRICAL ENGINEERING
BASIC ELECTRONICS

Ans :

$$V_{S_{rms}} = 14.14V,$$

$$\text{Peak value of supply voltage} = V_{S_{max}} = 14.14 \sqrt{2} V$$

$$R_F = 0.05 \Omega, R_L = 10 \Omega$$

$$I_{max} = \frac{V_{S_{max}}}{R_L + R_F} = \frac{14.14 \sqrt{2}}{10 + 0.05} = 1.989 \approx 2A.$$

$$I_{dc} = \frac{I_{max}}{\pi} = \frac{2}{\pi} = 0.636A$$

$$I_{rms} = \frac{I_{max}}{2} = \frac{2}{2} = 1A$$

$$PIV = V_{S_{max}} = 2V$$

$$V_{dc} = I_{dc} R_L = 0.636 \times 10 = 6.36V$$

$$\text{DC output power} = P_{dc} = I_{dc}^2 R_L = (0.636)^2 \times 10 = 4.04W$$

$$\text{AC input power} = P_{ac} = \frac{I_{max}^2}{4} (R_L + R_F) = \frac{2^2}{4} \times (0.05 + 10) = 10.05W$$

$$\eta = \frac{P_{dc}}{P_{ac}} \times 100 = \frac{4.04}{10.05} \times 100 = 40.19\%$$

- Q.66** The current gain α of an n-p-n transistor is 0.98. It is connected in the CB mode and gives a reverse saturation current $I_{CO} = 12\mu A$. Find the Base and the collector currents for an Emitter current of 2mA. (4)

Ans :

$$I_E = 2mA, \alpha = 0.98, I_{CO} = 12\mu A$$

$$I_C = \alpha I_E + I_{CO}$$

$$I_C = 0.98 \times 2 \times 10^{-3} + 12 \times 10^{-6} = 1.972mA$$

$$I_B = I_E - I_C = 2 - 1.972 = 28\mu A$$

- Q.67** A half-wave rectifier having a diode of resistance $1,000\Omega$ and a load of $1,000\Omega$ rectifies an ac voltage of 310 V peak value. Calculate
 (i) peak, average and rms values of current.
 (ii) dc power output.
 (iii) ac power input.
 (iv) efficiency. (8)

Ans:

$$V_{S_{max}} = 310V$$

DE05
DE06

ELECTRICAL ENGINEERING
BASIC ELECTRONICS

$$V_{S_{rms}} = \frac{310}{\sqrt{2}} = 220V$$

$$R_F = 1000\Omega, R_L = 1000\Omega,$$

$$I_{max} = \frac{V_{max}}{R_L + R_F} = \frac{310}{2K} = 165mA$$

$$I_{dc} = \frac{I_{max}}{\pi} = 52.51mA$$

$$I_{rms} = \frac{I_{max}}{2} = \frac{165}{2} = 82.5mA$$

$$PIV = V_{S_{max}} = 310V$$

$$V_{dc} = I_{dc} R_L = 52.51m \times 1K = 52.51V$$

$$\text{DC output power, } P_{dc} = I_{dc}^2 R_L = (52.51m)^2 \times 1K = 2.757W$$

$$\text{AC input power, } P_{ac} = \frac{I_{max}^2}{4} (R_L + R_F) = \frac{(165m)^2}{4} \times (2K) = 13.61W$$

$$\eta = \frac{P_{dc}}{P_{ac}} \times 100 = \frac{2.757}{13.61} \times 100 = 20.257\%$$

Q.68 In the circuit shown below in Fig.2, calculate

- (i) V_o (ii) A_{CL} (iii) The Load Current I_L
(iv) The output current I_o indicating proper direction of flow. (6)

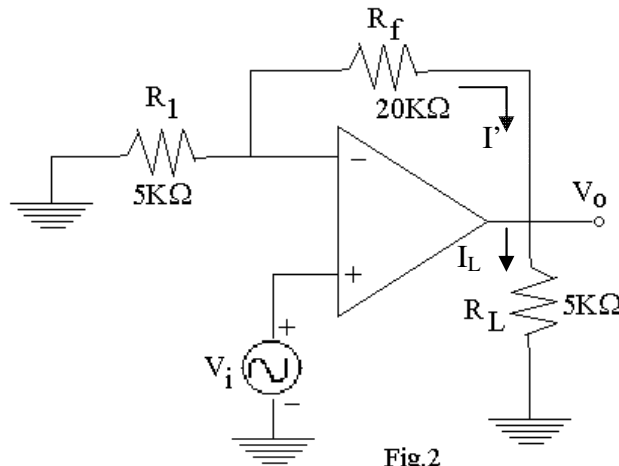


Fig.2

Ans :

$$V_{out} = \left(1 + \frac{R_f}{R_1}\right) V_i$$

$$A_{CL} = V_{out} / V_{in} = \left(1 + \frac{R_f}{R_1}\right) = 1 + 20k/5k = 5$$

DE05
DE06ELECTRICAL ENGINEERING
BASIC ELECTRONICS

$$\text{At node A, } I' = I_L = \frac{0 - V_o}{R_f} = \frac{-V_o}{R_f} = I_L$$

$$\text{Assume } V_{in} = 1 \text{ then, } V_{out} = \left(1 + \frac{R_f}{R_1}\right) = 1 + 20k/5k = 5v$$

$$\text{Then } I_L = \frac{-V_o}{R_f} = \frac{-5}{20k} = 0.25mA \text{ and}$$

$$I_o = I_L$$

Q.69 A bridge rectifier is driven by a transformer of turns ratio $n_1 : n_2 = 12 : 1$. If the primary of the transformer is connected to the 220V, 50Hz, 1 ϕ power mains, evaluate the following for the rectifier:

- (i) the dc load voltage (ii) the PIV of each diode
(iii) the dc load current

Assume the diodes to be ideal.

(7)

Ans :

$$V_{S_{max}} = 220V$$

$$\frac{N_2}{N_1} = \frac{1}{12} = \frac{V_2}{V_1} \Rightarrow V_2 = \frac{V_1}{12} = \frac{V_{S_{max}}}{12} = \frac{220}{12} = 18.33V$$

$$PIV = V_{S_{max}} = 220V$$

$$I_{max} = \frac{V_{S_{max}}}{2R_F + R_L} \text{ and } I_{dc} = \frac{2I_{max}}{\pi}$$

Q.70 Define $V_{S_{max}}$ the term percentage regulation of a power supply. An unregulated voltage source of resistance 600 ohms is connected across a zener diode to form a shunt regulator. Zener diode used has the following parameters:

Breakdown voltage = 5.1 volts,

Zener resistance (r_z) = 10 ohms;

Minimum and maximum values of current through zener = 1 mA and 15 mA respectively. Determine the minimum and maximum values of the input voltage which can be regulated by the zener. (12)

Ans :

The percentage of source regulation is given as

$$\% SR = \frac{V_{HL} - V_{LL}}{\text{No min al Load Voltage}} \times 100$$

Where V_{HL} \rightarrow output voltage with high input ac line voltage.

Where V_{LL} \rightarrow output voltage with low input ac line voltage.

$$V_Z = V_{OUT} = 5.1 \text{ Volts.}$$

$$I_{S \max} = \frac{V_{S \max} - V_{out}}{R_S} \Rightarrow I_{S \max} R_S = V_{S \max} - V_{out}$$

$$V_{S \max} = V_{out} + I_{S \max} R_S = 5.1 + 15m \times 600 = 14.1V$$

$$I_{S \min} R_S = V_{S \min} - V_{out}$$

$$V_{S \min} = V_{out} + I_{S \min} R_S$$

$$V_{S \min} = 5.1 + 1m \times 600 = 5.7 \text{ volts}$$

- Q.71** When the emitter current of a transistor is changed by 1mA, its collector changes by 0.995 mA. Evaluate the common-base short circuit current gain and the common-emitter short circuit current gain for the transistor. **(4)**

Ans :

$$I_E = 1\text{mA} \text{ and } I_C = 0.995\text{mA}$$

$$\alpha = \frac{I_C}{I_E} = \frac{0.995}{1} = 0.995$$

$$\beta = \frac{\alpha}{1 - \alpha} = \frac{0.995}{1 - 0.995} = 199$$

- Q.72** What are photoelectrons? Light of wavelength $4000 \times 10^{-10} \text{m}$, falls on a metal having work function of 1.5eV. Determine
(i) the energy of incident photon and
(ii) the kinetic energy of photoelectrons.
Take Planck's constant as $6.62 \times 10^{-34} \text{Js}$. **(8)**

Ans :

When the surface of certain alkaline material such as sodium, potassium, cesium or rubidium is illuminated by a beam of light or ultra violet radiations, the electrons are emitted. The phenomenon is called photo electrons.

$$\lambda = 4000 \times 10^{-10} \text{m}; h = 6.62 \times 10^{-32} \text{J/s}$$

$$\text{Energy of incident photon} = \frac{12.4 \times 10^{-7}}{4000 \times 10^{-10}} = 3.1 \text{ eV}$$

$$\phi = 1.5 \text{ eV}$$

$$\therefore \lambda_o = C / f_o = Ch / e\Phi$$

$$= \frac{3 \times 10^8 \times 6.62 \times 10^{-32}}{1.602 \times 10^{-19} \times 1.5}$$

$$\lambda_o = 0.185 \times 10^{-3}$$

- Q.73** In a centre-tap full-wave rectifier, the load resistance $R_L = 1\text{K}\Omega$. Each diode has a forward-bias dynamic resistance r_d of 10Ω . The voltage across half the secondary winding is $220 \sin 314t$. Find
(i) the Peak value of current
(ii) the dc or average value of current

- (iii) the rms value of current
- (iv) the ripple factor and
- (v) the rectification efficiency (7)

Ans :

$V_{Smax}=220$, Forward Resistance $R_F=10\Omega$, $R_L=1K\Omega$

- i) Peak of current, $I_{max} = \frac{V_{Smax}}{R_L + R_F} = \frac{220}{1k + 10} = 0.2A$
- ii) Average current, $I_{dc} = \frac{2I_{max}}{\pi} = \frac{2 \times 0.2}{\pi} = 0.127A$
- iii) RMS value of current, $I_{rms} = \frac{I_{max}}{\sqrt{2}} = \frac{0.2}{\sqrt{2}} = 0.141A$
- iv) The ripple factor, $\gamma = \sqrt{\left(\frac{I_{rms}}{I_{dc}}\right)^2} - 1 = \sqrt{\left(\frac{0.141}{0.127}\right)^2} - 1 = 0.3320$
- v) Efficiency, $\eta = \frac{0.812}{1 + \frac{R_F}{R_L}} = \frac{0.812}{1 + \frac{10}{1000}} = 80.39\%$

Q.74 For an N-channel JFET, $I_{DSS} = 8.7mA$, $V_P = -3V$ and $V_{GS} = -1V$, then find the value of drain current (I_D). (4)

Ans :

$$I_D = I_{DSS} \left[1 - \frac{V_{GS}}{V_P} \right]^2$$

$$I_D = 8.7 \times 10^3 \left[1 - \frac{-1}{-3} \right]^2 = 3.86mA$$

Q.75 An operational amplifier shown in Fig.3 has feedback resistor $R_f = 12 K\Omega$ and the resistances in the input sides are $R_{S1}=12K\Omega$, $R_{S2}=2K\Omega$ and $R_{S3}=3K\Omega$. The corresponding inputs are $V_{i1} = +9V$, $V_{i2} = -3V$ and $V_{i3} = -1V$. Non-inverting terminal is grounded. Calculate the output voltage. (4)

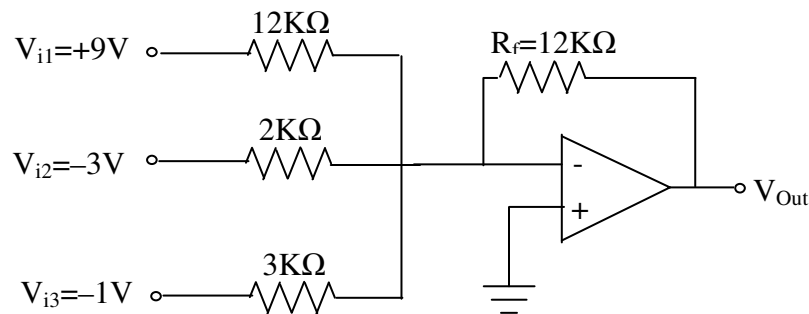


Fig 3

DE05
DE06

ELECTRICAL ENGINEERING
BASIC ELECTRONICS

Ans :

$$V_{OUT} = - \left[\frac{R_f}{R_1} V_1 + \frac{R_f}{R_2} V_2 + \frac{R_f}{R_3} V_3 \right]$$

$$- \left[\frac{12k}{12k} \times 9 + \frac{12k}{2k} \times -3 + \frac{12k}{3k} \times -1 \right]$$

$$V_{OUT} = -[9 - 18 - 4] = 13V$$

Q.76 A bridge rectifier is driven by a transformer of turns ratio $n_1:n_2=12:1$. If the primary of the transformer is connected to the 220V, 50Hz, 10 power mains, evaluate the following for the rectifier.

- (i) The dc-load voltage
 - (ii) The PIV of each diode
 - (iii) The dc-load current
- Assume the diodes to be ideal

Ans:

$$V_{S_{max}} = 220V,$$

$$\frac{N_2}{N_1} = \frac{1}{12} = \frac{V_2}{V_1} \Rightarrow$$

$$V_2 = \frac{V_1}{12} = \frac{V_{S_{max}}}{12} = \frac{220}{12} = 18.33V$$

$$PIV = V_{S_{max}} = 220V$$

$$I_{max} = \frac{V_{S_{max}}}{2R_F + R_L} \text{ and}$$

$$I_{dc} = \frac{2I_{max}}{\pi}$$