

111403-PRODUCTION TECHNOLOGY

Aim:

The automobile components such as piston, connecting rod, crankshaft, engine block, front axle, frame, body etc., are manufactured by various types of production processes involving casting, welding, machining, metal forming, power metallurgy etc. Hence B.E. Automobile Engineering students must study this course Production Technology

Objectives:

To study and understand manufacturing of various types of production processes involving casting, welding, machining, metal forming, power metallurgy etc

To study and understand manufacturing of automobile components such as piston, connecting rod, crankshaft, engine block, front axle, frame, body etc

TEXT BOOKS

1. Hajra Choudhury, "Elements of Workshop Technology", Vol. I and II, Media Promoters and Publishers Pvt., Ltd., Mumbai, 2005.
2. Nagendra Parashar B.S. and Mittal R.K., "Elements of Manufacturing Processes", Prentice-Hall of India Private Limited, 2007.

REFERENCES

1. Serope Kalpajian, Steven R.Schmid, "Manufacturing Processes for Engineering Materials", 4/e, Pearson Education, Inc. 2007.
2. R.K.Jain and S.C. Gupta, "Production Technology", Khanna Publishers. 16th Edition, 2001.
3. "H.M.T. Production Technology – Handbook", Tata McGraw-Hill, 2000.
4. Roy. A. Linberg, "Process and Materials of Manufacture", PHI, 2000.
5. M. Adithan and A.B. Gupta, "Manufacturing Technology", New Age, 2006.

UNIT I

CASTING:

Casting is a manufacturing process by which a liquid material is usually poured into a mold, which contains a hollow cavity of the desired shape, and then allowed to solidify. The solidified part is also known as a casting, which is ejected or broken out of the mold to complete the process. Casting materials are usually metals or various *cold setting* materials that cure after mixing two or more components together; examples are epoxy, concrete, plaster and clay. Casting is most often used for making complex shapes that would be otherwise difficult or uneconomical to make by other methods

CASTING AND PHASE DIAGRAMS

OBJECTIVE

In this experiment, you will become familiar with sand casting, a common industrial fabrication process. Upon completion of the module you should be able to use equilibrium phase diagrams to interpret solidification processes.

Casting, one of the oldest manufacturing processes, consists of pouring a molten metal into a mold cavity, where it solidifies in the shape of the cavity. Casting can produce complex shapes (including internal cavities) and large parts with small material wastage. A disadvantage of casting is that during solidification, coring occurs, and as a result, solute elements are concentrated at the grain boundaries. If these elements form brittle particles, the cast alloy will have a low ductility. A post-casting normalizing heat treatment may reduce the solute segregation.

In this lab, you will make a sand mold and assist in the melting and casting processes. You will get exposure to the process parameters in casting: fluid flow, heat transfer, metal solidification rates, and design of the metal feeding system. Thermocouples embedded in thick and thin sections of each mold will be used to generate direct cooling curves. Inflection temperatures will be compared to the equilibrium liquidus and solidus of the alloy system.

PROCEDURE FOR MAKING THE CASTING

1. Make a mold from the oil bonded sand. Place one thermocouple in the thin section and one in the thick section of the mold.
2. Begin melting the metal in the induction furnace as mold nears completion. Be sure to wear safety gear around the furnace. Set-up the PC data acquisition system and the Notebook program.

3. Place the mold in the sandbox. Connect the thermocouples to the leads from the PC data acquisition system.
4. Skim the oxide from the surface of the melt. Remove furnace from the crucible, start the data collection program, and pour the metal into the sand mold.
5. **CAUTION!** Students not assisting in the pouring operation should stand back as splattering of the molten metal may occur. Remember, the aluminum is above 600°C. Also, the oil in the molding sand will begin to burn, giving off noxious fumes.
6. After solidification and cooling (>10 min.) remove the casting from the mold and inspect it.

METAL CASTING PROCESSES

Casting is the process of forming objects by pouring liquid or viscous material into a prepared mold or form.

Examples: Carburetors, frying pans, engine blocks, crankshafts, railroad-car wheels, plumbing fixture, power tools, gun barrels, machine tool is bases etc.

Properly designed and properly produced castings do not have directional properties. Casting can produce complex shapes. Cast iron has also very good dampening characteristics.

Importance of casting

Complex shapes can be produced.
Minimal directional properties are obtained
Hollow sections can be produced
Very large part can be produced.
Metals that are very difficult to machine can be used to produce an object.

Metals that can be casted

Iron, steel, Al, brass, bronze, Magnesium and certain Zinc alloys.

Various Casting processes have been developed; each has its own characteristics and applications to meets specific engineering and service requirements.

Sand casting,
Die Casting,
Centrifugal Casting,
Shell-Mold Casting,

Investment Casting,
Permanent-Mold Casting etc.

There are two major categories of casting:

Expendable mold casting
Permanent mold casting

Expendable molds: Made of sand, plaster, ceramics and similar materials which are generally mixed with various binders or bonding agents, the molds are broken up to remove the casting.

Made of sand, plaster, ceramics and similar materials which are generally mixed with various binders or bonding agents, the molds are broken up to remove the casting.

Permanent molds: Used repeatedly and are designed in such a way that casting can be easily removed and the mold used for the next casting.

Composite Molds: Made of two or more different materials (such as sand, graphite, and metal) combining the advantages of each material. Used to improve mold strength, cooling rates and overall economics of the process.

Sand Casting

A traditional method (has been used for millennia)

Steps consists of:

Placing a pattern in sand to make an imprint,

Incorporating a gating system,

Filling the resulting cavity with molten metal

Allowing the metal to cool until it solidifies

Breaking the sand mold and removing the casting.

Sands

Most sand casting operations use silica sand (SiO_2).

Inexpensive and suitable as mold material because of its resistance to high temperatures

Two general types of sands: **Naturally bonded** (bank sands) and synthetic (lake sands).

Synthetic sand is preferred (because its composition can be controlled more accurately).

Important factors in selecting sand for molds:

Sand having fine, round grains can be closely packed and forms a smooth mold surface. Good permeability of molds and cores allows gases and

steam evolved escape easily. The mold should have good collapsibility to avoid defects in the casting such as (hot tearing and cracking).

So, selection of sand involves certain tradeoffs with respect to properties

Sand is usually conditional before use.

Mulling machines are used to uniformly mull (mix thoroughly) sand with **additives**. **Clay** (bentonite) is used as a cohesive agent to bond sand particles (giving the sand strength). **Zircon** ($ZrSiO_4$), **Olivine** (Mg_2SiO_4) and **Iron silicate** (Fe_2SiO_4) sands are often used in steel foundries for their low thermal expansion. Chromite ($Fe_2Cr_2O_4$) is used for its high heat transfer properly.

Molds

A mold is a container that has the cavity or cavities of the shape to be casted.

Flask: A flask is a wood or metal frame in which a mold is made. A flask is made of two principal parts, the cope (top section) and the drag (bottom section). To increase the depth of the cope and/or the drag, intermediate sections, known as cheeks, are used

Pouring basin or pouring cap: into which the molten metal is poured.

Sprue: through which the molten metal flows downward.

Runner system: channels to carry the molten metal from the sprue to the mold cavity. Gates are inlets into the mold cavity.

Risers: supply additional metal to the casting as it shrinks during solidification.

Cores: inserts made from sand. They are placed in the mold to form hollow regions or otherwise define the interior surface of the casting. Cores are also used on the outside of the casting to form features such as telling on the side of a casting or deep external pockets.

Vents: carry off gases produced when the molten metal comes in contact with the sand in the molds and core. Also exhaust air from the mold cavity comes out through vents as the molten metal flows into the mold.

Desirable characteristics of Molds

The mold must be strong enough to hold the weight of the metal.

The mold must resist the erosive action of the rapidly flowing molten metal during pouring.

The mold must generate a minimum amount of gas when filled with molten metal.

The mold must provide enough venting so that any gases formed can pass through the body of the mold itself, rather than penetrate the metal.

The mold must be refractory enough to withstand the high temperature of the molten metal and strip away cleanly from the casting after cooling.

The mold must permit the casting to contract after solidification.

Classification of molds

Depending on the materials used, Molds are classified as follows:

Green-sand molds: Molds made with damp molding sand.

Skin-dried molds: Two methods.

First-The sand around the pattern to a depth of about ½ inch is mixed with a binder so that when it is dried it will leave a hard surface on the mold. The remainder of the mold is made up of ordinary green sand.

Second-The entire mold is made with green sand and then coat its surface with a spray or wash, which hardens when it is applied.

Spray used are: linseed oil, molasses water, gelatinized starch etc.

In both of them mold is dried either by air or by a torch to harden the surface and drive cut excess moisture.

Dry sand molds: Fairly coarse molding sand mixed with a binding material is used. Flasks are of metal, since molds must be oven baked before being used. It is free from gas troubles due to moisture. Skin-dried and dry-sand molds are widely used in steel foundries.

Loam molds: It is first built up with bricks or large iron parts; these parts are then plastered over with a thick Loam mortar, the shape of the cavity being obtained with sweeps or skeleton patterns. The mold is then allowed to dry thoroughly. It needs long time to make and is not used extensively.

Furan molds: Dry, sharp sand is thoroughly mullied with phosphoric acid which acts as an accelerator==> furan resin is added and mulling is continued==>the sand materials begins to air harden almost immediately.

CO2 molds: Clean sands is mixed with sodium silicate and the mixture is rammed about a pattern. When CO2 gas is pressure-fed into the mold, the sand mixture hardens. Very smooth and intricate castings are obtained. Used for core making.

Metal molds: these are used mainly in the die-casting of low-molting-temperature alloys. Accurate with smooth finish. Eliminate much machine work.

Special molds: Plastics, cement, plaster, paper, wood and rubber are all mold materials used to fit particular applications.

Molding processes

Bench molding: is for small work, done on a bench of a height convenient to the molder.

Floor molding: When castings increase in size, with resultant difficulty in handling, the work is done on the foundry floor. This type of molding is used for practically all medium and large size castings.

Pit molding: Extremely large castings are frequently molded in a pit instead of a flask. The pit acts as the drag part of the flask and a separate cope is used above it. The sides of the pit are brick kind, and on the bottom there

Machine molding: Machines have been developed to do a number of operations that the molder ordinarily does by hand. Ramming the sand, rolling the mold, forming the gate and drawing the pattern can be done by these machines.

Mold preparation

For removable pattern:

The pattern is placed on a molding board.

The drag is placed on the board with pins down.

Molding sand is then riddled in to cover the pattern.

The sand is pressed around the pattern until the drag is completely filled.

The sand is firmly packed by the drag rammer.

After ramming the excess sand is leveled off with a straight bar called a **strike rod**.

Small vent holes are made through the sand to within a fraction of an inch of the pattern to insure the escape of gases.

The drag is then turned over so that the cope may be placed in position.

Before turning a little sand is sprinkled over the mold and a bottom board is placed on top. After rolling over the drag the molding board is removed exposing the pattern.

The surface of the sand is smoothed over with a trowel and covered with a fine coating of dry parting sand.

The cope is then placed on the drag, the pins on either side holding it in proper position.

To provide, a place for the iron to enter the mold, a tapered pin known as sprue pin is placed an inch to one side of the pattern.

The operations of filling, ramming, and venting the cope proceed in the same manner as in the drag.

The sprue pin is withdrawn, and funnel shaped opening is scooped out at the top so that there will be a fairly large opening in which to pour the metal.

The cope half of the flask is then carefully lifted off and set to one side.

Before the pattern is withdrawn, the sand around the edge of the pattern is usually moistened with a swab so that the edges of the mold hold firmly together when the pattern is withdrawn.

To loosen the pattern, a draw spike, is driven into it and rapped lightly in all directions.

The pattern is withdrawn by lifting the draw spike.

Before closing, a small passage, known as a gate must be cut between the cavity and the sprue opening.

Sometimes a hollow, known as **riser** is provided in the cope to supply hot metal as the casting cools and shrinks.

The mold surfaces may be sprayed, swabbed, or dusted with coating materials such as silica flour and graphite.

For disposable pattern:

The pattern, usually one piece, is placed on a board and the drag is molded in the conventional way.

Vent holes are added and the drag is turned over for molding the cope.

No parting sand is applied for the cope and drag will not be separated until the casting is removed.

The polystyrene pattern, including the gating and pouring system are left in the mold.

Molten metal is poured rather rapidly into the sprue, the polystyrene vaporizes and the metal fills the remaining cavity.

The mold is poured fast enough to prevent combustion of polystyrene, with the resulting carbonaceous residue. The gases due to vaporization of the material are driven out through the permeable sand and vent holes.

Gating System

The passage way for bringing the molten metal into the mold cavity. It includes: pouring basin, downgate or vertical passage known as a sprue, gate through which the metal flows from the sprue base to the mold cavity, a runner in large castings, which takes the metal from the sprue base and distributes it to several gate passage ways around the cavity.

Characteristics of good gating system:

Metal should enter the cavity with as little turbulence as possible at or near the bottom of the mold cavity.

Erosion of the passageway or cavity surfaces should be avoided by properly regulating the flow of metal.

Metal should enter the cavity so as to provide, directional solidification if possible. The solidification should progress from the mold surfaces to the hottest metal so that there is always hot metal available to compensate for shrinkage.

Clay or other foreign particles should be prevented from entering the mold cavity.

Skimming gates may be used to trap slag or other light particles into the second sprue hole. The gate to the mold is restricted somewhat to allow time for the floating particles to rise into the skimmer.

Three types of gate are used in mold:

Parting gates

Top gates

Bottom gates

Top gate: Conducive to a favorable temperature gradient but erosion may be high

Bottom gate: Offers smooth flow with a minimum of erosion but unfavorable temperature gradient.

Riser: Risers are often provided in molds to feed molten metal into the main cavity to compensate for the shrinkage.

There are two types of riser

Open Riser: Top of the open riser in open, it is cylinder shape

Advantages: An open riser is easy to mold,
Air can be removed from it.

Disadvantages: It is not placed in the drag.
More difficult to remove from the Casting.

Close/blind riser: Blind risers are dome-like risers, found in the cope half of the flask, which are not the complete height of the cope.

Advantages: Can be placed at any position of the mold
Can be easily removed from the casting.

Disadvantages: Difficult to mold
May draw liquid metal from solidifying casting.

Chills:

Chills are metal inserts used to control solidification by carrying heat away from the solidifying metal at a rapid rate.

Chills are the metal shapes inserted in molds to speed up the solidification of a particular portion of the casting.

Chills equalize the cooling rate of thin and thick sections and thus prevent hot tears.

Chills promote progressive and directional solidification.

Types of chills (I) External (II) Internal.

External Chills: It is rammed up in the mold walls. An external chill is excellent for controlling cooling rates in critical regions of castings.

Internal Chills: These are of the same material as the molten metal. Thus they are placed in the mold cavity before casting when molten metal enters into the mold cavity, it melts the block, which is used as an internal chill, and prevents shrinkage void.

Patterns:

Used to mold the sand mixture into the shape of the casting.

Patterns Materials:

Wood – for small production (white pine, mahogany, cherry etc.)

Metal – for high quality production

Brass

Cast iron

Aluminium

Plastics

Advantage of metal or plastic pattern:

Do not absorb moisture

Strong and dimensionally stable

Smooth surface finish.

Pattern material selection depends on :

The size and shape of the casting

The dimensional accuracy

The quantity of castings required

The molding process to be used.

Strength and durability of the material selected for patterns must reflect the number of castings that the mold will produce.

Sometimes combination of materials is used to reduce wear in critical regions.

Patterns are usually coated with a partings agent to facilitate their removal from the molds.

Types of pattern

Solid or single piece pattern: generally used for simpler shapes and low quantity production. They are generally made of wood and are inexpensive.

Split pattern: many patterns cannot be made of a single piece because of the difficulty in molding. To eliminate the difficulty the patterns are made split, half rests in lower part and half in upper part.

Gated patterns: in production work where many castings are required, patterns are made of metal to give them strengths and to eliminate any warping tendency. The gates or runners for the molten metal are formed by connecting parts between the individual patterns.

Loose piece pattern: consists of loose pieces, which are necessary to facilitate withdrawing it from the mold.

Match plates: provide a substantial mounting for patterns. It consists of a flat metal or wooden plate to which the patterns and gate are permanently fastened.

Sweep pattern: they are used where the shape to be molded can be formed by the rotation of a curved line element about an axis:

Rapid prototyping:

A recent development to mold and pattern making

For example, in investment casting wax patterns can now be replaced with accurate resin patterns by rapid prototyping.

In this case CAD data are used directly (without the need for dies) to make the pattern at a fraction of the time and cost of dies for making wax patterns.

Pattern allowances:

Shrinkage: metals shrink when they cool.

	Cast iron	-	} 1/8 inch/foot 3/16 inch/foot + ve allowance. 5/32 inch/foot
	Brass	-	
Steel	-	1/4 inch/foot	
	Aluminium	-	
	and Magnesium		

Draft: When a pattern is drawn from a mold, the tendency to tear away the edges of the mold in contact with the pattern is greatly decreased if the surfaces of the pattern are slightly tapered known as draft.

1/8 to 1/4 in/foot (exterior)

3/4 in/foot (interior)

Finish: positive allowance is provided for machining. For small and average-sized casting finish allowance is 1/8 inch.

Distortion: distortion allowance applies only to those castings of irregular shape which are distorted in the process of cooling because of metal shrinkage.

Shake: when a removable pattern is rapped in the mold before it is withdrawn, the cavity in the mold increases slightly. A shake allowance should be considered by making the pattern slightly smaller to compensate for the rapping of the mold.

Cores

Cores are utilized for castings with internal cavities or passages.

A core is a body, usually made of sand, used to produce a cavity in or on a casting.

Examples: forming the water jacket in a water cooled engine block and forming the air space between the cooling fins of an air cooled engine.

Cores are placed in the mold cavity before casting to form the interior surfaces of the casting.

Desirable properties:

- Strength (green and dry)
- Permeability
- Ability to withstand heat or refractoriness
- Collapsibility
- Friability

A minimal tendency to generate gas

Core making

Core sand is placed in a core box. It can be blown into the box, rammed or packed by hand, or jolted into the box. The excess sand is struck off, and a drier plate is placed over the box. The core box is then inverted, vibrated or rapped, and drawn off the core. The core is then put in a core oven and baked.

Core prints

Recesses that are added to the pattern to support the core and to provide vents for the escape of gases.

Core shifting: shifting of cores from its proper place is a major cause of defective castings.

Anchor: a core is subjected to an appreciable buoyant force when immersed in the liquid metal poured into the mold cavity.

Chaplets: serve to support cores that tend to sag or sink in inadequate core print seats. Chaplets also serve as anchor to keep the core in place during the casting process.

A chaplet is usually made of the same metal as, and becomes part of the casting.

Types of cores

Green sand core

Dry sand core

Green sand core:

A green sand core is made of the same sand from which the mold has been made i.e. the molding sand.

Relatively cheap and popular.

Dry sand core:

Dry sand core unlike green sand cores are not produced as a part of the mold.

Dry sand core is made separately and independent of the mold.

Backed sand or dry sand core has a binder that must be cured with heat.

Core making machines:

Cores of regular shapes and sections may be extruded and cut to length. A central vent hole is left by a wire extending from the center of the screw.

Large cores are made by jolt-rollover, sand slinger and other machines.

Small and medium size irregular shape cores are usually made by hand. But if quantity is high, they are produced on a core blowing machine. This machine blows sand by compressed air through a core plate with holes arranged to pack the sand evenly and firming in the core box.

Core backing:

The cores that are bonded by oils must be baked for ultimate hardness and strength. The purpose of baking is to drive off moisture, oxidize the oil, and polymerize the binder.

A uniform temperature and controlled heating are necessary for baking an oil-bonded sand core. With linseed oil the temperature is raised at a moderate rate, and is held at about 200°C for about 1 hr and then is allowed to fall slowly to room conditions.

Molding machines:

Serve: To pack sand firmly and uniformly into the mold.

To manipulate the flasks, mold, and pattern.

Three types of molding machines are:

Jolt-squeeze Molding Machine

Jolt-rollover Molding Machine

Sand slinger

Jolt-squeeze Molding Machines: A jolt-squeezer consists basically of a table actuated by two pistons in air cylinders, one inside the other. The mold on the table is jolted by the action of the inner piston that raises the table repeatedly and drops it down sharply on a bumper pad. Jilting packs the sand in the lower parts of the flask but not at the top. The larger cylinder pushes the table upward to squeeze the sand in the mold against the squeeze head at the top. A vibrator may be attached to the machine to loosen the pattern to remove it easily without damaging the mold.

The sand slinger: The sand slinger achieves a consistent packing and ramming effect by hurling sand into the mold at a high velocity. Sand from a hopper is fed by a belt to a high-speed impeller in the head. A common arrangement is to suspend the slinger with counter weights and move it about to direct the stream of sand advantageously into a mold. Sand slinger can be deliver large quantities of sand rapidly and are specially beneficial for ramming big molds.

Casting defects:

Blow holes

Gas holes

Seam and plate

Misrum

Cold shut

Hot tear

Shrinkage Cavities.

Blow holes: Small holes visible on the surface of the casting are called open blows where as occurring below the surface of the casting.

Causes>> High moisture in sand resulting in low permeability, very hard ramming of sand and improper venting of mold.

Gas holes: These are the holes appearing on the surface when it is machined or cut into sections.

Causes>>using faulty or poor quality metal, use excessive moist sand.

Seam and plate: - Seam is an impressed line on casting surface and plate is in the form of a layer of metal, partially separated from the main body of the casting section by scale (plate of hard material).

Causes>>Interrupted metal flow due to abrupt changes in casting section adn sharp section.

Misrun:- It is a casting that is incomplete in its outermost sections, either long the to thickness is too large or because the metal was poured with insufficient superheat.

Causes>> Too cold molten metal
Too thin casting section
Too small gates.

Cold shut: It is an interface within a casting that lacks complete fusion and is formed when two streams of liquid from two different directions come together after the leading surfaces are solidified.

Causes>> Metal lacking in fluidity.
Too small gates
Too cold molten metal.

Hot tear: Intergranular (along grain boundaries) failure at a high temperature the larger sections for intensive strain induced by solid contraction of adjacent thinner section.

Causes>> Excessive mold hardness.
High drag and hot strength of sand mold.
Too much shrinkage of metal while solidifying.
Too low pouring temp.

Shrinkage Cavities: An internal void in a casting from the volume contraction that occurs during solidification. It causes for any casting.

Design consideration

- (a) Design for minimum casting stresses
- (b) Design for solidification
- (c) Design for metal flow
- (d) Cast mold design.
- (e) Design for minimum casting.
- (f) Functional design

Design rules:

External corner should be rounded with raddi that are 10% to 20% to section thickness. By rounding corners, the resistance of ductile metal to fatigue or static stress is increased.

In Joining section of unequal sizes the raddi plays an important role, A raddi of (a) 0.1 t the resistance to fatigue stress is united (b) 1t, there is 40 to 50% more stress endurance. (c) 4t, 120% more stress endurance than that with 0/1t radius.

CENTRIFUGAL CASTING :

Since its inception at the beginning of nineteenth century several applications developed have survived commercial exploitation. The main feature of centrifugal casting that differentiates it from all other static casting processes is pouring of molten metal into a mould that is rotated during solidification. The castings produced by this process are completely free from porosity defect and are strong (at par with similar forgings). This is due to whirling out of metal towards the periphery because of centrifugal force. Lighter impurities are also removed as being lighter these remain at the center.

Features

Following are the main features of centrifugal casting process:
Process is suitable only for products, which have rotational symmetry.
General process is economical for ring shaped objects, tabular shaped objects and hollow cylinders, e.g. compressor cases, winding spools, furnace rollers etc.

No core is needed to form the bore as in static casting.
Temperature gradients during cooling can be controlled to some extent by controlling speed of rotation. Centrifugal pressures can be applied to advantage in checking premature freezing and imparting strength to the casting.

Main advantage of centrifugal casting is that the porosity free castings are obtained.

Types of Centrifugal Casting

There are several variations of centrifugal casting process. These are :

- True centrifugal casting
- Semi-centrifugal casting
- Centrifuge centrifugal casting
- True Centrifugal Casting

In true centrifugal casting process, the mould rotates about its axis. This axis of rotation can be vertical, horizontal or inclined depending upon the shape of final product. If the axis of rotation is horizontal it is called as horizontal centrifugal casting as shown in Figure 3.1 and if the axis is vertical or inclined it is called as vertical or inclined centrifugal casting as shown in Figures 3.2 and 3.3 respectively. In this the need of center core is completely eliminated. Castings produced by this method have true directional solidification. Because of directional solidification the casting thus produced is defect free without any shrinkage, which is prevalent in sand castings.

The rotation speed selection is very important, particularly in the case of horizontal axis rotational speed plays a finite role. A speed lower than the required causes slipping and raining of the metal, which will not adhere to the mould surface. A speed higher than necessary may cause hot tears on its walls.

Semi-centrifugal Casting

In the semi-centrifugal casting process the mould is not rotated as fast as in the case of true centrifugal casting process. This is because only enough force is needed to cause the molten metal to flow first to the outer rims. In this process, mould is filled from rim to hub not from bottom to top. This method is used for meeting large sized castings, which are symmetrical about their axis, e.g. gears, pulleys, spoke wheels etc. In this process, the metal is poured into central sprue, which in turn is forced outwards to the rim through hubs by centrifugal force. For hollow sections dry sand or CO₂ core is used.

Centrifuge Centrifugal Casting

This process has the widest field of application. In this similar mould cavities are arranged symmetrically about the center axis of rotation like spokes of the wheel. Therefore multiple castings can be produced in one go. Sometimes for a large number of castings steel moulding is used. It is not a purely centrifugal process as castings produced are not rotated about their own axes and pouring pressure is different for all the castings.

DIE CASTING:

Die casting involves the preparation of components by injecting molten metal at high pressures into a metallic die. It is similar to permanent mold casting in the sense that both the processes use reusable metallic dies. The pressure is generally obtained by compressed air or hydraulically and varies from 70-5000 kg/cm². Because of high pressures involved in the process, any narrow sections, complex shapes and fine surface details can be easily produced. Combination of high pressures and velocity of the injected liquid metal give a unique capacity for the production of intricate components at relatively low cost.

Dies

The die consists of two parts. One is called the stationary die or the cover die and is fixed to the die casting machine (as shown in figure). The second part called the ejector die is moved for the extraction of casting. The casting cycle starts when the two parts of the die are apart. The lubricant is sprayed on the die-cavity manually or by the auto lubrication system. The two die halves are closed and clamped. The required amount of metal is injected into the die. After the casting is solidified under pressure, the die is opened and the casting is ejected.

Die Casting Machines

- A die casting machine performs the following functions:
- Holding the two die halves firmly together.
- Closing the die.
- Injecting molten metal into the die.
- Opening the die.
- Ejecting the casting out of the die.

A die casting machine consists of four basic elements namely

Frame

Source of molten metal and molten metal transfer

Dies

Metal Injection Mechanism.

These machines are classified on the basis of injection mechanisms and are of two types:

Hot chamber Die casting, and

Cold chamber Die casting.

The main difference between these two types is that in hot chamber, the holding furnace for the liquid metal is integral with the diecasting machine, whereas in the cold chamber machine, the metal is melted in a separate furnace and then poured into the diecasting machine with a ladle for each casting cycle which is also called 'shot'.

Hot Chamber Process

In this process, a gooseneck is used for pumping the liquid metal into the die cavity. The gooseneck is submerged into the holding furnace containing the molten metal. The gooseneck is made of grey, alloy or ductile iron or of cast steel. A plunger made of alloy cast iron, which is hydraulically operated moves up in the gooseneck to uncover the entry port for the entry of liquid metal into the gooseneck. The plunger can then develop the necessary pressure for forcing the metal into the die cavity. A nozzle at the end of the gooseneck is kept in close contact with the sprue located in the cover die.

The cycle starts with the closing of the die when the plunger is in the highest position in the gooseneck, thus facilitating the filling of the gooseneck by the liquid metal. The plunger then starts moving down to force the metal in the gooseneck to be injected into the die cavity. The metal is then held at the same pressure till it is solidified. The die is opened, and any cores if present, are also retracted. The plunger then moves back returning the unused liquid metal to the gooseneck. The casting, which is in the ejector die, is now ejected and at the same time the plunger uncovers the filling hole, letting the liquid metal from the furnace to enter the gooseneck.

Air pressure required for injecting the metal into the die is that of the order of 30-45 kg/cm². Depending upon its size, this hot chamber die casting machine can produce about 60 or more castings upto 20 kg each per hour and several hundred castings per hour for single impression castings weighing a few grams.

Cold Chamber Process

The hot chamber process is used for most of the low melting temperature alloys such as zinc, lead and tin. For materials such as aluminum and brass, their high melting temperatures make it difficult to cast them by hot chamber process, because gooseneck of the hot chamber machine is continuously in contact with the molten metal. Also liquid aluminum would attack the gooseneck material and thus hot chamber process is not used with aluminum alloys. In the cold chamber process, the molten metal is poured with a ladle into the hot chamber for every shot. This process reduces the contact time between the liquid metal and the hot chamber.

The operation starts with the spraying of die lubricants throughout the die cavity and closing the die when molten metal is ladled into the hot chamber of the machine either manually or by means of an auto ladle. An auto ladle is a form of robotic device, which automatically scoops molten aluminum from the holding furnace and pours it into the die at the exact instance when required in the casting cycle. The pouring temperature can be precisely controlled with the help of auto ladle and hence the desired casting quality can be had. Then the plunger forces the metal into the die cavity and maintains the pressure till it solidifies. In the next step, the die opens. The casting is ejected. At the same time, plunger returns to its position completing the operation.

Cold chamber and hot chamber die casting differs from each other in the following respects :

Melting unit is not an integral part of the cold chamber die casting machine. Molten metal is brought and poured into the die casting machine with the help of ladles.

In case of cold chamber process high pressures tend to increase the fluidity of molten metal possessing relatively lower temperature and hence castings produced are denser, dimensionally accurate and free from blowholes.

In case of cold chamber process die components experience less thermal stresses due to lower temperature of the molten metal. However, dies are required to be made stronger in order to bear high pressures.

Cold chamber process has a longer cycle time compared to hot chamber process.

In case of cold chamber process as metal is ladled from a furnace, it may loose superheat and may cause defects such as cold shuts.

Advantages of Die Casting Process:

- Very high rates of production can be achieved.
- Close dimensional tolerance of the order of ± 0.025 mm is possible.
- Surface finish of 0.8 micron is achievable.
- Very thin sections of the order of 0.50 mm can be cast.
- Fine details may be produced.
- Less floor space is required.
- Longer die life is obtained.
- Unit cost is minimum.

Disadvantages of Die Casting Process

- Not economical for small runs.
- Only economical for non-ferrous alloys.
- Heavy castings cannot be cast. In fact, the size of the dies and the capacity of the die casting machines available limit the maximum size.
- Cost of die and die casting equipment is high.
- Die castings usually contain some porosity due to entrapped air.

Applications

The typical products made by die casting are carburetors, crank cases, magnetos, handle bar housings, parts of scooters and motor cycles, zip fasteners, head lamp bezels, and other decorative automobile items.

SHELL MOULDING :

Shell moulding is a process in which the sand mixed with a thermosetting resin is allowed to come in contact with a heated metallic plate, so that a thin and strong shell of mould is formed around the pattern. Then the shell is removed from the pattern and the cope and the drag are removed together and kept in a flask with the necessary backup material and molten metal is poured into the mould.

Process

Generally, dry and fine sand (90 to 140 GFN) which is completely free of the clay is used for preparing the shell moulding sand. The grain size to be chosen depends on the surface finish desired on the casting. Too fine a grain size requires large amount of resin which makes the mould expensive.

The synthetic resins used in shell moulding are essentially thermosetting resins, which get hardened irreversibly by heat. The resins, most widely used, are the phenyl formaldehyde resins. Combined with sand, they give very high strength and resistance to heat. The phenolic resins used in shell moulding usually are of the two stage type, that is, the resin has excess phenol and acts like a thermoplastic material. During coating with the sand, the resin is combined with a catalyst hexa-methylene tetramine in a proportion of about 14 to 16% so as to develop the thermosetting characteristics. The curing temperature for these would be around 150°C and the time required would be 50 to 60 sec.

Additives may sometimes be added into the sand mixture to improve the surface finish and avoid thermal cracking during pouring. Some of the additives used are coal dust, pulverized slag, manganese dioxide, calcium

carbonate, and ammonium borofluoride and magnesium silicofluoride. Some lubricants such as calcium stearate and zinc stearate may also be added to the resin sand mixture to improve the flowability of the sand and permit easy release of the shell from the pattern.

The first step in preparing the shell mould is the preparation of the sand mixture in such a way that each of the sand grain is thoroughly coated with resin. To achieve this, first the sand, hexa and additives, which are all dry, are mixed inside a Muller for a period of 1 min. Then the liquid resin is added and mixing is continued for another 3 minutes. To this cold or warm air is introduced into the Muller and the mixing is continued till all the liquid is removed from the mixture and the coating of the grains is achieved to the desired degree.

Since the sand resin mixture is to be cured at about 150°C temperature, only metal patterns with associated gating are used. The metal used for preparing patterns is grey cast iron, mainly because of its easy availability and excellent stability at temperatures involved in the process. But sometimes-additional risering provision is required as the cooling in shell mouldings is slow.

The metallic pattern plate is heated to a temperature of 200 to 350 degrees depending on the type of pattern. It is very essential that the pattern plate is uniformly heated so that the temperature variation across the whole pattern is within 25 to 40 degrees depending on the size of the pattern. A silicone agent is sprayed on the pattern and the metal plate. The heated pattern is securely fixed to a dump box, wherein the coated sand in an amount larger than required to form the shell of the necessary thickness is already filled in.

Then the dump box is rotated so that the coated sand falls on the heated pattern. The heat from the pattern melts the resin adjacent to it thus causing the sand mixture to adhere to the pattern. When a desired thickness of shell is achieved, the dump box is rotated backwards by 180 degrees so that the excess sand falls back into the box, leaving the formed shell intact with the pattern. The average shell thickness achieved depends on the temperature of the pattern and the time the coated sand remains in contact with the heated pattern.

The shell along with the pattern plate is kept in an electric or gas fired oven for curing the shell. The curing of the shell should be done as per requirements only because over curing may cause the mould to break down as the resin would burn out. The under curing may result in blow holes in the casting or the shell may break during handling because of the lack of strength.

The shells thus prepared are joined together by either mechanical clamping or adhesive bonding. The resin used as an adhesive may be applied to the parting plane before mechanical clamping and then allowed for 20 to 40 seconds for achieving the necessary bonding.

Since the shells are thin, they may require some outside support so that they can withstand the pressure of the molten metal. A metallic enclosure to closely fit the exterior of the shell is ideal, but it is too expensive and therefore impractical. Alternately, a cast iron shot is generally preferred as it occupies any contour without unduly applying any pressure on the shell. With such a backup material, it is possible to reduce the shell thickness to an economical level.

Advantages

Shell moulding castings are generally more dimensionally accurate than sand castings. It is possible to obtain a tolerance of ± 0.25 mm for steel castings and ± 0.35 mm for grey cast iron castings under normal working conditions.

A smoother surface finish can be obtained in shell castings. This is primarily achieved by the finer size grain used. The typical order of roughness is of the order of 3 to 6 microns.

Draft angles are lower than required in sand castings. The reduction in draft angles may be between 50 to 75% which considerably saves the material costs and the subsequent machining costs.

Sometimes, special cores may be eliminated in shell moulding. Since the sand has a high strength the mould could be designed in such a manner that the internal cavities can be formed directly with the shell mould itself without the need of the shell cores.

Also, very thin sections of the type of air cooled cylinder heads can be readily made by the shell moulding because of the higher strength of the sand used for shell moulding.

Permeability of the shell is high and therefore no gas inclusions occur. Very small amount of sand needs to be used.

Mechanisation is readily possible because of the simple processing involved in shell moulding.

Applications

Cylinders and cylinder heads for air cooled I. C. engines, automobile transmission parts, cast tooth bevel gears, brake beam, track rollers for crawler tractors, transmission planet carrier, steel eyes, gear blanks, chain seat bracket, refrigerator valve plate, small crank shafts are some of the common applications of shell mould castings.

UNIT II

WELDING

Welding is a materials joining process which produces coalescence of materials by heating them to suitable temperatures with or without the application of pressure or by the application of pressure alone, and with or without the use of filler material.

Welding is used for making permanent joints. It is used in the manufacture of automobile bodies, aircraft frames, railway wagons, machine frames, structural works, tanks, furniture, boilers, general repair work and ship building.

TYPES

- **Plastic Welding or Pressure Welding**

The piece of metal to be joined are heated to a plastic state and forced together by external pressure

(Ex) Resistance welding

- **Fusion Welding or Non-Pressure Welding**

The material at the joint is heated to a molten state and allowed to solidify

(Ex) Gas welding, Arc welding

Classification of welding processes:

(i). Arc welding

1. Carbon arc
2. Metal arc
3. Metal inert gas
4. Tungsten inert gas
5. Plasma arc
6. Submerged arc
7. Electro-slag

(ii). Gas Welding

1. Oxy-acetylene
2. Air-acetylene
3. Oxy-hydrogen

(iii). Resistance Welding

1. Butt
2. Spot
3. Seam
4. Projection
5. Percussion

(iv) Thermit Welding

(v) Solid State Welding

1. Friction
2. Ultrasonic
3. Diffusion
4. Explosive

(vi) Newer Welding

1. Electron-beam
2. Laser

(vii) Related Process

1. Oxy-acetylene cutting
2. Arc cutting
3. Hard facing
4. Brazing
5. Soldering

Arc welding methods

1. Metal arc welding

It is a process of joining two metal pieces by melting the edges by an electric arc. The electric arc is produced between two conductors. The electrode is one conductor and the work piece is another conductor. The electrode and the work piece are brought nearer with small air gap. (3mm app.)

When current is passed an electric arc is produced between the electrode and the work piece. The work piece and the electrode are melted by the arc. Both molten piece of metal become one. Temperature of arc is about 4000°C Electrodes used in arc welding are coated with a flux. This flux produces a gaseous shield around the molten metal. It prevents the reaction of the molten metal with oxygen and nitrogen in the atmosphere. The flux removes the impurities from the molten metal and form a slag. This slag gets deposited over the weld metal. This protects the weld seam from rapid cooling. Fig.1 shows arc welding process.

Equipments:(Refer Fig 2)

- A welding generator (D.C.) or Transformer (A.C.)
- Two cables- one for work and one for electrode
- Electrode holder
- Electrode
- Protective shield
- Gloves
- Wire brush
- Chipping hammer
- Goggles

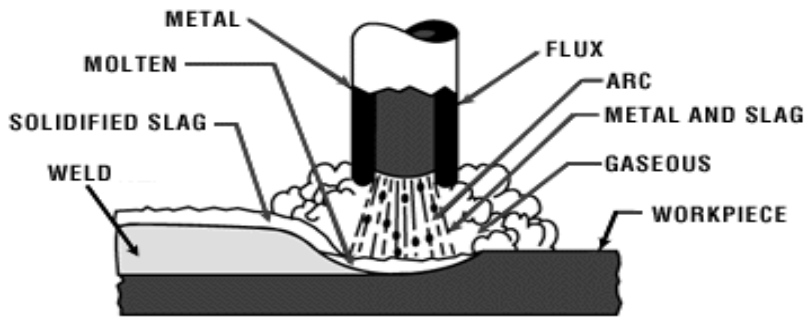

STICK WELDING PROCESS

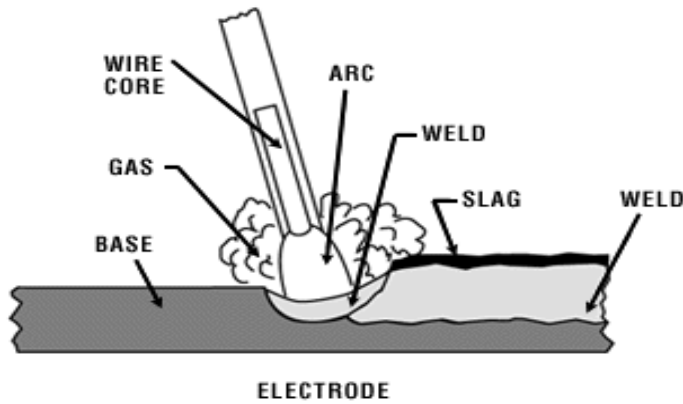

Fig. 1 Arc Welding

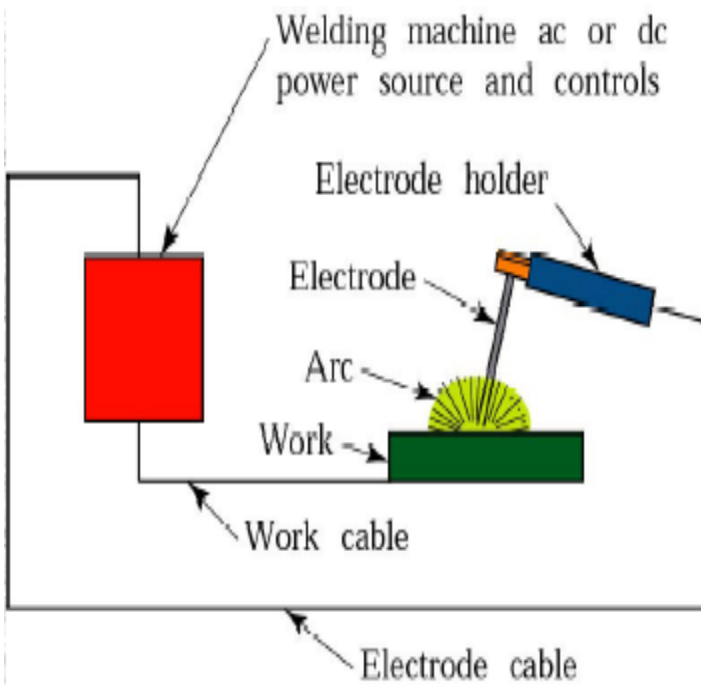

Fig 2 Electric Arc Welding

Equipments

Advantages

- Most efficient way to join metals
- Lowest-cost joining method
- Affords lighter weight through better utilization of materials
- Joins all commercial metals
- Provides design flexibility

Limitations

1. Manually applied, therefore high labor cost.
2. Need high energy causing danger
3. Not convenient for disassembly.
4. Defects are hard to detect at joints.

2. Carbon arc welding

In carbon arc welding, the intense heat of an electric arc between a carbon electrode and work piece metal is used for welding. DC power supply is used. The carbon electrode is connected to negative terminal and work piece is connected to positive terminal, because positive terminal is hotter (4000°C) than the negative terminal (3000°C) when an arc is produced. So carbon from the electrode will not fuse and mix up with the metal weld. If carbon mixes with the weld, the weld will become weak and brittle. To protect the molten metal from the atmosphere the welding is done with a long arc. In this case, a carbon monoxide gas is produced, which surrounds the molten metal and protects it.

Carbon arc welding is used to weld both ferrous and non ferrous metals. Sheets of steel, copper alloys, brass and aluminium can be welded in this method.(Refer Fig 3)

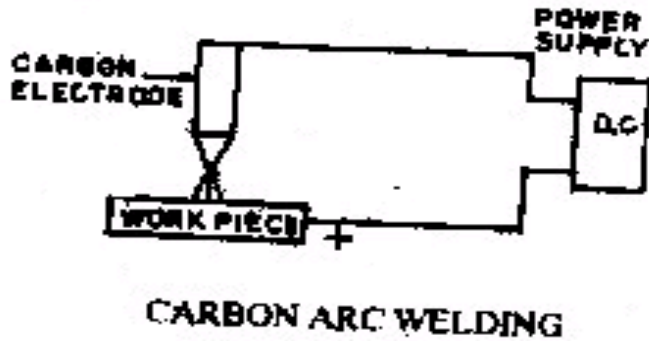

Fig 3 Carbon Arc Welding

Comparison of A.C. and D.C. arc welding

	Alternating Current (from Transformer)	Direct Current (from Generator)
1	More efficiency	Less efficiency
2	Power consumption less	Power consumption more
3	Cost of equipment is less	Cost of equipment is more
4	Higher voltage – hence not safe	Low voltage – safer operation
5	Not suitable for welding non ferrous metals	suitable for both ferrous non ferrous metals
6	Not preferred for welding thin sections	preferred for welding thin sections
7	Any terminal can be connected to the work or electrode	Positive terminal connected to the work Negative terminal connected to the electrode

GAS WELDING

Oxy-Acetylene welding

In gas welding, a gas flame is used to melt the edges of metals to be joined. The flame is produced at the tip of welding torch. Oxygen and Acetylene are the gases used to produce the welding flame. The flame will only melt the metal. A flux is used during welding to prevent oxidations and to remove impurities. Metals 2mm to 50mm

thick are welded by gas welding. The temperature of oxyacetylene flame is about 3200°C. Fig 3 shows Gas welding equipments.

Gas Welding Equipment

1. Gas Cylinders

Pressure

Oxygen – 125 kg/cm²

Acetylene – 16 kg/cm²

2. Regulators

Working pressure of oxygen 1 kg/cm²

Working pressure of acetylene 0.15 kg/cm²

Working pressure varies depends upon the thickness of the work pieces welded.

3. Pressure Gauges

4. Hoses

5. Welding torch

6. Check valve

7. Non return valve

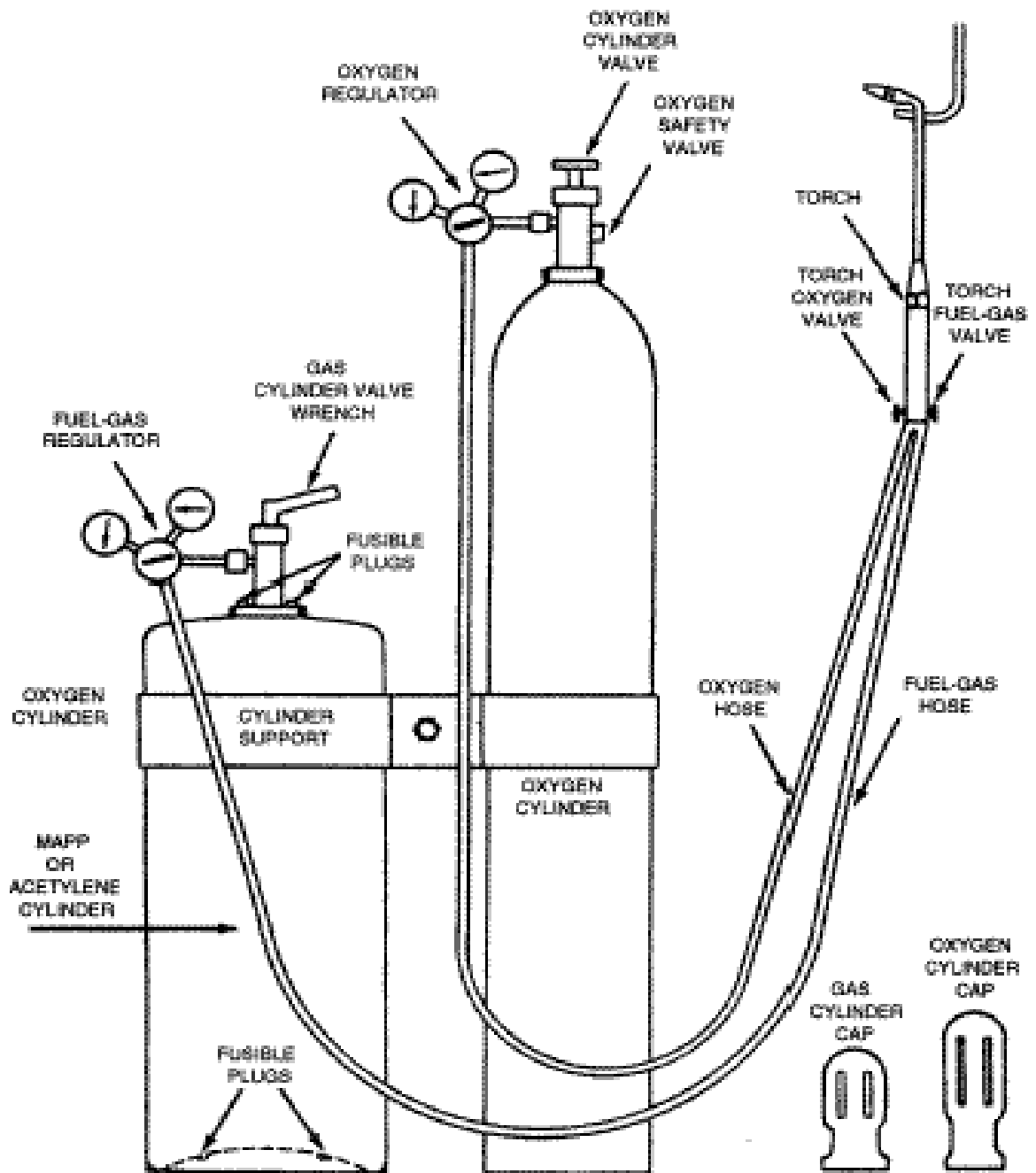

Fig- 4 Gas Welding Equipment

TYPES OF FLAMES

- When acetylene is burned in air, it produces a yellow sooty flame, which is not enough for welding applications

- Oxygen is turned on, flame immediately changes into a long white inner area (Feather) surrounded by a transparent blue envelope is called **Carburizing flame** (30000c)
- This flames are used for hardening the surfaces
- Addition of little more oxygen give a bright whitish cone surrounded by the transparent blue envelope is called **Neutral flame** (It has a balance of fuel gas and oxygen)
- Most commonly used flame because it has temperature about 32000c
- Used for welding steels, aluminium, copper and cast iron
- If more oxygen is added, the cone becomes darker and more pointed, while the envelope becomes shorter and more fierce is called **Oxidizing flame**
- Has the highest temperature about 34000c
- Used for welding brass and brazing operation

Fig 4 shows the types of flames.

(a) Neutral flame

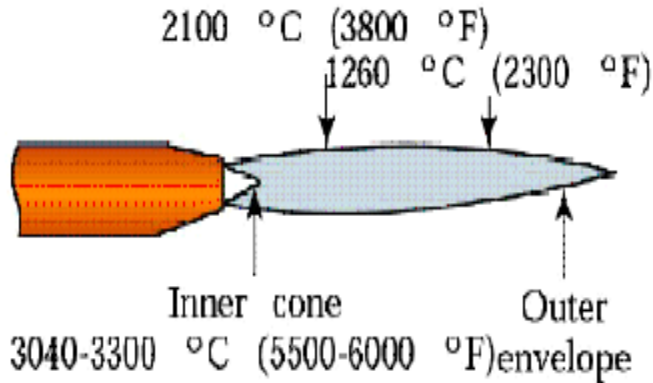

(b) Oxidizing flame

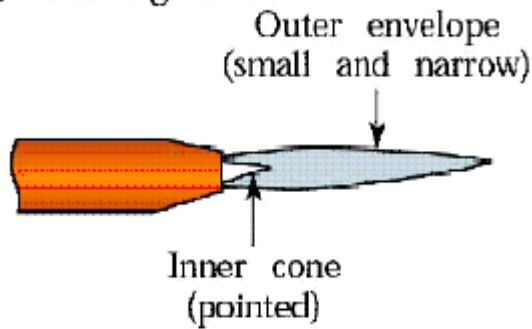

(c) Carburizing (reducing) flame

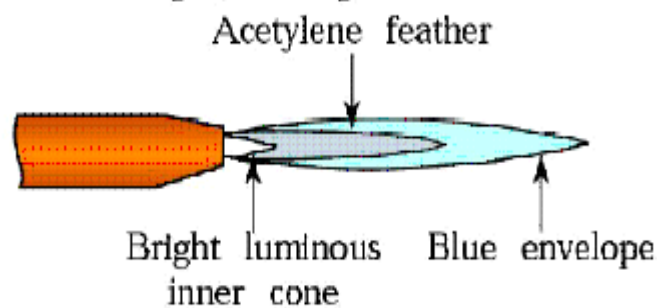

Fig 5 Types of Gas Flames

Advantages

1. Equipment has versatile
2. Same equipment can be used for oxy acetylene cutting and brazing by varying the torch size
3. Heat can controlled easily

Disadvantages

1. Slower process
2. Risk is involved in handling gas cylinders

GAS CUTTING

- Ferrous metal is heated in to red hot condition and a jet of pure oxygen is projected onto the surface, which rapidly oxidizes
- Oxides having lower melting point than the metal, melt and are blown away by the force of the jet, to make a cut

- Fast and efficient method of cutting steel to a high degree of accuracy
- Torch is different from welding
- Cutting torch has preheat orifice and one central orifice for oxygen jet
- **PIERCING** and **GOUGING** are two important operations
- **Piercing**, used to cut a hole at the centre of the plate or away from the edge of the plate
- **Gouging**, to cut a groove into the steel surface



Fig 6 Automatic Gas Cutting



Fig 7 Manual Gas Cutting

Weld joint

There are 5 basic joint types in welding

- Butt joint: Two materials are in the same plane, joined from the edges.
- Corner joint: The corners of two materials form a right angle and joined.
- Lap joint: Two parts overlaps.
- Tee joint: One part is perpendicular to the other, making a T shape.
- Edge joint: Edges of the two materials joined.

Types of weld

1. Fillet weld: Used in T joints, corner joints, lap joints.
2. Groove weld: Used in butt joints.
3. Plug weld: Used in lap joints.
4. Slot weld: Used in lap joints.
5. Spot weld: Used in lap joints.
6. Seam weld: Used in lap joints.
7. Flange weld: Used in edge joints.
8. Surfacing weld: Not a joining process, it is used to increase the thickness of the plate, or provide a protective coating on the surface.

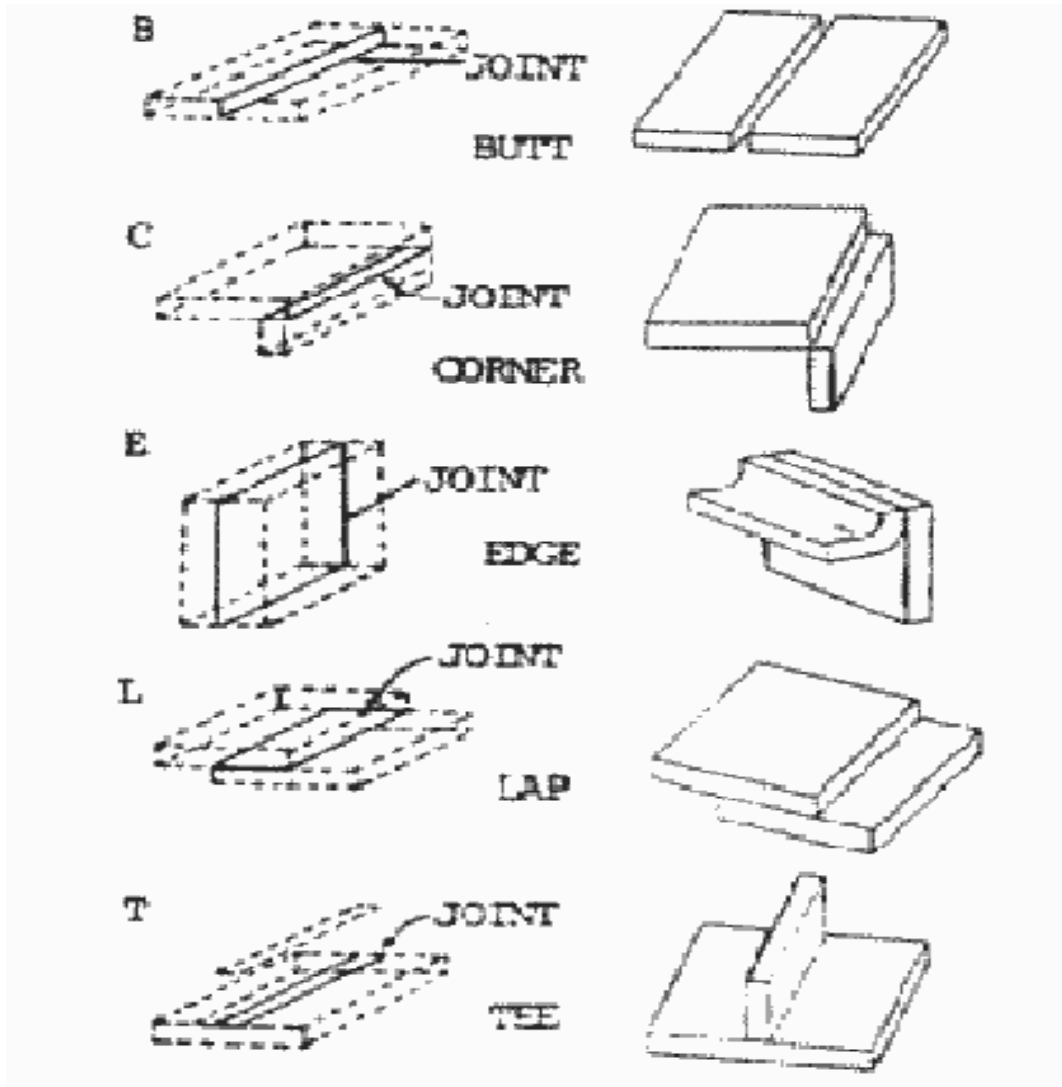

Fig 8 Types of Weld Joints

Weldability is the ease of a material or a combination of materials to be welded under fabrication conditions into a specific, suitably designed structure, and to perform satisfactorily in the intended service

Brazing and Soldering

Brazing

It is a low temperature joining process. It is performed at temperatures above 840° F and it generally affords strengths comparable to those of the metal which it joins. It is low temperature in that it is done below the melting point of the base metal. It is achieved by diffusion without fusion (melting) of the base

Depending upon the method of heating, brazing can be classified as

1. Torch brazing
2. Dip brazing
3. Furnace brazing
4. Induction brazing

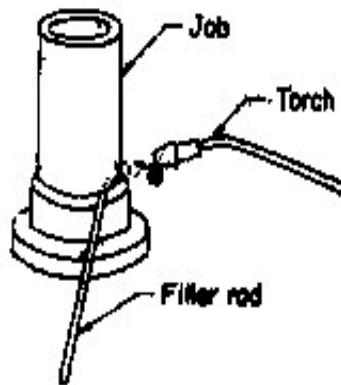

BRAZING

Fig 9 Brazing

Advantages

- Dissimilar metals which cannot be welded can be joined by brazing
- Very thin metals can be joined
- Metals with different thickness can be joined easily

- In brazing thermal stresses are not produced in the work piece. Hence there is no distortion
- Using this process, carbides tips are brazed on the steel tool holders

Disadvantages

- Brazed joints have lesser strength compared to welding
- Joint preparation cost is more
- Can be used for thin sheet metal sections

Soldering

It is a low temperature joining process. It is performed at temperatures below 840°F for joining.

Soldering is used for,

- Sealing, as in automotive radiators or tin cans
- Electrical Connections
- Joining thermally sensitive components
- Joining dissimilar metals

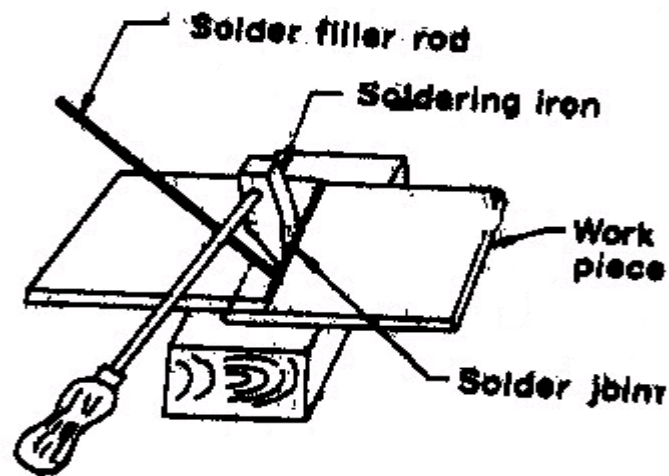

Fig 9 Soldering

Questions:

PART A – Short Questions

1. Define the term welding.
2. What is plastic welding? Give some examples.
3. What is fusion welding? Give some examples.
4. Name few gases used in welding.
5. What is the function of regulator in gas welding?
6. What is carburizing flame?
7. What is neutral flame? Write down its temperature.
8. List out the advantages of gas welding.
9. List the different equipments and accessories used in electric arc welding.
10. What is torch brazing?

PART B - Essay Type Questions

1. Classify the welding process.
2. Explain the principle of arc welding process.
3. Compare the use of A.C and D.C. in welding.
4. What are the equipments used in gas welding? State their functions.
5. What is brazing? Describe briefly two methods of brazing.
6. Write short notes on the following:
 - a. Gas cutting
 - b. Soldering
7. With a neat sketch, explain metal arc welding process.
8. With a neat sketch, explain different types of flames used in gas welding process. Also list out their uses.

UNIT III

LATHE

Definition

Lathe is a machine, which removes the metal from a piece of work to the required shape and size

Common types of lathes:

Engine Lathe:

The most common form of lathe, motor driven and comes in large variety of sizes and shapes.

Bench Lathe:

A bench top model usually of low power used to make precision machine small work pieces.

Tracer Lathe:

A lathe that has the ability to follow a template to copy a shape or contour.

Automatic Lathe:

The lathe in which the work piece is automatically fed and removed without use of an operator. Cutting operations are automatically controlled by a sequencer of some form.

Turret Lathe:

The lathes which have multiple tools mounted on turret either attached to the tailstock or the cross-slide, which allows for quick changes in tooling and cutting operations.

Computer Controlled Lathe:

Highly automated lathes, where cutting, loading, tool changing, and part unloading are automatically controlled by computer coding.

The figure (1) shows **Photographic view of Engine Lathe**

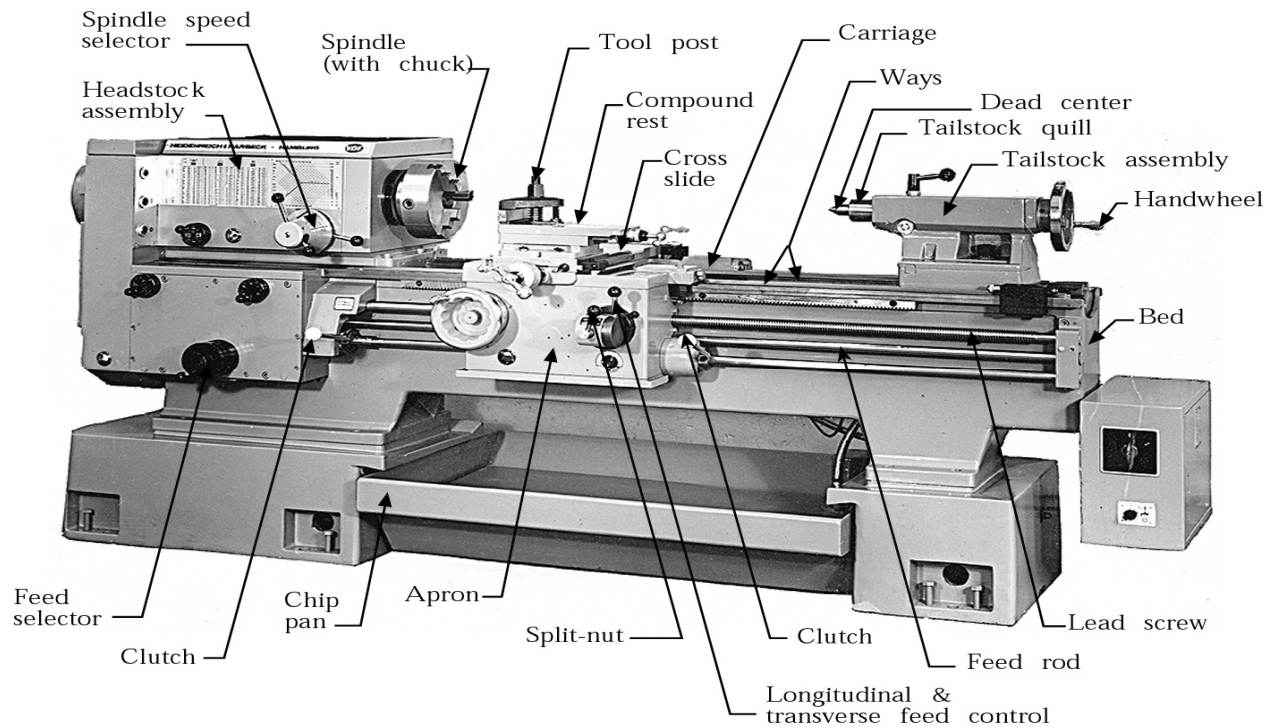

Fig (1) Engine Lathe

Centre lathe – constructional features

- Head stock
- Tail stock
- Bed
- Carriage
- Feed rod
- Lead screw
- Feed change gear box

Lathe specifications

- Distance between centers
- Swing over the bed
- Swing over the cross slide
- Horse power of the motor
- Number of speeds

- Number of feeds

Lathes and Lathe Operations

- Lathes are the oldest machine tools
- Lathe Components
 - Bed: supports all major components
 - Carriage: slides along the *ways* and consists of the *cross-slide, tool post, apron*
 - Headstock – Holds the jaws for the work piece, supplies power to the jaws and has various drive
Speeds
 - Tailstock – supports the other end of the work piece
 - Feed Rod and Lead Screw – Feed rod is powered by a set of gears from the headstock

LATHE BED

- The bed is the base of the lathe and supports all the major components of lathe.
- Lathe bed material made of grey cast iron , to resist deflection and absorb vibrations during cutting

Carriage Feed

- Longitudinal Feed or “Turning” - The tool is fed *along* the work.
- Cross Feed or “Facing” – The tool is fed *across* the work.

Tail Stock:

It's like a stationary drill press

It is centered with your work piece

For drilling use a drill chuck that fits your bits

Jam the drill chuck into the tail stock

To remove the chuck turn the tail stock back to zero and the chuck should pop out

Cutting Tools

There are basically two types of cutting tools:

- Single point (e.g. turning tools). (fig .2)
- Multiple point (e.g. milling tools).

Fig (2) shows single point cutting tool

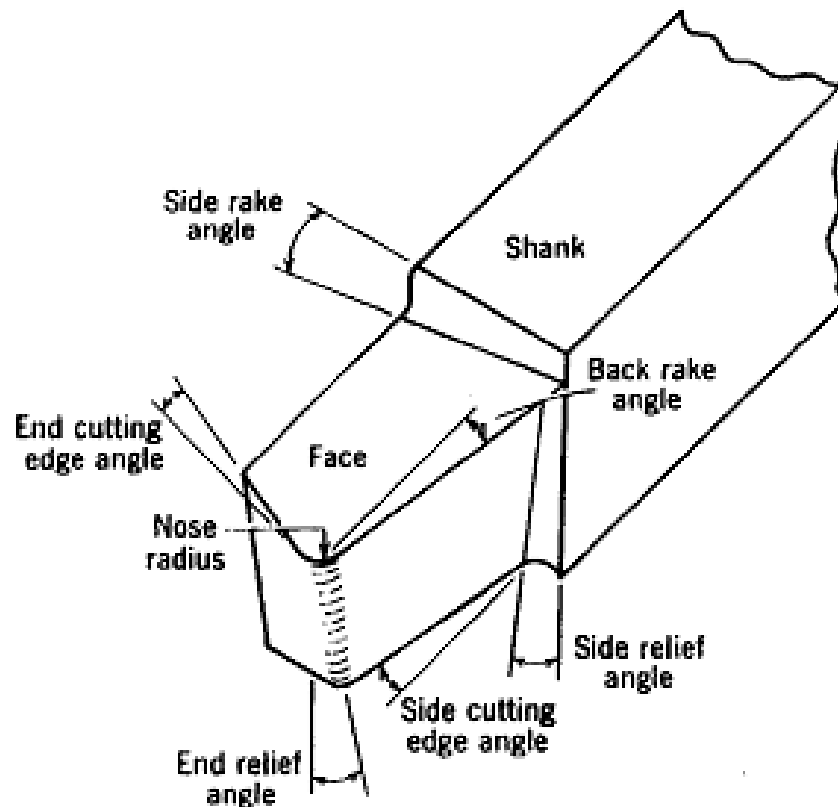

Fig (2)

Various lathe operations

- Turning – produces straight, conical, curved, or grooved work pieces
- Facing – produces a flat surface at the end of the part
- Boring – to enlarge a hole

- Drilling - to produce a hole
- Cutting off – to cut off a work piece
- Threading – to produce threads
- Knurling – produces a regularly shaped roughness

Fig (3) shows different types of lathe operations

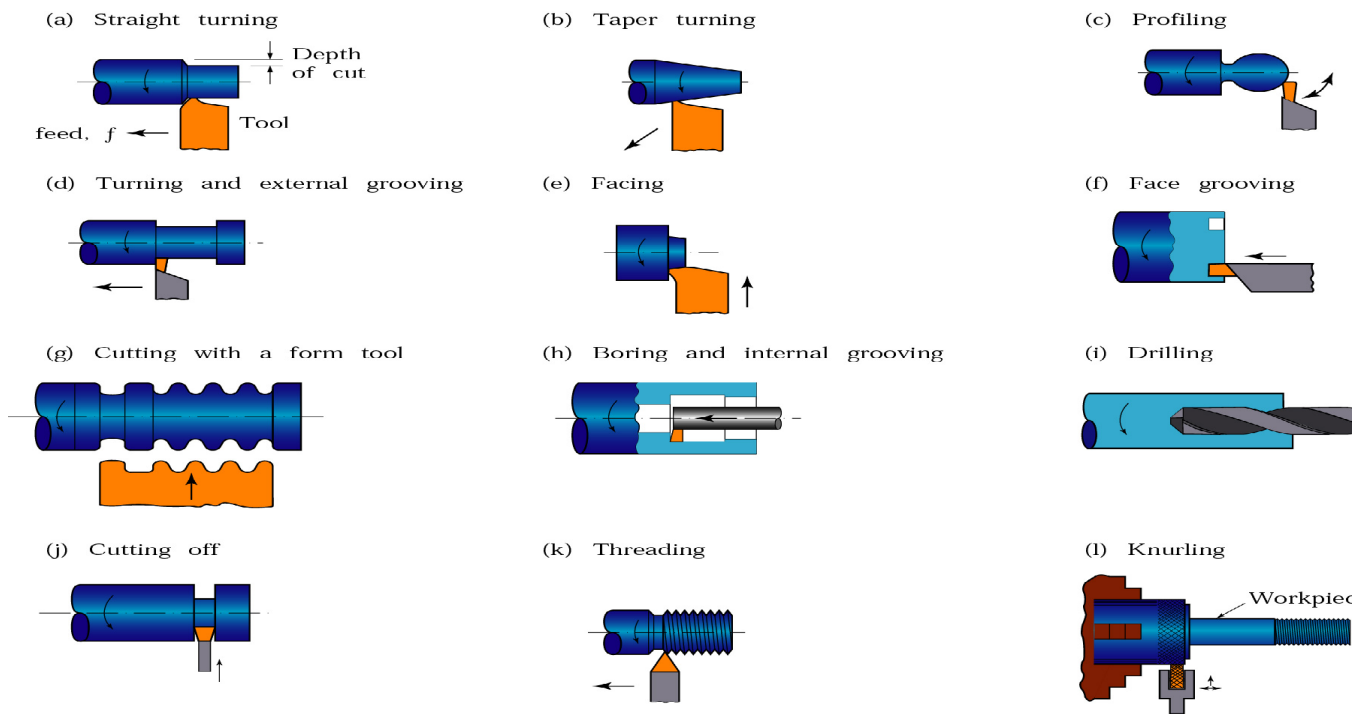

Fig (3) Types of Lathe operations

Work holding Devices for Lathes:

Many different devices, such as chucks, collets, faceplates, drive plates, mandrels, and lathe centers are used to hold and drive the work while it is being machined on a lathe.

Work pieces can be held by various methods

- Work piece mounted between centers
- Work piece mounted within a single chuck
- Work piece mounted within a collet
- Work piece mounted on a faceplate

Three Jaw chuck: It usually has three jaws, the jaws are moved simultaneously within the chuck (fig.4).

Four Jaw chuck: This is independent chuck generally has four jaws , which are adjusted individually on the chuck face by means of adjusting screws(fig.5).

Magnetic chuck: Thin jobs can be held by means of magnetic chucks.

Face plates: The face plate is used for irregularly shaped work pieces that cannot be successfully held by chucks or mounted between centers (fig.6).

Mandrels: A work piece which cannot be held between centers because its axis has been drilled or bored and which is not suitable for holding in a chuck or against a faceplate is usually machined on a mandrel.

Collet chuck : Collet chuck is used to hold small work pieces.

3 JAW CHUCK

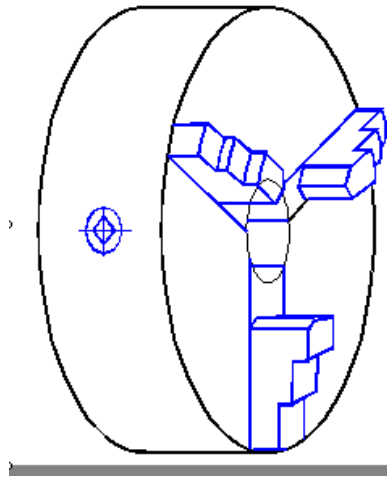

Fig.(4)

4 JAW CHUCK

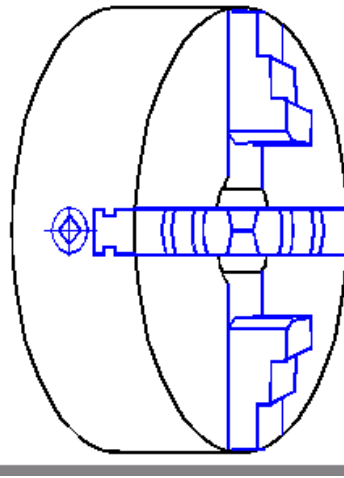

Fig.(5)

FACE PLATE

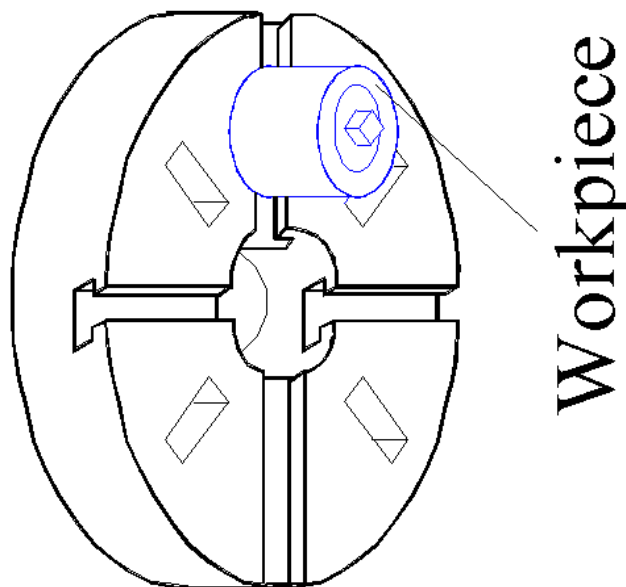

Fig.,6 Face plate

Formulas:

$$\text{Cutting speed (V)} = \frac{\pi D N}{1000} \text{ M/min}$$

$$\text{Depth of cut (D)} = \frac{(D_1 - D_2)}{2} \text{ mm}$$

Where D_1 =original diameter and D_2 = final diameter of the work piece

Metal Removal Rate (MRR) = $\Pi \times D \times d \times f$ mm³

In terms of cutting speed (V in mm/min), $MRR=1000 \times V \times d \times f$

Where D represents original diameter of the work piece in mm

Where N represents revolution per minute (rpm)

Where d represents depth of cut in mm

Where f represents feed in mm/rev

Taper Turning

$\tan \alpha = (D_1 - D_2)/2L$ where α = angle of taper

D_1 = major diameter in mm

D_2 = minor diameter in mm

L= Length of taper in mm

The Conicity K of the taper is defined as $K= (D_1 - D_2)/L$

(Part-A)

1. What do you mean by lathe?
2. What are all the various operations can be performed on a lathe?
2. What are all the principle parts of the lathe?
3. Difference between three jaw chuck and four jaw chuck
4. State the various parts mounted on the carriage?
5. write four types of tool post
6. What is an apron?
7. State any two specification of lathe?
8. List any four types of lathe?
9. What do you mean by semi-automatic lathe?
10. State the various feed mechanisms used for obtaining automatic feed?
11. List any four holding devices?
12. What are the different operations performed on the lathe?
13. State any two specifications of capstan lathe & turret lathe?
14. Compare the advantage of capstan lathe & turret lathe?
15. Define tooling?
16. What are the three stage of a tool-layout?
17. What are the different drives used in copying lathe?
18. What are the components that can be turned on a copying lathe?
19. Define automatic lathes.

Unit V

Powder Metallurgy

Powder Metallurgy → the name given to the process by which fine powdered materials are blended, pressed into a desired shape (*compacted*), and then heated (*sintered*) in a controlled atmosphere to bond the contacting surfaces of the particles and establish the desired properties.

→ it is commonly designated as *P/M*

→ it readily lends itself to the mass production of small, intricate parts of high precision, often eliminating the need for additional machining or finishing.

→ has a little material waste; unusual materials or mixtures can be utilized; and controlled degrees of porosity or permeability can be produce.

- Major areas of application tend to be those for which the P/M process has strong economical advantage or where the desired properties and characteristics would be difficult to obtain by any other method.

Basic Steps of Powder Metallurgy:

1. Powder Manufacture
2. Mixing or Blending
3. Compacting
4. Sintering

- Optional secondary processing often follows to obtain special properties or enhanced precision.

Flowchart of the Powder Metallurgy Process:

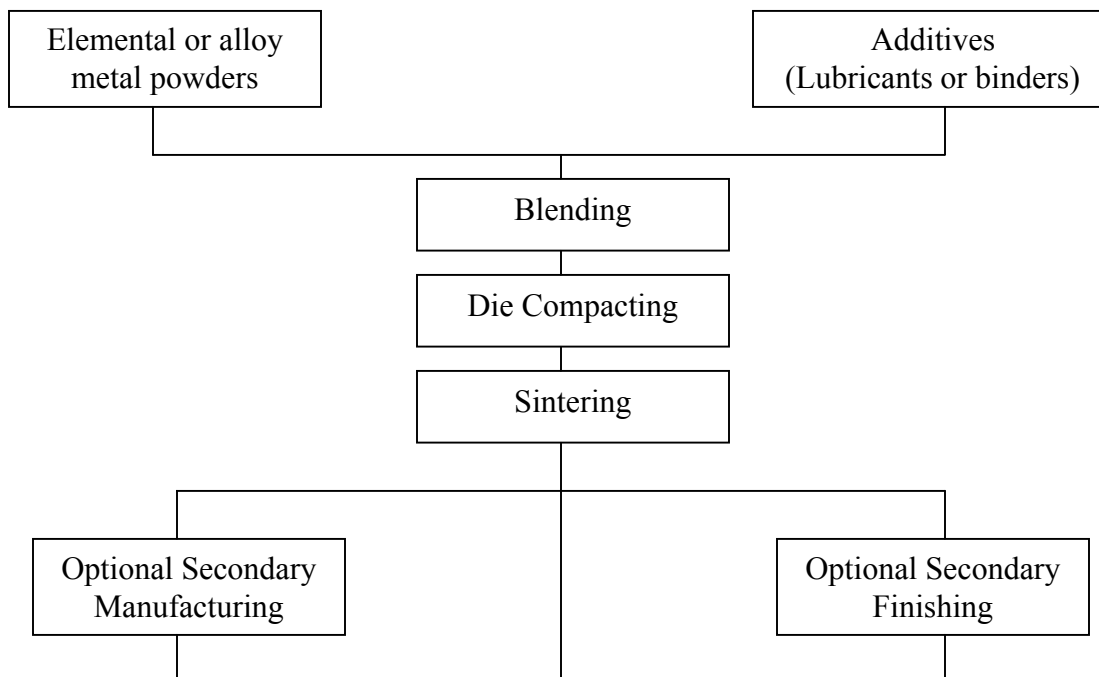

Important Properties and Characteristics of the metal or material powders that are used:

- Chemistry
- Purity
- Particle size
- Size distribution
- Particle shape
- Surface texture of the particles

2 Methods for Producing Metal Powders:

1. **Melt Atomization** → produced 80% of all the commercial powder
 - it is a process where a liquid is fragmented into molten droplets which then solidify into particles, and various forms of energy are used to form the droplets
 - a molten metal is atomized by a stream of impinging gas or liquid as it emerges from an orifice
 - an extremely useful means of producing pre-alloyed powders
2. **Atomization from a Rotating Consumable Electrode** → an electric arc impinges on a rapidly rotating electrode (*all contained within a chamber purged with inert gas*), with centrifugal force causing the molten droplets to fly from the surface of the electrode

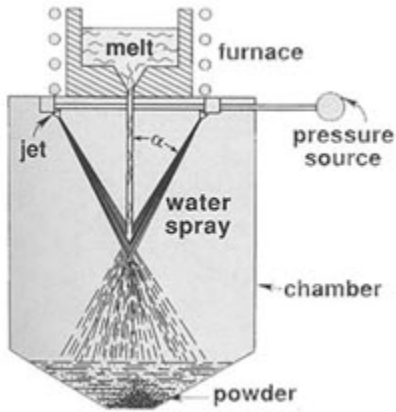

Figure 2-1: Water Atomization Process: Source "Powder Metallurgy Science" Second Edition, R.M. German, MPIF.

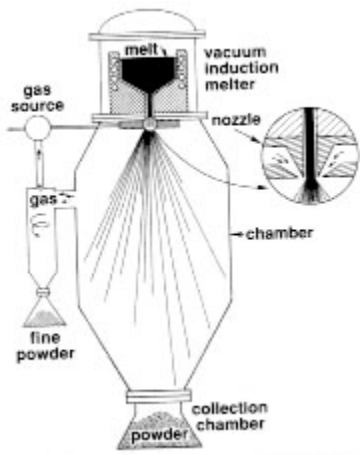

Figure 2-2: Vertical Gas Atomizer: Source "Powder Metallurgy Science" Second Edition, R.M. German, MPIF.

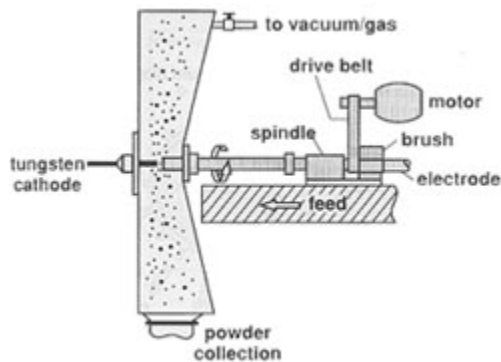

Figure 2-3: Centrifugal Atomization by the Rotating Electrode Process: Source "Powder Metallurgy Science" Second Edition, R.M. German, MPIF.

Commercial Powder that are produced :

- Aluminum alloys
- Copper alloys
- Stainless steel
- Nickel-based alloys (*such as Monel*)
- Titanium alloys
- Cobalt-based alloys
- Other low-alloy steels

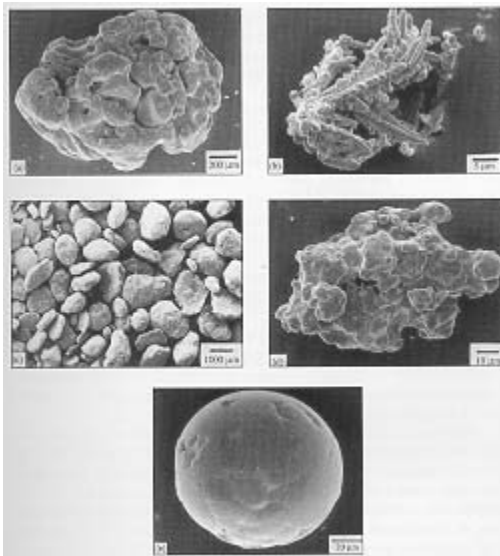

Figure 5: Representative Metal Powders: (a) Chemical; Sponge Iron-Reduced Ore; (b) Electrolytic; Copper; (c) Mechanical; Milled Aluminum Powder Containing Disperoids (17); (d) Water Atomization : Iron; (e) Gas Atomization: Nickel-Base Hardfacing Alloy.: Source "Atomization - The Production Of Metal Powders" A. Lawley, MPIF.

Process features of the powder particles that size and shape can varied and depend on :

- Velocity and media of the atomizing jets or the speed of electrode rotation

- Starting temperature of the liquid (*which affects the time that surface tension can act on the individual droplets prior to solidification*)
- Environmental provided for cooling

When cooling is slow (*such as in gas atomization*) and surface tension is high, spherical shapes can form before solidification.

Irregular shapes are produced due to more rapid cooling, such as water atomization.

Other methods of Powder Manufacture :

- Chemical reduction of particulate compounds (generally crushed oxides or ores)
- Electrolytic deposition from solutions of fused salts
- Pulverization or grinding of brittle materials (comminution)
- Thermal decomposition of hydrides or carbonyls
- Precipitation from solution
- Condensation of metal vapors

Almost any metal, metal alloy, or nonmetal like ceramic, polymer or wax or graphite lubricant can be converted into powder form by any of the methods.

Some methods can produce only elemental powder, often of high purity. While others can produce pre-alloyed particles.

Operations such as drying or heat treatment may be required prior to further processing.

Rapidly solidified powder (microcrystalline and amorphous)

Increasing the cooling rate of liquid material can result in the formation of an ultrafine or microcrystalline grain size. In these materials, a large percentage of the atoms are located in grain boundary regions, giving unusual properties, expanded alloy possibilities, and good formability. If the cooling rate approaches or exceeds 10^6 °C/sec, metals can solidify without becoming crystalline.

Production of amorphous material, however, requires immensely high cooling rates. Atomization with rapid cooling and the “splat quenching” of a metal stream onto a cool surface to produce a continuous ribbon are two prominent methods. Since much of the ribbon material is further fragmented into powder, powder metallurgy thus becomes the primary means of fabricating useful products.

Powder testing and evaluation

Flow rate is a measure of the ease by which powder can be fed and distributed into a die. Poor flow characteristics can result in nonuniform die filling and in nonuniform density and properties in a product.

Associated with the flow characteristics is the apparent density, a measure of the powder's ability to fill available space without the application of external pressure. Compressibility tests evaluate the effectiveness of applied pressure in raising the density of the powder, and green strength is used to describe the strength and fracture of resistance.

Powder mixing and blending

It is rare that a single powder will possess all of the characteristics desired in a given process and product. Most likely, a starting material will be a mixture of various grades or sizes of powder, or powders of different compositions, with additions of lubricants or binders.

Some powders, such as graphite, can even play a dual role, serving as lubricant steel. Lubricants improve the flow characteristics and compressibility at the expense of reduced green strength.

Blending or mixing operations can be done either dry or wet, where water or other solvent is used to improve mixing, reduce dusting, and lessen explosion hazards.

Compacting – one of the most critical steps in the P/M process.

Green compact – loose powder is compressed and densified into shape, usually at room temperature.

** Most compacting is done with mechanical presses and rigid tools, but hydraulic and hybrid presses can also be used.*

** Compacting pressures generally range between 3 and 120 tons/in² (40 to 1650 MPa) depending on material and application with 10 to 30 tons/in² (140 to 415 MPa) being the most common.*

** Most P/M presses have total capacities of less than 100 tons ($9 \times 10^5 \text{N}$)*

** Increasing numbers are being purchased with high capacity; as a result, powder metallurgy products are often limited to cross sections of less than 3 in² (2000mm²).*

** With increased press capacity, sections up to 10 in² (6500mm²) have become more common.*

** Metal-forming processes, such as rolling, forging, extrusion, and swagging, have also been adapted to compact powders.*

Typical Compaction Sequence for a Mechanical Press:

With the feed bottom punch in its fully raised position, a feed shoe moves up into position over the die. The feed shoe is an inverted container filled with powder, connected to the powder supply by a flexible tube. With the feed shoe in position, the bottom punch descends to a preset fill depth, and the shoe retracts, leveling the powder. The upper punch retracts and the bottom punch rises to eject the green compact. As the

die shoe advances for the next cycle, its forward edge clears the compact from the press, and the cycle repeats.

During compacting, the powder particles move primarily in the direction of the applied force.

The opposing force is probably a combination of:

1. Resistance by the bottom punch
2. Friction between the particles and the die surfaces

Compaction with a Single Punch:

** When pressure is applied at one punch, maximum density occurs below the punch and decreases as one moves down the column.*

Double-action Press:

-more uniform density can be obtained and thicker products can be compacted.

**Since sidewall friction is a key factor in compaction, the resulting density is strong function of both the thickness and width of the part being compressed. For good, uniform compaction, the ratio of thickness/width should be kept below 2.0 whenever possible.*

Effect of Compacting Pressure on Green Density:

**The average density of the compact depends on the amount of the pressure that is applied.*

Two-thickness Part with only One Punch:

- shows that a single displacement will produce different degrees compaction in different thickness of powder.
- therefore, it is impossible for a single punch to produce uniform density in multi-thickness part.

Two Methods of Compacting Two Thickness Parts to Near Uniform Density:

- by providing different amounts of motion to the various punches and synchronizing these movements to provide simultaneous compaction, a uniformly compacted product can be produced.

**Isostatic Compaction – when extremely complex shapes are desired, the powder is generally encapsulated in a flexible mold and immersed in a pressurized gas or liquid.
- production rates in this process are extremely low, but parts up to several hundred pounds can be compacted effectively.*

Compaction Tooling (Punches and Dies)

- compaction tools are usually made off harden tool steel.
- die surfaces should be highly polished and the dies should be heavy enough to withstand the high pressing pressures.
- lubricants are also used to reduce die wear.

P/M Injection Molding

- small, complex-shaped components have been fabricated from plastic for many years by means of injection molding.
- recently developed alternative to conventional powder metallurgy compaction.
- while the powdered material does not flow like a fluid: complex shapes can be produced by mixing ultrafine (usually less than 10 um) metal, ceramic, or carbide powder with a thermoplastic/wax material (up to 50% by volume).
- *A water-soluble methylcellulose binder is one attractive alternative to the thermoplastics.

Sintering

The word sinter comes from the Middle High German Sinter, a cognate of English cinder. In the sintering operation, the pressed- powder compacts are heated in a controlled – atmosphere environment to a temperature below the melting point but high enough to permit the solid-state diffusion and held for sufficient time to permit bonding of the particles. Most sintering operations involve three stage and many sintering furnaces employ three corresponding zones. The first operation, the burn-off or purge, is designed to combust any air, volatize and remove lubricants or binders that would interfere with good bonding and slowly raise the temperature of the compacts in a controlled manner. The second or the high- temperature stage is where the desired solid – state diffusion and bonding between the powder particles take place. Finally, a cooling period is required to lower the temperature of the products while maintaining them in a controlled atmosphere. These three stages must be conducted in a protective atmosphere. This is critical since the compacted shapes have residual porosity and internal voids that are connected to exposed surfaces. Reducing atmospheres, commonly based on hydrogen, dissociated ammonia, or cracked hydrocarbons, are preferred since they can reduce any oxide already present on the particle surfaces and combust harmful gases that are liberated during sintering. During the sintering operation, a number of changes occur in compact. Metallurgical bonds form between the powder particles as a result of solid-state diffusion and strength, ductility, toughness, and electrical and thermal conductivity all increase. Diffusion may also promote when different chemistry were blended.

Other techniques to produce high density P/M products

High – density P/M parts can also be produced by using high temperature forming process. Sheets of sintered powder educed in thickness and further densified by rolling. The Ceracon process is another method of raising conventional pressed –and- sintered P/M products to full density without the need for encapsulation or canning. Another

means of producing a high density shape from fine particles is in-situ compaction or spray forming.

Secondary operations

- P/M parts are ready to use after they have emerged from the sintering furnace but many products utilize one or more secondary operations to provide enhanced precision, improved properties, or special characteristics.

⇒ Secondary operations are performed to improve:

1. Density
 2. Strength
 3. Shape
 4. Corrosion Resistance
 5. Tolerances
- Any powder metallurgy process creates some porosity. MIM minimizes total porosity and typically limits interconnected porosity (that porosity connected to a free surface) to less than 0.2%, regardless of the product's percent of full density. This means standard coloring and plating techniques can be used without resin impregnation. Oil impregnation and copper infiltration are not used with MIM. When heat treated, parts can be case hardened to closely control case depths equivalent to wrought material. Other metalworking techniques such as drilling, tapping, turning, grinding, and broaching work well with MIM. All parts are barrel finished unless otherwise specified. These guidelines are not absolute, and are influenced by a number of factors related to part design.
 - A wide range of additional operations or treatments can be carried out on the parts after they have been sintered.
 1. Heat Treatment:-Sintered parts may be heat treated to increase strength and also hardness for improved wear resistance.
 2. Oil Impregnation:-The controlled porosity of P/M parts permits their impregnation with oil and resin. This operation is used to give the part self lubricating properties.
 3. Resin Impregnation :-Used to improve machinability, seal parts gas or liquid tight, or prepare the surface for plating.
 4. Machining :-All normal machining operations can be carried out on sintered components.
 5. Drilling:-Usually used for holes not in the direction of the pressing.
 6. Burr Removal:-Barrelling is used to remove burrs and sharp corners.
 7. Corrosion Resistance:-Various types of surface treatment are available to increase corrosion resistance to withstand the most demanding of environments.
 8. Finishing:-Includes, deburring, burnishing, coating oil dip, plating, welding, and mechanical surface treatments.

Properties of P/M Products

- Mechanical properties show a strong dependence on product density, with the fracture-limited properties of toughness, ductility and fatigue life being more sensitive than strength and hardness.
 - ❖ The voids in the P/M part act as stress concentrators and assist in starting and propagating fractures.
 - ❖ The yield strength of P/M products made from weaker metals is often equivalent to the same material in wrought form.
 - ❖ If higher strength materials are used or the fracture-related tensile strength is specified, the P/M properties tend to fall below those of wrought equivalents by varying but usually substantial amounts.
 - ❖ When larger presses or processes such as P/M forging or HIP are employed to produce higher density, the strength of the P/M products approaches that of the wrought material. With full density and fine grain size.
 - ❖ With full density and fine grain size. P/M parts often have properties that exceed their wrought or cast equivalents.
 - ❖ Since mechanical properties of powder metallurgy products are so dependent upon density, it is important that P/M products be designed and materials selected so that the final properties will be achieved with the anticipated amount of final porosity.
 - Physical Properties can also be affected by porosity
 - ❖ Corrosion resistance tends to be reduced due to the presence of entrapment pockets and fissures.
 - Electrical, thermal, and magnetic properties all vary with density.
- Porosity actually promotes good sound and vibration damping, and many P/M parts are designed to take advantage of this feature.

Design of Powder Metallurgy Parts

- P/M is a special manufacturing process and provision should be made for a number of unique factors. Products that are converted from other manufacturing processes without modification in design rarely perform as well as parts designed specifically for manufacture by powder metallurgy.
 - Basic rules for the design of P/M parts:
 1. The shape of the part must permit ejection from the die. Perpendicular sidewalls are preferred, and holes or recesses should be uniform in size and parallel to the axis of punch travel.
 2. The Shape of the part should be such that powder is not required to flow into small cavities such as thin walls, narrow splines, or sharp corners.
 3. The shape of the part should permit the construction of strong tooling.

4. the shape of the part should be within the thickness range for which P/M parts can be adequately compacted
5. Parts can be design with as few changes in section thickness as possible.
6. Parts can be designed to take advantage of the fact that certain forms and properties can be produced by P/M which are impossible, impractical, or uneconomical to obtain by any other method.
7. If necessary, the design should be consistent with available equipment. Pressing areas should match press capability, and the number of thicknesses should be consistent with the number of available press actions.
8. Consideration should also be made for product tolerances. Higher precision and repeatability is observed for dimensions in the radial direction (set by the die) than for those in the axial or pressing direction (set by punch movement)
9. Finally, design should consider and compensate for the dimensional changes that will occur after pressing, such as the shrinkage that occurs during sintering.

- ❖ The ideal metallurgy part has a uniform cross section and a single thickness that is small compared to the cross-sectional width or diameter.
- ❖ Complex shapes are possible but it should be remember that uniform strength and properties require uniform density.
- ❖ Designs can easily accommodate holes that are parallel to the direction of pressing.
- ❖ Holes at angles to this direction must be made by secondary processing.
- ❖ Abrupt changes in section, narrow deep flutes, and internal angles without generous fillets should be avoided.
- ❖ Punches should be designed to eliminate sharp points or thin sections that could easily wear a fracture.

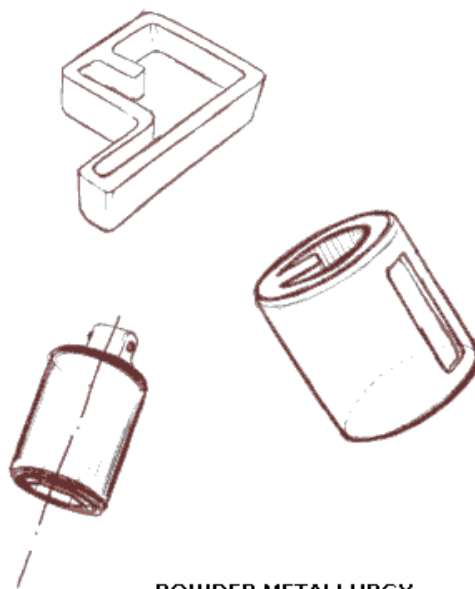

POWDER METALLURGY
(EXAMPLES)

Powder Metallurgy Products

Products that are commonly produced by powder metallurgy can generally be classified into five groups.

1. Porous or permeable products
 - Oil-impregnated bearings made from either iron or copper alloys, constitute a large volume of Powder Metallurgy products. They are widely used in home appliance, and automotive applications since they require no lubrication or maintenance during their service life. Unlike many alternative filters, they can withstand conditions of elevated temperature, high applied stress, and corrosive environments.
2. Products of complex shapes that would require considerable machining when made by other processes
 - Because of the accuracy and fine finish characteristic of the Powder Metallurgy process, many parts require no further processing and others require only a small amount of finish machining. Large numbers of small gears are made by the powder metallurgy process. Other complex shapes such as pawls, cams, and small activating levers, can be made quite economically.
3. Products made from materials that are difficult to machine or with high melting points
 - Some of the first modern uses of powder metallurgy were the production of tungsten lamp filaments and tungsten carbide cutting tools.
4. Products where the combined properties of two or more metals (or both metals and nonmetals) are desired.
 - The unique capability of the powder metallurgy process is applied to a number of products. In the electrical industry, copper and graphite are frequently combined in such applications as motor or generator brushes, copper providing the current carrying capacity, with graphite providing lubrication. Similarly, bearings have been made of graphite combined with iron or copper or of mixtures of two metals, such as tin and copper, where the softer metal is placed in a harder metal matrix. Electrical contacts often combine copper or silver with tungsten, nickel or molybdenum. The copper or silver provides high conductivity, while the material with high melting temperature provides resistance to fusion during the conditions of arcing and subsequent closure.
5. Products here the powder metallurgy process produces clearly superior properties

- The development process that produce full density has resulted in powder metallurgy products that are clearly superior to those produced by competing techniques. In areas of critical importance such as aerospace applications, the additional cost of the processing may be justified by the enhanced properties of the product. In the production of powder metallurgy products magnets, a magnetic field can be used to align the particles prior to sintering, thereby producing a high flux density in the product.

Advantages and Disadvantages of Powder Metallurgy

Advantages:

1. Elimination or reduction of machining
2. High Production Rates
3. Complex Shapes to be Produced
4. Wide Variations in Compositions are Possible
5. Wide Variation in Properties are Available
6. Scrap is Eliminated or Reduced

Disadvantages:

1. Inferior Strength Properties
2. Relatively High Die Cost
3. High Material Cost
4. Design Limitations
5. Density Variations Produce Property Variations
6. Health and Safety Hazards