

GATE 2015 –CS on 7th February, 2015 – (Afternoon Session)**General Aptitude Questions**
Q.No-1-5 Carry One Mark Each

1. Based on the given statements, select the most appropriate option to solve the given question
What will be the total weight of 10 poles each of same weight?

Statements

- (I) One fourth of the weight of a pole is 15kg.
(II) The total weight of these poles is 160 kg more than the total weight of two poles
(A) Statement I alone is not sufficient
(B) Statement II alone is not sufficient
(C) Either I or II alone is sufficient
(D) Both statements I and II together are not sufficient.

Answer: (C)

Exp: Let weight of each pole be x

I. Given, $\frac{x}{4} = 15 \text{ kg}$

$\Rightarrow x = 60 \text{ kg}$

All poles are of same weight

\therefore Weight of 10 poles = $10x = 10 \times 60 = 600 \text{ kg}$

II. Given, $10x = 2x + 160$

$\Rightarrow 8x = 160 \text{ kg} \Rightarrow x = 20 \text{ kg}$

\therefore Weight of 10 poles = $10x = 10 \times 20 = 200 \text{ kg}$

2. Consider a function $f(x) = 1 - |x|$ on $-1 \leq x \leq 1$. The value of x at which the function attains a maximum, and the maximum value of the function are.

- (A) 0, -1 (B) -1, 0 (C) 0, 1 (D) -1, 2

Answer: (C)

Exp: For $-1 \leq x \leq 1$, $0 \leq |x| \leq 1$. $f(x)$ will be maximum when $|x|$ is minimum, i.e. $|x| = 0 \Rightarrow x = 0$

\therefore Maximum value of $f(x) = 1 - 0 = 1$

3. A generic term that include various items of clothing such as a skirt, a pair of trousers and a shirt is

- (A) fabric (B) textile (C) fibre (D) apparel

Answer: (D)

Exp: apparel- clothing, especially outerwear; garments; attire; raiment

4. Choose the statement where underlined word is used correctly.
- (A) The industrialist load a personnel jet.
 (B) I write my experience in my personnel diary.
 (C) All personnel are being given the day off.
 (D) Being religious is a personnel aspect.

Answer: (C)

Exp: personnel- people employed in an organization or engaged in an organized undertaking such as military service.

5. We _____ our friend's birthday and we _____ how to make it up to him.
- (A) Completely forgot - - - don't just know
 (B) Forgot completely - - - don't just know
 (C) Completely forgot - - - just don't know
 (D) Forgot completely - - - just don't know

Answer: (C)

Q.No-6-10 Carry Two Marks Each

6. In a triangle PQR, PS is the angle bisector of $\angle QPR$ and $\angle QPS = 60^\circ$. What is the length of PS?

(A) $\frac{(q+r)}{qr}$

(B) $\frac{qr}{(q+r)}$

(C) $\sqrt{(q^2+r^2)}$

(D) $\frac{(q+r)^2}{qr}$

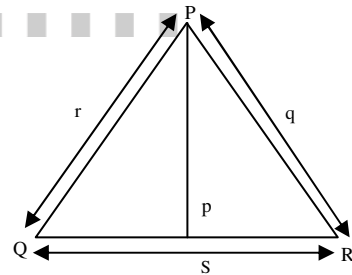

Answer: (B)

7. Out of the following four sentences, select the most suitable sentence with respect to grammar and usage.
- (A) Since the report lacked needed information, it was of no use to them.
 (B) The report was useless to them because there were no needed information in it.
 (C) Since the report did not contain the needed information, it was not real useful to them
 (D) Since the report lacked needed information, it would not had been useful to them.

Answer: (A)

Exp: (B) there **was** no needed information
 (C) not **really** useful
 (D) would not **have** been

8. If the list of letters, P,R,S,T,U is an arithmetic sequence, which of the following are also in arithmetic sequence?
- I. $2P, 2R, 2S, 2T, 2U$
 II. $P - 3, R - 3, S - 3, T - 3, U - 3$
 III. P^2, R^2, S^2, T^2, U^2
- (A) I only (B) I and II (C) II and III (D) I and III

Answer: (B)

Exp: Let us take the numbers as 3,4,5,6,7 $n=1$ and they are in arithmetic sequence

I. 6, 8,10,12,14 $n=2$ and they are in arithmetic sequence

II. 0,1,2,3,4 $n=1$ and they are in arithmetic sequence

III. 9,16,25,36,49 $n=7,9,11,13$ they are not in an arithmetic sequence

9. If p,q,r,s are distinct integers such that:

$$f(p,q,r,s) = \max(p,q,r,s)$$

$$g(p,q,r,s) = \min(p,q,r,s)$$

$$h(p,q,r,s) = \text{remainder of } (p \times q) / (r \times s) \text{ if } (p \times q) > (r \times s) \text{ or remainder of } (r \times s) / (p \times q) \text{ if } (r \times s) > (p \times q)$$

$$\text{Also a function } fgh(p,q,r,s) = f(p,q,r,s) \times g(p,q,r,s) \times h(p,q,r,s)$$

Also the same operations are valid with two variable functions of the form f(p,q)

What is the value of fg(h(2,5,7,3), 4,6,8)?

Answer: (1)

10. Four branches of a company are located at M,N,O and P. M is north of N at a distance of 4km: P is south of O at a distance of 2 km: N is southeast of O by 1 km. What is the distance between M and P in km?

- (A) 5.34 (B) 6.74 (C) 28.5 (D) 45.49

Answer: (A)

Exp:

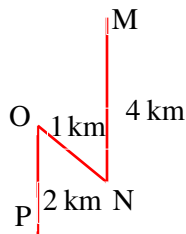

Section Name: Computer Science and Information Technology**Q.No-1-25 Carry One Mark Each**

1. An unordered list contain n distinct elements. The number of comparisons to find an element in this list that is neither maximum nor minimum is
- (A) $\Theta(n \log n)$ (B) $\Theta(n)$ (C) $\Theta(\log n)$ (D) $\Theta(1)$

Answer: (D)

Exp: Consider first three element of the list, atleast one of them will be neither minimum nor maximum

$\therefore \Theta(1)$

2. Let R be the relation on the set of positive integers such that aRb if and only if a and b are distinct and have a common divisor other than 1. Which one of the following statements about R is true?
- (A) R is symmetric and reflexive but not transitive
(B) R is reflexive but not symmetric and not transitive
(C) R is transitive but not reflexive and not symmetric
(D) R is symmetric but not reflexive and not transitive

Answer: (D)

Exp: R is not reflexive as each element can't be related to itself.

R is symmetric

Let $a = 3$, $b = 6$ and $c = 10$ then 3 and 6 have a common division other than 1

6 and 10 have a common division other than 1

but 3 & 10 have no common division other than 1

$3R6$ and $6R10$ but $3 \not R 10$

R is not transitive

3. Consider the following transaction involving two bank account x and y.
read (x) ; x : = x - 50; write (x) ; read (y); y : = y + 50 ; write (y)
The constraint that the sum of the accounts x and y should remain constant is that of
- (A) Atomicity (B) Consistency (C) Isolation (D) Durability

Answer: (B)

Exp: The consistency property ensures that the database remains in a consistent state before the (start of the transaction and after the transaction is over. Here sum of the accounts x & y should remain same before & after execution of the given transactions which refers to the consistency of the sum.

4. A binary tree T has 20 leaves. The number of nodes in T having two children is _____.

Answer: (19)

Exp: Let the number of vertices of a binary tree with 'p' leaves be n then the tree has

- (i) p vertices (i.e., leaves) of degree 1
- (ii) one vertex (i.e., root of T) of degree 2
- (iii) ' $n - p - 1$ ' (i.e., interval) vertices of degree 3
- (iv) $n - 1$ edges

∴ By Handshaking theorem,

$$p \times 1 + 1 \times 2 + (n - p - 1) \times 3 = 2(n - 1)$$

$$\Rightarrow n = 2p - 1$$

$$= 39 \text{ as } p = 20$$

∴ $n - p = 19$ vertices have exactly two children

5. Consider the basic COCOMO model where E is the effort applied in person-months, D is the development time in chronological months, KLOC is the estimated number of delivered lines of code (in thousands) and a_b, b_b, c_b, d_b have their usual meanings. The basic COCOMO equations are of the form

(A) $E = a_b (\text{KLOC}) \exp(b_b), D = c_b (E) \exp(d_b)$

(B) $D = a_b (\text{KLOC}) \exp(b_b), E = c_b (D) \exp(d_b)$

(C) $E = a_b \exp(b_b), D = c_b (\text{KLOC}) \exp(d_b)$

(D) $E = a_b \exp(D_b), D = c_b (\text{KLOC}) \exp(b_b)$

Answer: (A)

Exp: Basic cocomo model takes the form

Effort applied (E) = $a_b (\text{kLoc})^{b_b}$

Development time(D) $c_b (E) d_b$

6. Consider the following two statements.

S_1 : if a candidate is known to be corrupt, then he will not be elected

S_2 : if a candidate is kind, he will be elected

Which one of the following statements follows from S_1 and S_2 per sound interference rules of logic?

- (A) If a person is known to corrupt, he is kind
- (B) If a person is not known to be corrupt, he is not kind
- (C) If a person is kind, he is not known to be corrupt
- (D) If a person is not kind, he is not known to be corrupt

Answer: (C)

Exp: Let P : candidate known to be corrupt

q : candidate will be elected

r : candidate is kind

then $S_1 = p \rightarrow \sim q$
 $= q \rightarrow \sim p$ (contrapositive rule)
 and $s_2 : r \rightarrow q \Rightarrow r \rightarrow \sim p$ (transitive rule)
 i.e., If a person is kind, he is not known to be corrupt
 \therefore Option is C

7. Assume that for a certain processor, a read request takes 50 nanoseconds on a cache miss and 5 nanoseconds on a cache hit. Suppose while running a program, it was observed that 80% of the processors read requests result in a cache hit. The average and access time in nanoseconds is _____.

Answer: (14)

Exp: Average read access time = $[(0.8)(5) + (0.2)(50)]$ ns.
 $= 4 + 10 = 14$ ns

8. A system has 6 identical resources and N processes competing for them. Each process can request atmost 2 resources. Which one of the following values of N could lead to a deadlock?
 (A) 1 (B) 2 (C) 3 (D) 4

Answer: No option

Exp: It might be "WRONG" question.

$N = 2 \Rightarrow$

P_1	P_2	No. of resources = 6
2	2	
1	1	

Each process can request atmost 2

$N = 3 \Rightarrow$

P_1	P_2	P_3
2	2	2

$N = 4 \Rightarrow$

P_1	P_2	P_3	P_4
1	1	1	1
1	1		

Therefore, no option leads to dead lock.

9. Consider a complete binary tree where the left and the right subtrees of the root are max-heaps. The lower bound for the number of operations to convert the tree to a heap is
 (A) $\Omega(\log n)$ (B) $\Omega(n)$ (C) $\Omega(n \log n)$ (D) $\Omega(n^2)$

10. In the context of abstract-syntax-tree (AST) and control-flow-graph (CFG), which one of the following is TRUE?
 (A) In both AST and CFG, let node, N_2 be the successor of node N_1 . In the input program, the code corresponding to N_2 is present after the code corresponding in N_1 .

- (B) For any input program, neither AST nor CFG will contain a cycle
- (C) The maximum number of successors of a node in an AST and a CFG depends on the input program
- (D) Each node in AST and CFG corresponds to at most one statement in the input program

Answer: (C)

Exp: Optional (A) is not true when CFG contains cycle

Option (B) is false as CFG can contain cycle

Option (D) is false as a single node can contain block of statements.

11. With reference to the B+ tree index of order 1 shown below, the minimum number of nodes (including the Root node) that must be fetched in order to satisfy the following query: “Get all records with a search key greater than or equal to 7 and less than 15” is _____

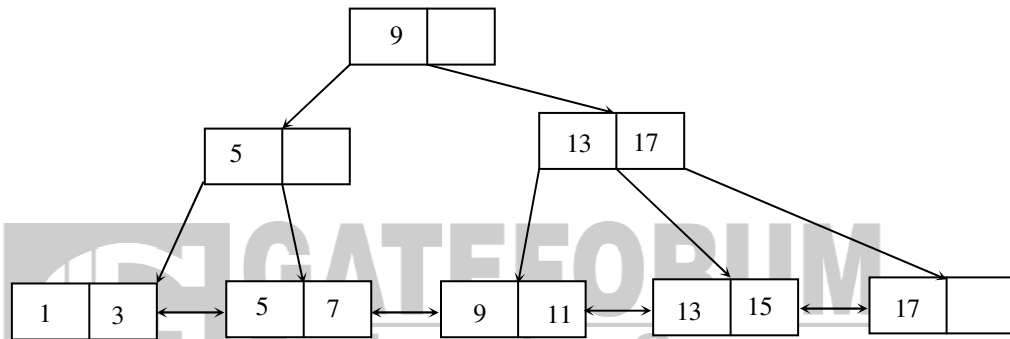

Answer: (6)

Exp:

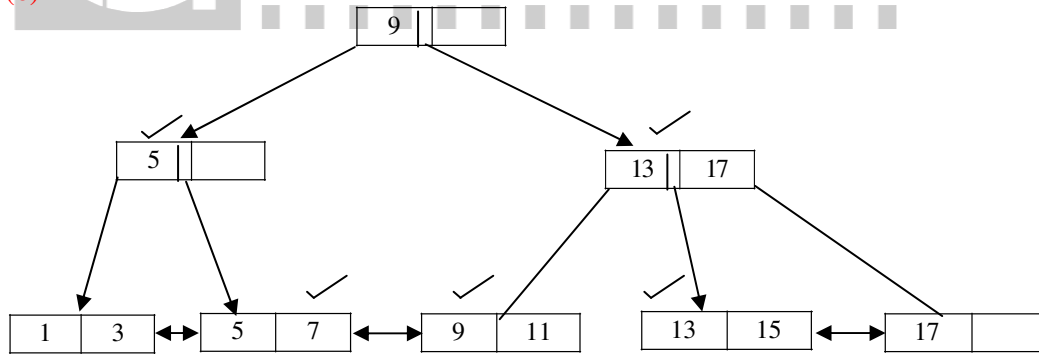

12. A software requirements specification (SRS) document should avoid discussing which one of the following?

- (A) User interface issues
- (B) Non-functional requirements
- (C) Design specification
- (D) Interfaces with third party software

Answer: (D)

Exp: SRS is a description of a software system to be developed, laying out functional & non-functional requirements and may include a set of use cases that describe interactions the user will have with the software.

13. Identify the correct order in which a server process must invoke the function calls accept, bind, listen, and recv according to UNIX socket APL
- (A) listen, accept, bind recv (B) bind, listen, accept, recv
(C) bind, accept, listen, recv (D) accept, listen, bind recv

Answer: (B)

Exp: The correct order in which a server process must invoke the function calls is bind, listen, accept and recv. First three are used in connection establishment phase and recv is used in data transfer phase.

14. The larger of the two eigenvalues of the matrix $\begin{bmatrix} 4 & 5 \\ 2 & 1 \end{bmatrix}$ is _____

Answer: (6)

Exp: Characteristic equation is $\begin{vmatrix} 4-\lambda & 5 \\ 2 & 1-\lambda \end{vmatrix} = 0$

$$\Rightarrow \lambda^2 - 5\lambda - 6 = 0 \Rightarrow (\lambda - 6)(\lambda + 1) = 0 \Rightarrow \lambda = 6, -1$$

∴ Larger eigen value is 6

15. The cardinality of the power set of $\{0, 1, 2, \dots, 10\}$ is _____

Answer: (2048)

Exp: cardinality of the power set of $\{0, 1, 2, \dots, 10\}$ is 2^{11} i.e., 2048

16. Which one of the following statements is NOT correct about HTTP cookies?
- (A) A cookie is a piece of code that has the potential to compromise the security of an internet user
(B) A cookie gains entry to the user's work area through an HTTP header
(C) A cookie has an expiry date and time
(D) Cookies can be used to track the browsing pattern of a user at a particular site

Answer: (B)

- Exp:** (A) is correct
(B) Option B is false
(C) Option C is correct
(D) Option D is correct

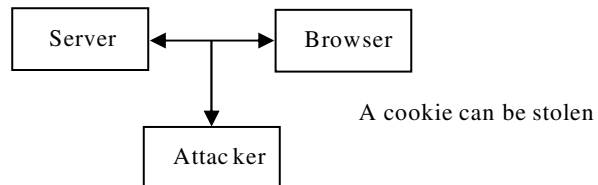

17. Consider the following function written the C programming language.

```
void foo(char *a) {
    if( *a && *a != ' '){
        putchar (*a);
    }
}
```

The output of the above function on input “ABCD EFGH” is

- (A) ABCD EFGH
- (B) ABCD
- (C) HGFE DCBA
- (D) DCBA

Answer: (D)

Exp:

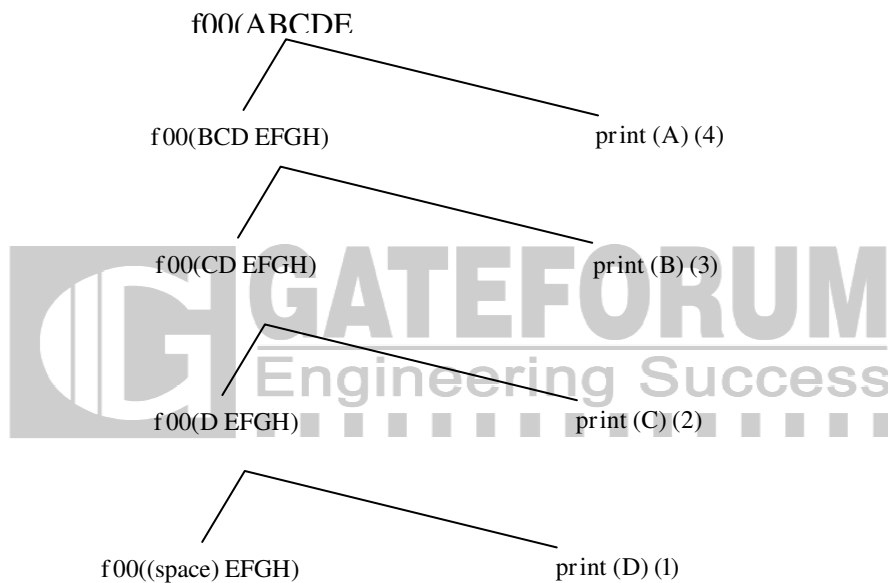

if condition fails
& returns controls
∴ DCBA will be pointed

18. A link has a transmission speed of 10^6 bits/sec. It uses data packets of size 1000 bytes each. Assume that the acknowledgement has negligible transmission delay, and that its propagation delay is the same as the data propagation delay. Also assume that the processing delays at the nodes are negligible. The efficiency of the stop-and-wait protocol in this setup is exactly 25%. The value of the one-way propagation delay (in milliseconds) is _____.

Answer: (12)

Exp: Given, $B = 10^6$ bps
 $L = 1000$ bytes
 $\eta = 25\%$
 $T_p = ?$

In stop-and-wait, $\eta = \frac{1}{1+2a}$

$\Rightarrow \frac{1}{4} = \frac{1}{1+2a} \Rightarrow 1+2a = 4$

$2a = 3; \quad a = \frac{3}{2}$

$T_x = \frac{L}{B} = \frac{8 \times 10^3}{10^6} = 8\text{ms}$

$\frac{T_p}{T_x} = \frac{3}{2}; \quad 2T_p = 3T_x$

$2T_p = 24\text{ms}$

$T_p = 12\text{ms}$

19. The minimum number of JK flip-flops required to construct a synchronous counter with the count sequence (0,0, 1, 1, 2, 2, 3, 3, 0, 0,.....) is _____.

Answer: (2)

Exp: Here number of distinct states are 4. So, minimum number of flip-flop required is = 2.

20. Match the following:

(P) Lexical analysis	(1) Graph coloring
(Q) Parsing	(2) DFA minimization
(R) Register allocation	(3) Post-order traversal
(S) Expression evaluation	(4) Production tree

(A) P-2, Q-3, R-1, S-4

(B) P-2, Q-1, R-4, S-3

(C) P-2, Q-4, R-1, S-3

(D) P-2, Q-3, R-4, S-1

Answer: (C)

Exp: Lemical Analyzer uses DFA to recognize the longest possible input sequence that makes up a token. Parser takes input in the form of tokens and usually builds a data structure in the form of parse tree. Here parse tree can be termed as a Production tree as parser uses production of the grammar to check whether generated tokens form a meaningful compression).

Register allocation can be reduced to K-colouring problem where K is the number of registers available on the target architecture.

Post order traversal of expression tree gives postfix notation for a given expression & this post fix notation can be evaluated using stack.

21. Consider two decision problems Q_1, Q_2 such that Q_1 reduces in polynomial time to 3-SAT and 3-SAT reduces in polynomial time to Q_2 . Then which one of following is consistent with the above statement?

- (A) Q_1 is in NP, Q_2 in NP hard (B) Q_2 is in NP, Q_1 is NP hard
 (C) Both Q_1 and Q_2 are in NP (D) Both Q_1 and Q_2 are NP hard

Answer: (A)

Exp: 3-SAT \Rightarrow NPC problem

$$Q_1 \leq p \quad 3-SAT \leq p \quad Q_2 \leq p \quad \leq p$$

$$\text{hence} \rightarrow Q_1 \text{ is in NP} \leq p$$

but Q_2 is not given in NP

Hence Q_2 is in NP-Hard.

22. A computer system implements a 40-bit virtual address, page size of 8 kilobytes, and a 128-entry translation look-aside buffer (TLB) organized into 32 sets each having four ways. Assume that the TLB tag does not store any process id. The minimum length of the TLB tag in bits is _____.

Answer: (22)

Exp: 22 bits

22	5	13
TAG	SET	WORD
	OFFSET	OFFSET

23. Consider the following C function.

```
int fun(int n) {
    int x = 1, k;
    if (n == 1) return x;
    for (k = 1; k < n; ++k)
        x = x + fun(k) * fun(n - k);
    return x;
}
```

The return value of fun (5) is _____

Answer: (51)

Exp: Recurrence Relation is

$$f(n)=1, \text{ if } n=1$$

$$f(n)=1 + \sum_{k=1}^{n-1} f(k).f(n-k) \text{ if } n > 1$$

n	1	2	3	4	5	6
f(n)	1	2	5	15	51	188

24. Consider the following statements
- I. The complement of every Turing decidable language is Turing decidable
 - II. There exists some language which is in NP but is not Turing decidable
 - III. If L is a language in NP, L is Turing decidable
- Which of the above statements is/are true?
- (A) Only II (B) Only III (C) Only I and II (D) Only I and III

Answer: (D)

Exp: Turing decidable \Rightarrow Recursive language

Turing recognizable \Rightarrow Recursive enumerable language

I) Complement of Turing decidable language is decidable which is true.

III) True (Theorem)

Which violates (II) hence key is D

25. The number of divisors of 2100 is _____.

Answer: (36)

Exp: Let $N = 2100$

$$= 2^2 \times 3 \times 5^2 \times 7 \text{ (i.e., product of primes)}$$

Then the number of divisors of 2100 is

$$(2+1) \cdot (1+1) \cdot (2+1) \cdot (1+1) \text{ i.e., } (3)(2)(3)(2) \text{ i.e., } 36$$

Q.No-26-55 Carry Two Marks Each

26. In a connected graph, a bridge is an edge whose removal disconnects a graph. Which one of the following statements is true?
- (A) A tree has no bridges
 - (B) A bridge cannot be part of a simple cycle
 - (C) Every edge of a clique with size ≥ 3 is a bridge (A clique is any complete sub graph of a graph)
 - (D) A graph with bridges cannot have a cycle

Answer: (B)

Exp: Since, every edge in a tree is bridge

\therefore (A) is false

Since, every edge in a complete graph K_n ($n \geq 3$) is not a bridge \Rightarrow (C) is false

Let us consider the following graph G:

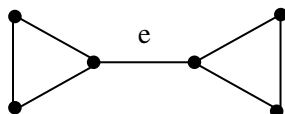

This graph has a bridge i.e., edge 'e' and a cycle of length '3'

∴ (D) is false

Since, in a cycle every edge is not a bridge

∴ (B) is true

27. Consider six memory partitions of sizes 200 KB, 400 KB, 600 KB, 500 KB, 300 KB and 250 KB, where KB refers to kilobyte. These partitions need to be allotted to four processes of sizes 357 KB, 210KB, 468 KB and 491 KB in that order. If the best fit algorithm is used, which partitions are NOT allotted to any process?

(A) 200KB and 300 KB

(B) 200KB and 250 KB

(C) 250KB and 300 KB

(D) 300KB and 400 KB

Answer: (A)

Exp:

200 kB	400kB	600kB	500kB	300kB	250kB
	357 kB	491kB	468kB		201kB

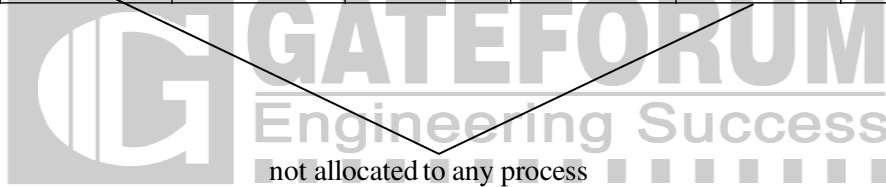

28. Which one of the following assertions concerning code inspection and code walkthrough is true?

(A) Code inspection is carried out once the code has been unit tested

(B) Code inspection and code walkthrough are synonyms

(C) Adherence to coding standards is checked during code inspection

(D) Code walkthrough is usually carried out by an independent test team

Answer: (A)

29. Given below are some algorithms, and some algorithm design paradigms.

(1) Dijkstra's Shortest Path	(i) Divide and Conquer
(2) Floyd-Warshall algorithm to compute all pair shortest path	(ii) Dynamic Programming
(3) Binary search on a sorted array	(iii) Greedy design
(4) Backtracking search on a graph	(iv) Depth-first search
	(v) Breadth-first search

Match the above algorithms on the left to the corresponding design paradigm they follow.

- (A) 1-i, 2-iii, 3-i, 4-v (B) 1-iii, 2-iii, 3-i, 4-v
(C) 1-iii, 2-ii, 3-i, 4-iv (D) 1-iii, 2-ii, 3-i, 4-v

Answer: (C)

Exp: Dijkstra shortest path algorithm find next node by choosing minimum distance hence greedy approach.

Floyd warshall always apply dynamic programming, once it saves a cost and in the next iteration it will change if this is minimum hence dynamic.

⇒ Binary search always divide on two parts .Hence divide and conquer.

⇒ Backtracking uses by DFS, one it will reach to dead end it will take back track.

30. Suppose you are provided with the following function declaration in the C programming language

```
int partition (int a [ ], int n);
```

The function treats the first element of a [] as a pivot, and rearranges the array so that all elements less than or equal to the pivot is in the left part of the array , and all elements greater than the pivot is in the right part. In addition, it moves the pivot so that the pivot is the last elements of the left part. The return value is the number of elements in the left part.

The following partially given function in the C programming language is used to find the K^{th} smallest element in an array a [] of size n using the partition function We assume $k \leq n$.

```
int kth_smallest (int a [ ], int n, int k)
{
    int left_end = partition (a,n);
    if (left_end + 1 == k) {
        return a[left_end];
    }
    if (left_end + 1 > k) {
        return kth_smallest ( _____ );
    } else {
        return kth_smallest ( _____ );
    }
}
```

The missing argument lists are respectively

- (A) (a, left_end, k) and (a + left_end + 1, n - left_end - 1, k - left_end - 1)
(B) (a, left_end, k) and (a, n - left_end - 1, k - left_end - 1)
(C) (a + left_end + 1, n - left_end - 1, k - left_end - 1) and (a, left_end, k)
(D) (a, n - left_end - 1, k - left_end - 1) and (a, left_end, k)

Answer: (A)

31. Consider a typical disk that rotates at 15000 rotations per minute (RPM) and has a transfer rate of 50×10^6 bytes/sec. if the average seek time of the disk is twice the average rotational delay and the controller's transfer time is 10 times the disk transfer time, the average time (in milliseconds) to read or write a 512-byte sector of the disk is _____.

Answer: (6.1)

Exp: 60sec \rightarrow 15000 rotations

$$\frac{60}{15000} = 4\text{ms} \leftarrow 1 \text{ rotation}$$

$$\therefore \text{Average rotational delay} = \frac{1}{2} \times 4 = 2\text{ms}$$

$$\Rightarrow \text{As per question, average seek time} = 2 \times \text{Avg. rotational delay} \\ = 2 \times 2 = 4\text{ms}$$

$$\left. \begin{array}{l} 1\text{sec} \rightarrow 50 \times 10^6 \text{ bytes} \\ 0.01\text{ms} = \frac{512}{50 \times 10^6} \leftarrow 512 \text{ bytes} \end{array} \right\} \text{disk transfer time.}$$

$$\Rightarrow \text{As per Question, controller's transfer time is} = 10 \times 0.01 \text{ ms} = 0.1 \text{ ms}$$

$$\therefore \text{Avg. Time} = 4\text{ms} + 0.1 \text{ ms} + 2 \text{ ms} = 6.1 \text{ ms}$$

32. Let $f(x) = x^{-1/3}$ and A denote the area of the region bounded by $f(x)$ and the X-axis, when x varies from -1 to 1 . Which of the following statements is/are TRUE?

(I) f is continuous in $[-1,1]$

(II) f is not bounded in $[-1,1]$

(III) A is nonzero and finite

(A) II only

(B) III only

(C) II and III only

(D) I, II and III

Answer: (A)

Exp: Since $f(0) \rightarrow \infty$

$\therefore f$ is not bounded in $[-1,1]$ and hence f is not continuous in $[-1,1]$

$$A = \int_{-1}^1 f(x) dx = \int_{-1}^0 x^{-1/3} dx + \int_0^1 x^{-1/3} dx \\ = \frac{2}{3} \left(x^{2/3} \right)_{-1}^0 + \frac{2}{3} \left(x^{2/3} \right)_0^1 = 0$$

\therefore Statement II only true

33. Consider the intermediate code given below.

- (1) $i = 1$
- (2) $j = 1$
- (3) $t1 = 5 * i$
- (4) $t2 = t1 + j$
- (5) $t3 = 4 * t2$
- (6) $t4 = t3$
- (7) $a[t4] = -1$
- (8) $j = j + 1$
- (9) if $j \leq 5$ goto (3)
- (10) $i = i + 1$
- (11) if $i < 5$ goto (2)

The number of nodes and edges in the control-flow-graph constructed for the above code, respectively, are

- (A) 5 and 7 (B) 6 and 7 (C) 5 and 5 (D) 7 and 8

Answer: (B)

34. The number of min-terms after minimizing the following Boolean expression is _____.

$$[D' + AB' + A'C + AC'D + A'C'D]'$$

Answer: (1)

Exp: Given function is

$$F(A, B, C, D) = [D' + AB' + A'C + AC'D + A'C'D]'$$

According to the function k-map is

		CD			
		00	01	11	10
AB	00	0	0	0	0
	01	0	0	0	0
	11	0	0	1	0
	10	0	0	0	0

Number of min terms = 1.

35. The number of onto function (surjective function) from set $X = \{1, 2, 3, 4\}$ to set $Y = \{a, b, c\}$ is _____.

Answer: (36)

Exp: Number of onto function from set X to set Y with $|x| = m, |y| = n$ is $\sum_{k=0}^{n-1} (-1)^k \cdot n_{c_k} \cdot (n-k)^m$

$m = 4, n = 3 \Rightarrow$ number of onto fns is

$$\begin{aligned} \sum_{k=0}^2 (-1)^k \cdot 3_{c_k} \cdot (3-k)^4 &= 3^4 - (3)(2)^4 + (3)(1)^4 \\ &= 81 - 48 + 3 = 36 \end{aligned}$$

36. Consider the alphabet $\Sigma = \{0, 1\}$, the null/empty string λ and the sets of strings $X_0, X_1,$ and X_2 generated by the corresponding non-terminals of regular grammar. $X_0, X_1,$ and X_2 are related as follows:

$$X_0 = 1X_1$$

$$X_1 = 0X_1 + 1X_2$$

$$X_2 = 0X_1 + \{\lambda\}$$

Which one of the following choices precisely represents the strings in X_0 ?

(A) $10(0^* + (10)^*)^*1$

(B) $10(0^* + (10)^*)^*1$

(C) $1(0+10)^*1$

(D) $10(0+10)^*1 + 110(0+10)^*1$

Answer: (C)

37. Which of the following languages is/are regular?

$$L_1 : \{wxw^R \mid w, x \in \{a, b\}^* \text{ and } |w|, |x| > 0\}, w^R \text{ is the reverse of string } w$$

$$L_2 : \{a^n b^m \mid m \neq n \text{ and } m, n \geq 0\}$$

$$L_3 : \{a^p b^q c^r \mid p, q, r \geq 0\}$$

(A) L_1 and L_3 only

(B) L_1 only

(C) L_2 and L_3 only

(D) L_3 only

Answer: (A)

Exp: $L_1 = \{wxw^R \mid w, x \in \{a, b\}^* \text{ and } |w|, |x| > 0\}$

w^R is reverse of string w .

It is regular

Regular expression

$$a(a+b)^* a + b(a+b)^* b$$

$$L_2 = \{a^n b^m \mid m \neq n, m, n \geq 0\}$$

Hence $m \neq n$, that mean n is greater than m , or m is greater than n .

So we need memory, so we can't draw DfA for it.

$$L_3 = \{a^p b^q c^r \mid p, q, r \geq 0\}$$

a, b, c

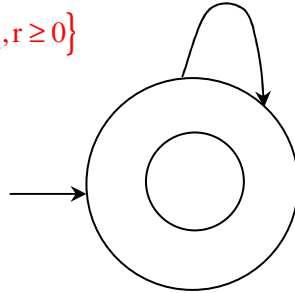

Hence Answer: A

38. Consider a processor with byte-addressable memory. Assume that all registers, including Program Counter (PC) and Program Status Word (PSW), are of size 2 bytes. A stack in the main memory is implemented from memory location $(0100)_{16}$ and it grows upward. The stack pointer (SP) points to the top element of the stack. The current value of SP is $(016E)_{16}$. The CALL instruction is of two words, the first word is the op-code and the second word is the starting address of the subroutine. (one word = 2bytes). The CALL instruction is implemented as follows:

- Store the current Vale of PC in the Stack
- Store the value of PSW register in the stack
- Load the starting address of the subroutine in PC

The content of PC just before the fetch of a CALL instruction is $(5FA0)_{16}$. After execution of the CALL instruction, the value of the stack pointer is

- (A) $(016A)_{16}$ (B) $(016C)_{16}$ (C) $(0170)_{16}$ (D) $(0172)_{16}$

Answer: (D)

39. The number of states in the minimal deterministic finite automaton corresponding to the regular expression $(0+1)^*(10)$ is _____

Answer: (3)

Exp: $(0+1)^*10$

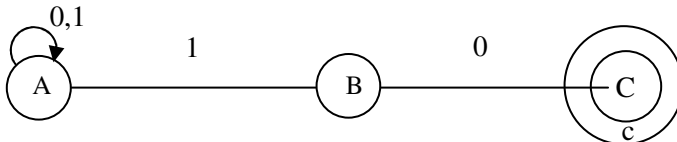

	0	1
A	A	AB
B	C	-
C	-	-
AB	AC	AB
AC	A	AB

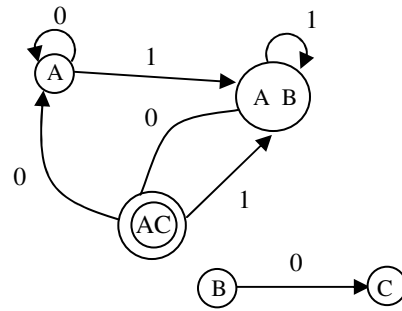

Total minimum DFA states = 3.

40. Host A sends a UDP datagram containing 8880 bytes of user data to host B over an Ethernet LAN. Ethernet frames may carry data up to 1500 bytes (i.e. MTU = 1500 bytes). Size of UDP header is 8 bytes and size of IP header is 20 bytes. There is no option field in IP header. How many total number of IP fragments will be transmitted and what will be the contents of offset field in the last fragment?

- (A) 6 and 95 (B) 6 and 7400 (C) 7 and 1110 (D) 7 and 8880

Answer: (C)

Exp:

8880 Bytes MTU
1500 B

	(1)	(2)	(3)	(4)	(5)	(6)	(7)
DL	0-1471	1472-2951	2952-4431	4432-5911	5912-7391	7392-8871	8872-8879
HL	28	20	20	20	20	20	20
OFFSET							$\frac{8872}{8} = 1109$

41. Consider the following routing table at an IP router:

Network No.	Net Mask	Next Hop
128.96.170.0	255.255.254.0	Interface 0
128.96.168.0	255.255.254.0	Interface 1
128.96.166.0	255.255.254.0	R2
128.96.164.0	255.255.252.0	R3
0.0.0.0	Default	R4

For each IP address in Group I identify the correct choice of the next hop from Group II using the entries from the routing table above.

Group I	Group II
(i) 128.96.171.92	(a) Interface 0
(ii) 128.96.167.151	(b) Interface 1
(iii) 128.96.163..151	(c) R2
(iv) 128.96.165.121	(d) R3
	(e) R4

(A) i – a, ii – c, iii – e, iv – d

(B) i – a, ii – d, iii – b, iv – e

(D) i – b, ii – c, iii – d, iv – e

(D) i – b, ii – c, iii – e, iv – d

Answer: (A)

Exp: Given, 1st IP:128. 96. 171. 92

$$\begin{array}{r} 1^{\text{st}} \text{ MASK : } 255. 255. 254. 0 \\ \hline 128. 96. 170. 0 \end{array}$$

Which is matching with first entry in n/w no. so the corresponding next loop is interface 0.

So (i) → (a)

Given

$$\begin{array}{r} 2^{\text{nd}} \text{ IP : } 128. 96. 167. 151 \\ 1^{\text{st}} \text{ MASK : } 255. 255. 254. 0 \\ \hline 128. 96. 166. 0 \end{array}$$

Which is matching with 3rd entry of the n/w no. column. So the corresponding next lap is R₂.

So (ii) → (c)

Given

$$\begin{array}{r} 3^{\text{rd}} \text{ IP : } 128. 96. 163. 151 \\ 1^{\text{st}} \text{ MASK : } 255. 255. 254. 0 \\ \hline 128. 96. 162. 0 \end{array}$$

Which is not matching

Given

$$\begin{array}{r} 3^{\text{rd}} \text{ IP : } 128. 96. 163. 151 \\ 1^{\text{st}} \text{ MASK : } 255. 255. 252. 0 \\ \hline 128. 96. 170. 0 \end{array}$$

The corresponding 4th entry of n/w no. column is not matching. So it gives R4.

So (iii) → (e)

Given

$$\begin{array}{r} 4^{\text{th}} \text{ IP : } 128. 96. 165. 121 \\ 1^{\text{st}} \text{ MASK : } 255. 255. 254. 0 \\ \hline 128. 96. 164. 0 \end{array}$$

It is not matching with the first 3 entries of n/w no column. If we apply the 2nd mask then the result is 128.96.164.0. since it is matching with 4th entry of n/w no column,

⇒ (iv) → (d) .

So, overall (i) – a, (ii) – (c), (iii) – (e), (iv) – (d).

42. Consider two relations $R_1(A,B)$ with the tuples (1,5), (3,7) and $R_2(A,C) = (1,7), (4,9)$. Assume that $R(A,B,C)$ is the full natural outer join of R_1 and R_2 . Consider the following tuples of the form (A,B,C): a = (1.5,null), b = (1,null,7) c = (3,null,9), d = (4,7,null), e = (1,5,7), f = (3,7,null), g = (4,null,9). Which one of the following statements is correct?
- (A) R contains a,b,e,f,g but not c, d. (B) R contains all of a,b,c,d,e,f,g
(C) R contains e,f,g but not a,b (D) R contains e but not f,g.

Answer: (C)

Exp:

R_1	A	B
	1	5
	3	7

R_2	A	C
	1	7
	4	9

A	B	C
1	5	7
3	7	null
4	null	9

$R_1 \bowtie R_2$

43. Consider a simple checkpointing protocol and the following set of operations in the log.
(Start, T4); (write, T4, y, 2, 3); (Start, T1); (commit, T4); (write, T1, z, 5, 7);
(checkpoint);
(Start, T2); (write, T2, x, 1, 9); (commit, T2); (start, T3); (write, T3, z, 7, 2);
If a crash happens now and the system tries to recover using both undo and redo operations, what are the contents of the undo lists and the redo list?
- (A) Undo T3, T1; Redo T2 (B) Undo T3, T1; Redo T2, T4
(C) Undo: none; redo : T2, T4, T3, T1 (D) Undo T3, T1; T4; Redo : T2

Answer: (A)

Exp: As T_1 & T_3 are not yet committed they must be undone. The transactions which are after the latest checkpoint must be redone. So T_2 must be redone. No need to redo the records which are before last checkpoint, so T_4 need not be redone.

44. A computer system implements 8 kilobyte pages and a +32-bit physical address space. Each page table entry contains a valid bit, a dirty bit, three permission bits, and the translation. If the maximum size of the page table of a process is 24 megabytes, the length of the virtual address supported by the system is _____ bits.

Answer: (36)

Exp: Given Page size = 8kb

PAS = 32 – bit

$$\therefore \text{No. of frames} = \frac{\text{PAS}}{\text{P.S}} = \frac{2^{32}}{2^{13}} = 2^{19} \text{ frames.}$$

So, it is given that each page table entry contains a valid bit, a dirty bit, 3 permission bits. \Rightarrow 5 bits are reserved.

\therefore It means one entry requires $19 + 5 = 24$ bits

\therefore Page Table size = $n \times e$

$$24 \times 2^{20} \times 3 = n \times (24)$$

$$\Rightarrow n = \frac{24 \times 2^{20} \times 8}{24} = 2^{23} \text{ pages}$$

Length of the virtual address = $23+13=36$ bits

45. Which one of the following hash functions on integers will distribute keys most uniformly over 10 buckets numbered 0 to 9 for i ranging from 0 to 2020?
- (A) $h(i) = i^2 \text{ mod } 10$ (B) $h(i) = i^3 \text{ mod } 10$
 (C) $h(i) = (11*i^2) \text{ mod } 10$ (D) $h(i) = (12*i) \text{ mod } 10$

Answer: (B)

Exp: If we take first 10 elements, number of collisions taken by the hash function given by option (B) is less when compared to others.

46. Assume that the bandwidth for a TCP connection is 1048560 bits/sec. Let α be the value of RTT in milliseconds. (rounded off to the nearest integer) after which the TCP window scale option is needed. Let β be the maximum possible window size the window scale option. Then the values of α and β are
- (A) 63 milliseconds, 65535×2^{14} (B) 63 milliseconds, 65535×2^{16}
 (C) 500 milliseconds, 65535×2^{14} (D) 500 milliseconds, 65535×2^{16}

47. A young tableau is a 2D array of integers increasing from left to right and from top to bottom. Any unfilled entries are marked with ∞ , and hence there cannot be any entry to the right of, or below a ∞ . The following Young tableau consists of unique entries.

1	2	5	14
3	4	6	23
10	12	18	25
31	∞	∞	∞

When an element is removed from a Young tableau, other elements should be moved into its place so that the resulting table is still a Young tableau (unfilled entries may be filled in with a ∞). The minimum number of entries (other than 1) to be shifted, to remove 1 from the given Young tableau is _____

Answer: (5)

Exp:

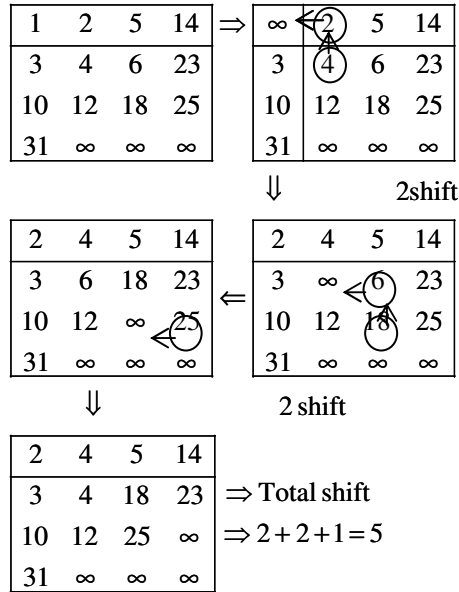

48. A half adder is implemented with XOR and AND gates. A full adder is implemented with two half adders and one OR gate. The propagation delay of an XOR gate is twice that of an AND/OR gate. The propagation delay of an AND/OR gate is 1.2 microseconds. A 4-bit ripple-carry binary adder is implemented by using four full adders. The total propagation time of this 4-bit binary adder in microseconds is _____.

Answer: (19.2)

Exp:

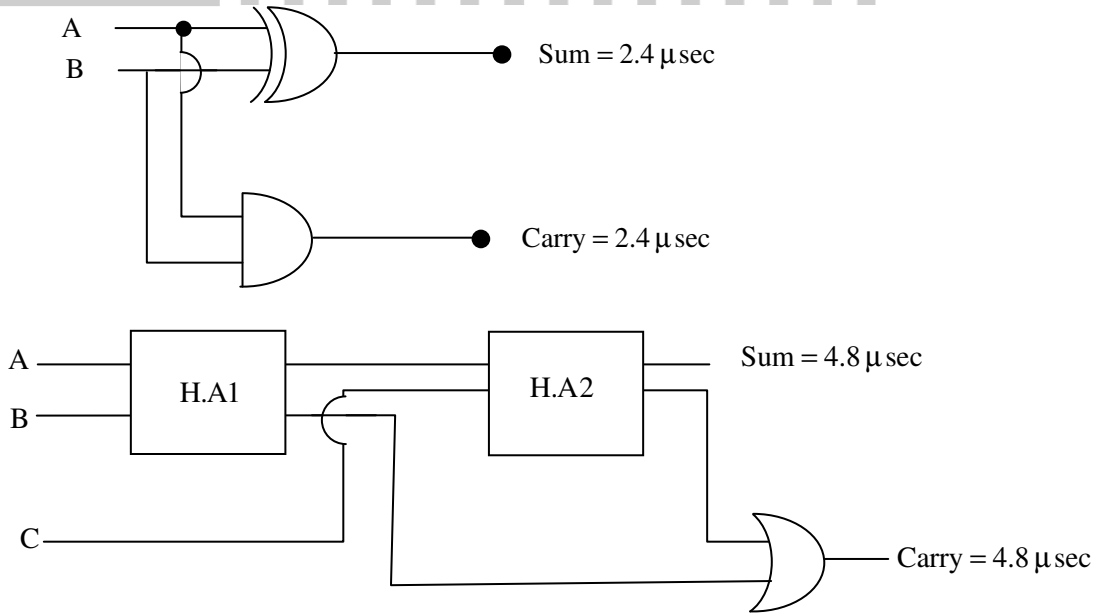

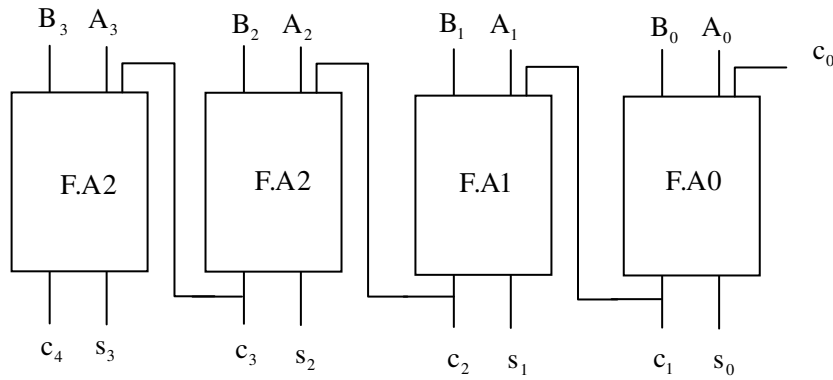

Here sum and carry delay is same = 4.8 μ sec

$$\begin{aligned} \text{So, } T_{\text{total}} &= (4 \times 4.8) \mu\text{sec} \\ &= 19.2 \mu\text{sec} \end{aligned}$$

49. Consider the sequence of machine instruction given below:

MUL R5,R0,R1

DIV R6,R2,R3

ADD R7,R5,R6

SUB R8,R7,R4

In the above sequence, R0 to R8 are general purpose registers. In the instructions shown, the first register stores the result of the operation performed on the second and the third registers. This sequence of instructions is to be executed in a pipelined instruction processor with the following 4 stages (1) Instruction Fetch and Decode (IF), (2) Operand Fetch (OF), (3) Perform Operation (PO) and (4) Write back the result (WB). The IF, OF and WB stages take 1 clock cycle each for any instruction. The PO stage takes 1 clock cycle for ADD or SUB instruction, 3 clock cycles for MUL instruction and 5 clock cycles for DIV instruction. The pipelined processor uses operand forwarding from the PO stage to the OF stage. The number of clock cycles taken for the execution of the above sequence of instructions is _____

Answer: (13)

Exp: I \Rightarrow Instruction Fetch and Decode

O \Rightarrow Operand Fetch

P \Rightarrow Perform operation

W \Rightarrow write back the result

	1	2	3	4	5	6	7	8	9	10	11	12	13
I	O	P	P	P	W								
	I	O	-	-	P	P	P	P	P	W			
		I	-	-	O	-	-	-	-	P	W		
			I	-	-	O	-	-	-	-	P	W	

50 Perform the following operations on the matrix $\begin{bmatrix} 3 & 4 & 45 \\ 7 & 9 & 105 \\ 13 & 2 & 195 \end{bmatrix}$.

(i) Add the third row to the second row

(ii) Subtract the third column from the first column.

The determinant of the resultant matrix is _____.

Answer: (0)

Exp: Let $A = \begin{bmatrix} 3 & 4 & 45 \\ 7 & 9 & 105 \\ 13 & 2 & 195 \end{bmatrix}$

$$R_2 \rightarrow R_2 + R_3$$

$$\sim \begin{bmatrix} 3 & 4 & 45 \\ 20 & 11 & 300 \\ 13 & 2 & 195 \end{bmatrix}$$

$$C_1 \rightarrow C_2 - C_3$$

$$\sim \begin{bmatrix} -42 & 4 & 45 \\ -280 & 11 & 300 \\ -182 & 2 & 195 \end{bmatrix} = B \text{ (resultant matrix)}$$

$$\text{Now } |B| = \begin{vmatrix} -42 & 4 & 3 \\ 280 & 11 & 300 \\ -182 & 2 & 195 \end{vmatrix}$$

$$= (-14)(15) \begin{vmatrix} 3 & 4 & 3 \\ 20 & 11 & 20 \\ 13 & 2 & 13 \end{vmatrix}$$

$$= 0$$

Method 2: Determinant is unaltered by the operations (i) and (ii)

\therefore Determinant of the resultant matrix = Determinant of the given matrix

$$= \begin{vmatrix} 3 & 4 & 45 \\ 7 & 9 & 105 \\ 13 & 2 & 195 \end{vmatrix}$$

$$= 0 \text{ (Since } C_1, C_3 \text{ are proportional i.e., } C_3 = 15C_1)$$

51. Which one of the following well formed formulae is tautology?

(A) $\forall x \exists y R(x, y) \leftrightarrow \exists y \forall x R(x, y)$

(B) $(\forall x [\exists y R(x, y) \rightarrow S(x, y)]) \rightarrow \forall x \exists y S(x, y)$

(C) $[(\forall x \exists y (P(x, y) \rightarrow R(x, y)))] \rightarrow [\forall x \exists y (\neg P(x, y) \vee R(x, y))]$

(D) $\forall x \forall y p(x, y) \rightarrow \forall x \forall y p(y, x)$

Answer: (C)

Exp: Since $P \rightarrow R = \neg P \vee R$

$[\forall x \exists y (p(x, y) \rightarrow R(x, y))] \rightarrow [\forall x \exists y (\neg p(x, y) \vee R(x, y))]$ is a tautology.

52. A graph is self-complementary if it is isomorphic to its complement For all self-complementary graphs on n vertices, n is

(A) A multiple of 4

(B) Even

(C) Odd

(D) Congruent to 0 mod 4, or, 1 mod 4

Answer: (D)

Exp:

An n vertex self complementary graph has exactly half number of edges of the complete graph i.e., $\frac{n(n-1)}{4}$ edges. Since $n(n-1)$ must be divisible by 4, n must be congruent to 0 or 1 module 4.

53. The secant method is used to find the root of an equation $f(x) = 0$. It is started from two distinct estimates, x_a and x_b for the root. It is an iterative procedure involving linear interpolation to a root. The iteration stops if $f(x_b)$ is very small and then x_b is the solution. The procedure is given below. Observe that there is an expression which is missing and is marked by? Which is the suitable expression that is to be put in place of ? so that it follows all steps of the secant method?

Secant

Initialize: x_a, x_b, ϵ, N

// ϵ = convergence indicator

// N = maximum no. of iterations

$f_b = -f(x_b)$

$i = 0$

While ($i < N$ and $|f_b| > (\epsilon)$) do

$i = i + 1$

// update counter

$x_t = ?$

// missing expression for

$x_a = x_b$

// intermediate value

// reset x_a

$x_b = x_t$

// reset x_b

$f_b = f(x_b)$

// function value at new x_b

end while

if $|f_b| > \epsilon$ then

// loop is terminated with $i = N$

write “Non-convergence”

else

Write ‘Non-convergence’

Else

Write “return x_b ”

End if

(A) $x_b - (f_b - f(x_a)) f_b / (x_b - x_a)$

(B) $x_a - (f_b - f(x_a)) f_a / (x_b - x_a)$

(C) $x_b - (x_b - x_a) f_b / (f_b - f(x_a))$

(D) $x_a - (x_b - x_a) f_a / (f_b - f(x_a))$

Answer: (D)

Exp: Secant method direct formula

54. Let X and Y denote the sets containing 2 and 20 distinct objects respectively and F denote the set of all possible functions defined from X to Y. Let f be randomly chosen from F. The probability of f being one-to-one is _____.

Answer: (0.95)

Exp: $|X| = 2, |Y| = 20$

Number of functions from X to Y is 20^2 i.e., 400 and number of one-one functions from X to Y is $20P_2$ i.e., $20 \times 19 = 380$

\therefore Probability of a function f being one-one is $\frac{380}{400}$ i.e., 0.95

55. Consider the C program below.

```
#include <stdio.h>
```

```
int *A, stkTop;
```

```
int stkFunc (int opcode, int val)
```

```
{
```

```
    static int size = 0, stkTop = 0;
```

```
    switch (opcode) {
```

```
        case -1 : size = val; break;
```

```
        case 0 : if (stkTop < size) A [stkTop++] = val; break;
```

```
        default : if (stkTop) return A [--stkTop];
```

```
    }
```

```
    return -1;
```

```
}
```

```
int main ()
```

```
{  
int B[20] ; A = B; stkTop = -1;  
stkFunc (-1, 10);  
stkFunc (0, 5);  
stkFunc (0, 10);  
print f ("%d\n", stkFunc(1, 0) + stkfunc(1, 0));  
}
```

The value printed by the above program is _____.

Answer: (-2)

Exp: StkFunc(1,0) returns -1 both the times. So - 2 will be printed

