

2007

XE : Engineering Sciences

Duration : Three Hours

Maximum Marks :150

Read the following instructions carefully.

1. This question paper contains **seven** sections as listed below. Each section contains **28** objective questions. Q.1 to Q.6 carry **one** mark each and Q.7 to Q.28 carry **two** marks each.

Section	Page	Section	Page
A. Engineering Mathematics	02	E. Material Science	31
B. Computational Science	09	F. Solid Mechanics	36
C. Electrical Sciences	16	G. Thermodynamics	46
D. Fluid Mechanics	25		

2. Section A is compulsory. Choose **two** more sections from the remaining.
3. Using HB pencil, mark the sections you have chosen by darkening the appropriate bubbles on the left hand side of the **Objective Response Sheet (ORS)** provided. **Make sure you have correctly bubbled the sections you have chosen. ORS will not be evaluated if this information is NOT marked.**
4. Questions must be answered on **ORS** by darkening the appropriate bubble (marked A, B, C, D) using HB pencil against the question number on the left hand side of the ORS under the sections you have chosen. Each question has only one correct answer. In case you wish to change an answer, erase the old answer completely.
5. Wrong answers will carry **NEGATIVE** marks. In Q.1 to Q.6 of each section, **0.25** mark will be deducted for each wrong answer. In Q.7 to Q.25 and in Q.27 **0.5** mark will be deducted for each wrong answer. However, there is no negative marking in Q.26 and in Q.28. More than one answer bubbled against a question will be taken as an incorrect response. Unattempted questions will not carry any marks.
6. Write your registration number, your name and name of the examination centre at the specified locations on the right half of the **ORS**.
7. Using HB pencil, darken the appropriate bubble under each digit of your registration number and the letters corresponding to your paper code.
8. Calculator is allowed in the examination hall.
9. Charts, graph sheets or tables are **NOT** allowed in the examination hall.
10. Rough work can be done on the question paper itself. Additionally blank pages are given at the end of the question paper for rough work.
11. This question paper contains **56** printed pages including pages for rough work. Please check all pages and report, if there is any discrepancy.

A: Engineering Mathematics (Compulsory)

Q. 1 – Q. 6 carry one mark each.

Q.1

Let $M = \begin{pmatrix} 1 & 1 & 1 \\ 0 & 1 & 1 \\ 0 & 0 & 1 \end{pmatrix}$. Then the maximum number of linearly independent eigenvectors of M is

- (A) 0 (B) 1 (C) 2 (D) 3

Q.2

Let $L = \lim_{x \rightarrow \frac{\pi}{2}} \frac{\sin^2 2x}{\left(x - \frac{\pi}{2}\right)^2}$. Then L is equal to

- (A) -4 (B) 0 (C) 2 (D) 4

Q.3

Let $f(z) = \frac{1}{1-z^2}$. The coefficient of $\frac{1}{z-1}$ in the Laurent expansion of $f(z)$ about $z = 1$ is

- (A) -1 (B) -1/2 (C) 1/2 (D) 1

Q.4

Let $u(x, t)$ be the solution of the initial value problem

$$\frac{\partial^2 u}{\partial t^2} = 9 \frac{\partial^2 u}{\partial x^2}, \quad t > 0, \quad -\infty < x < \infty,$$

$$u(x, 0) = x + 5,$$

$$\frac{\partial u}{\partial t}(x, 0) = 0.$$

Then $u(2, 2)$ is

- (A) 7 (B) 13 (C) 14 (D) 26

Q.5

Two students take a test consisting of five *TRUE / FALSE* questions. To pass the test the students have to answer atleast three questions correctly. Both of them know the correct answers to two questions and guess the answers to the remaining three. The probability that only one student passes the test is equal to

- (A) $\frac{6}{32}$ (B) $\frac{7}{32}$ (C) $\frac{1}{4}$ (D) $\frac{3}{4}$

- Q.6 The equation $g(x) = x$ is solved by Newton-Raphson iteration method, starting with an initial approximation x_0 near the simple root α . If x_{n+1} is the approximation to α at the $(n+1)^{\text{th}}$ iteration, then

(A) $x_{n+1} = \frac{x_n g'(x_n) - g(x_n)}{1 - g'(x_n)}$

(B) $x_{n+1} = \frac{x_n g'(x_n) - g(x_n)}{g'(x_n) - 1}$

(C) $x_{n+1} = g(x_n)$

(D) $x_{n+1} = \frac{x_n g'(x_n) - g(x_n) + 2x_n}{g'(x_n) + 1}$

Q. 7 – Q. 24 carry two marks each.

- Q.7 Let $Ax = b$ be a system of m linear equations in n unknowns with $m < n$ and $b \neq 0$. Then the system has

- (A) $n - m$ solutions
(B) either zero or infinitely many solutions
(C) exactly one solution
(D) n solutions

- Q.8 Let R be an $n \times n$ nonsingular matrix. Let P and Q be two $n \times n$ matrices such that $Q = R^{-1}PR$. If x is an eigenvector of P corresponding to a nonzero eigenvalue λ of P , then

- (A) Rx is an eigenvector of Q corresponding to the eigenvalue λ of Q
(B) Rx is an eigenvector of Q corresponding to the eigenvalue $\frac{1}{\lambda}$ of Q
(C) $R^{-1}x$ is an eigenvector of Q corresponding to the eigenvalue $\frac{1}{\lambda}$ of Q
(D) $R^{-1}x$ is an eigenvector of Q corresponding to the eigenvalue λ of Q

- Q.9 Let M be a 2×2 matrix with eigenvalues 1 and 2. Then M^{-1} is

(A) $\frac{M - 3I}{2}$

(B) $\frac{3I + M}{2}$

(C) $\frac{3I - M}{2}$

(D) $\frac{-M - 3I}{2}$

- Q.10 The number of $n \times n$ matrices that are simultaneously Hermitian, unitary and diagonal is
- (A) 2^n (B) n^2 (C) $2n$ (D) 2
- Q.11 Let $M = \begin{pmatrix} 1 & b & a \\ 0 & 2 & c \\ 0 & 0 & 1 \end{pmatrix}$, where a, b, c are real numbers. Then M is diagonalizable
- (A) for all values of a, b, c
 (B) only when $bc \neq a$
 (C) only when $b + c = a$
 (D) only when $bc = a$
- Q.12 The maximum value of the function $2x + 3y + 4z$ on the ellipsoid $2x^2 + 3y^2 + 4z^2 = 1$ is
- (A) 2 (B) 3 (C) 6 (D) 9
- Q.13 Let $f : \mathbb{R} \rightarrow \mathbb{R}$ be a twice differentiable real valued function such that $f(1/n) = 1$ for $n = 1, 2, 3, \dots$. Then
- (A) $f'(0) = 0$ (B) $f'(0) = 1$
 (C) $0 < f'(0) < 1$ (D) $f'(0) > 1$
- Q.14 Let $f(x) = \int_0^{x^2} \sin \sqrt{t} dt$ for $x \geq 0$. Then $f'(\pi/2)$ is equal to
- (A) 0 (B) π (C) 1 (D) $\pi/2$
- Q.15 The value of the contour integral $\oint_{|z|=1} \frac{\cosh z}{4z^2 + 1} dz$ is equal to
- (A) $2\pi \cosh(i/2)$ (B) $\pi \cosh(i/2)$ (C) 0 (D) $2\pi i$

- Q.16 Let $f(x + iy) = u(x, y) + iv(x, y)$ be an analytic function defined on the complex plane satisfying $2u^2 + 3v^2 = 1$. Then
- (A) f is a constant
 (B) $f(z) = kz$ for some nonzero real number k
 (C) $u(x, y) = \frac{\cos(x + y)}{\sqrt{2}}$
 (D) $v(x, y) = \frac{\sin(x - y)}{\sqrt{3}}$
- Q.17 The value of $\oint_C (xy^2 + 2x)dx + (x^2y + 4x)dy$ along the circle $C : x^2 + y^2 = 4$ in the anticlockwise direction is
- (A) -16π (B) -4π (C) 4π (D) 16π
- Q.18 The volume of the prism whose base is the triangle in the xy -plane bounded by the x -axis and the lines $y = x$ and $x = 2$ and whose top lies in the plane $z = 5 - x - y$ is
- (A) 2 (B) 4 (C) 6 (D) 10
- Q.19 The general solution of $x(z^2 - y^2)\frac{\partial z}{\partial x} + y(x^2 - z^2)\frac{\partial z}{\partial y} = z(y^2 - x^2)$ is
- (A) $F(x^2 + y^2 + z^2, xyz) = 0$ (B) $F(x^2 + y^2 - z^2, xyz) = 0$
 (C) $F(x^2 - y^2 + z^2, xyz) = 0$ (D) $F(-x^2 + y^2 + z^2, xyz) = 0$
- Q.20 Choose a point uniformly distributed at random on the disc $x^2 + y^2 \leq 1$. Let the random variable X denote the distance of this point from the center of the disc. Then the variance of X is
- (A) $1/16$ (B) $1/17$ (C) $1/18$ (D) $1/19$

Q.21 If Runge-Kutta method of order 4 is used to solve the differential equation $\frac{dy}{dx} = f(x)$, $y(0) = 0$ in the interval $[0, h]$ with step size h , then

(A) $y(h) = \frac{h}{6}[f(0) + 4f(h/2) + f(h)]$

(B) $y(h) = \frac{h}{6}[f(0) + f(h)]$

(C) $y(h) = \frac{h}{2}[f(0) + f(h)]$

(D) $y(h) = \frac{h}{6}[f(0) + 2f(h/2) + f(h)]$

Q.22 If a polynomial of degree three interpolates a function $f(x)$ at the points $(0, 3)$, $(1, 13)$, $(3, 99)$ and $(4, 187)$, then $f(2)$ is

(A) 20

(B) 36

(C) 43

(D) 58

Common Data Questions

Common Data for Questions 23, 24:

Let $f: \mathbb{R} \rightarrow \mathbb{R}$ be defined by $f(x) = x^2$ for $-\pi \leq x \leq \pi$ and $f(x + 2\pi) = f(x)$.

Q.23 The Fourier series of f in $[-\pi, \pi]$ is

(A) $\frac{\pi^2}{3} + 4 \sum_{n=1}^{\infty} \frac{\cos nx}{n^2}$

(B) $\frac{\pi^2}{3} + \sum_{n=1}^{\infty} \frac{(-1)^n \cos nx}{n^2}$

(C) $\frac{\pi^2}{3} + 4 \sum_{n=1}^{\infty} \frac{(-1)^n \cos nx}{n^2}$

(D) $\frac{\pi^2}{3} + \sum_{n=1}^{\infty} \frac{\cos nx}{n^2}$

Q.24 The sum of the absolute values of the Fourier coefficients of f is

(A) $\pi^2/6$

(B) $\pi^2/3$

(C) $2\pi^2/3$

(D) π^2

Linked Answer Questions: Q. 25 to Q. 28 carry two marks each.

Statement for Linked Answer Questions 25 & 26

Let $y(x) = \sum_{n=0}^{\infty} a_n x^n$ be a solution of the differential equation $\frac{d^2 y}{dx^2} + xy = 0$.

Q.25 The value of a_{11} is

(A) 0

(B) 1

(C) 2

(D) 3

Q.26 The solution of the differential equation given above satisfying $y(0) = 1$ and $y'(0) = 0$ is

(A) $y(x) = 1 + \frac{1}{2.3}x^2 - \frac{1}{2.3.5.6}x^4 + \frac{1}{2.3.5.6.8.9}x^6 - \dots$

(B) $y(x) = 1 - \frac{1}{2.3}x^2 + \frac{1}{2.3.5.6}x^4 - \frac{1}{2.3.5.6.8.9}x^6 + \dots$

(C) $y(x) = 1 + \frac{1}{2.3}x^3 - \frac{1}{2.3.5.6}x^6 + \frac{1}{2.3.5.6.8.9}x^9 - \dots$

(D) $y(x) = 1 - \frac{1}{2.3}x^3 + \frac{1}{2.3.5.6}x^6 - \frac{1}{2.3.5.6.8.9}x^9 + \dots$

Statement for Linked Answer Questions 27 & 28:

The potential $u(x, y)$ satisfies the equation $\frac{\partial^2 u}{\partial x^2} + \frac{\partial^2 u}{\partial y^2} = 0$ in the square $0 \leq x \leq \pi$,

$0 \leq y \leq \pi$. Three of the edges $x = 0$, $x = \pi$ and $y = 0$ of the square are kept at zero potential and the edge $y = \pi$ is kept at nonzero potential.

Q.27 The potential $u(x, y)$ is given by

(A) $u(x, y) = \sum_{n=1}^{\infty} A_n \cosh nx \sin ny$

(B) $u(x, y) = \sum_{n=1}^{\infty} A_n \sin nx \cosh ny$

(C) $u(x, y) = \sum_{n=1}^{\infty} A_n \sinh nx \sin ny$

(D) $u(x, y) = \sum_{n=1}^{\infty} A_n \sin nx \sinh ny$

Q.28 If the edge $y = \pi$ is kept at the potential $\sin x$, then the potential $u(x, y)$ is given by

(A) $u(x, y) = \sum_{n=1}^{\infty} \frac{\sin nx \sinh ny}{\sinh n\pi}$

(B) $u(x, y) = \frac{\sin x \sinh y}{\sinh \pi}$

(C) $u(x, y) = \frac{\sin x \cosh y}{\cosh \pi}$

(D) $u(x, y) = \sum_{n=1}^{\infty} \frac{\cosh nx \sin ny}{\cosh n\pi}$

END OF THE SECTION

B: Computational Science

Q. 1 – Q. 6 carry one mark each

Q.1 If the 7-base representation of a number is 123, then its octal representation is

- (A) 102 (B) 103 (C) 111 (D) 112

Q.2 Consider the following four FORTRAN statements

S1: $X = 5 ** 3$

S2: $X = (-5) ** 3.0$

S3: $X = 5 ** -3$

S4: $X = 5 ** 3.0$

Which of the following sets contains the set of valid statements from above?

- (A) {S1, S3} (B) {S1, S4} (C) {S2, S3} (D) {S2, S4}

Q.3 Which of the following sets contains the set of the basic data types in C?

- (A) {char, int, float, logical} (B) {char, boolean, int, float}
(C) {char, int, long, short, float, double} (D) {char, int, float, void}

Q.4 If a root of $f(x) = x^2 - 2x + 1 = 0$ is obtained by using the iterative scheme

$x_{n+1} = x_n - \frac{f(x_n)}{f'(x_n)}$ with initial value $x_0 = 0.5$, then the convergence rate is

- (A) 1 (B) 1.62 (C) 1.84 (D) 2

Q.5 Let S_1 be the sum of the eigen values of a 2×2 matrix P and S_2 be the sum of the eigen values of another 2×2 matrix Q. If $S_1 = S_2$, then P and Q are

- (A) $\begin{pmatrix} 4 & 1 \\ 3 & 5 \end{pmatrix}$ and $\begin{pmatrix} 1 & 4 \\ 2 & 3 \end{pmatrix}$ (B) $\begin{pmatrix} 3 & 4 \\ 5 & 1 \end{pmatrix}$ and $\begin{pmatrix} 2 & 4 \\ 3 & 1 \end{pmatrix}$
(C) $\begin{pmatrix} 4 & 1 \\ 3 & 5 \end{pmatrix}$ and $\begin{pmatrix} 3 & 4 \\ 1 & 5 \end{pmatrix}$ (D) $\begin{pmatrix} 1 & 3 \\ 4 & 5 \end{pmatrix}$ and $\begin{pmatrix} 4 & 3 \\ 1 & 2 \end{pmatrix}$

Q.6 If y_i denotes the value of $y(x)$ at $x = x_i$ in $x_0 < x_1 < \dots < x_i < \dots < x_n$ and $x_i - x_{i-1} = h$ for $1 \leq i \leq n$, then $\frac{d^2 y}{dx^2}$ at $x = x_i$, $1 \leq i \leq n-1$ is approximated using finite difference scheme by

- (A) $\frac{1}{2h} (y_{i+1} - 2y_i + y_{i-1})$ (B) $\frac{1}{2h} (y_{i+1} - y_i + y_{i-1})$
(C) $\frac{1}{h^2} (y_{i+1} - 2y_i + y_{i-1})$ (D) $\frac{1}{h^2} (y_{i+1} - y_i + y_{i-1})$

Q. 7 – Q. 24 carry two marks each

- Q.7 The minimum number of terms required in the series expansion of e^x to evaluate at $x = 1$ correct up to 3 places of decimals is
 (A) 8 (B) 7 (C) 6 (D) 5
- Q.8 The iteration scheme $x_{n+1} = 1/(1+x_n^2)$ converges to a real number x in the interval $(0, 1)$ with $x_0 = 0.5$. The value of x correct up to 2 places of decimal is equal to
 (A) 0.65 (B) 0.68 (C) 0.73 (D) 0.80
- Q.9 If the diagonal elements of a lower triangular square matrix A are all different from zero, then the matrix A will always be
 (A) symmetric (B) non-symmetric (C) singular (D) non-singular

- Q.10 If two eigen values of the matrix

$$M = \begin{pmatrix} 2 & 6 & 0 \\ 1 & p & 0 \\ 0 & 0 & 3 \end{pmatrix}$$

are -1 and 4 , then the value of p is

- (A) 4 (B) 2 (C) 1 (D) -1
- Q.11 Consider the system of linear simultaneous equations
 $x + 10y = 5$; $y + 5z = 1$; $10x - y + z = 0$
 On applying Gauss–Seidel method the value of x correct up to 4 decimal places is
 (A) 0.0385 (B) 0.0395 (C) 0.0405 (D) 0.0410
- Q.12 The graph of a function $y = f(x)$ passes through the points $(0, -3)$, $(1, -1)$ and $(2, 3)$. Using Lagrange interpolation, the value of x at which the curve crosses the x -axis is obtained as
 (A) 1.375 (B) 1.475 (C) 1.575 (D) 1.675
- Q.13 The equation of the straight line of best fit using the following data

x	1	2	3	4	5
y	14	13	9	5	2

by the principle of least square is

- (A) $y = 18 - 3x$ (B) $y = 18.1 - 3.1x$
 (C) $y = 18.2 - 3.2x$ (D) $y = 18.3 - 3.3x$

- Q.14 On solving the initial value problem $\frac{dy}{dx} = xy^2$, $y(1) = 1$ by Euler's method, the value of y at $x = 1.2$ with $h = 0.1$ is
 (A) 1.1000 (B) 1.1232 (C) 1.2210 (D) 1.2331
- Q.15 The local error of the following scheme $y_{n+1} = y_n + \frac{h}{12}(5y'_{n+1} + 8y'_n - y'_{n-1})$ by comparing with the Taylor series $y_{n+1} = y_n + hy'_n + \frac{h^2}{2!}y''_n + \dots$ is
 (A) $O(h^4)$ (B) $O(h^5)$ (C) $O(h^2)$ (D) $O(h^3)$
- Q.16 The area bounded by the curve $y = 1 - x^2$ and the x-axis from $x = -1$ to $x = 1$ using Trapezoidal rule with step length $h = 0.5$ is
 (A) 1.20 (B) 1.23 (C) 1.25 (D) 1.33
- Q.17 The iteration scheme $x_{n+1} = \sqrt{a} \left(1 + \frac{3a^2}{x_n^2}\right) - \frac{3a^2}{x_n}$, $a > 0$ converges to the real number
 (A) \sqrt{a} (B) a (C) $a\sqrt{a}$ (D) a^2
- Q.18 If the binary representation of two numbers m and n are 01001101 and 00101011, respectively, then the binary representation of $m - n$ is
 (A) 00010010 (B) 00100010 (C) 00111101 (D) 00100001
- Q.19 Which of the following statements are true in a C program?
 P: A *local variable* is used only within the block where it is defined, and its sub-blocks
 Q: *Global variables* are declared outside the scope of all blocks
 R: *Extern variables* are used by linkers for sharing between other compilation units
 S: By default, all *global variables* are *extern variables*
 (A) P and Q (B) P, Q and R (C) P, Q and S (D) P, Q, R and S

Q.20 Consider the following recursive function $g()$.

```
Recursive integer function g(m,n) result (r)
integer:: m,n
if (n == 0) then
    r = m
else if (m <= 0) then
    r = n+1
else if ((n - n/2*2) == 1) then
    r = g(m-1, n+1)
else r = g(m-2, n/2)
end if
end
```

Which value will be returned if the function g is called with 6, 6?

- (A) 2 (B) 4 (C) 6 (D) 8

Q.21 If the following function is called with $x = 1$

```
real function print_value(x)
real:: x, sum, term
integer :: i
i = 0
sum = 2.0
term = 1.0
do while (term > 0.00001)
    term = x * term / (i+1)
    sum = sum + term
    i = i + 1
end do
print_value = sum
end
```

the value returned will be close to

- (A) $\log_e 2$ (B) $\log_e 3$ (C) $1 + e$ (D) e

Q.22 Consider the following C program

```
#include <stdio.h>
#include <string.h>

void main()
{
    char s[80], *p;
    int sum = 0;
    p = s;
    gets(s);
    while (*p)
    {
        if (*p == '1')
            sum = 2*sum + 1;
        else if (*p == '0')
            sum = sum*2;
        else
            printf("invalid string");
        p++;
    }
    printf("%d", sum);
}
```

Which number will be printed if the input string is 10110?

- (A) 31 (B) 28 (C) 25 (D) 22

Common Data Questions

Common Data for Questions 23, 24:

Consider the following C program segment

```
#include <stdio.h>
void print_mat (int[][3]);
void main ()
{
    int i, j, sum = 0;
    int m[3][3] = {{1, 3, 5}, {7, 9, 11}, {13, 15, 17}};
    for ( i = 0; i < 3; i++)
        for (j = 2; j > 1; j--)
            sum += m[i][j]*m[i][j-1];
    printf ("%d", sum);
    print_mat (m); // FUNCTION CALL
}

void print_mat (int mat[][3])
{
    int (*p)[3] = &mat[1];
    printf( "%d and %d", (*p)[1], (*p)[2]);
}
```

Q.23 The value of `sum` that will be printed by the above program is

- (A) 369 (B) 361 (C) 303 (D) 261

Q.24 The values printed after the function call (marked as `FUNCTION CALL`) are

- (A) 3 and 5 (B) 7 and 9 (C) 9 and 11 (D) 13 and 15

Linked Answer Questions: Q. 25 to Q. 28 carry two marks each

Statement for Linked Answer Questions 25 & 26:

Consider the following quadrature formula

$$\int_0^1 12f(x)dx = [f(0) + 2bf(0.25) + 2f(0.5) + 2df(0.75) + f(1)].$$

Q.25 If the above formula is used as Simpson's 1/3 rule, then

- (A) $b = d = 1$ (B) $b = d = 2$ (C) $b = 2d = 1$ (D) $b = 2d = 2$

Q.26 Using the correct values of b and d from Q.25 in the quadrature formula the value of

$$\int_0^1 \frac{12}{1+x} dx \text{ evaluated correct up to 4 decimal places is}$$

- (A) 8.3091 (B) 8.3121 (C) 8.3151 (D) 8.3191

Statement for Linked Answer Questions 27 & 28:

Consider the initial value problem $\frac{dy}{dx} = f(x, y) = 2xy$ with $y(0) = 1$, $y(0.2) = 1.0408$,
 $y(0.4) = 1.1735$ and $y(0.6) = 1.4333$

Q.27 Choose the correct predictor scheme to solve the above initial value problem at $x = 0.8$ from the following

(A) $y_{n+1} = y_n + \frac{4h}{3}(2f_{n-1} - f_{n-2} + 2f_{n-3})$

(B) $y_{n+1} = y_{n-3} + \frac{4h}{3}(2f_{n-2} - f_{n-1} + 2f_n)$

(C) $y_{n+1} = y_{n-1} + \frac{h}{3}(4f_{n-1} - 5f_n + 4f_{n+1})$

(D) $y_{n+1} = y_{n-3} + \frac{4h}{3}(2f_{n-1} - f_{n-2} + 2f_{n-3})$

Q.28 Using the correct predictor scheme from Q.27, the value of $y(0.8)$ is

- (A) 1.8680 (B) 1.8750 (C) 1.8890 (D) 1.9055

END OF THE SECTION

Section C: Electrical Sciences

Q. 1 – Q. 6 carry one mark each.

- Q.1 Assuming all components are ideal, the average power delivered by the dc voltage source in the network shown in the figure is

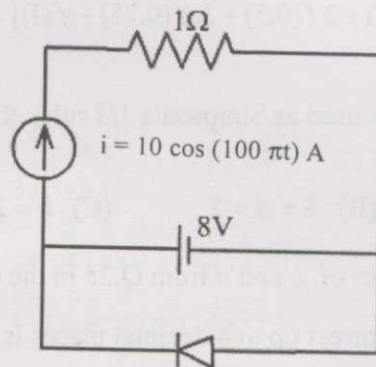

- (A) -28 W (B) 0 W (C) 64 W (D) 80 W
- Q.2 An ideal transformer with 10 turns in primary and 30 turns in secondary has its primary connected to external circuits as shown in the figure.

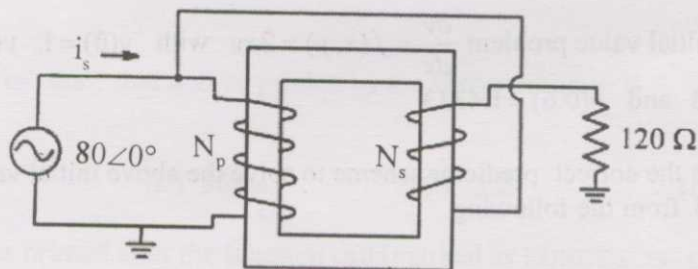

The current provided from the sinusoidal voltage source is

- (A) $0.67\angle 0^\circ$ (B) $2.0\angle 0^\circ$ (C) $2.67\angle 0^\circ$ (D) $10.67\angle 0^\circ$
- Q.3 In a three-phase, Y-connected squirrel cage induction motor, if N_s is the synchronous speed, N_r is the rotor speed and s is the slip, then the speeds of the airgap field and the rotor field with respect to the stator structure will respectively be
- (A) N_s, sN_r (B) N_s, N_s (C) N_r, N_r (D) N_s, sN_s
- Q.4 The equivalent conductance of the forward biased diode, with bias voltage V , at the room temperature is
- (A) constant
 (B) proportional to V
 (C) proportional to V^2
 (D) proportional to $\exp(KV)$.

- Q.5 A number is represented as $(1010\ 1010)_2$ using 8-bits in signed magnitude representation. The decimal number represented is
- (A) -42 (B) -85 (C) -86 (D) -176
- Q.6 A 10-bit DAC has a full scale output of 5 V. The DAC's resolution and step size will respectively be
- (A) 0.0978%, 500 mV
 (B) 0.0978%, 4.88 mV
 (C) 0.195%, 9.76 mV
 (D) 0.195%, 500 mV

Q. 7 – Q. 24 carry two marks each.

- Q.7 A power source has open circuit voltage of 24V and short circuit current of 16A. At intermediate operating conditions its terminal characteristics is as shown in the figure. The condition under which maximum power can be extracted from the power source is when the

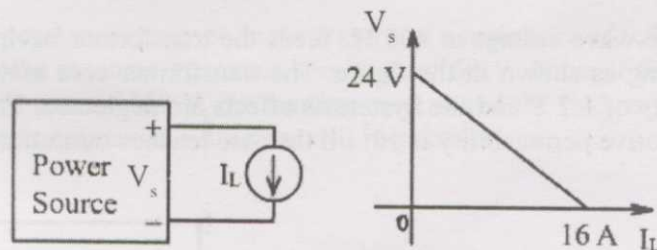

- (A) load current is 16 A
 (B) source voltage is 24 V
 (C) load power is 96 W
 (D) load power is 384 W
- Q.8 A 100 kVA, 11 kV/415 V transformer has 2% winding resistance and 4% leakage reactance. The voltage regulation at rated kVA, 0.8 pf lagging load is
- (A) 2% (B) 4% (C) 4.8% (D) 6%

Q.9 The source voltage of the three-phase network shown in the figure is 11 kV.

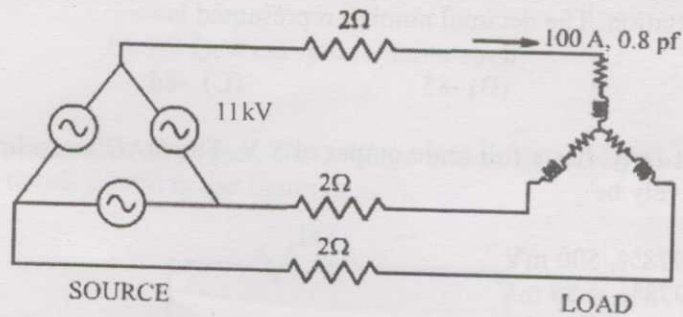

The line voltage at the load end and the phase angle with respect to the source voltage will be

- (A) 10.7 kV, 0° .
- (B) 10.7 kV, 1.08° lagging
- (C) 10.7 kV, 1.08° leading
- (D) 11 kV, 1.08° lagging

Q.10 A sine-wave voltage at 400 Hz feeds the transformer having 50 turns in the primary winding as shown in the figure. The transformer core material has a saturation flux density of 1.2 T and the hysteresis effects are neglected. The core area is $10\ \text{cm}^2$ and its relative permeability is 10^3 till the core reaches saturation.

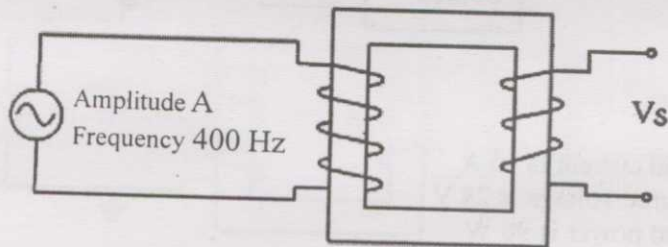

The maximum amplitude of the sine-wave that can be applied on the primary winding without causing saturation under steady state condition is

- (A) 24 V
- (B) 48 V
- (C) 75.4 V
- (D) 150.8 V

Q.11 A 415 V/240 V transformer rated at 1 kVA, 50 Hz has a leakage reactance of 4%. The leakage inductance of the secondary winding is

- (A) 7.3 mH
- (B) 21.9 mH
- (C) 183 mH
- (D) 2300 mH

- Q.12 A transformer with a 100 turn primary and 50 turn secondary is wound on an ideal C core with 1.0 mm airgap. The core area is 1.0 cm^2 . The transformer primary is connected to a voltage source, $v_p = 10\cos(2000\pi t) \text{ V}$. Assume that the reluctance of the airgap is dominant compared to that of the core and neglect the fringing effects.

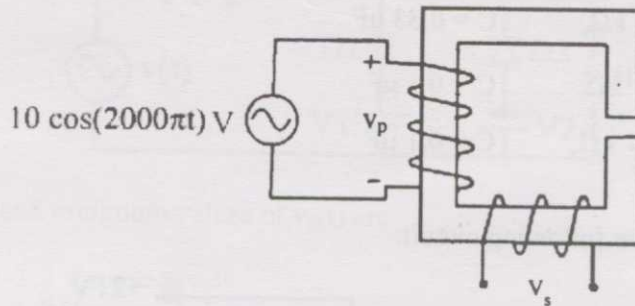

The peak value of the MMF of the primary winding is

- (A) 126.65 AT (B) 253.3 AT (C) 314 AT (D) 1000 AT
- Q.13 The armature of a permanent magnet dc generator has a resistance of 0.5Ω . When the speed is 600 rpm, the machine generates a voltage of 60 V. Now, if the armature is connected to a dc source of 150 V, the starting current and the line current when the machine is running at a speed of 1200 rpm, will respectively be
- (A) 120 A, 60 A
 (B) 300 A, 60 A
 (C) 120 A, 120 A
 (D) 300 A, 120 A
- Q.14 A 4-pole dc machine has a lap wound armature of radius 14.2 cm and an effective length of 26.3 cm. The poles cover 80% of the armature periphery. The armature winding consists of 39 coils each having 5 turns. The coils are accommodated in 39 slots. The average flux density under each pole is 0.68 T. The flux per pole of this machine will be
- (A) 15.95 mWb (B) 31.9 mWb (C) 39.9 mWb (D) 63.8 mWb
- Q.15 A dc shunt motor rotating at 1400 rpm is fed by a 220 V dc source. The line current is 101 A and the shunt field resistance is 220Ω . If the armature resistance is 0.2Ω , the mechanical power developed by the motor will be
- (A) 22.22 kW (B) 22 kW (C) 20 kW (D) 2 kW

Q.16 A transistor oscillator uses a 3-section R-C phase shift circuit. Each section uses same R and C values. The gain of the circuit is adjusted for oscillation. The required oscillation frequency is 10 k rad/s. The suitable R-C combination is

- (A) $R = 3 \text{ k}\Omega$, $C = 0.33 \text{ }\mu\text{F}$
- (B) $R = \frac{1}{3} \text{ k}\Omega$, $C = 0.33 \text{ }\mu\text{F}$
- (C) $R = \sqrt{3} \text{ k}\Omega$, $C = 0.1 \text{ }\mu\text{F}$
- (D) $R = \frac{1}{\sqrt{3}} \text{ k}\Omega$, $C = 0.1 \text{ }\mu\text{F}$

Q.17 Consider the following circuit:

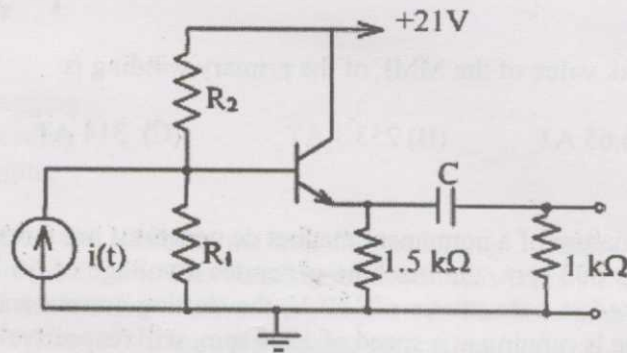

Given, β for the transistor is 50, and the capacitance C is very large (leading to infinity), the value of the quiescent collector current, I_{CQ} is

- (A) 7 mA
- (B) 10 mA
- (C) 14 mA
- (D) 35 mA

Q.18 The CMOS circuit shown below represents

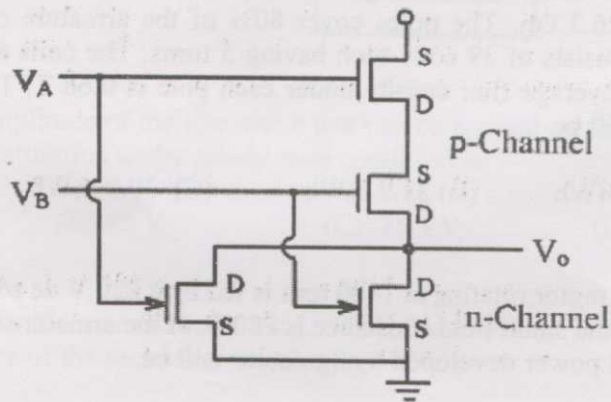

- (A) AND gate
- (B) NAND gate
- (C) OR gate
- (D) NOR gate

- Q.19 In the circuit shown in figure, $v(t) = 3 \cos \omega t$ and cut-in voltage of each diode is 0.7 V. Given $V1 = 2$ V and $V2 = 1$ V.

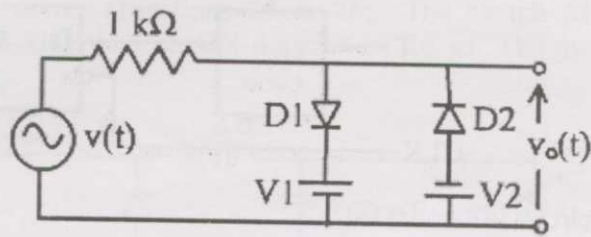

The maximum and minimum values of $v_o(t)$ are

- (A) +2.3 V and -1.7 V respectively
 - (B) +2.7 V and -1.7 V respectively
 - (C) +1.3 V and -0.3 V respectively
 - (D) +2.3 V and -1.3 V respectively
- Q.20 Given $v(t) = 2 \cos 2000\pi t$ and OPAMP is ideal.

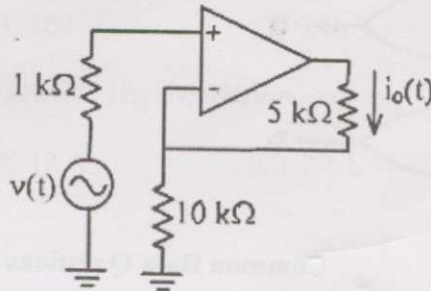

The current $i_o(t)$ in 5 kΩ resistor is

- (A) $0.66 \cos 2000\pi t$ mA
 - (B) $0.33 \cos 2000\pi t$ mA
 - (C) $0.2 \cos 2000\pi t$ mA
 - (D) $0.1 \cos 2000\pi t$ mA
- Q.21 The simplified logic expression for the circuit shown in the figure is

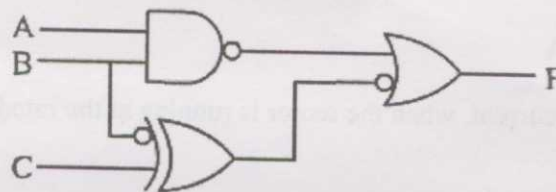

- (A) $\overline{A.B} + B.C$
- (B) $\overline{A.B} + C$
- (C) $\overline{A} + \overline{B} + C$
- (D) $\overline{A} + \overline{B} + \overline{C}$

- Q.22 A D flip-flop is converted to T flip-flop by connecting a logic circuit at the input as shown in the figure.

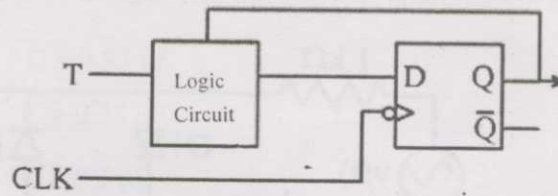

The logic circuit is

- (A)
- (B)
- (C)
- (D)

Common Data Questions

Common Data for Questions 23, 24: A three-phase, 4-pole, 400 V, 50 Hz, 1450 rpm, Y-connected induction motor has the following parameters referred to the stator side:

$$R_2 = 0.35 \Omega, \quad X_2 = 0.25 \Omega, \quad X_m = 25 \Omega$$

Stator impedance and the iron loss component are neglected.

- Q.23 For a direct-on-line starting with full voltage, the starting current will be
- (A) 542.36 A
 (B) 659.83 A
 (C) 939.4 A
 (D) 1142.85 A
- Q.24 The full load current, when the motor is running at the rated speed will be
- (A) 13.88 A
 (B) 24.04 A
 (C) 33.99 A
 (D) 41.64 A

Linked Answer Questions: Q. 25 to Q. 28 carry two marks each.

Statement for Linked Answer Questions 25 & 26: The switch S1 turns on and off repeatedly at a rate of 20 kHz with an ON duration of 20 μ s. The switch and diode are considered ideal.

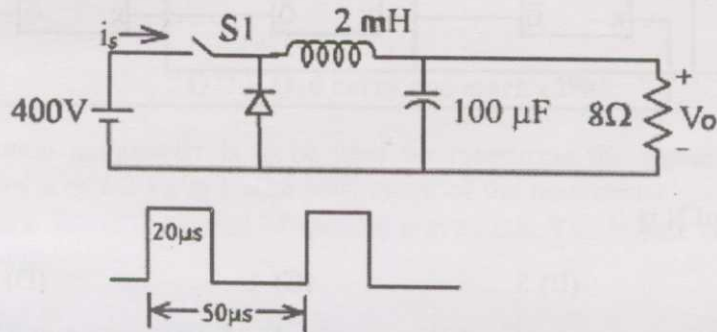

- Q.25 The average voltage (V_o) seen by the load is
- (A) 667 V (B) 400 V (C) 240 V (D) 160 V
- Q.26 The average current (I_s) provided by the 400V source is
- (A) 8 A (B) 12 A (C) 20 A (D) 160 A

Statement for Linked Answer Questions 27 & 28: A divide by N-counter is designed using J-K flip-flops as shown in the figure.

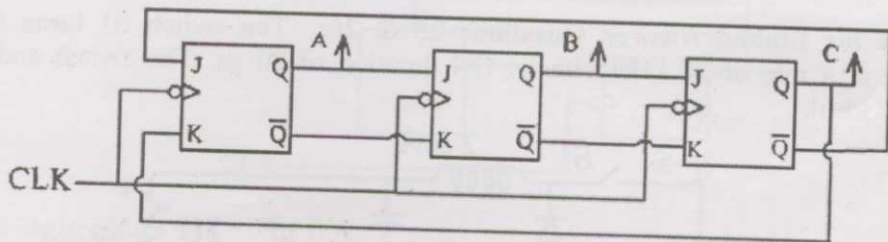

Q.27 The value of N is

- (A) 4 (B) 5 (C) 6 (D) 7

Q.28 The output of the above counter is given to the circuit shown below, which consists of 3 line to 8 line decoder and LEDs.

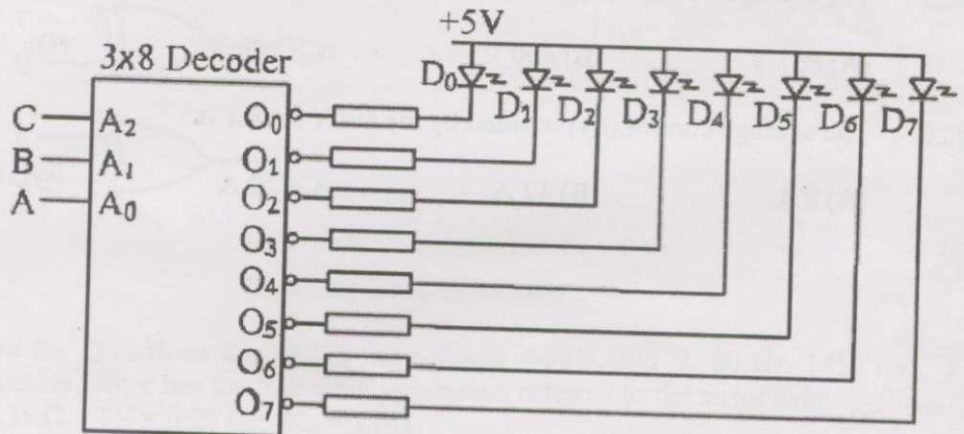

The LEDs that will never glow are

- (A) D_0 and D_7
 (B) D_0 and D_2
 (C) D_2 and D_5
 (D) D_5 and D_7

END OF THE SECTION

D : Fluid Mechanics

Useful Data:

Acceleration due to gravity $g = 10 \text{ m/s}^2$

Density of water $\rho_w = 1000 \text{ kg/m}^3$

Q. 1 – Q. 6 carry one mark each.

- Q.1 A projection manometer is to be used for measuring the dynamic pressure of an airstream ($\rho = 1.2 \text{ kg/m}^3$). The least count of the manometer scale is 0.1 mm. The manometric liquid is alcohol of specific gravity 0.8. The lowest velocity that can be measured is
- (A) $\sqrt{3}/2 \text{ m/s}$ (B) $2/\sqrt{3} \text{ m/s}$ (C) $\sqrt{3} \text{ m/s}$ (D) 2 m/s
- Q.2 The velocity of sound
- (A) is a thermodynamic state variable
(B) is constant for a particular fluid
(C) depends on the velocity field for the flow
(D) depends on whether the flow is laminar or turbulent
- Q.3 Consider the mass balance equation $\frac{\partial u}{\partial x} + \frac{\partial v}{\partial y} = 0$. The most appropriate set of conditions for this equation to hold good is:
- (A) steady or unsteady, and compressible or incompressible
(B) steady or unsteady, and compressible
(C) steady or unsteady, and incompressible
(D) steady, and compressible or incompressible
- Q.4 The non-dimensional number obtained from specific heat (c_p), thermal conductivity (k) and viscosity (μ) is
- (A) $\sqrt{k c_p} / \mu$ (B) $\sqrt{k \mu} / c_p$ (C) $k \mu / c_p$ (D) $\mu c_p / k$
- Q.5 For a two-dimensional turbulent boundary layer, the wall shear stress can be expressed as $\tau_w = \mu \left. \frac{\partial u}{\partial y} \right|_{wall}$ where u is the velocity parallel to the wall and y is the coordinate perpendicular to the wall. In the above expression, μ denotes
- (A) the molecular viscosity of the fluid
(B) the turbulent eddy viscosity
(C) an effective viscosity which is greater than the molecular viscosity
(D) an effective viscosity that is less than the molecular viscosity

Q.6 Flow-separation from a solid surface may take place if the flow is

- (A) viscous, in a positive streamwise pressure gradient
- (B) viscous, in a negative streamwise pressure gradient
- (C) inviscid, in a positive streamwise pressure gradient
- (D) inviscid, in a negative streamwise pressure gradient

Q. 7 – Q. 24 carry two marks each.

Q.7 It is given that a solid sphere and a hollow cube have the same outer surface area. The ratio of buoyancy force on the sphere to that on the cube, when they are fully submerged in a liquid, is given by

- (A) $\sqrt{\frac{2}{\pi}}$ (B) $\sqrt{\frac{4}{\pi}}$ (C) $\sqrt{\frac{6}{\pi}}$ (D) $\sqrt{\frac{8}{\pi}}$

Q.8 Given that temperature $T(x,y)$ does not change along a streamline in a steady two-dimensional, incompressible flow, the equation of the streamline is obtained from

- (A) $\frac{dy}{dx} = \frac{-\left(\frac{\partial T}{\partial x}\right)}{\left(\frac{\partial T}{\partial y}\right)}$ (B) $\frac{dy}{dx} = \frac{-\left(\frac{\partial T}{\partial y}\right)}{\left(\frac{\partial T}{\partial x}\right)}$ (C) $\frac{dy}{dx} = \frac{\left(\frac{\partial T}{\partial x}\right)}{\left(\frac{\partial T}{\partial y}\right)}$ (D) $\frac{dy}{dx} = \frac{\left(\frac{\partial T}{\partial y}\right)}{\left(\frac{\partial T}{\partial x}\right)}$

Q.9 Consider a two-dimensional laminar boundary layer with a constant freestream velocity. For a fluid particle very close to the wall, the signs of the material acceleration components in directions parallel and perpendicular to the solid surface are, respectively

- (A) + and – (B) – and + (C) + and + (D) – and –

Q.10 Water enters a pipe of cross-sectional area A_1 that branches out into sections of equal areas A_2 and A_3 , as shown in the figure below.

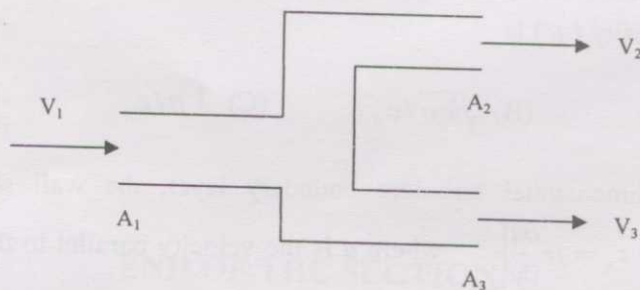

At one instant, the flow velocities are $V_1 = 2$ m/s, $V_2 = 3$ m/s and $V_3 = 5$ m/s. At another instant, $V_1 = 3$ m/s and $V_2 = 4$ m/s. What is the value of V_3 at this instant?

- (A) 5 m/s (B) 6 m/s (C) 7 m/s (D) 8 m/s

- Q.11 For a two-dimensional incompressible irrotational flow, the x-component of velocity $u = 2x + 3y$. The corresponding y-component of velocity is
- (A) $2y - 3x$ (B) $2y + 3x$
 (C) $-2y + 3x$ (D) $-2y - 3x$
- Q.12 For a certain two-dimensional steady incompressible flow, the horizontal and vertical velocity components are given by $u = 6y$, $v = 0$, where y is the vertical distance. The angular velocity and rate of shear strain respectively are
- (A) -3 and 3 (B) 3 and -3
 (C) 3 and -6 (D) -6 and 3
- Q.13 In a steady two-dimensional incompressible flow, the stream function (ψ) obeys the equation $\frac{\partial^2 \psi}{\partial x^2} + \frac{\partial^2 \psi}{\partial y^2} = 4$. A solution of this equation is
- (A) $\psi = x^2 + y^2$
 (B) $\psi = y^2 - x^2$
 (C) $\psi = xy$
 (D) $\psi = x + y$
- Q.14 A uniform stream of an ideal fluid with velocity U and pressure p_∞ flows past a circular cylinder as shown in the figure below.

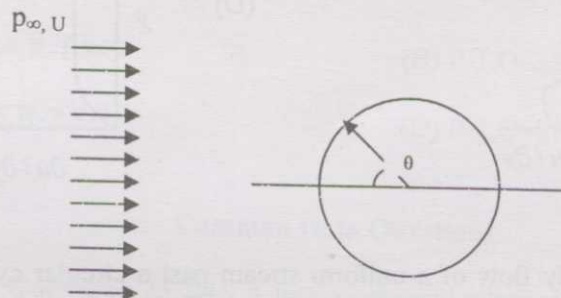

- The fluid velocity on the cylinder wall is given by $V_\theta = 2U \sin \theta$. The pressure coefficient is defined as $C_p = \frac{P - P_\infty}{0.5 \rho U^2}$. The minimum value of C_p on the surface of the cylinder is
- (A) 1 (B) -1 (C) -3 (D) -4
- Q.15 A model of characteristic length 20 cm is built to study the flow of water ($\nu = 10^{-6} \text{ m}^2/\text{s}$) in an open channel of 5 m characteristic length. What should be the kinematic viscosity of the fluid used in the model?
- (A) $4 \times 10^{-9} \text{ m}^2/\text{s}$ (B) $8 \times 10^{-9} \text{ m}^2/\text{s}$ (C) $4 \times 10^{-6} \text{ m}^2/\text{s}$ (D) $8 \times 10^{-6} \text{ m}^2/\text{s}$

Q.16 Water flows steadily through a smooth circular tube of 5 cm diameter at a flow rate of π kg/s. Take viscosity $\mu = 0.001$ Ns/m² and density $\rho = 1000$ kg/m³. The Darcy friction factor is given as: $f_D = 64/Re_d$ for fully developed laminar flow and $f_D = 0.316 Re_d^{-0.25}$ for fully developed turbulent flow. The approximate pressure drop per unit length in the fully developed region of the tube is

- (A) 20 Pa/m (B) 120 Pa/m (C) 480 Pa/m (D) 960 Pa/m

Q.17 Consider a constant pressure boundary layer over a flat plate of length $L = 3$ m. The freestream velocity is $U = 60$ m/s and the density and viscosity of the fluid respectively are $\rho = 1.23$ kg/m³ and $\mu = 1.79 \times 10^{-5}$ Ns/m². Transition occurs at a distance $x_{cr} = 0.1$ m from the leading edge. If the free stream velocity is changed to $U = 120$ m/s, x_{cr} becomes

- (A) 0.2 m (B) 0.1 m (C) 0.05 m (D) 0.005 m

Q.18 For a laminar boundary layer with constant freestream velocity (i.e. $dp/dx = 0$), the variation of $\partial u / \partial y$ with distance from the wall is given by

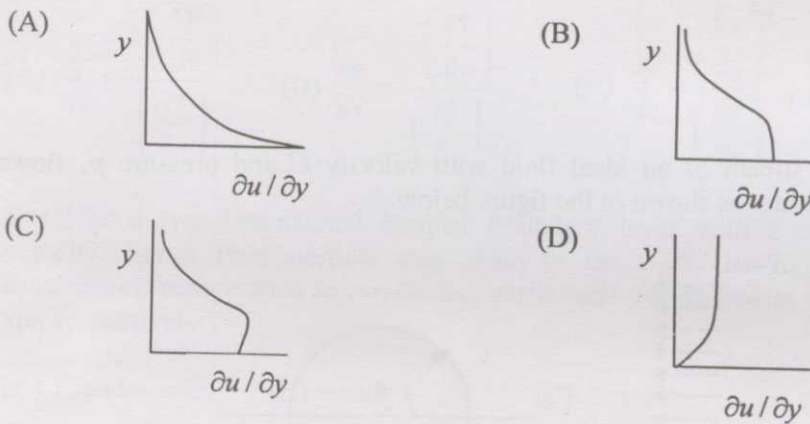

Q.19 Consider the steady flow of a uniform stream past a circular cylinder, for a viscous fluid. The following two cases are compared: (I) cylinder is rotating at a slow rate about its axis (II) cylinder is not rotating. Consider the statements

- P: The lift force in case I is zero
 Q: The lift force in case II is zero
 R: The drag force in case I is non-zero
 S: The drag force in case II is zero

Which one of the following combinations is TRUE?

- (A) PQR (B) PRS (C) PS (D) QR

- Q.20 An orifice plate of 60 mm diameter and discharge coefficient 0.6 is used for measuring the flow rate of air ($\rho = 1.2 \text{ kg/m}^3$, $\mu = 1.8 \times 10^{-5} \text{ kg m}^{-1} \text{ s}^{-1}$) through a pipe of 100 mm diameter. A manometer (with water as the working liquid) connected across the orifice plate reads 180 mm. The air flow rate is approximately equal to
- (A) $0.3 \text{ m}^3/\text{s}$ (B) $0.1 \text{ m}^3/\text{s}$ (C) $0.01 \text{ m}^3/\text{s}$ (D) $0.003 \text{ m}^3/\text{s}$
- Q.21 The velocity of an airstream ($\rho = 1.0 \text{ kg/m}^3$) is to be measured using a pitot-static tube. The level difference between the two arms of the manometer is 2 cm of water. The velocity is
- (A) 0.02 m/s (B) 2.0 m/s (C) 10 m/s (D) 20 m/s
- Q.22 Match the items in the following columns using the most appropriate combinations:
- | | | |
|----|--------------------------------------|--------------------------------|
| P. | $\frac{dp}{dz} = \frac{-\rho g}{RT}$ | 1. Volume flow rate |
| Q. | Lift | 2. Variable density atmosphere |
| R. | Stream function | 3. Mach Number |
| S. | Compressibility | 4. Circulation |
| | | 5. Reynolds Number |
- (A) P-3,Q-4,R-1,S-5 (B) P-1,Q-2,R-4,S-3
 (C) P-4,Q-5,R-2,S-3 (D) P-2,Q-4,R-1,S-3

Common Data Questions

Common Data for Questions 23, 24: A line source and a line sink, both of unit strength, are placed on the x-axis at $x = -1$ and $x = +1$ respectively.

Q.23 In terms of the Cartesian unit vectors \mathbf{i} and \mathbf{j} , the velocity at the point $(0,1)$ is given as

- (A) $0 \mathbf{i} + 0 \mathbf{j}$ (B) $\frac{1}{2\pi} \mathbf{i}$ (C) $\frac{1}{2\pi} \mathbf{j}$ (D) $\frac{1}{\pi} \mathbf{i}$

Q.24 If the source and sink are placed in a uniform approach stream, the resulting external flow corresponds to that

- (A) of a doublet
 (B) over a circular cylinder
 (C) over a Rankine half-body
 (D) over a Rankine oval

Linked Answer Questions: Q. 25 to Q. 28 carry two marks each.

Statement for Linked Answer Questions 25 & 26: A motorboat is cruising in a lake (see figure below) at a uniform speed of 10 m/s. A 180 kW pump sucks water at a rate $1 \text{ m}^3/\text{s}$ through an inlet pipe in the front and pumps it out with a velocity of 10 m/s with respect to the lake, through an outlet pipe at the rear.

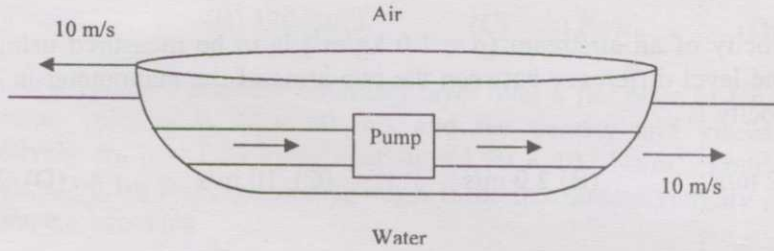

- Q.25 The total drag on the boat is
 (A) 30 kN (B) 20 kN (C) 10 kN (D) Zero
- Q.26 The power utilized for propelling the boat is
 (A) 130 kW (B) 100 kW (C) 80 kW (D) 30 kW

Statement for Linked Answer Questions 27 & 28: Consider a fully developed laminar flow in a pipe of radius R in which r and x represent the radial and axial co-ordinates respectively.

The axial velocity distribution is $u(r) = \left(\frac{-R^2}{4\mu} \frac{dp}{dx} \right) \left(1 - \frac{r^2}{R^2} \right)$ and the average axial velocity is

$$u_m = \left(\frac{-R^2}{8\mu} \frac{dp}{dx} \right).$$

- Q.27 The magnitude of shear stress on the wall (τ_{wall}) is
 (A) $\frac{32\mu}{\rho u_m R}$ (B) $\frac{4\mu u_m}{R}$
 (C) $\frac{\mu u_m}{R}$ (D) $-\frac{R^2}{4} \frac{d^2 p}{dx^2}$
- Q.28 The local friction factor $C_f = \frac{\tau_{wall}}{0.5\rho u_m^2}$, with $\gamma = -\frac{dp}{dx}$ is given by
 (A) $\frac{16\mu^2}{\rho R^3 \gamma}$ (B) $\frac{24\mu^2}{\rho R^3 \gamma}$
 (C) $-\frac{R^2}{2\rho u_m^2} \frac{d^2 p}{dx^2}$ (D) $\frac{64\mu^2}{\rho R^3 \gamma}$

END OF THE SECTION

E: Materials Science

Useful Information (in SI units)

Avogadro Number, N_A	:	6.023×10^{26} per kg-mole
Boltzmann Constant, k_B	:	1.38×10^{-23} J.K ⁻¹
Universal Gas Constant, R	:	8.314 J.mol ⁻¹ .K ⁻¹

Q. 1 – Q. 6 carry one mark each.

- Q.1 High bond energy in a crystal leads to
- (A) high elastic modulus, low melting point and high coefficient of thermal expansion
(B) low elastic modulus, high melting point and low coefficient of thermal expansion
(C) high elastic modulus, high melting point and low coefficient of thermal expansion
(D) low elastic modulus, low melting point and high coefficient of thermal expansion
- Q.2 Which of the following oxides does NOT form glass by itself?
- (A) SiO₂ (B) B₂O₃ (C) P₂O₅ (D) Al₂O₃
- Q.3 In a material, which of the following diffusion mechanisms would have lowest activation energy?
- (A) Lattice diffusion (B) Grain boundary diffusion
(C) Surface diffusion (D) Diffusion through dislocations
- Q.4 In a tensile test, necking starts at
- (A) lower yield point (B) upper yield point
(C) ultimate tensile stress (D) proof stress
- Q.5 Si is added to transformer grade steel to
- (A) decrease the magnetic permeability
(B) decrease the electrical resistivity
(C) improve the ductility
(D) increase the magnetic permeability
- Q.6 According to Galvanic series, the most active metal among the following is
- (A) Mg (B) Zn (C) Sn (D) Al

Q. 7 – Q. 24 carry two marks each.

- Q.7 The enthalpy of formation of vacancies in Cu is 120 kJ.mol^{-1} . The equilibrium fraction of vacant lattice sites in Cu at 1000 K would be
- (A) 1.35×10^{-8} (B) 5.39×10^{-7}
 (C) 7.76×10^{-6} (D) 2.58×10^{-9}
- Q.8 Melting point of a metal is 1000 K and its enthalpy of melting is $2.0 \times 10^9 \text{ J.m}^{-3}$. If the solid-liquid interface energy is 0.5 J.m^{-2} , the radius of critical nucleus during solidification at 900 K would be
- (A) 10.0 nm (B) 5.0 nm (C) 5.0 μm (D) 2.5 nm
- Q.9 In a binary system A–B at one atmosphere, the parameter(s) that can be independently varied in the two phase ($\alpha+\beta$) region is(are)
- (A) composition of α -phase as well as temperature
 (B) composition of α -phase as well as composition of β -phase
 (C) either composition of α -phase or composition of β -phase or temperature
 (D) only temperature
- Q.10 Cd^{++} doped NaCl crystal has higher conductivity at room temperature as compared to pure NaCl due to
- (A) lower activation energy for movement of cations
 (B) increase in the concentration of cation vacancies
 (C) introduction of holes in the crystal
 (D) increase in concentration of anion vacancies
- Q.11 Match the heat treatment with the resultant microstructure of a hypoeutectoid steel and choose the correct matching from (A), (B), (C) and (D).
- | <u>Heat Treatment</u> | <u>Microstructure</u> |
|---|------------------------------------|
| P Austempering | 1. Martensite |
| Q Martempering | 2. Ferrite + Spherodized Cementite |
| R Full Annealing | 3. Ferrite + Coarse Pearlite |
| S Quench Hardening + Tempering at 700°C | 4. Bainite |
| | 5. Tempered Martensite |
- (A) P-4, Q-1, R-3, S-2 (B) P-5, Q-1, R-3, S-2
 (C) P-1, Q-4, R-2, S-3 (D) P-2, Q-5, R-3, S-4
- Q.12 Second peak in the powder X-ray diffraction pattern of a material with FCC crystal structure appears at a Bragg angle of 23.21° . If wavelength of Cu-K_α radiation used in the experiment is 0.154 nm, lattice parameter (in nm) of the material would be
- (A) 0.391 (B) 0.338
 (C) 0.276 (D) 0.437

- Q.13 Which of the following directions lies in $(1\bar{1}1)$ plane?
- (A) $[211]$ (B) $[\bar{1}21]$
 (C) $[121]$ (D) $[2\bar{1}\bar{1}]$
- Q.14 The yield strength of a metal varies with its average grain size 'd' as
- (A) $d^{-1/2}$ (B) d^{-1} (C) d (D) $d^{1/2}$
- Q.15 The mechanism which does NOT contribute to toughening in a SiC whisker reinforced alumina ceramic matrix composite is
- (A) crack tip deflection
 (B) transformation toughening
 (C) forming bridges across the crack face
 (D) absorbing energy during pull-out of whiskers from the matrix
- Q.16 Match the experimental techniques in Group I with the applications in Group II and choose the correct matching from (A), (B), (C) and (D).

Group I (Technique)

- P X-ray diffraction
 Q Transmitted polarized light microscopy
 R Four probe technique
 S Zone refining

Group II (Application)

1. Resistivity determination
2. Measurement of crystallite size
3. Observation of inclusion
4. Observation of spherulites
5. Purification of materials

- (A) P-2, Q-3, R-1, S-5 (B) P-4, Q-3, R-5, S-3
 (C) P-4, Q-3, R-1, S-2 (D) P-2, Q-4, R-1, S-5

- Q.17 Match the following types of polymers given in the Group I with their applications in Group II and choose the correct matching from (A), (B), (C) and (D).

Group I (Polymer)

- P Polycarbonates
 Q Fluorocarbons
 R Polyaniline
 S Polypropylene

Group II (Application)

1. Anti adhesive coating
2. Packaging film
3. Outdoor light globes
4. Magnetic recording tapes
5. Polymer LEDs

- (A) P-2, Q-1, R-4, S-3 (B) P-4, Q-1, R-3, S-2
 (C) P-3, Q-1, R-5, S-4 (D) P-3, Q-1, R-5, S-2

Q.18 Match the materials given in Group I with the applications in Group II and choose the correct matching from (A), (B), (C) and (D).

Group I (Material)

- P GaAs_{1-x}P_x
Q MgB₂
R Hydroxyapatite (HAp)
S KevlarTM Fibers

Group II (Application)

1. Prosthetic applications
2. Bulletproof jackets
3. LEDs
4. Abrasives
5. Superconducting magnets

(A) P-3, Q-5, R-1, S-2

(C) P-5, Q-4, R-1, S-2

(B) P-3, Q-5, R-4, S-2

(D) P-3, Q-5, R-4, S-1

Q.19 Optical transparency of a single crystal depends upon its

- (A) band gap
- (B) lattice parameter
- (C) crystal structure
- (D) work function

Q.20 In the intrinsic region, drift mobility of electrons in a doped semiconductor as a function of temperature

- (A) is limited due to scattering by ionized impurities
- (B) is limited due to scattering by phonons
- (C) is limited due to scattering by point defects
- (D) remains unaffected

Q.21 ZnFe₂O₄ has inverse spinel structure. Atomic numbers of Zn, Fe and O are 30, 26 and 8 respectively. The net magnetic moment of ZnFe₂O₄ per formula unit in terms of Bohr magneton (μ_B) will be

(A) $2 \mu_B$

(B) $1 \mu_B$

(C) $4 \mu_B$

(D) $0 \mu_B$

Q.22 Nb₃Sn is widely used as current carrying element in fabrication of superconducting magnets since it

- (A) is a Type I superconductor
- (B) is a Type II superconductor and has large critical magnetic field
- (C) has T_c above boiling point of liquid helium (coolant used in superconducting magnets)
- (D) is an intermetallic

Q. 23 and Q. 24 are Common Data Questions

Common Data for Questions 23, 24:

Mo has BCC structure and its lattice parameter is 0.315 nm. Atomic mass of Mo is 96.

- Q.23 The Mo-Mo nearest neighbour distance (in nm) is
(A) 0.223 (B) 0.273 (C) 0.136 (D) 0.1575
- Q.24 Theoretical density of Mo (in kg.m^{-3}) is
(A) 20400 (B) 2550 (C) 10200 (D) 5100

Linked Answer Questions: Q. 25 to Q. 28 carry two marks each.

Statement for Linked Answer Questions 25 & 26:

A continuous and aligned Carbon fiber reinforced hardened epoxy matrix composite consists of 40 vol% of Carbon fibers.

Elastic modulus of Carbon fibers = 400 GPa

Elastic modulus of hardened epoxy = 2.40 GPa

Density of Carbon fiber = 1800 kg.m^{-3}

Density of hardened epoxy = 1200 kg.m^{-3}

- Q.25 The density of the composite in kg.m^{-3} is
(A) 1440 (B) 1200 (C) 1800 (D) 1340
- Q.26 The specific modulus of elasticity of the composite in the longitudinal direction is
(A) $2.76 \text{ MPa.m}^3.\text{kg}^{-1}$ (B) 112.11 GPa
(C) 161.44 GPa (D) $112.11 \text{ MPa.m}^3.\text{kg}^{-1}$

Statement for Linked Answer Questions 27 & 28:

Intrinsic carrier density in Si at 300 K is $1.45 \times 10^{16} \text{ m}^{-3}$. The sample is doped with 1 ppm of As. Density of Si is 2330 kg.m^{-3} and its atomic weight is 28.

- Q.27 Number of As atoms per m^3 would be
(A) 5.01×10^{22} (B) 5.01×10^{26}
(C) 5.01×10^{19} (D) 3.929×10^{23}
- Q.28 Assuming all impurities are ionized, the hole concentration per m^3 would be
(A) 2.894×10^{-7} (B) 4.197×10^9
(C) 4.197×10^6 (D) 4.197×10^{12}

END OF THE SECTION

F: Solid Mechanics

Q. 1 – Q. 6 carry one mark each.

- Q.1 A simply supported beam AB is subjected to a horizontal force, P , as shown in the figure.

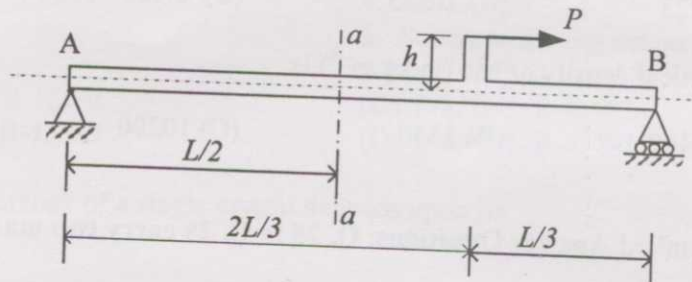

Shear force at section $a-a$ is given by

- (A) Ph/L (B) $3Ph/(2L)$ (C) $3Ph/L$ (D) PL/h
- Q.2 The two-dimensional state of stress at a point is given by

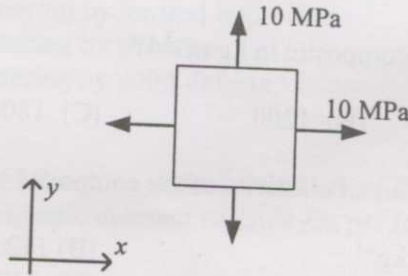

The corresponding Mohr's circle is

- (A) a circle of radius 10 MPa with center at 10 MPa on the σ -axis
 (B) a circle of radius 10 MPa with center at -10 MPa on the σ -axis
 (C) a point on the positive σ -axis
 (D) a point on the negative σ -axis
- Q.3 The kind of fracture surface observed in a brittle specimen that fails under a uniaxial tensile test is
- (A) cup and cone
 (B) flat rough surface perpendicular to the axis of the specimen
 (C) helical rough surface with a 45° inclination to the axis of the specimen
 (D) flat rough surface with a 45° inclination to the axis of the specimen

- Q.4 Two masses are attached to the two ends of a cable which passes over two frictionless pulleys as shown in the figure. (acceleration due to gravity = g)

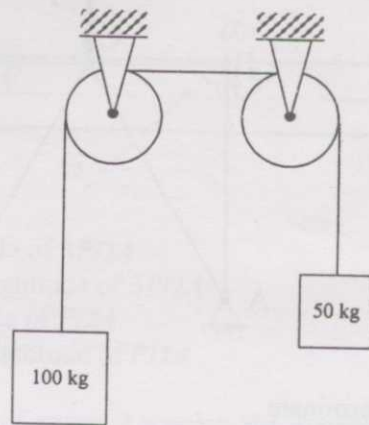

The acceleration of the 100 kg mass is

- (A) g (B) $g/2$ (C) $g/3$ (D) $g/4$
- Q.5 A block of mass m is released at rest from a point P of a rough circular path of radius r as shown in the figure. There is a spring of stiffness k at the other end of the path. (acceleration due to gravity = g)

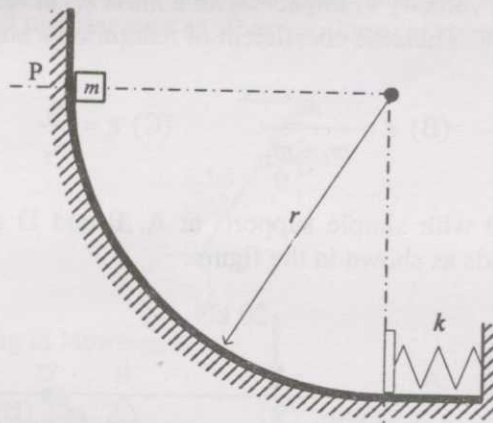

The maximum spring deflection is

- (A) independent of r
 (B) more than $\sqrt{2mgr/k}$
 (C) equal to $\sqrt{2mgr/k}$
 (D) less than $\sqrt{2mgr/k}$

Q.6 The truss shown in the figure is

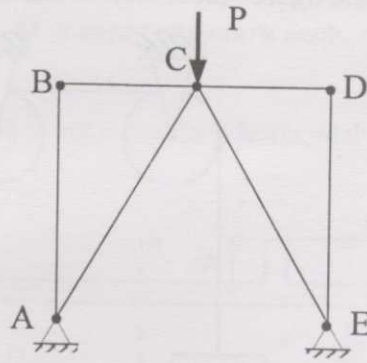

- (A) stable and indeterminate
- (B) stable and determinate
- (C) unstable and indeterminate
- (D) unstable and determinate

Q. 7 – Q. 24 carry two marks each.

Q.7 A mass m_1 with velocity v_1 impacts with a mass m_2 at rest. After the impact, the mass m_1 comes to rest. Then the coefficient of restitution e should be

- (A) $e = \frac{m_1}{m_1 + m_2}$
- (B) $e = \frac{m_2}{m_1 + m_2}$
- (C) $e = \frac{m_1}{m_2}$
- (D) $e = \frac{m_2}{m_1}$

Q.8 A beam ABCD with simple supports at A, B and D and an internal hinge at C is subjected to loads as shown in the figure.

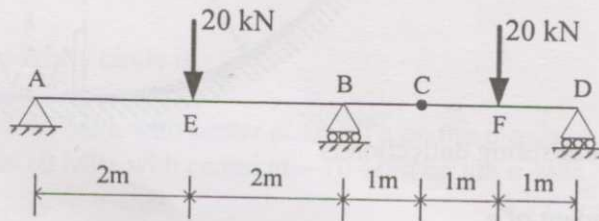

The reaction at middle support is given by

- (A) 7.5 kN
- (B) 10 kN
- (C) 20 kN
- (D) 22.5 kN

- Q.9 A bar of cross sectional area, A , is loaded as shown in the figure. The normal stress on a section $a-a$ inclined at 45° to the axis of the bar is

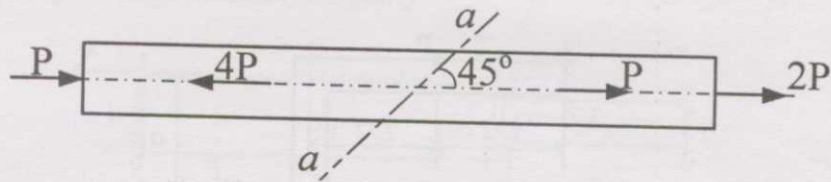

- (A) tensile with a magnitude of $3P/2A$
 (B) compressive with a magnitude of $3P/2A$
 (C) tensile with a magnitude of $P/2A$
 (D) compressive with a magnitude of $P/2A$
- Q.10 In a two-dimensional state of stress at a point, the maximum shear strain is found to be $\gamma_{\max} = 500 \mu\text{m}/\text{m}$. The sum of the normal stresses on two perpendicular planes at that point is 40 MPa. (Young's Modulus $E = 200 \text{ GPa}$; Modulus of rigidity $G = 80 \text{ GPa}$; Poisson's ratio $\nu = 0.25$). The principal stresses at the point are
- (A) $\sigma_1 = 20 \text{ MPa}$ and $\sigma_2 = 20 \text{ MPa}$ (B) $\sigma_1 = 60 \text{ MPa}$ and $\sigma_2 = -20 \text{ MPa}$
 (C) $\sigma_1 = 50 \text{ MPa}$ and $\sigma_2 = -10 \text{ MPa}$ (D) $\sigma_1 = 80 \text{ MPa}$ and $\sigma_2 = -40 \text{ MPa}$
- Q.11 A mass of 2 kg is hung by a string of length 1.5 m as shown in the figure. The mass revolves in a horizontal circular path at 50 revolutions per minute.

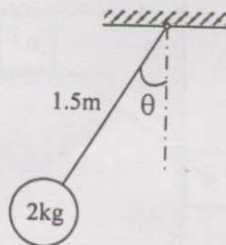

- The tension in the string in Newtons is
- (A) $25\pi/3$ (B) $25\pi^2/3$ (C) $50\pi/3$ (D) $50\pi^2/3$
- Q.12 A simply supported beam of span L is subjected to a concentrated load P at midspan. The cross-section of the beam is rectangular. The ratio of the shear stress at $1/4^{\text{th}}$ the depth of the beam to the shear stress at the center of the cross-section is
- (A) $3/8$ (B) $1/2$ (C) $3/4$ (D) 2

- Q.13 An L-shaped bar of square cross-section with sides, b , is loaded as shown in the figure.

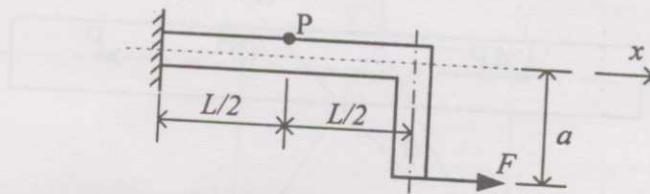

If the value of the stress component σ_{xx} at point P is zero, the distance a of the force F from the x -axis should be

- (A) b (B) $b/2$ (C) $b/3$ (D) $b/6$
- Q.14 The rigid links PQ and PR of length L each are connected to 3 sliders P, Q and R, by pin-joints as shown in the figure. The sliders, Q, and R, slide in the y -direction while the slider, P, slides in the x -direction.

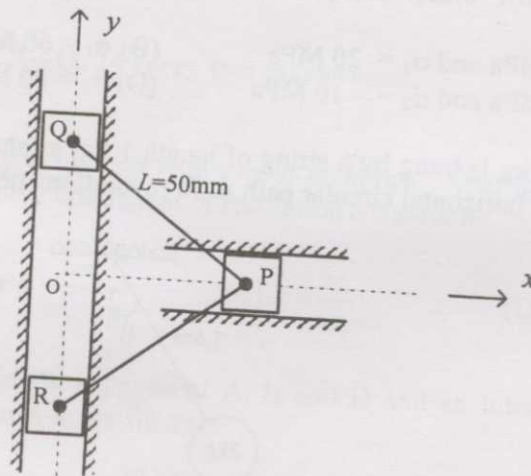

When the slider, P, is at the position $x=40$ mm, its velocity is 30 mm/s along the positive x -direction. At that instant, the velocity of slider, Q, will be

- (A) 40 mm/s along the positive y -direction
 (B) 40 mm/s along the negative y -direction
 (C) 22.5 mm/s along the positive y -direction
 (D) 22.5 mm/s along the negative y -direction
- Q.15 An open ended thin-walled straight pipe is made of a material that can carry a maximum shear stress of τ_{max} . The pipe is of diameter, d , and thickness, t . The maximum internal pressure allowable is given by (neglecting the normal stress in the radial direction)

- (A) $4\left(\frac{t}{d}\right)\tau_{max}$ (B) $2\left(\frac{t}{d}\right)\tau_{max}$ (C) $\sqrt{2}\left(\frac{t}{d}\right)\tau_{max}$ (D) $\left(\frac{t}{d}\right)\tau_{max}$

- Q.16 A stepped shaft PQR is fixed at both the ends as shown in the figure. A torque T is applied at point Q. The polar moments of inertia of the shafts PQ and QR are J_1 and J_2 respectively. G is the modulus of rigidity.

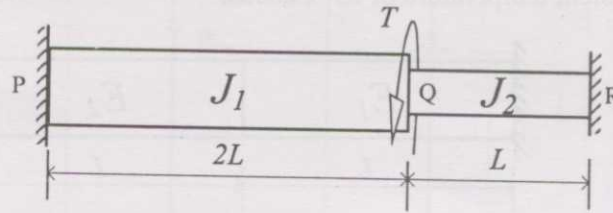

The angle of twist at point Q due to torque, T , is given by (in radians)

- (A) $\frac{2}{J_1} \left(\frac{TL}{G} \right)$ (B) $\frac{1}{J_2} \left(\frac{TL}{G} \right)$ (C) $\left(\frac{2}{J_1} + \frac{1}{J_2} \right) \left(\frac{TL}{G} \right)$ (D) $\left(\frac{2}{J_1 + 2J_2} \right) \left(\frac{TL}{G} \right)$
- Q.17 Group I contains beams with different types of supports and loading conditions. The beams have the same flexural rigidity EI and span L . Group II contains the maximum deflections. Match the beam from Group I with the maximum deflection given in Group II.

	Group I	Group II
P.		1. $\frac{1}{3} \left(\frac{FL^3}{EI} \right)$
Q.		2. $\frac{1}{8} \left(\frac{FL^3}{EI} \right)$
R.		3. $\frac{1}{48} \left(\frac{FL^3}{EI} \right)$
S.		4. $\frac{5}{384} \left(\frac{FL^3}{EI} \right)$

- (A) P-3, Q-4, R-1, S-2
(C) P-4, Q-3, R-1, S-2

- (B) P-3, Q-2, R-1, S-4
(D) P-3, Q-4, R-2, S-1

- Q.18 Two bars of different Young's moduli, E_1 and E_2 , but with the same cross sectional area, A , and coefficient of thermal expansion, α , are attached together at one end and fixed at the other as shown in the figure. The construction of this setup was carried out at an ambient temperature of 25° Celsius.

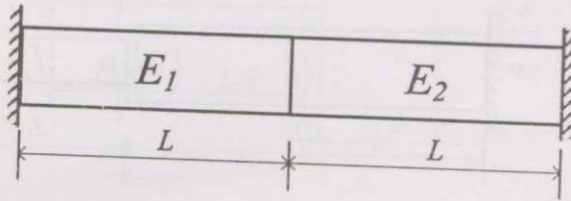

The stress in the bars when the temperature is uniformly increased by 10° Celsius is

- (A) $\sigma = 10\alpha(E_1 + E_2)$ (B) $\sigma = 20\alpha(E_1 + E_2)$
 (C) $\sigma = 20\alpha\left(\frac{E_1 E_2}{E_1 + E_2}\right)$ (D) $\sigma = 10\alpha\left(\frac{E_1 E_2}{E_1 + E_2}\right)$

- Q.19 A cylinder of radius r and mass m is placed with no initial velocity on a conveyor belt as shown in the figure. There is a frictional contact between the cylinder and the belt at B. A vertical stopper with a smooth surface prevents the cylinder from rolling away. (I , is the moment of inertia of the cylinder; α , is the angular acceleration of the cylinder; μ , is the coefficient of friction between the cylinder and the belt and, g , is the acceleration due to gravity)

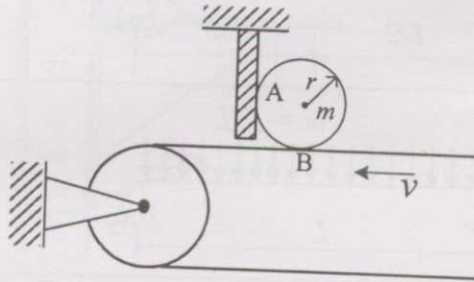

The valid free-body diagram of the cylinder just after placing it on the belt (that shows inertial forces also) is

- (A) (B)
- (C) (D)

- Q.20 The figure below shows 4 long columns with different support conditions but the same flexural rigidity EI . Let P , Q , R , and S be the values of their critical buckling load as shown below the respective columns.

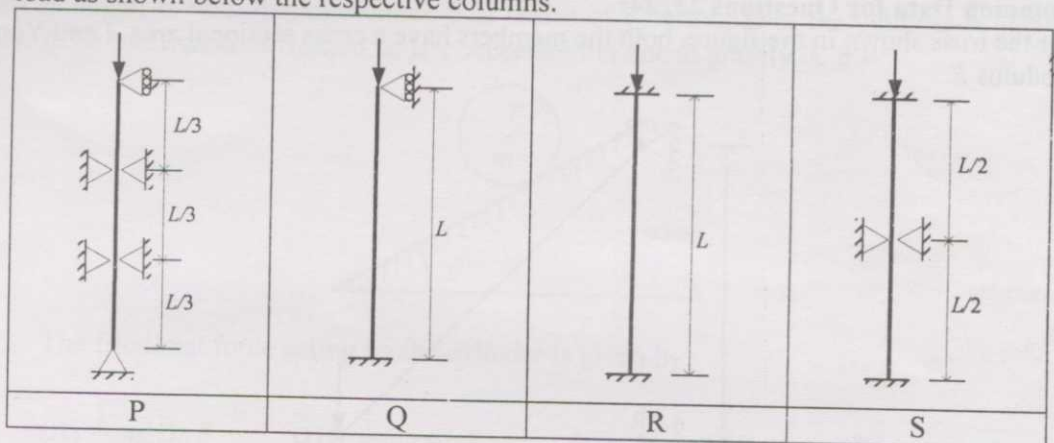

P , Q , R and S can be arranged in increasing order as

- (A) Q, S, R, P (B) Q, P, R, S (C) Q, R, P, S (D) Q, R, S, P
- Q.21 A circular shaft of diameter, d , is fixed at one end and subjected to an axial force, P , and a torque, T , at the other end. The torque, T , is equal to $Pd/8$. The tensile yield stress of the shaft material is σ_y . A point on the surface of the shaft will yield according to the Tresca yield criterion if P is equal to

- (A) $\sigma_y \left(\frac{\pi d^2}{4\sqrt{2}} \right)$ (B) $\sigma_y \left(\frac{\pi d^2}{4} \right)$ (C) $\sigma_y (d^2)$ (D) $\sigma_y (\pi d^2)$

- Q.22 A single degree freedom system consisting of 2 springs and a mass is shown in the figure.

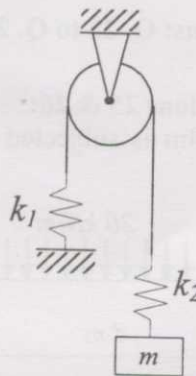

The natural frequency of the system in radians/sec is given by

- (A) $\sqrt{\frac{k_1}{m}}$ (B) $\sqrt{\frac{k_2}{m}}$ (C) $\sqrt{\frac{k_1 k_2}{(k_1 + k_2)m}}$ (D) $\sqrt{\frac{k_1 + k_2}{m}}$

Common Data Questions

Common Data for Questions 23, 24:

For the truss shown in the figure, both the members have a cross sectional area A and Young's modulus E .

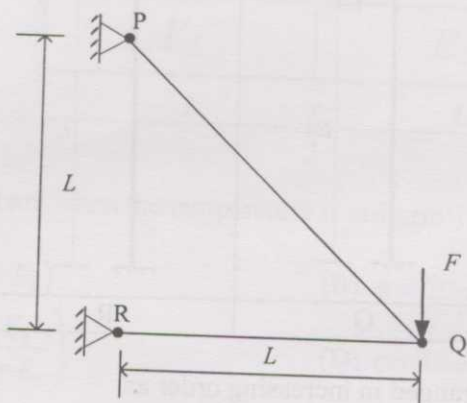

Q.23 The vertical deflection at point Q is

- (A) $\left(\frac{FL}{AE}\right)$ (B) $2\left(\frac{FL}{AE}\right)$ (C) $2\sqrt{2}\left(\frac{FL}{AE}\right)$ (D) $(1+2\sqrt{2})\left(\frac{FL}{AE}\right)$

Q.24 The horizontal deflection at point Q is

- (A) $\frac{1}{2}\left(\frac{FL}{AE}\right)$ (B) $\frac{3}{4}\left(\frac{FL}{AE}\right)$ (C) $\left(\frac{FL}{AE}\right)$ (D) $\frac{3}{2}\left(\frac{FL}{AE}\right)$

Linked Answer Questions: Q. 25 to Q. 28 carry two marks each.

Statement for Linked Answer Questions 25 & 26:

A propped cantilever beam of span 4m is subjected to a uniformly distributed load of 20 kN/m as shown in the figure.

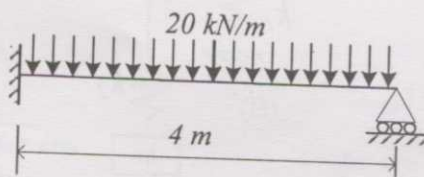

Q.25 The reaction at the roller support is

- (A) 20 kN (B) 30 kN (C) 40 kN (D) 80 kN

Q.26 The maximum bending moment in the beam is

- (A) 7.5 kNm (B) 22.5 kNm (C) 67.5 kNm (D) 97.5 kNm

Statement for Linked Answer Questions 27 & 28:

A cylinder of mass, m , and radius, r , is rolling without slipping down an inclined plane that makes an angle, θ , with the horizontal. The radius of gyration, k , of the cylinder is half the radius. (The coefficient of friction is, μ ; Acceleration due to gravity is, g)

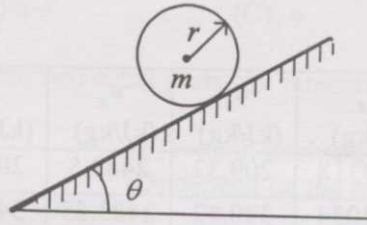

Q.27 The frictional force acting on the cylinder is given by

- (A) $\frac{1}{5}mg \sin \theta$ (B) $\frac{1}{2}mg \sin \theta$ (C) $\mu mg \sin \theta$ (D) $mg \sin \theta$

Q.28 The angular acceleration of the cylinder is given by

- (A) $4\left(\frac{g \sin \theta}{r}\right)$ (B) $2\left(\frac{g \sin \theta}{r}\right)$ (C) $4\mu\left(\frac{g \sin \theta}{r}\right)$ (D) $\frac{4}{5}\left(\frac{g \sin \theta}{r}\right)$

END OF THE SECTION

G: Thermodynamics

Useful data:

Universal gas constant: $R_u = 8.314 \text{ kJ/kmol.K}$

For water (saturated):

P (kPa)	T ^{Sat} (°C)	v_f (m ³ /kg)	v_g (m ³ /kg)	u_f (kJ/kg)	u_g (kJ/kg)	h_f (kJ/kg)	h_g (kJ/kg)	s_f (kJ/kg.K)	s_g (kJ/kg.K)
12.349	50	0.001012	12.0318	209.32	2443.5	209.33	2592.1	0.7038	8.0763
50	81.33	0.001030	3.24034	340.42	2483.85	340.47	2645.87	1.0910	7.5939
1000	179.91	0.001127	0.19444	761.67	2583.64	762.79	2778.08	2.1386	6.5864
10000	311.06	0.001452	0.01802	1393.04	2544.4	1407.56	2724.7	3.3596	5.6141
22090	374.14	0.003155	0.003155	2029.6	2029.6	2099.3	2099.3	4.4298	4.4298

For water (superheated)

P (kPa)	T (°C)	v (m ³ /kg)	u (kJ/kg)	h (kJ/kg)	s (kJ/kg.K)
1000	400	0.3066	2957.3	3263.9	7.4651
4000	450	0.08003	3010.13	3330.23	6.9362

Q. 1 – Q. 6 carry one mark each.

- Q.1 The specific gravity of ice at 0°C is
- (A) greater than unity (B) less than unity
(C) equal to unity (D) cannot say; insufficient information
- Q.2 Which one of the following equations is correct?
- (A) $v = (1-x)v_f + xv_g$ (B) $v = v_f + v_g$
(C) $v = xv_f + (1-x)v_g$ (D) $v = x(v_f + v_g)$
- Q.3 In an ideal vapour compression refrigeration system, the process in the condenser is
- (A) heat addition at constant pressure
(B) heat removal at constant volume
(C) heat removal at constant pressure
(D) heat addition at constant volume
- Q.4 One kilogram of a perfect gas at 15°C and 100 kPa is heated to 45°C by (i) a constant pressure process and (ii) a constant volume process. c_p of the gas = 1.042 kJ/kg.K and $R = 0.2968 \text{ kJ/kg.K}$. Heat added in the constant pressure (Q_p) and constant volume (Q_v) processes are
- (A) $Q_p = 31.26 \text{ kJ}$, $Q_v = 22.35 \text{ kJ}$ (B) $Q_p = 22.35 \text{ kJ}$, $Q_v = 31.26 \text{ kJ}$
(C) $Q_p = 31.26 \text{ kJ}$, $Q_v = 31.26 \text{ kJ}$ (D) $Q_p = 22.35 \text{ kJ}$, $Q_v = 0 \text{ kJ}$

Q.5 A system is capable of exchanging energy with its surroundings in the form of n reversible work modes. The number of independent variables that completely specify the state of the system is

- (A) $n-2$ (B) $n-1$ (C) n (D) $n+1$

Q.6 A system is partitioned into two equal parts. An intensive property of each part will

- (A) become half (B) remain unchanged
(C) double (D) depend on the nature of the intensive property

Q. 7 – Q. 24 carry two marks each.

Q.7 The polytropic index n of an isochoric process is equal to

- (A) zero (B) one (C) minus one (D) infinity

Q.8 Two systems A and B, possessing the same internal energy, contain saturated liquid-vapour mixture of water at 1 MPa. The maximum value of the ratio of their masses is

- (A) 1.4 (B) 2.4 (C) 3.4 (D) 4.4

Q.9 The net work output for the cycle 1-2-3-4-5-6-1 shown in figure F9 is

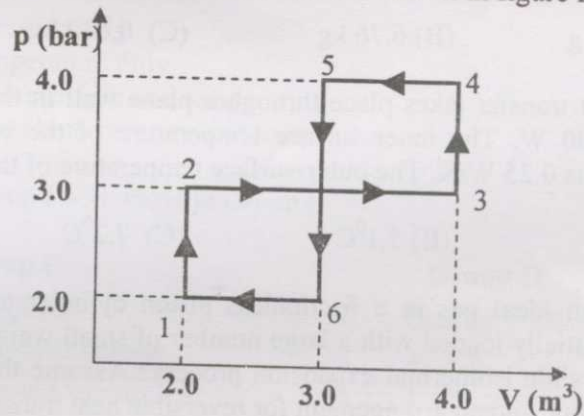

Fig. F9

- (A) 200 kJ (B) 1200 kJ (C) 0 kJ (D) 1000 kJ

Q.10 Steam enters an adiabatic turbine steadily at 450°C and 4.0 MPa and leaves at 50 kPa. The minimum possible dryness fraction of the steam at the turbine exit is approximately

- (A) 85 % (B) 90 % (C) 95 % (D) 97 %

- Q.11 A rigid vessel contains saturated liquid-vapour mixture of water at 10 MPa. On being heated, the mixture reaches the critical point. The initial quality of the mixture is approximately
- (A) 1 % (B) 5 %
(C) 10 % (D) 15 %
- Q.12 A Diesel engine has a compression ratio of 16 and cut-off takes place at 8% of stroke. Assuming an air-standard cycle, the cut-off ratio is
- (A) 1.20 (B) 2.20 (C) 3.20 (D) 4.20
- Q.13 In a Brayton cycle, if ΔT_e is the temperature change during the expansion process, and ΔT_c is the change in temperature during the compression process, then
- (A) $|\Delta T_e| - |\Delta T_c| > 0$ (B) $|\Delta T_e| - |\Delta T_c| < 0$
(C) $|\Delta T_e| - |\Delta T_c| = 0$ (D) $|\Delta T_e| - |\Delta T_c|$ solely depends on the compression ratio
- Q.14 A rigid tank is connected through a valve to steam mains supplying steam at 1 MPa, 400°C . Heat is transferred from the tank to the surroundings, and the valve is closed when the total amount of cooling is 2000 kJ. The energy contained in the tank is the same before and after the process. Neglecting potential and kinetic energy changes, the mass of the steam that enters the tank is
- (A) 0.676 kg (B) 6.76 kg (C) 0.612 kg (D) 6.12 kg
- Q.15 Steady heat transfer takes place through a plane wall in the outward direction at the rate of 1500 W. The inner surface temperature of the wall is 27°C . The entropy generation is 0.25 W/K. The outer-surface temperature of the wall is
- (A) 2.7°C (B) 5.1°C (C) 7.2°C (D) 12.7°C
- Q.16 Consider an ideal gas in a frictionless piston cylinder assembly. The weightless piston is initially loaded with a large number of small weights. How would you carry out a reversible isothermal expansion process? Assume that a large number of very small weights, and an arrangement for reversible heat transfer are available.
- (A) without adding or removing weights on the piston, transfer heat to the system
(B) without adding or removing weights on the piston, transfer heat from the system
(C) adding weights on the piston, transfer heat to the system.
(D) removing weights from the piston, transfer heat to the system.
- Q.17 Consider an isentropic process undergone by an incompressible liquid. The change in temperature experienced by the liquid is $\Delta T = T_2 - T_1$. Which one of the following is correct?
- (A) $\Delta T = 0$ (B) $\Delta T > 0$
(C) $\Delta T < 0$ (D) ΔT depends on the liquid under consideration

Q.18 In the following T-p diagram, an inversion curve is shown. Which one of the following is correct?

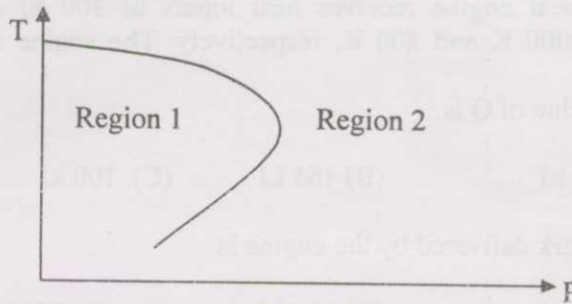

- (A) Region 1: Cooling, Region 2: Cooling
- (B) Region 1: Heating, Region 2: Cooling
- (C) Region 1: Cooling, Region 2: Heating
- (D) Region 1: Heating, Region 2: Heating

Q.19 A large furnace can supply heat at a temperature of 1200 K at a steady rate of 3200 kW. The ambient temperature is 27°C. The availability of this energy is

- (A) 0 kW
- (B) 800 kW
- (C) 1200 kW
- (D) 2400 kW

Q.20 For a system containing an ideal gas, the difference between Gibbs function and Helmholtz function

- (A) depends on pressure only
- (B) depends on temperature only
- (C) depends on both pressure and temperature
- (D) is independent of both pressure and temperature

Q.21 Match items in Group I with those in Group II

Group I		Group II	
P	Critical point	1	Quality = 1.0
Q	Dry saturated vapour	2	$v_f = v_g$
R	Superheated vapour	3	$T > T_{sat}$
		4	$T < T_{sat}$

- (A) P-1,Q-2,R-3
- (B) P-1,Q-3,R-2
- (C) P-2,Q-1,R-3
- (D) P-2,Q-1,R-4

Q.22 Consider steady flow of air ($c_p = 1005 \text{ J/kg.K}$) in an adiabatic passage. Air enters the passage at 100 kPa, 500 K at a velocity of 150 m/s and exits the passage at 510 K. Assume air to be an ideal gas and neglect gravitational effects. The passage is a

- (A) diffuser, and the velocity at the exit is approximately 49 m/s
- (B) diffuser, and the velocity at the exit is approximately 79 m/s
- (C) nozzle, and the velocity at the exit is approximately 179 m/s
- (D) nozzle, and the velocity at the exit is approximately 249 m/s

Common Data Questions

Common Data for Questions 23, 24:

A reversible heat engine receives heat inputs of 300 kJ and 200 kJ from two thermal reservoirs at 1000 K and 800 K, respectively. The engine rejects heat Q to a reservoir at 300 K.

Q.23 The value of Q is

- (A) 65 kJ (B) 165 kJ (C) 100 kJ (D) 265 kJ

Q.24 The work delivered by the engine is

- (A) 35 kJ (B) 135 kJ (C) 235 kJ (D) 335 kJ

Linked Answer Questions: Q. 25 to Q. 28 carry two marks each.

Statement for Linked Answer Questions 25 & 26:

A piston-cylinder arrangement contains an ideal gas mixture of 1 kg Nitrogen ($M = 28 \text{ kg/kmol}$, $\gamma = 1.4$) and 2 kg of Argon ($M = 40 \text{ kg/kmol}$, $\gamma = 1.667$), at 100 kPa, 300 K. The gas expands at constant pressure until the volume increases by 1 m^3 .

Q.25 The initial volume of the gas mixture is approximately

- (A) 2.14 m^3 (B) 1.07 m^3 (C) 4.28 m^3 (D) 3.21 m^3

Q.26 The heat added is approximately

- (A) 145.81 kJ (B) 97.21 kJ (C) 291.65 kJ (D) 218.72 kJ

Statement for Linked Answer Questions 27 & 28:

A rigid tank contains a mixture of 0.2 kg of saturated water vapour and 2 kg of air ($M = 29 \text{ kg/kmol}$) at a temperature of 50°C .

Q.27 The volume of the mixture is approximately

- (A) 1.42 m^3 (B) 2.41 m^3 (C) 4.12 m^3 (D) 0.412 m^3

Q.28 The pressure of the tank is approximately

- (A) 89.4 kPa (B) 98.4 kPa (C) 48.9 kPa (D) 148.9 kPa

END OF THE SECTION