

Subject: CHEMISTRY, MATHEMATICS & PHYSICS

Paper Name: JEE\_ Main\_ Sample Paper - V

Duration: 3 hours

Maximum Marks: 360

PART – A - CHEMISTRY

1)

Ans: a

Exp: A in the acidic medium, appears as  $SN_1$  type product as  $3^\circ$  carbo-cation is more stable that's why

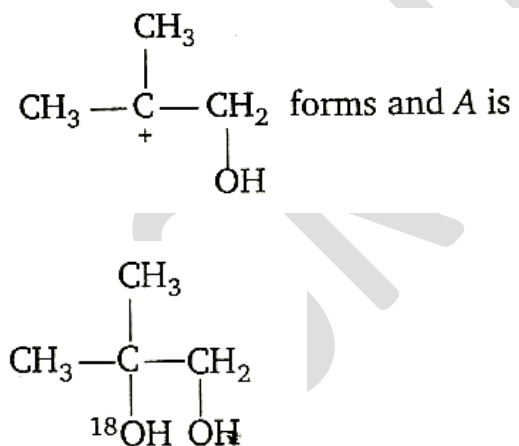

AskIITians

B – 147,1st Floor, Sec-6, NOIDA, UP-201301,  
Website: [www.askiitians.com](http://www.askiitians.com), Email: [info@askiitians.com](mailto:info@askiitians.com)  
Tel: 1800 2000 838 (Toll free)

B appears as  $S_N2$  type product as  $1^\circ$  is less sterically hindered that's why

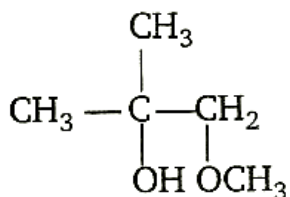
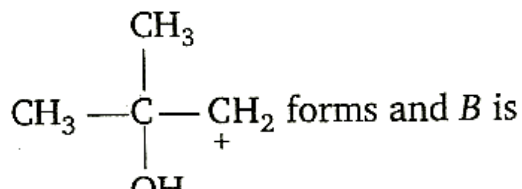

2)

Ans: a

Exp: Theoretically the pH should be negative. But practically it is not possible because effective concentration of  $\text{H}_3\text{O}^+$  ions will not be equal to 10M in such a concentrated solution. Hence, pH is approximately zero.

3)

Ans: c

Exp: Bond order of various species

$$N_2 = 3; N_2^+ = 2.5; N_2^- = 2.5; N_2^{2-} = 2;$$

Bond order  $\propto$  bond energy.

Hence, order is  $N_2 > N_2^+ = N_2^- > N_2^{2-}$ .

4)

Ans: a

Exp:  $CH_4$  has a regular tetrahedral geometry hence net dipole moment,  $\mu_R = 0$ .

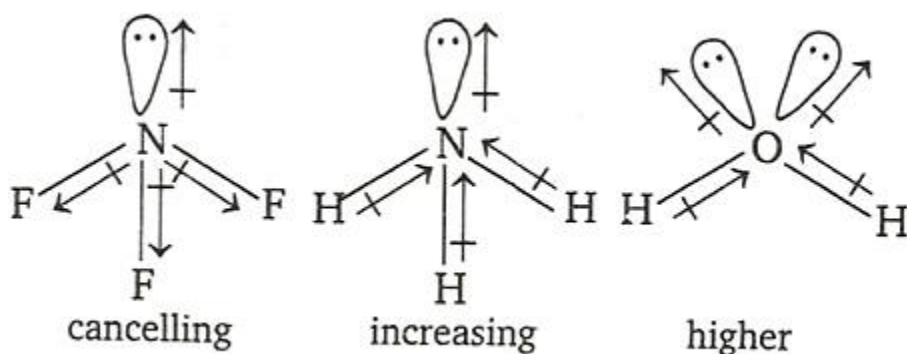

5)

Ans: c

Exp:  $NH_3 + H_2O \rightleftharpoons NH_4^+ + OH^-$

$$K_b = \frac{[NH_4^+][OH^-]}{[NH_3]}$$

$$1.8 \times 10^{-5} = \frac{x^2}{0.10}$$

$$x^2 = 1.8 \times 10^{-6}$$

$$x = 1.35 \times 10^{-3} = [OH^-]$$

AskIITians

B - 147, 1st Floor, Sec-6, NOIDA, UP-201301,  
Website: [www.askiitians.com](http://www.askiitians.com), Email: [info@askiitians.com](mailto:info@askiitians.com)  
Tel: 1800 2000 838 (Toll free)

$$\text{pOH} = 2.87$$

$$\text{pH} = 11.13$$

6)

Ans: a

Exp: Gluconic acid

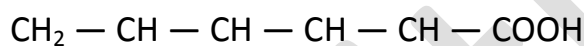

7)

Ans: b

Exp:  $X(g) \rightarrow X^+(g) + e^-$

If I is ionisation energy, then

$$\therefore \frac{N_0}{2}(I) = E_1 \quad \therefore I = \frac{2E_1}{N_0}$$

If E is electron affinity, then

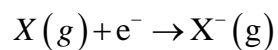

$$\frac{N_0}{2}(E) = E_2$$

$$\therefore E = \frac{2E_2}{N_0}$$

8)

Ans: b

Exp:  $H^+ e^- \Rightarrow (1/2)H_2(g)$

$$E_1 = 0 - .0591 \log \frac{1}{(H^+)_1}$$

$$E_1 = 0 + .0591 \log [H^+]_1 = -.0591 pH_1$$

$$E_2 = -.0591 pH_2$$

$$pH_1 = pK_a + \log \frac{\text{salt}}{\text{acid}}; pH_1 = pK_a + \log \frac{a}{b} \dots\dots\dots(1)$$

$$pH_2 = pK_a + \log \frac{b}{a}; pH_2 = pK_a - \log \frac{a}{b} \dots\dots\dots(2)$$

$$\text{Add (1) \& (2) } pH_1 + pH_2 = 2pK_a$$

$$2pK_a = - \frac{E_1}{.0591} - \frac{E_2}{.0591}; pK_a = - \left[ \frac{E_1 + E_2}{0.118} \right]$$

9)

Ans: b

Exp: A square planar complex is formed by the hybridization of s, P<sub>x</sub>, P<sub>y</sub> and d<sub>x<sup>2</sup>-y<sup>2</sup></sub>

atomic orbitals.

10)

Ans: b

Exp: For spontaneous dissolution, dissolution should be exothermic. That's why the amount of energy released in solvation must be higher than the energy, which is required to break down ionic crystals into respective ions.

11)

Ans: b

Exp:  $E_{\text{cell}}$  is not the intensive property, cannot be additive, instead

$\Delta G$  is extensive property

$$\Delta G_3 = \Delta G_1 + \Delta G_2$$

$$n_3 E_3 = - (n_1 E_1 - n_2 E_2) / n_3$$

$$E_3 = (n_1 E_1 + n_2 E_2) / n_3$$

12)

Ans: a

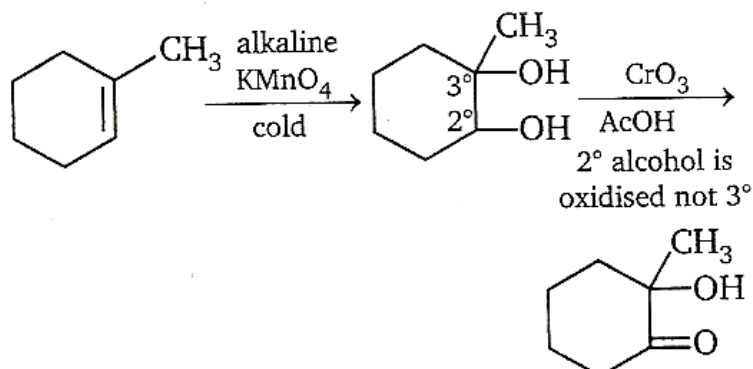

Exp:

13)

Ans: d

Exp: According to Boyle's law  $V \propto (1/P)$  for a given mass of a gas at constant temperature. i.e.  $PV = \text{constant}$ . Thus law can be verified by plotting

- (a) P vs  $(1/V)$  when a straight line passing through the origin is obtained.
- (b)  $PV$  vs P when a straight line parallel to the x – axis is obtained.
- (c) V vs P when branch of hyperbola in the first quadrant is obtained.

14)

Ans: a

Exp: Their conjugate acids are  $\text{H} - \text{OH}$ ,  $\text{NH}_3$ ,  $\text{H} - \text{C} \equiv \text{C} - \text{H}$  and  $\text{CH}_4$ . The acidic characters of these acids follow:

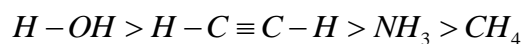

A strong acid has weak conjugate base. Hence the strength of bases will be  $CH_3^- > NH_2^- > H-C \equiv C^- > OH^-$

15)

Ans: c

Exp: By conventional method:  $H_2^+ S^x O_5^{-2}$

$$2x(+1) + x + 5x(-2) = 0 \quad \text{or} \quad x = 8$$

Thus oxidation of S is 8 which is wrong because maximum oxidation number of S cannot be more than +6, since it has only 6 electrons in its valence shell. This unusual value of oxidation number for the S is due to reason that the two of the oxygen atoms in  $H_2SO_5$  are joined by a peroxide linkage. By chemical bonding method: The structure of  $H_2SO_5$  is

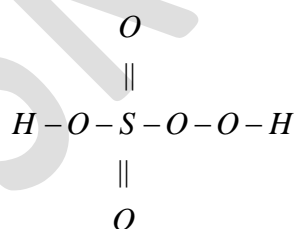

Oxidation number of S will be

$$\begin{aligned} 2x(+1) + x + 2x(-1) + 3x(-2) &= 0 \\ (\text{for } O-O) \\ = 2 + x - 6 - 2 &= 0 \quad \text{or} \quad x = +6 \end{aligned}$$

AskIITians

B - 147, 1st Floor, Sec-6, NOIDA, UP-201301,  
Website: [www.askiitians.com](http://www.askiitians.com), Email: [info@askiitians.com](mailto:info@askiitians.com)  
Tel: 1800 2000 838 (Toll free)



16)

Ans: a

Exp: Thermal stability decreases as the basic character of metal hydroxides decreases. This can also be explained on the basis of lattice energy increases down the group because of decrease in the size of cation.

17)

Ans: c

Exp: Only A and C are anomers.

A and B }  
B and C } are structural isomers.

18)

Ans: d

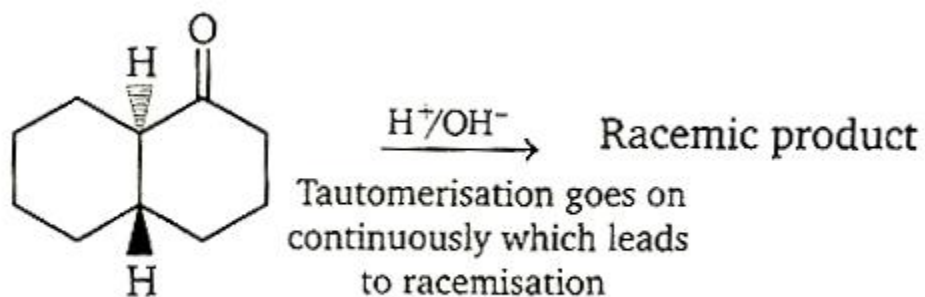

Exp:



### Cu-quinoline

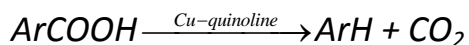

Cuprous salts of aromatic acids, actually undergoes decarboxylation. However, two other methods can be used with certain substrates.

Method 1: Salt of acid,  $\text{ArCOO}^-$  is heated (SEI)

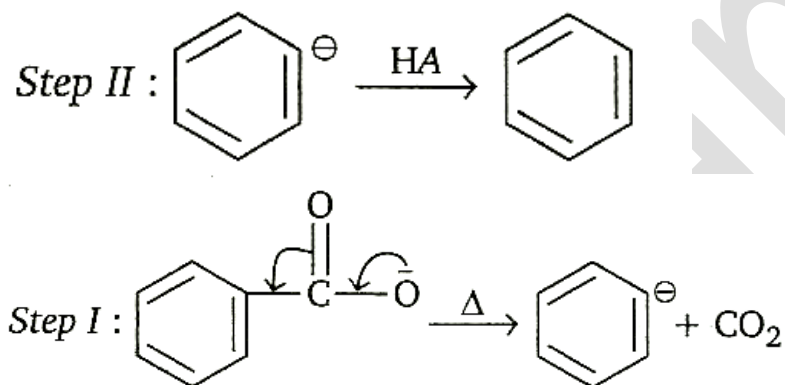

Method II: Carboxylic acid is heated with a strong acid, often sulphuric acid.

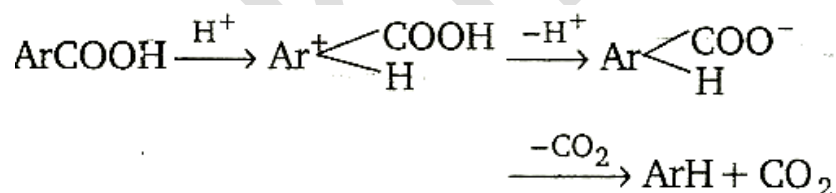

Decarboxylation takes place by the arenium ion mechanism, with  $\text{H}^+$  electrophile. Evidently, the order of electro fugal ability is  $\text{CO}_2 > \text{H}^+ > \text{COOH}^+$ . Rearrangements are also known to take place. For example, when the phthalate ion is heated with catalytic amount of cadmium, the terephthalate ion is produced.

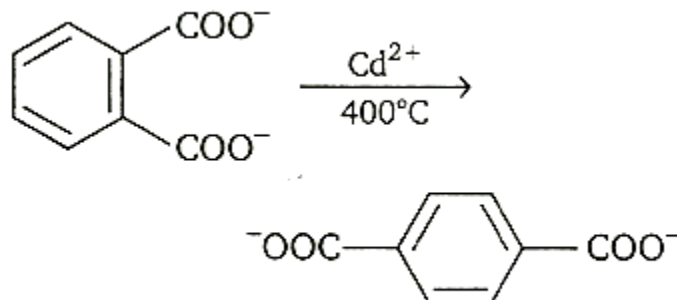

*In a similar process, potassium benzoate heated with cadmium salts disproportionate. The rearrangement is named as 'Henkel rearrangement'.*

20)

Ans: b

Exp: Greater the stability of

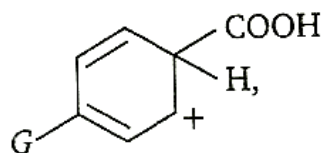

Greater the ease of decarboxylation

21)

Ans: c

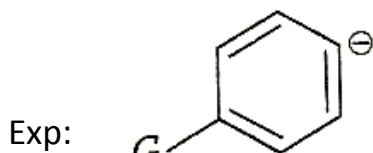

is stabilised by inductive effect only. Greater the stability of carbanion, greater is the ease of decarboxylation.

22)

Ans: b

Exp: Disproportionate takes place.

23)

Ans: b

Exp: Rate of a reaction is always determined by the slowest step. Hence, rate determining step is:

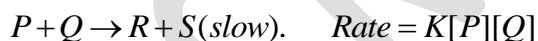

Below given 3 questions are based on the Paragraph given. First read the paragraph and then answer the questions:-

### Paragraph

*Properties, whose values depend only the concentration of solute particles in solution and not on the identity of the solute, are called colligative properties. There may be change in number of moles of solute due to*

ionization or association hence these properties are also affected. Number of moles of the product is related to degree of ionization or association by Vant Hoff factor 'i'.

Given by  $i = [1 + (n-1)\alpha]$  for dissociation and

$$i = \left[ 1 + \left( \frac{1}{n} - 1 \right) \alpha \right] \text{ for association}$$

where  $n$  is the no. of products (ions or molecules) obtained per mole of the reactant. A dilute solution contains 't' moles of solute  $X$  in 1kg of solvent with molal elevation constant  $K_b$ . The solute dimerises in the solution according to the following equation. The degree of association is  $\alpha$ .

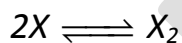

24)

Ans: b

Exp:  $i = 1 + \left( \frac{1}{n} - 1 \right) \alpha$

$$i = 1 - \frac{\alpha}{2}$$

25)

Ans: c

Exp: During dissociation,  $\Delta P_{\text{obs}} < \Delta P_{\text{act}}$ ;

$$\Delta T_{\text{obs}} < \Delta T_{\text{actual}}; \Delta T_{\text{f obs}} < \Delta T_{\text{f actual}}$$

26)

Ans: b

Exp:  $K = \frac{[x]}{[x]^2}$

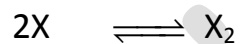

$$t \quad \quad 0$$

$$t - t\alpha \quad \quad \frac{t\alpha}{2}$$

$$\Rightarrow K = \frac{\frac{t\alpha}{2}}{(t - t\alpha)^2}$$

$$= \frac{1}{2t} \times \frac{\alpha}{(1 - \alpha)^2}$$

$$\frac{1}{2t} \times \frac{\frac{2(K_{\theta}t - \Delta T_b)}{K_{\theta}t}}{\left(1 - \frac{2(K_{\theta}t - \Delta T_b)}{K_{\theta}t}\right)^2}$$

27)

Ans: b

Exp:  $\text{NH}_4\text{HS(s)} \rightleftharpoons \text{NH}_3\text{(g)} + \text{H}_2\text{S(g)}$ , if  $K_p = 64 \text{ atm}^2$

$$K_p = P_{\text{NH}_3} \times P_{\text{H}_2\text{S}}$$

$$64 = p^2 \quad [P_{\text{NH}_3} = P_{\text{H}_2\text{S}} = P \text{ atm}]$$

$$P = 8 \text{ atm}$$

So, equilibrium pressure =  $8 + 8 = 16 \text{ atm}$ .

28)

Ans: b

Exp: Sulphur possess the maximum tendency to catenation due to highest bond strength of S-S bond. The tendency for catenation decreases as we down the group from S to Te. Oxygen posses this property to less extent.

29)

Ans: a



Exp: The members of oxygen family form MF<sub>4</sub> type tetrafluorides (where M = O, S, Se, Te), in which the central atom is sp<sup>3</sup> hybridised with a irregular tetrahedral geometry due to presence of one lone pair of electrons.

30)

Ans: b

Exp:

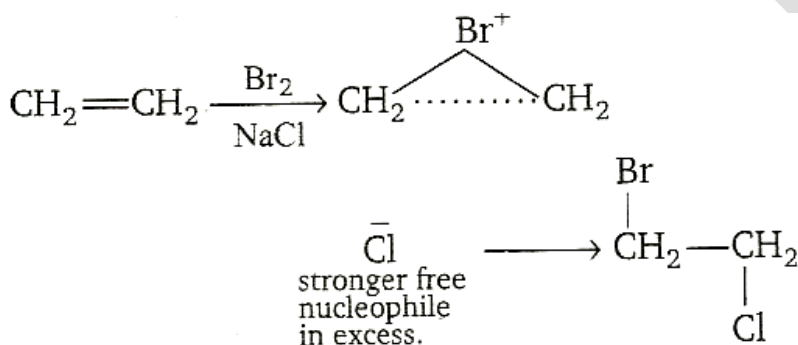

**PART – B - PHYSICS**

31)

Ans: d

Exp: Velocity of particle

$$\frac{dy}{dt} = a \cos \left\{ \frac{2\pi}{\lambda} (vt - x) \right\} \frac{2\pi v}{\lambda} \dots\dots\dots(1)$$

Slope of curve,

$$\frac{dy}{dx} = a \cos \left\{ \frac{2\pi}{\lambda} (vt - x) \right\} \left\{ \frac{-2\pi}{\lambda} \right\} \dots\dots\dots(2)$$

By equation (1) and (2)

$$\frac{dy/dt}{dy/dx} = -v \therefore \frac{dy}{dt} = -v \frac{dy}{dx}$$

32)

Ans: c

Exp: Let  $m_A$  and  $m_B$  be the mass of blocks A and B respectively.

As the force  $F$  increases from 0 to  $\mu_s m_A g$ , the frictional force  $f$  on block A is such that  $f = F$ . When  $F = \mu_s m_A g$ , the frictional force  $f$  attains maximum value  $f = \mu_s mg$ .

As  $F$  is further increased to  $\mu_s (m_A + m_B)g$ , the block A does not move. In this duration frictional force on block A remains constant at  $\mu_s m_A g$ ,

Hence C is correct choice.

33)

Ans: d

Exp: Limiting friction between A and B = 60N

Limiting friction between B and C = 90N

Limiting friction between C and ground = 50N

Since limiting friction is least between C and ground, slipping will occur at first between C and ground. This will occur when  $F = 50\text{N}$ .

34)

Ans: d

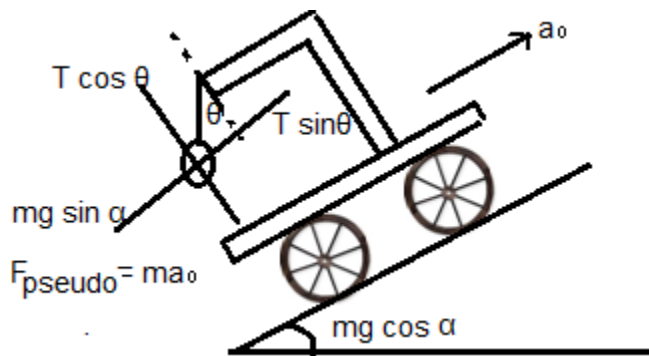

Exp:

$$T \sin \theta = ma_0 + mg \sin \alpha$$

$$T \cos \theta = mg \cos \alpha \quad \tan \theta = \frac{a_0 + g \sin \alpha}{g \cos \alpha}$$

35)

Ans: d

Exp: Mass of hanging portion is  $M/3$  (one-third) and centre of mass C, is at a distance  $h = L/6$  below the table top.

Therefore, the required work done is

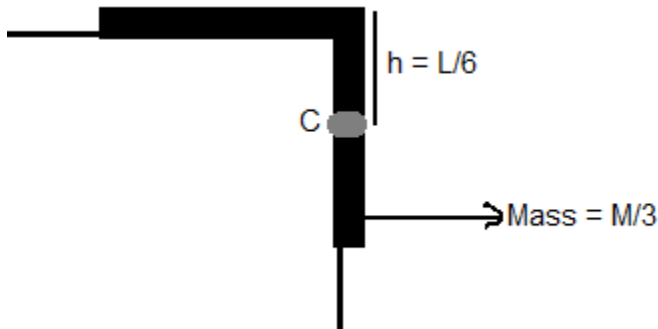

$$W = mgh = (M/3) (g) (L/6) = MgL/18$$

36)

Ans: b

$$m = m_0 e^{-\lambda t}$$

$$\therefore \left( \frac{-dm}{dt} \right) = m_0 \lambda e^{-\lambda t}$$

$$\text{Now thrust force } F = u \left( -\frac{dm}{dt} \right)$$

Exp: or  $m \left( \frac{dv}{dt} \right) = u m_0 \lambda e^{-\lambda t}$

or  $(m_0 e^{-\lambda t}) \frac{dv}{dt} = u m_0 \lambda e^{-\lambda t}$

or  $dv = u \lambda dt$

or  $\int_0^v dt = u \lambda \int_0^t dt$

or  $v = u \lambda t$

37)

Ans: c

Exp: Let  $v$  be the linear velocity of centre of mass of the spherical body and  $\omega$ , its angular velocity about centre of mass. Then

$$\omega = \frac{v}{2R}$$

KE of spherical body

$$K_1 = \frac{1}{2}mv^2 + \frac{1}{2}I\omega^2$$

or

$$K_1 = \frac{1}{2}mv^2 + \frac{1}{2}(2mR^2)\left(\frac{v^2}{4R^2}\right)$$

$$= \frac{3}{4}mv^2 \quad \dots\dots(1)$$

Speed of the block will be

$$v' = (\omega)(3R) = 3R\omega = (3R)\left(\frac{v}{2R}\right) = \frac{3}{2}v$$

$\therefore$  KE of block  $K_2 = \frac{1}{2}mv'^2$

$$= \frac{1}{2}m\left(\frac{3}{2}v\right)^2 = \frac{9}{8}mv^2 \quad \dots\dots(2)$$

From Eqs. (1) and (2)

$$\frac{K_1}{K_2} = \frac{2}{3}$$

38)

Ans: b

Exp: The rod will rotate about point A angular acceleration:

$$\alpha = \frac{\tau}{I} = \frac{Fx}{\frac{ml^2}{3}} = \frac{3Fx}{ml^2}$$

$$\therefore a = \frac{\alpha}{2} = \frac{3Fx}{2ml} \quad \text{or} \quad \alpha \propto x$$

i.e., a-x graph is a straight line passing through origin.

39)

Ans: b

Exp:

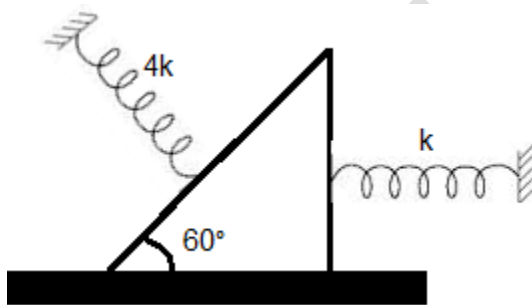

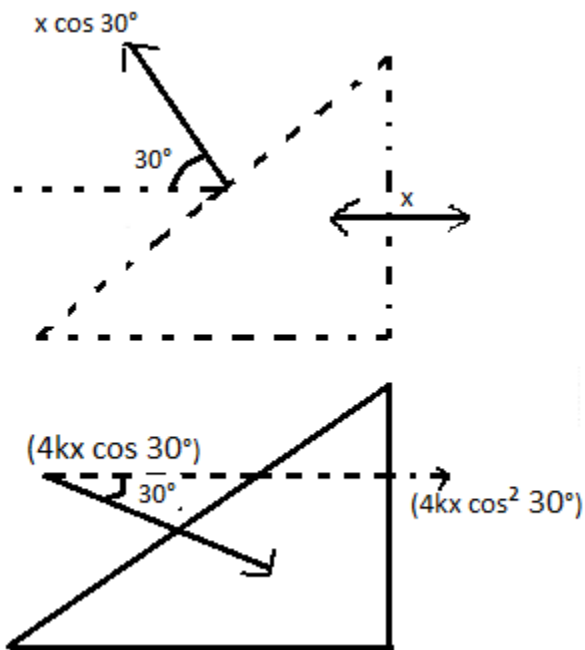

$$F = 4kx \cos^2 30^\circ$$

$$T = \frac{2\pi}{\sqrt{3k}} \sqrt{M}$$

$$\Rightarrow t_1 = \frac{T_1}{2} = \frac{\pi}{\sqrt{3k}} \sqrt{M}$$

$$\Rightarrow t_2 = \frac{T_2}{2} = \pi \sqrt{\frac{M}{k}}$$

$$\text{Time period} = t_1 + t_2 = \left[ \frac{\pi}{\sqrt{3k}} \sqrt{M} + \pi \sqrt{\frac{M}{k}} \right]$$

$$= \pi \sqrt{\frac{M}{k}} \left[ 1 + \frac{1}{\sqrt{3}} \right]$$

40)

Ans: a

Exp:  $\Delta l = \left(\frac{l}{YA}\right) \cdot W$

i.e., graph is a straight line passing through origin

(as shown in question also), the slope of which is  $l/YA$ .

$\therefore$  Slope =  $(l/YA)$

$\therefore Y = (l/A) (1/\text{slope}) = (1.0/10^{-6}) ((80-20)/((4-1) \times 10^{-4}))$   
 $= 2.0 \times 10^{11} \text{N/m}^2$

41)

Ans: b

Exp: After two seconds both the pulses will move 4cm towards each other. So, by their superposition, the resultant displacement at every point will be zero. Therefore, total energy will be purely in the form of kinetic. Half of the particles will be moving upwards and half downwards.

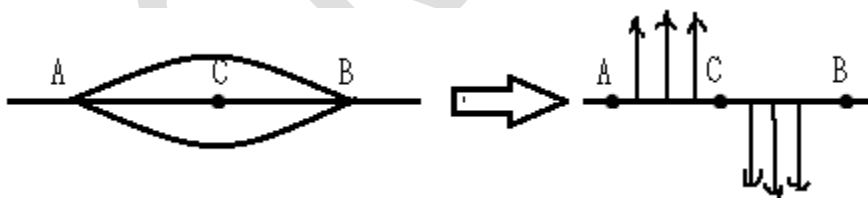

42)

Ans: c



$$f_c = f_o \quad (\text{both first overtone})$$

Exp: or  $3\left(\frac{v_c}{4L}\right) = 2\left(\frac{v_o}{2l_o}\right)$

$$\therefore l_o = \frac{4}{3}\left(\frac{v_o}{v_c}\right)L = \frac{4}{3}\sqrt{\frac{\rho_1}{\rho_2}}L \quad \text{as } v \propto \frac{1}{\sqrt{\rho}}$$

43)

Ans: c

Exp:  $W_{AB} = -P_0 V_0$   
 $W_{BC} = 0$  and  $W_{CD} = 4P_0 V_0$   
 $\therefore W_{ABCD} = -P_0 V_0 + 0 + 4P_0 V_0 = 3P_0 V_0$

44)

Ans: c

Exp: From the first lens parallel beam of light is focused at its focus i.e., at a distance  $f_1$  from it. This image  $I_1$  acts as virtual object for second lens  $L_2$ .

Therefore, for  $L_2$

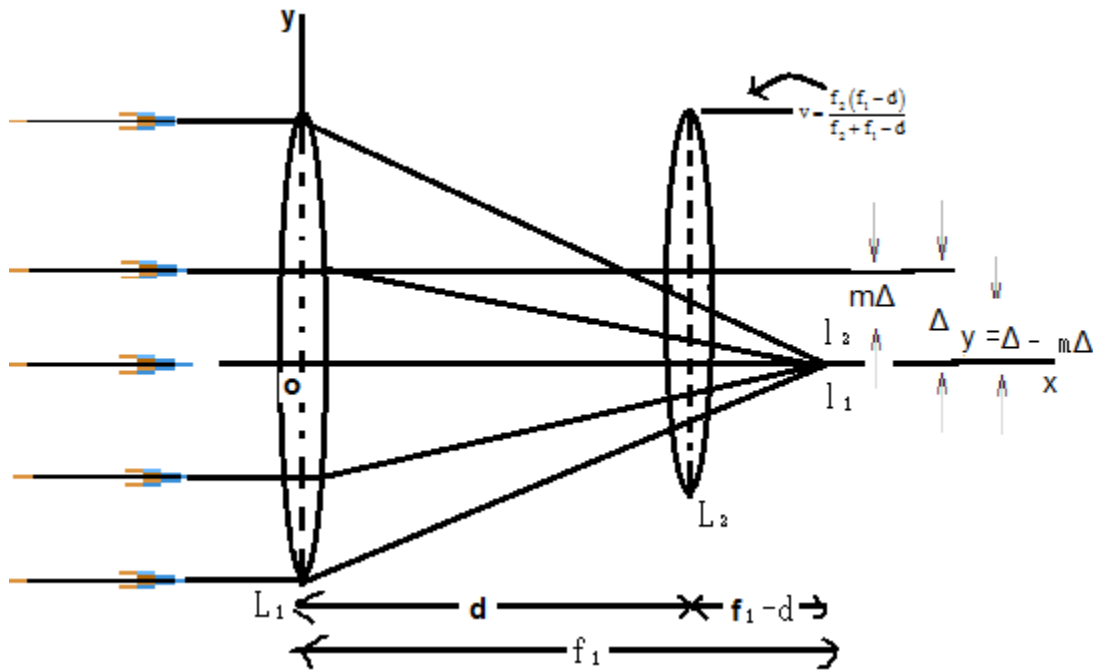

$$u = +(f_1 - d), f = +f_2$$

$$\therefore \frac{1}{v} = \frac{1}{f} + \frac{1}{u} = \frac{1}{f_2} + \frac{1}{f_1 - d}$$

$$\text{Hence, } v = \frac{f_2(f_1 - d)}{f_2 + f_1 - d}$$

Therefore, x-coordinate of its focal point will be

$$x = d + v = d + \frac{f_2(f_1 - d)}{f_2 + f_1 - d} = \frac{f_1 f_2 + d(f_1 - d)}{f_1 + f_2 - d}$$

Linear magnification for  $L_2$

$$m = \frac{v}{u} = \frac{f_2(f_1 - d)}{f_2 - f_1 - d} \cdot \frac{1}{f_1 - d} = \frac{f_2}{f_2 + f_1 - d}$$

Therefore, second image will be formed at a distance of  $m\Delta$  or

$$\left( \frac{f_2}{f_2 + f_1 - d} \right) \Delta \text{ below its optic axis.}$$

Therefore, y-coordinate of the focus of system will be

$$y = \Delta - \left( \frac{f_2 \Delta}{f_2 + f_1 - d} \right) \quad \text{or} \quad y = \frac{(f_1 - d) \cdot \Delta}{f_2 + f_1 - d}$$

45)

Ans: c

Exp: The diagrammatic represents of the given problem is shown in figure.

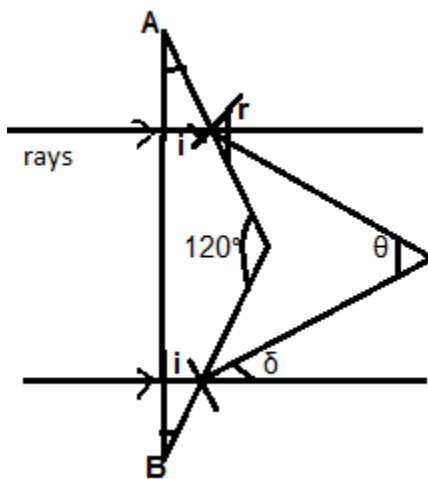

From figure it follows that  $\angle i = \angle A = 30^\circ$

From Snell's law,  $n_1 \sin i = n_2 \sin r$

$$\sin r = \frac{1.44 \sin 30^\circ}{1} = 0.72$$

or Now,  $\angle \delta = \angle r - \angle i = \sin^{-1}(0.72) - 30^\circ$

$$\therefore \theta = 2(\angle \delta) = 2\{\sin^{-1}(0.72) - 30^\circ\}$$

46)

Ans: c

Exp: Distance of object from mirror

$$= 15 + 33.25/1.33 = 40\text{cm}$$

Distance of image from mirror

$$= 15 + 25/1.33 = 33.8\text{cm}$$

For the mirror,  $1/v + 1/u = 1/f$

$$\therefore 1/-33.8 + 1/-40 = 1/f$$

$$\therefore f = -18.3\text{cm}$$

$\therefore$  most suitable answer is ©.

47)

Ans: a

Exp:  $v_A - v_B =$  work done by electric field on + 1coul. Charge from A to B =  $E R\theta$

$$\therefore V_B = V_A - Er\theta = v - ER\theta$$

48)

Ans: b

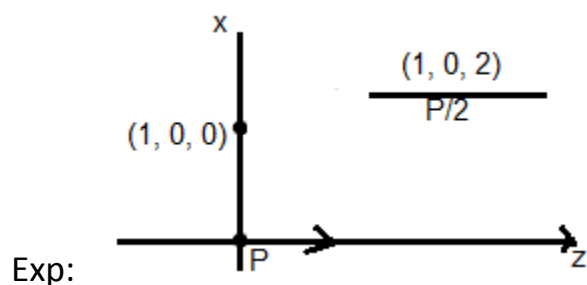

The given point is at axis of  $\vec{P}/2$  dipole and at equatorial line of  $\vec{P}$  dipole so total field at given point is.

$$\vec{E} = -\frac{k\vec{P}}{(1)^3} + \frac{2k(\vec{P}/2)}{(2)^3} = k\vec{P}\left(-1 + \frac{1}{8}\right) = \frac{-7\vec{P}}{32\pi\epsilon_0}$$

49)

Ans: c

Exp:  $\phi = \vec{E} \cdot \vec{ds}$

Since  $r \ll R$  so we can consider electric field is constant throughout the surface of smaller ring, hence

$$\phi \propto E \propto \frac{x}{(R^2 + x^2)^{3/2}}$$

So, the best represented graph is C.

50)

Ans: b

Exp:  $\vec{E} = -\nabla V = +\frac{1}{x^2}\hat{i} + \frac{1}{y^2}\hat{j} + \frac{1}{z^2}\hat{k} = \hat{i} + \hat{j} + \hat{k}$

51)

Ans: a

$$V = E - ir = E - \left(\frac{E}{R+r}\right)r = \frac{ER}{R+r}$$

Exp: Hence,  $18 = \frac{6E}{6+r}$  .....(1)

and  $24 = \frac{12E}{12+r}$  .....(2)

Solving Eqs. (1) and (2), we get

$$r = 6\Omega \text{ and } E = 36V$$

when both  $S_1$  and  $S_2$  are closed external resistance in the circuit will be

$$R = \frac{(6)(12)}{6+12} = 4\Omega$$

$$\therefore V = \frac{(36)(4)}{4+6} = 14.4V$$

52)

Ans: b

$$i_1 = \frac{V}{R} e^{-t/2CR}$$

Exp: and  $i_2 = \frac{V}{R} e^{-t/CR}$

$$\therefore \frac{i_1}{i_2} = e^{t/2CR}$$

i.e., the desired ratio increases with time.

53)

Ans: c

Exp:  $U = \frac{1}{2} C V^2 = 0.15\text{mJ}$

This energy will be dissipated in the resistors in the ratio of their resistances.

$$\therefore H_{4\Omega} = (4/6) (0.15) = 0.1\text{mJ}$$

54)

Ans: d

Exp: Net resistance of the circuit is  $9\Omega$

$\therefore$  Current drawn from the battery,

$$i = 9/9 = 1\text{A}$$

= current through  $3\Omega$  resistor

Potential difference between A and B is

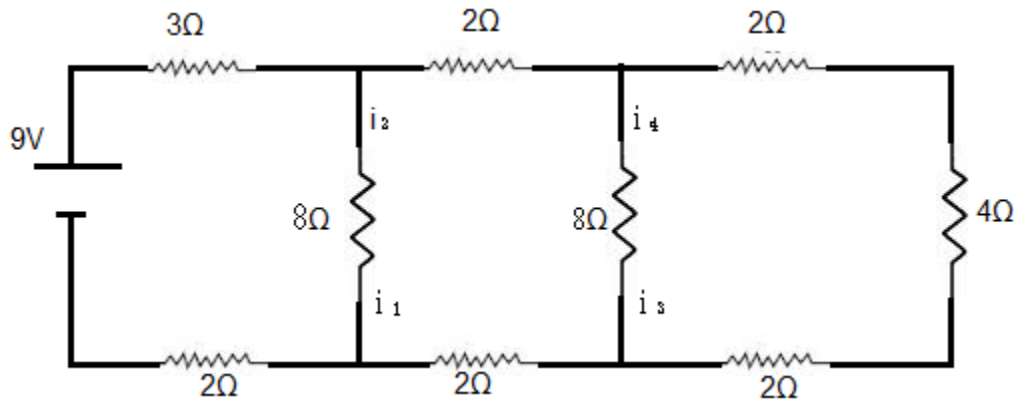

$$V_A - V_B = 9 - 1(3+2) = 4V = 8i_1$$

$$\therefore i_1 = 0.5A$$

$$\therefore i_2 = 1 - i_1 = 0.5A$$

Similarly, potential difference between C and D

$$\begin{aligned} V_C - V_D &= (V_A - V_B) - i_2(2+2) \\ &= 4 - 4i_2 = 4 - 4(0.5) = 2V = 8i_3 \end{aligned}$$

$$\therefore i_3 = 0.25A$$

$$\text{Therefore, } i_4 = i_2 - i_3 = 0.5 - 0.25$$

$$i_4 = 0.25A$$

55)

Ans: b



Exp:  $V = E - ir = -\frac{Er}{R+r} = E \left[ \frac{R+r-r}{R+r} \right] \Rightarrow V = \frac{ER}{(R+r)} \Rightarrow V = 0 \text{ at } R = 0$   
 $V = E \text{ at } R = \infty$

So (B) is correct option.

56)

Ans: b

Exp: From the figure,

$$AC_1 = AC_2 = C_1C_2 = \text{radius}$$

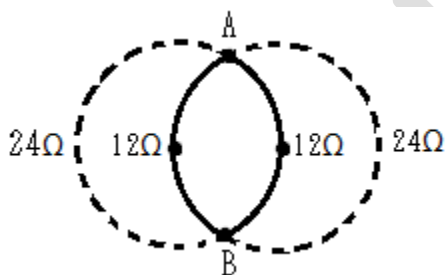

$$\therefore \angle AC_1B = 120^\circ$$

Hence the resistance of four sections are

Hence equivalent resistance R across AB is

$$1/R = 1/24 + 1/12 + 1/12 + 1/24 \text{ or } R = 4\Omega$$

$$\therefore \text{Power} = V^2/R = (20)^2/4 = 100\text{Watt.}$$

57)

Ans: d

Exp:  $R = \frac{1}{\sigma} \cdot \frac{t}{4\pi R^2}$

Using values  $R = 5 \times 10^{-11} \Omega$

58)

Ans: b

Exp: From relation  $E = \rho J$ , the magnitude of electric field is greater in right rod as compared to left rod. Therefore magnitude of potential gradient in the right rod is greater. (remember potential is continuous).

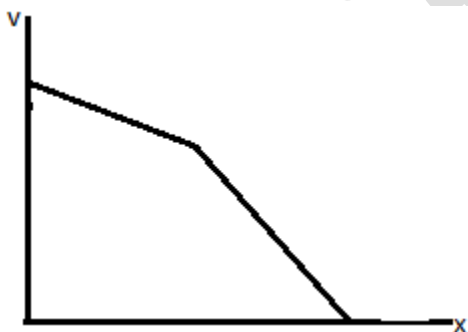

Therefore the variation is shown by figure.

59)

Ans: c

Exp: Energy is released in a process when total binding energy of the nucleus (= binding energy per nucleon x number of nucleons) is increased or we can say,

when total binding energy of products is more than the reactants. By calculation we can see that only in option (c), this happens

Given:  $W \rightarrow 2Y$

Binding energy of reactants =  $120 \times 7.5 = 900\text{MeV}$

And binding energy of products =  $2(60 \times 8.5)$

=  $1020\text{MeV} > 900\text{MeV}$ .

60)

Ans: a

Exp: As the current  $i$  leads the emf  $e$  by  $\pi/4$ , it is an R – C circuit.

$$\tan \phi = X_C/R \text{ or } \tan \pi/4 = \frac{1}{\omega C/R} \quad \therefore \quad \omega CR = 1$$

As  $\omega = 100\text{rad/s}$

The product of C – R should be  $1/100 \text{ s}^{-1}$

$\therefore$  correct answer is (a).

### PART – C – MATHEMATICS

61)

Ans: a

Exp:  $\log_{0.3}(x-1) < \log_{0.09}(x-1)$

$\Rightarrow x-1 > 0$

and  $\log_{(0.3)}(x-1) < \log_{(0.3)^2}(x-1)$

$\Rightarrow x > 1$

and  $\log_{0.3}(x-1) < \frac{1}{2} \log_{0.3}(x-1)$

$\Rightarrow x > 1$  and  $\log_{0.3}(x-1) < 0$

$\Rightarrow x > 1$  and  $x-1 > 1$

$\Rightarrow x > 1$  and  $x > 2$

$\Rightarrow x \in (2, \infty)$

62)

Ans: d

Exp: We know that  $|z - z_1| > |z - z_2|$  represents the region on right side of perpendicular bisector of  $z_1$  and  $z_2$ .

Thus, the given inequality  $|z - 2| > |z - 4|$  represents the region on right side of perpendicular bisector of 2 and 4.

$\Rightarrow \operatorname{Re}(z) > 3$  and  $\operatorname{Im}(z) \in \mathbb{R}$ .

63)

Ans: a

Exp: Let  $P(x_1, y_1)$  be any point on the circle  $x^2 + y^2 + 2gx + 2fy + c = 0$ . Then, the length of the tangents drawn from  $P(x_1, y_1)$  to the circle

$$x^2 + y^2 + 2gx + 2fy + c \sin^2 \alpha + (g^2 + f^2) \cos^2 \alpha = 0 \text{ is } PQ = PR$$

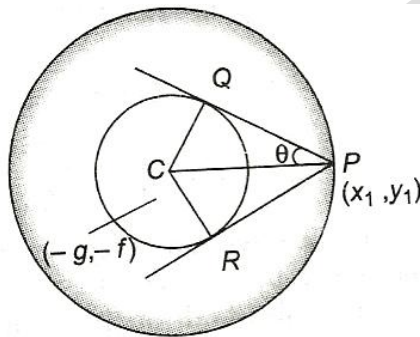

$$= \sqrt{[x_1^2 + y_1^2 + 2gx_1 + 2fy_1 + c \sin^2 \alpha + (g^2 + f^2) \cos^2 \alpha]}$$

$$= \sqrt{-c + c \sin^2 \alpha + (g^2 + f^2) \cos^2 \alpha}$$

$$= (\sqrt{g^2 + f^2 - c}) \cos \alpha$$

The radius of the circle

$$x^2 + y^2 + 2gx + 2fy + c \sin^2 \alpha + (g^2 + f^2) \cos^2 \alpha = 0 \text{ is } CQ = CR$$

$$= \sqrt{g^2 + f^2 - c \sin^2 \alpha - (g^2 + f^2) \cos^2 \alpha}$$

$$= \sqrt{(g^2 + f^2 - c)} \sin \alpha$$

In  $\Delta PQC$ ,

$$\tan\theta = \frac{CQ}{PQ}$$

$$\Rightarrow \tan\theta = \frac{\sqrt{(g^2 + f^2 - c)} \sin \alpha}{\sqrt{(g^2 + f^2 - c)} \cos \alpha}$$

$$= \tan \alpha$$

$$\Rightarrow \theta = \alpha$$

64)

Ans: a

$$\text{Exp: } f(\theta) = \frac{d}{d\theta} \int_0^\theta \frac{dx}{1 - \cos \theta \cos x}$$

Using Leibnitz's rule,

$$\begin{aligned} f(\theta) &= \frac{1}{1 - \cos^2 \theta} (1 - 0) \\ &= \frac{1}{1 - \cos^2 \theta} = \operatorname{cosec}^2 \theta \end{aligned}$$

On differentiating w.r.t.  $\theta$ , we get

$$\frac{df}{d\theta} = -2 \operatorname{cosec}^2 \theta \cot \theta$$

$$\Rightarrow \frac{df}{d\theta} + 2f(\theta) \cot \theta = 0$$

AskIITians

B - 147, 1st Floor, Sec-6, NOIDA, UP-201301,  
Website: [www.askiitians.com](http://www.askiitians.com), Email: [info@askiitians.com](mailto:info@askiitians.com)  
Tel: 1800 2000 838 (Toll free)

65)

Ans: b

Exp: Let  $(\sqrt{3} + 1)^{2m} = I + F$ , where  $I \in \mathbb{N}$  and  $0 < F < 1$ .

Let  $G = (\sqrt{3} - 1)^{2m}$ . Then,

$$\begin{aligned} I + F + G &= (\sqrt{3} + 1)^{2m} + (\sqrt{3} - 1)^{2m} \\ &= 2^m (2 + \sqrt{3})^m + 2^m (2 - \sqrt{3})^m \\ &= 2^{m+1} \times \text{an integer} \quad \dots\dots\dots (i) \end{aligned}$$

$\Rightarrow I + F + G = \text{an even integer}$

$\Rightarrow F + G = \text{an even integer} - I$

$\Rightarrow F + G = \text{an integer}$

$\Rightarrow F + G = 1$

$(\because 0 < F < 1, 0 < G < 1)$

Putting  $F + G = 1$  in Eq. (i), we get

$$I + 1 = 2^{m+1} \times \text{an integer}$$

$\Rightarrow 2^{m+1}$  is a factor of the integer just greater than  $(\sqrt{3} + 1)^{2m}$ .

66)

Ans: a

Exp: Since,  $f(x) = \sqrt{\cos(\sin x)} + \sin^{-1}\left(\frac{1+x^2}{2x}\right)$

We know that  $\sqrt{\cos(\sin x)}$  is defined  $\forall x \in \mathbb{R}$  and  $\sin^{-1}\left(\frac{1+x^2}{2x}\right)$  is defined only  $x \in \{-1, 1\}$

$\therefore f(x)$  is defined for  $x \in \{-1, 1\}$ .

67)

Ans: b

Exp: Let  $f(x) = \log(1+x) - x, \forall x > -1$

On differentiating w.r.t.  $x$ , we get

$$\begin{aligned} f'(x) &= \frac{1}{1+x} - 1 = \frac{1-1-x}{1+x} \\ &= \frac{-x}{1+x} \end{aligned}$$

$\Rightarrow f(x)$  is increasing for  $-1 < x \leq 0$ .

and decreasing for  $x > 0$ .

$\Rightarrow f(x)$  is decreasing on  $(0, \infty)$

and increasing on  $(-1, 0]$

$\Rightarrow f(x) \leq f(0), \forall 0 \leq x < \infty$

and  $f(x) \leq f(0), \forall -1 < x \leq 0$

$\Rightarrow f(x) \leq f(0), \forall -1 < x < \infty$



$$\Rightarrow \log(1+x) - x \leq 0, \forall -1 < x < \infty$$

$$\Rightarrow \log(1+x) \leq x, \forall x \in (-1, \infty).$$

68)

Ans: a

Exp: Since,  $y = (2x - 1)e^{2(1-x)}$

$$\begin{aligned} \therefore \frac{dy}{dx} &= 2e^{2(1-x)} - 2(2x-1)e^{2(1-x)} \\ &= 4e^{2(1-x)}(1-x) \end{aligned}$$

For maxima or minima, put  $\frac{dy}{dx} = 0$

$$4e^{2(1-x)}(1-x) = 0$$

$$\Rightarrow x = 1$$

$$\text{Now, } \frac{d^2y}{dx^2} = -8e^{2(1-x)}(1-x) - 4e^{2(1-x)}$$

$$\therefore \left(\frac{d^2y}{dx^2}\right)_{x=1} = -4 < 0$$

So,  $y$  is maximum at  $x = 1$ , when  $y = 1$ .

Thus, the point of maximum is  $(1, 1)$ .

The equation of the tangent at  $(1, 1)$  is

$$y - 1 = 0(x - 1)$$

$$\Rightarrow y = 1$$

AskIITians

B - 147, 1st Floor, Sec-6, NOIDA, UP-201301,  
Website: [www.askiitians.com](http://www.askiitians.com), Email: [info@askiitians.com](mailto:info@askiitians.com)  
Tel: 1800 2000 838 (Toll free)

69)

Ans: b

Exp: Since,  $\vec{OP}$  has projections  $\frac{13}{5}$ ,  $\frac{19}{5}$  and  $\frac{26}{5}$  on the coordinate axes, therefore

$$\vec{OP} = \frac{13}{5}\hat{i} + \frac{19}{5}\hat{j} + \frac{26}{5}\hat{k}.$$

Suppose, P divides the join of Q (2, 2, 4) and R (3, 5, 6) in the ratio  $\lambda : 1$ , then

$$\vec{OP} = \left(\frac{3\lambda+2}{\lambda+1}\right)\hat{i} + \left(\frac{5\lambda+2}{\lambda+1}\right)\hat{j} + \left(\frac{6\lambda+4}{\lambda+1}\right)\hat{k}$$

$$\begin{aligned} \therefore \quad \frac{13}{5}\hat{i} + \frac{19}{5}\hat{j} + \frac{26}{5}\hat{k} &= \left(\frac{3\lambda+2}{\lambda+1}\right)\hat{i} + \left(\frac{5\lambda+2}{\lambda+1}\right)\hat{j} + \left(\frac{6\lambda+4}{\lambda+1}\right)\hat{k} \end{aligned}$$

$$\Rightarrow \frac{3\lambda+2}{\lambda+1} = \frac{13}{5}, \frac{5\lambda+2}{\lambda+1} = \frac{19}{5}$$

$$\text{And } \frac{6\lambda+4}{\lambda+1} = \frac{26}{5}$$

$$\Rightarrow 5(3\lambda+2) = 12(\lambda+1)$$

$$\Rightarrow \lambda = \frac{3}{2}$$

Thus, required ratio is 3: 2.

70)

Ans: b

$$\begin{aligned}
 \text{Exp: } f(x) &= \sin^2 x + \sin^2 \left( x + \frac{\pi}{3} \right) \\
 &\quad + \cos x \cos \left( x + \frac{\pi}{3} \right) \\
 &= \sin^2 x + \left( \sin x \cos \frac{\pi}{3} + \cos x \sin \frac{\pi}{3} \right)^2 \\
 &\quad + \cos x \left( \cos x \cos \frac{\pi}{3} - \sin x \sin \frac{\pi}{3} \right) \\
 &= \sin^2 x + \frac{\sin^2 x}{4} + \frac{3\cos^3}{4} + \frac{2\sqrt{3}}{2.2} \sin x \cos x \\
 &\quad + \frac{\cos^2 x}{2} - \cos x \sin x \frac{\sqrt{3}}{2} \\
 &= \sin^2 x + \frac{\sin^2 x}{4} + \frac{3\cos^2 x}{4} + \frac{\cos^2 x}{2} \\
 &= \frac{5\sin^2 x}{4} + \frac{3\cos^2 x + 2\cos^2 x}{4} \\
 &= \frac{5\sin^2 x}{4} + \frac{3\cos^2 x + 2\cos^2 x}{4} = \frac{5}{4} (\sin^2 x + \cos^2 x) = \frac{5}{4} \\
 \therefore \text{gof}(x) &= g[f(x)] = g\left(\frac{5}{4}\right) = 1
 \end{aligned}$$

71)

Ans: c

Exp: Let the centre be  $O(h, k)$ .

So,  $OA_2 = OB_2$

and (slope of OA) (slope of tangent at A) = - 1

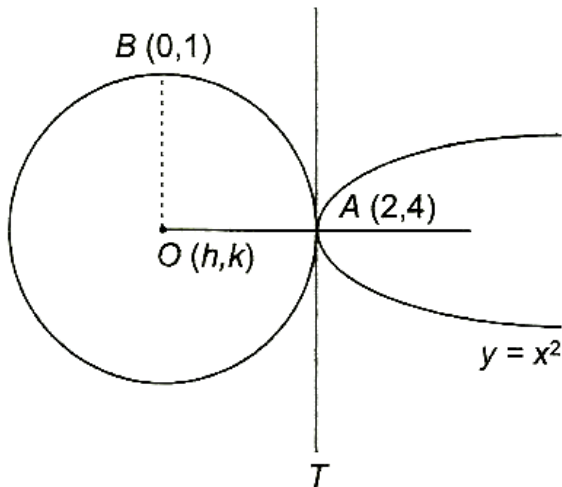

$$\Rightarrow (h-2)^2 + (k-4)^2 = h^2 + (k-1)^2$$

$$\Rightarrow 4h + 6k - 19 = 0 \quad \dots\dots\dots (i)$$

Also, slope of OA =  $\frac{k-4}{h-2}$

and equation of tangent at  $(2, 4)$  to  $y = x^2$  is  $y + 4 = 2x$ , its slope is 2.

$$\therefore \frac{k-4}{h-2} \cdot 4 = -1 (\because m_1 m_2 = -1)$$

$$\Rightarrow 4k - 16 = -h + 2$$

$$\Rightarrow h + 4k = 18 \quad \dots\dots\dots (ii)$$

On solving Eqs. (i) and (ii), we get

$$h = -\frac{16}{5} \text{ and } k = \frac{53}{10}$$

$$\therefore \text{Coordinates of centre are } \left(-\frac{16}{5}, \frac{53}{10}\right).$$

72)

Ans: d

Exp:  $a-b+c \geq -4 \quad \dots\dots\dots (1)$

And  $a+b+c \leq 0$

$$\Rightarrow -a - b - c \geq 0 \dots\dots\dots (2)$$

$$\text{and } 9a + 3b + c \geq 5 \dots\dots\dots (3)$$

From equation (i)+(ii)

$$\Rightarrow -2b \geq -4 \quad \dots\dots\dots (4)$$

From equation (ii)+(iii)+(iv)

$$\Rightarrow 8a \geq 1 \Rightarrow a \geq 1/8$$

73)

Ans: b

Exp: Given that,

$$x^2 + y^2 + z^2 = r^2 \quad \dots\dots\dots(i)$$

$$\therefore \tan^{-1}\left(\frac{xy}{zr}\right) + \tan^{-1}\left(\frac{yz}{xr}\right) + \tan^{-1}\left(\frac{xz}{yr}\right)$$

$$= \tan^{-1}\left[\frac{\frac{xy}{zr} + \frac{yz}{xr} + \frac{xz}{yr} - \frac{xyz}{r^3}}{1 - \left(\frac{x^2 + y^2 + z^2}{r^2}\right)}\right]$$

$$[\because \tan^{-1} a + \tan^{-1} b + \tan^{-1} c]$$

$$= \tan^{-1}\left(\frac{a + b + c - abc}{1 - (ab + bc + ca)}\right)$$

$$= \tan^{-1}(\infty) = \frac{\pi}{2} \quad \text{[from Eq. (i)]}$$

74)

Ans; b

Exp: a, b, c, d are in G.P., let they are a, ar, ar<sup>2</sup>, ar<sup>3</sup>

$$\begin{aligned} & (a^2 + b^2 + c^2)(b^2 + c^2 + d^2) \\ &= a^2 X a^2 [1 + r^2 + r^4] [r^2 + r^4 r^6] \\ &= a^4 r^2 [1 + r^2 + r^4]^2 = [a^2 r (1 + r^2 + r^4)]^2 \\ &= (ab + bc + cd)^2 \end{aligned}$$

75)

Ans: c

Exp: Total number of elementary events associated to the random experiment of throwing 4 dice

$$= 6 \times 6 \times 6 \times 6 = 6^4$$

Favourable number of elementary events

$$= \text{coefficient of } x^{13} \text{ in } (x + x^2 + x^3 + \dots + x^6)^4$$

$$= \text{coefficient of } x^9 \text{ in } (1 + x + \dots + x^5)^4$$

$$= \text{coefficient of } x^9 \text{ in } \left( \frac{1-x^6}{1-x} \right)^4$$

$$= \text{coefficient of } x^9 \text{ in } (1-x^6)^4 (1-x)^{-4}$$

$$= \text{coefficient of } x^9 \text{ in } (1-x)^{-4}$$

$$- 4 \text{ coefficient of } x^3 \text{ in } (1-x)^{-4}$$

$$= {}^{9+4-1}C_{4-1} - 4 \times {}^{3+4-1}C_{4-1}$$

$$= {}^{12}C_3 - 4 \times {}^6C_3$$

$$= \frac{12 \times 11 \times 10}{3 \times 2 \times 1} - 4 \times \frac{6 \times 5 \times 4}{3 \times 2 \times 1}$$

$$= 220 - 80 = 140$$

Hence, required probability  $\frac{140}{6^4} = \frac{35}{324}$

76)

Ans: a

Exp: Let the angles are  $A = x - d$ ,  $B = x$  and  $C = x + d$ .

$$\therefore x - d + x + x + d = 180^\circ$$

$$\Rightarrow x = 60^\circ$$

$\therefore$  Two larger angles are B and C.

Thus, sides are

$$b = 9 \text{ and } c = 10$$

$$\text{Now, } \cos B = \frac{c^2 + a^2 - b^2}{2ac}$$

$$\Rightarrow \cos 60^\circ = \frac{1}{2} = \frac{100 + a^2 - 81}{20a}$$

$$\Rightarrow a^2 - 10a + 19 = 0$$

$$\Rightarrow a = \frac{10 \pm \sqrt{100 - 76}}{2} = 5 \pm \sqrt{6}$$

77)

Ans: b

Exp: Since,  $(z + a\beta)^3 = a^3$

$$\Rightarrow z = a - a\beta, z = a\omega = a\beta, z = a\omega^2 - a\beta$$

Thus, the vertices A, B and C of a  $\Delta$  ABC are respectively  $a - a\beta$ ,  $a\omega - a\beta$  and  $a\omega^2 - a\beta$ .

(If the vertices of a triangle are the cube roots of unity, then it is an equilateral triangle.)



Clearly,  $AB = BC = AC$

$$= |a||1 - \omega| = \sqrt{3}|a|$$

78)

Ans: a

Exp:  $\lim_{x \rightarrow 1} \int_4^{f(x)} \frac{2t}{x-1} dt = \lim_{x \rightarrow 1} \frac{1}{x-1} [y^2]_4^{f(x)}$

$$\lim_{x \rightarrow 1} \frac{f^2(x) - 16}{x-1}$$

Applying L' Hospital's rule,

$$= \lim_{x \rightarrow 1} \frac{2f(x)f'(x)}{1}$$

$$= 2f(1)f'(1) = 8f'(1)$$

79)

Ans: b

Exp: Since,  $k^2x - 1 < [k^2x] \leq k^2x + 1$ , where  $k \in I$

$$\Rightarrow \frac{1}{n^3} \sum_{k=1}^n (k^2x - 1) < \frac{1}{n^3} \sum_{k=1}^n [k^2x]$$

$$\leq \frac{1}{n^3} \sum_{k=1}^n (k^2x + 1)$$

$$\Rightarrow \left\{ \frac{1}{n^3} \left( \frac{n(n+1)(2n+1)}{6} \right) x - \frac{n}{n^3} \right\}$$

**AskIITians**

B - 147, 1st Floor, Sec-6, NOIDA, UP-201301,  
Website: [www.askiitians.com](http://www.askiitians.com), Email: [info@askiitians.com](mailto:info@askiitians.com)  
Tel: 1800 2000 838 (Toll free)

$$\begin{aligned}
 &< \frac{1}{n^3} \sum_{k=1}^n [k^2 x] \\
 &\leq \left\{ \frac{1}{n^3} \left( \frac{n(n+1)(2n+1)}{6} \right) x + \frac{n}{n^3} \right\} \\
 \Rightarrow &\left\{ \left( \frac{2n^2 + 3n + 1b}{6n^2} \right) x - \frac{1}{n^2} \right\} < \frac{1}{n^3} \sum_{k=1}^n [k^2 x] \\
 &\leq \left\{ \left( \frac{2n^2 + 3n + 1}{6n^2} \right) x + \frac{1}{n^2} \right\} \\
 \Rightarrow &\frac{x}{3} - 0 < \lim_{n \rightarrow \infty} \frac{1}{n^3} \sum_{k=1}^n [k^2 x] \frac{x}{3} \\
 \Rightarrow &\lim_{n \rightarrow \infty} \frac{1}{n^3} \sum_{k=1}^n [k^2 x] = \frac{x}{3}
 \end{aligned}$$

80)

Ans: b

Exp: Since,  $f(x) = x^n$

$$\therefore f(x+y) = (x+y)^n$$

$$\Rightarrow f'(x+y) = n(x+y)^{n-1}$$

$$\text{Also, } f'(x) = nx^{n-1} \text{ and } f'(y) = ny^{n-1}$$

$$\text{Given, } f'(x+y) = f'(x) + f'(y)$$

$$\therefore n(x+y)^{n-1} = nx^{n-1} + ny^{n-1}$$

$$\Rightarrow (x+y)^{n-1} = x^{n-1} + y^{n-1}$$

For  $n - 1 > 1$ , LHS > RHS

So, for  $n - 1 \leq 1$  ie,  $n - 1 = 0$  or  $n - 1 = 1$

Since,  $n$  is non-negative integer, hence  $n$  is 1.

81)

Ans: a

Exp: Now,

$$\begin{aligned}
 & \sum_{m=1}^n \tan^{-1} \left( \frac{2m}{m^4 + m^2 + 2} \right) \\
 &= \sum_{m=1}^n \tan^{-1} \left( \frac{2m}{1 + (m^2 + m + 1)(m^2 - m + 1)} \right) \\
 &= \sum_{m=1}^n \tan^{-1} \left[ \frac{(m^2 + m + 1) - (m^2 - m + 1)}{1 + (m^2 + m + 1)(m^2 - m + 1)} \right] \\
 &= \sum_{m=1}^n \left[ \tan^{-1}(m^2 + m + 1) - \tan^{-1}(m^2 - m + 1) \right] \\
 &= (\tan^{-1} 3 - \tan^{-1} 1) + (\tan^{-1} 7 - \tan^{-1} 3) \\
 &\quad + \dots + \tan^{-1}(n^2 + n + 1) - \tan^{-1}(n^2 - n + 1) \\
 &= \tan^{-1} \left( \frac{n^2 + n + 1 - 1}{1 + (n^2 + n + 1) \cdot 1} \right) \\
 &= \tan^{-1} \left( \frac{n^2 + n}{n^2 + n + 2} \right)
 \end{aligned}$$

82)

Ans: b

Exp: The total number of two factors product =  ${}^{200}C_2$ . The number of numbers from 1 to 200 which are not multiples of 5 is 160. Therefore, total number of two factors products which are not multiple of 5 is  ${}^{100}C_2$ .

Hence, the required number of factors.

$$= {}^{200}C_2 - {}^{160}C_2 = \frac{200!}{2!198!} - \frac{160!}{2!158!}$$

$$= 19900 - 12720 = 7180$$

83)

Ans: a

Exp: Since,  $2|\hat{i} + x\hat{j} + 3\hat{k}| = |4\hat{i} + (4x-2)\hat{j} + 2\hat{k}|$

$$\Rightarrow 2\sqrt{1^2 + x^2 + 3^2} = \sqrt{16 + (4x-2)^2 + 2^2}$$

$$\Rightarrow 4(x^2 + 10) = 20 + (4x-2)^2$$

$$\Rightarrow 3x^2 - 4x - 4 = 0$$

$$\Rightarrow (3x+2)(x-2) = 0$$

$$\Rightarrow x = 2, -\frac{2}{3}$$

84)

Ans: c

Exp: Let  $z = x + iy$

$$\therefore \sqrt{x^2 + (y-1)^2} + \sqrt{x^2 + (y+1)^2} = k \quad \dots(i)$$

$$\begin{aligned} \Rightarrow x^2 + (y-1)^2 - x^2 - (y+1)^2 \\ = k \left\{ \sqrt{x^2 + (y-1)^2} - \sqrt{x^2 + (y+1)^2} \right\} \end{aligned}$$

$$\begin{aligned} \therefore \sqrt{x^2 + (y-1)^2} - \sqrt{x^2 + (y+1)^2} \\ = -\frac{4y}{k} \quad \dots (ii) \end{aligned}$$

From Eqs. (i) and (ii),

$$2\sqrt{x^2 + (y-1)^2} = k - \frac{4y}{k}$$

$$\Rightarrow 4x^2 + \left(4 - \frac{16}{k^2}\right)y^2 = k^2 - 4$$

For an ellipse,  $4 - \frac{16}{k^2} > 0 \Rightarrow k^2 - 4 > 0$

$$\Rightarrow k^2 > 4$$

85)

Ans: b

$$\text{Exp: } A_1 = 2 \int_0^a \sqrt{4ax} dx = 4\sqrt{a} \int_0^a \sqrt{x} dx$$

$$= 4\sqrt{a} \frac{2}{3} [x^{3/2}]_0^a$$

$$= \frac{8a^2}{3} \text{ sq unit}$$

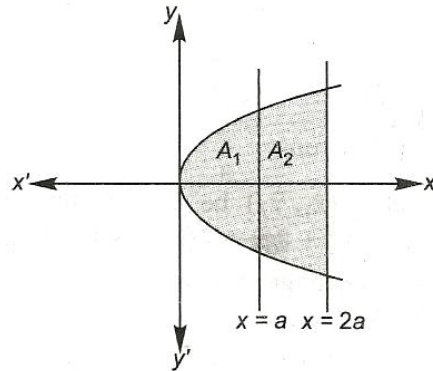

and  $A^2 = 2 \left[ \int_a^{2a} \sqrt{4ax} dx \right]$

$$= \frac{8\sqrt{a}}{3} [x^{3/2}]_0^{2a}$$

$$= \frac{8a^2}{3} [2\sqrt{2}-1] \text{ sq unit}$$

$$\therefore \frac{A_1}{A_2} = \frac{1}{2\sqrt{2}-1} = \frac{2\sqrt{2}+1}{7}$$

86)

Ans: c

Exp: In  $\triangle ACB$ ,

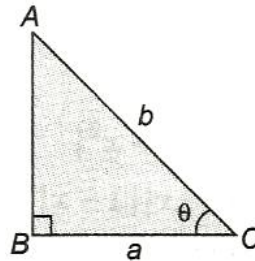

$$b \cos \theta = a \quad \dots (i)$$

Given  $b \cos \theta + b = 4$  ( $\because b + a = 4$  given)

$$b = \frac{4}{1 + \cos \theta}$$

From Eq. (i)

$$a = \frac{4 \cos \theta}{1 + \cos \theta}$$

$\therefore$  Area of triangle,

$$\begin{aligned} \Delta &= \frac{1}{2} ba \sin \theta \\ &= \frac{1}{2} \cdot \frac{4}{1 + \cos \theta} \cdot \frac{4 \cos \theta}{1 + \cos \theta} \cdot \sin \theta \\ &= \frac{4 \sin 2\theta}{(1 + \cos \theta)^2} \end{aligned}$$

$$\therefore \frac{d\Delta}{d\theta} = 4 \frac{[2 \cos 2\theta (1 + \cos \theta)^2 + \sin 2\theta \cdot 2(1 + \cos \theta) \sin \theta]}{(1 + \cos \theta)^4}$$

$$= \frac{8[\cos 2\theta(1 + \cos \theta) + \sin 2\theta \sin \theta]}{(1 + \cos \theta)^3}$$

For maxima or minima, put  $\frac{d\Delta}{d\theta} = 0$

$$\Rightarrow \cos 2\theta (1 + \cos \theta) + \sin 2\theta \sin \theta = 0$$

$$\Rightarrow \cos 2\theta + (\cos 2\theta \cos \theta + \sin 2\theta \sin \theta) = 0$$

$$\Rightarrow \cos 2\theta + \cos \theta = 0$$

$$\therefore \cos 2\theta = -\cos \theta = \cos(\pi - \theta)$$

$$\Rightarrow \theta = \frac{\pi}{3}$$

$$\therefore \Delta \text{ is maximum when } \theta = \frac{\pi}{3}$$

87)

Ans: b

Exp: Since, a person can alight at any one of n floors. Therefore, the number of ways in which m passengers can alight at n floors is  $\underbrace{nxnxnx\dots xn}_{m \text{ times}} = n^m$

The number of ways in which all passengers can alight at different floors is  ${}^n C_m \times m! = {}^n P_m$ .

Hence, required probability =  $\frac{{}^n P_m}{n^m}$



88)

Ans: d

Exp: If  $y = \sin mx$

$$y_1 = m \cos mx$$

$$y_2 = m^2 \sin mx = -m^2 y$$

$$y_3 = -m^2 y_1, y_4 = -m^2 y_2 = m^4 y$$

$$y_5 = m^4 y_1, y_6 = -m^6 y$$

$$y_7 = -m^6 y_1, y_8 = -m^6 y_2 = m^8 y$$

$$\begin{vmatrix} y & y_1 & y_2 \\ y_3 & y_4 & y_5 \\ y_6 & y_7 & y_8 \end{vmatrix} = \begin{vmatrix} y & y_1 & -m^2 y \\ -m^2 y_1 & m^4 y & m^4 y_1 \\ -m^6 y & -m^6 y_1 & m^8 y \end{vmatrix}$$

$$= m^8 \begin{vmatrix} y & y_1 & m^2 y \\ -y_1 & m^2 y & m^2 y_1 \\ y & y_1 & m^2 y \end{vmatrix}$$

∴ The determinant is independent of  $m$  and  $x$ .

89)

Ans: a

Exp: NA

90)

Ans: d

$$a_1 + a_3 + a_5 + \dots a_{199} = \beta$$

$$a_2 + a_4 + a_6 + \dots a_{200} = \alpha$$

Exp:  $a_2 - a_1 + a_4 - a_3 + a_6 - a_5 \dots a_{200} - a_{199} = \alpha - \beta$

$$d + d + d \dots d = \alpha - \beta$$

$$d = \frac{\alpha - \beta}{100}$$

askIITians