

## BSNL Junior Telecom Officers-JTO 2009 Paper

## Technical Section - I

Question number 1-20 carry 1 mark each

- Q-meter works on the principle of
  - series resonance
  - parallel resonance
  - mutual inductance
  - self inductance
- The bridge circuit shown in Fig. Q2-I

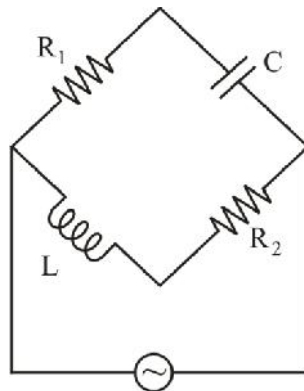

Fig. Q2-I

- cannot be balanced
  - can be balanced but the frequency of excitation must be known
  - can be balanced for only one frequency
  - can be balanced at any frequency
- Which one of the following statements is TRUE for an 'ideal' power diode?
    - Forward voltage drop is zero and reverse saturation current is non-zero.
    - Reverse recovery time is non-zero and reverse saturation current is zero.
    - Forward voltage drop is zero and reverse recovery time is zero.
    - Forward voltage drop is non-zero and reverse recovery time is zero.
  - In a MOSFET, the pinch-off voltage refers to
    - drain-to-source voltage at which drain-to-source current is zero
    - gate-to-source voltage at which gate-to-source current is zero
    - drain-to-source voltage at which gate-to-source current is zero

- (D) gate-to-source voltage at which drain-to-source current is zero
5. Which of the following statements is TRUE for DC switched mode power supply?
- (A) It cannot provide isolation between input and output as in rectifiers.  
(B) It cannot remove ripple as in DC switching mode regulators.  
(C) It has two stage conversions: dc-ac and ac-dc.  
(D) It is a type of chopper circuit
6. Which one of the following is a ceramic insulator?
- (A) Mica (B) Porcelain  
(C) Liquid costal (D) Synthetic fiber
7. Which one of the following represents a direct band-gap material?
- (A) Si (B) Ge (C) GaP (D) GaAs
8. Which one of the following statements is **NOT** true?
- (A) Rochelle salt exhibits ferroelectric property.  
(B) Spontaneous polarization is a characteristic property of ferroelectric material.  
(C) Spontaneous polarization of ferroelectric materials usually vanishes below ferroelectric Curie temperature.  
(D) Ferroelectric materials exhibit hysteresis effect.
9. Which one of the following diodes contains a metal-semiconductor junction?
- (A) Tunnel diode (B) Zener diode  
(C) Schottky diode (D) Gunn diode
10. Which one of the following statements is **NOT** true?
- (A) Ferrites can be used in transformer cores only at very low frequencies.  
(B) Ferrites are ferromagnetic material.  
(C) Ferrites show spontaneous magnetization below certain temperature.  
(D) DC resistivity of ferrites is many orders often higher than that of iron.
11. Which one of the following statements is **NOT** true?
- (A) In an intrinsic semiconductor, concentration of electrons in the conduction band is same as the concentration of holes in the valance band.  
(B) The probability of an energy state at the Fermi level being occupied by an electron is  $1/2$ .  
(C) Mobility of electrons is higher than that of holes.  
(D) In an n-type semiconductor, concentration of holes is equal to that of the intrinsic concentration.

12.  $ABCD$  parameters of a two-port network is defined as  $\begin{bmatrix} V_1 \\ I_1 \end{bmatrix} = \begin{bmatrix} A & B \\ C & D \end{bmatrix} \begin{bmatrix} V_2 \\ -I_2 \end{bmatrix}$ . If the port-2 is terminated by a resistance  $R_L$ , the admittance looking into the port-1 is

(A)  $\frac{C + DR_L}{A + BR_L}$       (B)  $\frac{CR_L + D}{AR_L + B}$       (C)  $\frac{CR_L + D}{A + BR_L}$       (D)  $\frac{C + DR_L}{AR_L + B}$

13. The phenomenon of injection electro-luminescence is the basis of working of

- (A) photodiodes      (B) light emitting diodes  
(C) phototransistors      (D) solar cells

14. A parallel combination of  $N$  resistances is connected across an ideal current source of  $I$  Amperes. The expression for the current in the  $k^{\text{th}}$  resistor  $R_k$  is

(A)  $\left( \frac{R_k}{R_1 + R_2 + \dots + R_N} \right) I$       (B)  $\left( \frac{\frac{1}{R_k}}{\frac{1}{R_1} + \frac{1}{R_2} + \dots + \frac{1}{R_N}} \right) I$   
(C)  $\left( \frac{\frac{R_k}{\frac{1}{R_1} + \frac{1}{R_2} + \dots + \frac{1}{R_N}}}{R_1 + R_2 + \dots + R_N} \right) I$       (D)  $\left( \frac{\frac{1}{R_k}}{R_1 + R_2 + \dots + R_N} \right) I$

15. In the circuit shown in Figure below, the voltage across the terminals A-B (in Volt) is

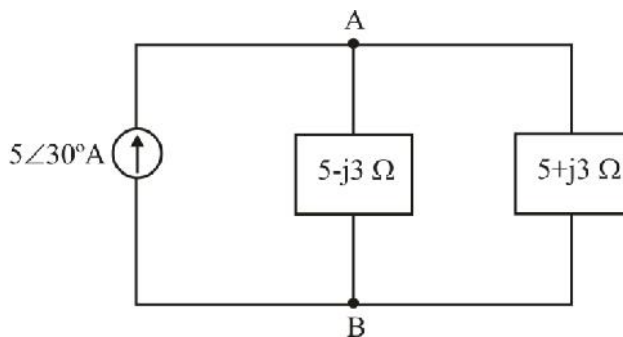
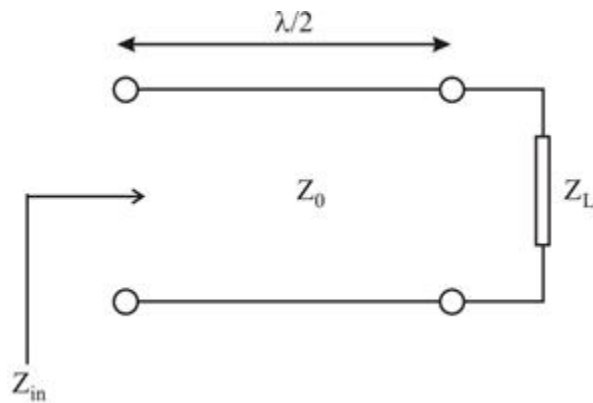

Fig. Q. 15-I

- (A)  $5\angle 30^\circ$       (B)  $12.5\angle 30^\circ$       (C)  $17\angle 30^\circ$       (D)  $25\angle 30^\circ$
16. A half wave (i.e.,  $\lambda/2$ ) lossless transmission line of characteristic impedance  $Z_0$  is terminated to a load of impedance  $Z_L$  as shown in the Figure below. The input impedance as seen at the other end is



- (A)  $\frac{Z_L}{Z_0}$                       (B)  $Z_L$                       (C)  $Z_L Z_0$                       (D)  $\frac{Z_L^2}{Z_0}$

17. A microstrip line has a strip width  $W$  and a grounded dielectric substrate of thickness  $d$  and relative permittivity  $\epsilon_r$ . Which one of the following statements is **NOT** true?

- (A) The effective dielectric constant  $\epsilon_{eff}$  satisfies  $1 < \epsilon_{eff} < \epsilon_r$   
 (B) The effective dielectric constant  $\epsilon_{eff}$  is a function of  $W/d$   
 (C) The characteristic impedance of the line is a function of  $W/d$   
 (D) The line can support pure TEM mode of wave propagation.

18. For a rectangular waveguide of internal dimensions  $a$  cm  $\times$   $b$  cm,  $a > b$ , the mode of wave propagation with the lowest cut off frequency is

- (A)  $TE_{01}$                       (B)  $TE_{10}$                       (C)  $TE_{11}$                       (D)  $TM_{11}$

19. The most appropriate value (in  $\Omega$ ) of the radiation resistance of a quarter wave monopole antenna is

- (A) 36.5                      (B) 50                      (C) 73                      (D) 120

20. Which one of the following is an active transducer?

- (A) Photo-voltaic cell                      (B) Strain gauge  
 (C) Photo-emissive cell                      (D) Synchro

**Question number 21-50 carry 2 marks each**

21. A 0.1 A ammeter having a resistance of  $10 \Omega$  is to be converted to a 1A ammeter by using a shunt resistance. Which one of the followings is the most appropriate shunt resistance?

- (A)  $0.1\Omega$                       (B)  $1.0 \Omega$                       (C)  $1.1 \Omega$                       (D)  $1.2 \Omega$

22. The forward voltage drop of a power diode is  $V_0 = 1.0$  V at the diode current  $I_D = 200$  A. Assuming the emission coefficient  $\eta = 2$  and thermal voltage  $V_T = 25.7$  mV, the reverse saturation current  $I_s$  (approximate) is  
 (A) 71.08  $\mu$ A                      (B) 51.20  $\mu$ A                      (C) 21.09  $\mu$ A                      (D) 41.09  $\mu$ A
23. In the circuit shown in figure, the voltage across 25 k $\Omega$  resistor is to be measured by using a voltmeter of sensitivity of 1 k $\Omega$ /V. The magnitude of percentage error in the measurement is

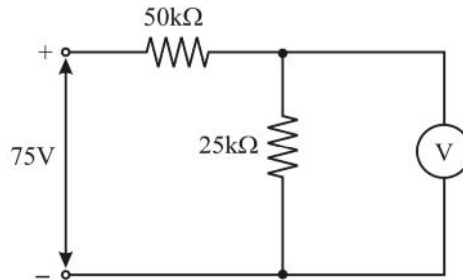

- (A) 10                                      (B) 20                                      (C) 30                                      (D) 40
24. Figure shows some load voltage versus load current plots. Which one of them is **NOT** valid for the classification of dc-dc converters?

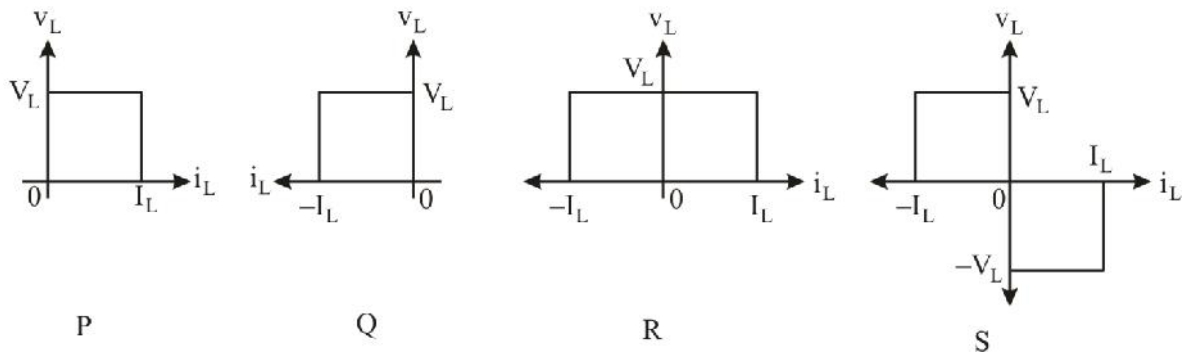

- (A) P                                      (B) Q                                      (C) R                                      (D) S
25. Two single phase inverters, one half-bridge and the other full-bridge, operating with equal inputs delivering power to identical loads. The ratio of, the power delivered, the first harmonic voltage and the total harmonic distortion, for full-bridge inverter to half-bridge inverter, respectively, are  
 (A) 4, 2, 1                              (B) 4, 2, 2                              (C) 4, 1, 1                              (D) 2, 1, 1

26. The correct match between Column A and Column B is

**Column A**

**Column B**

- |                    |                    |
|--------------------|--------------------|
| 1. DC Switch       | P. Boost converter |
| 2. Regulated DC-DC | Q. Cycloconverter  |
| 3. AC to AC        | R. Inverter        |
| 4. DC-to-AC        | S. MOSFET          |

- (A) 1-R, 2-Q, 3-P, 4-S                              (B) 1-S, 2-P, 3-Q, 4-R  
 (C) 1-P, 2-R, 3-Q, 4-S                              (D) 1-S, 2-Q, 3-P, 4-R

27. For the power transistor circuit shown in figure  $V_{CE(sat)} = 1.0 \text{ V}$ ,  $V_{BE(sat)} = 1.5 \text{ V}$  and  $\beta = 9$ . With an overdrive factor of 2.5, the required resistance  $R_B$  for saturation is

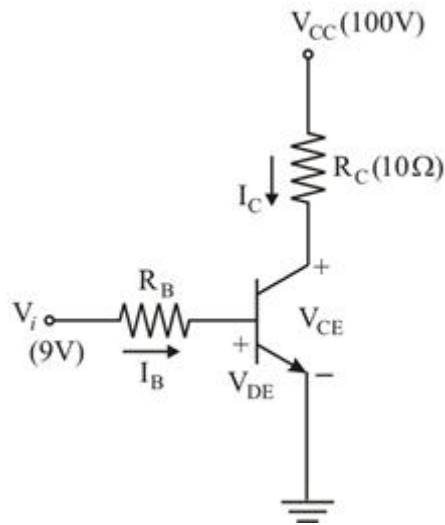

- (A)  $2.73 \Omega$                       (B)  $6.83 \Omega$                       (C)  $17 \Omega$                       (D)  $22.5 \Omega$
28. For a lossless air-filled cubical cavity of internal dimension 5 cm on each sides, the resonant frequency for the  $TE_{101}$  mode is
- (A)  $5\sqrt{2}$  GHz                      (B) 5 GHz                      (C)  $3\sqrt{2}$  GHz                      (D) 3 GHz
29. Which one of the following statements is NOT true?
- (A) For SCRs to be in the conduction state, the forward anode current must be greater than the latching current.
- (B) For SCRs to be in the forward blocking state, the forward anode current must be lower than the holding current.
- (C) When SCRs are in the conduction state, they can be turned off by applying suitable gate pulses.
- (D) When avalanche breakdown takes place, SCRs enter into the conduction state.
30. Consider two metallic wires  $W_1$  and  $W_2$ . They are made up of same material and each has circular cross section. The diameter of  $W_2$  is twice that of  $W_1$  and the length of  $W_2$  is four times that of  $W_1$ . Which one of the following statements is TRUE?
- (A) Resistance of  $W_1$  is half that of  $W_2$
- (B) Resistance of  $W_1$  is equal to that of  $W_2$
- (C) Resistance of  $W_1$  is twice that of  $W_2$
- (D) Resistance of  $W_1$  is eight times that of  $W_2$

31. A current of 1 A flows through a circular loop of superconducting wire having mean diameter of 1 m, cross section area of  $1 \text{ mm}^2$  and self inductance of  $4\pi \times 10^{-7} \text{ H}$ . The current reduces to 0.99 A after 1 year. The resistivity of the wire is
- (A)  $1.275 \times 10^{-26} \Omega\text{m}$  (B)  $1.275 \times 10^{-25} \Omega\text{m}$   
 (C)  $1.275 \times 10^{-24} \Omega\text{m}$  (D)  $1.275 \times 10^{-23} \Omega\text{m}$
32. An npn transistor is operating in CE mode and carries a collector current  $I_c = 1 \text{ mA}$  when the collector to emitter voltage  $V_{CE} = 1 \text{ V}$ . If the early voltage for the transistor is 74 V and base to emitter voltage  $V_{BE}$  is kept constant, at  $V_{CE} = 11 \text{ V}$  the collector current is
- (A) 15/19 mA (B) 1mA (C) 19/15 mA (D) 19/12 mA
33. Two parallel plate capacitors shown in figure (a) and (b) have capacitances  $C_1$  and  $C_2$ , respectively. If  $C_2 = 2 C_1$ , which one of the following relations is TRUE? (Neglect fringing effect)

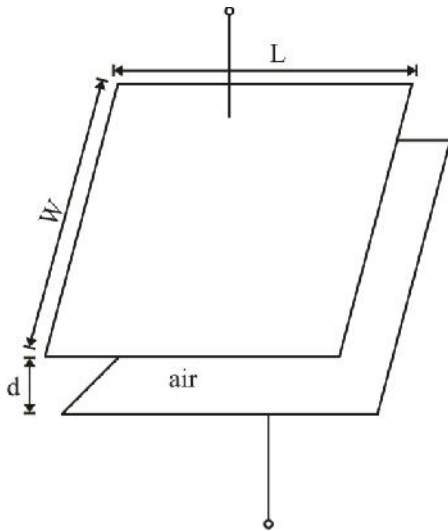

(a)

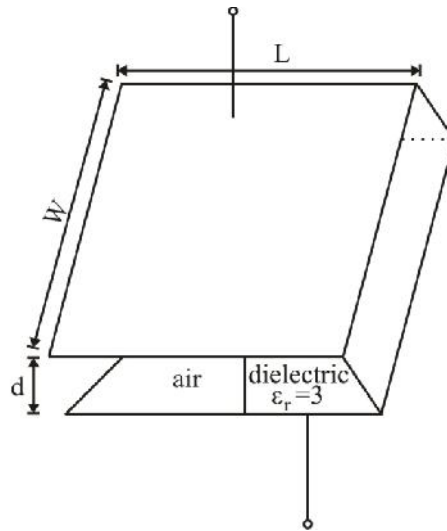

(b)

- (A)  $x = \frac{L}{4}$  (B)  $x = \frac{L}{2}$  (C)  $x = \frac{L}{3}$  (D)  $x = \frac{2L}{3}$
34. A doped semiconductor specimen has Hall coefficient  $3.6 \times 10^{-4} \text{ m}^3 \text{ C}^{-1}$  and the resistivity  $9 \times 10^{-3} \Omega\text{m}$ . Assuming single carrier conduction, the mobility and density of carriers in the specimen, respectively, are (approximately)
- (A)  $0.04 \text{ m}^2 \text{ V}^{-1} \text{ s}^{-1}$  and  $1.74 \times 10^{22} \text{ m}^{-3}$   
 (B)  $0.4 \text{ m}^2 \text{ V}^{-1} \text{ s}^{-1}$  and  $1.74 \times 10^{22} \text{ m}^{-3}$   
 (C)  $0.04 \text{ m}^2 \text{ V}^{-1} \text{ s}^{-1}$  and  $1.74 \times 10^{18} \text{ m}^{-3}$   
 (D)  $4.0 \text{ m}^2 \text{ V}^{-1} \text{ s}^{-1}$  and  $1.74 \times 10^{18} \text{ m}^{-3}$

35. If  $n$ ,  $n_i$ ,  $\mu_n$  and  $\mu_p$  respectively denote electron concentration, intrinsic concentration, mobility of electrons and mobility of holes, the minimum conductivity of a semiconductor sample occurs at

$$(A) n = n_i \sqrt{\frac{\mu_p}{\mu_n}}$$

$$(B) n = n_i \sqrt{\frac{\mu_n}{\mu_p}}$$

$$(C) n = n_i \sqrt{\mu_n \mu_p}$$

$$(D) n = n_i \sqrt{\mu_n + \mu_p}$$

36. GaAs has bandgap energy of 1.42 eV. The material would produce photon output at a wavelength of (Planck's constant =  $6.625 \times 10^{-34}$  J-s,  $q = 1.6 \times 10^{-19}$  C)

$$(A) 0.553 \mu\text{m}$$

$$(B) 0.653 \mu\text{m}$$

$$(C) 0.875 \mu\text{m}$$

$$(D) 0.953 \mu\text{m}$$

37. At a frequency of 1 GHz, the equivalent inductance between the terminals of a  $\lambda/8$  ( $\lambda$  represents wavelength) short-circuited lossless  $50 \Omega$  line is

$$(A) 5/\pi \text{ nH}$$

$$(B) 15/\pi \text{ nH}$$

$$(C) 25/\pi \text{ nH}$$

$$(D) 50/\pi \text{ nH}$$

38. For the circuit shown in figure, the transistor parameters are  $V_{BE} = 0.7$  V,  $\beta = 99$ . If  $V_c$  is to be set at 7.5 V, the required value (in  $k\Omega$ ) of  $R_B$  is

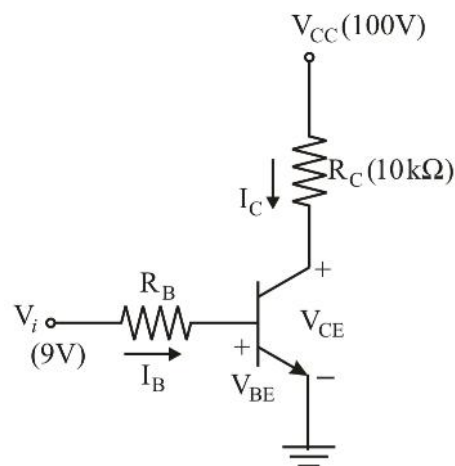

$$(A) 172$$

$$(B) 136$$

$$(C) 100$$

$$(D) 82$$

39. A quarter wave matching transformer is used to match a  $30 \Omega$  load to a line having characteristic impedance  $120 \Omega$ . The characteristic impedance of the quarter wave matching section is

$$(A) 50 \Omega$$

$$(B) 60 \Omega$$

$$(C) 120 \Omega$$

$$(D) 150 \Omega$$



40. If the average power delivered to a load terminated to a lossless transmission line is 75% of that of the incident power, the VSWR on the line is

- (A) 1/3                      (B) 1                      (C) 2                      (D) 3

41. For the circuit shown in figure, a value of R (in  $\Omega$ ), to which the voltage source would deliver 50% of the maximum deliverable power, is

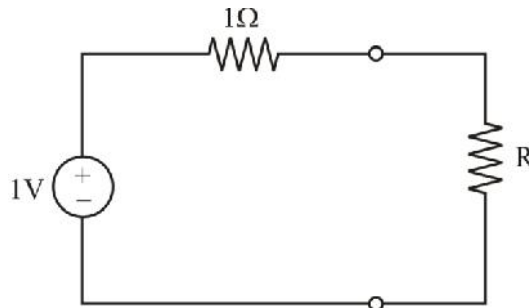

- (A) 1                      (B) 0.5                      (C) 0.25                      (D)  $3 - \sqrt{8}$

42. In the circuit shown in Figure (a), the current  $I_1 = 2$  A. The current  $I_2$  in figure (b) is

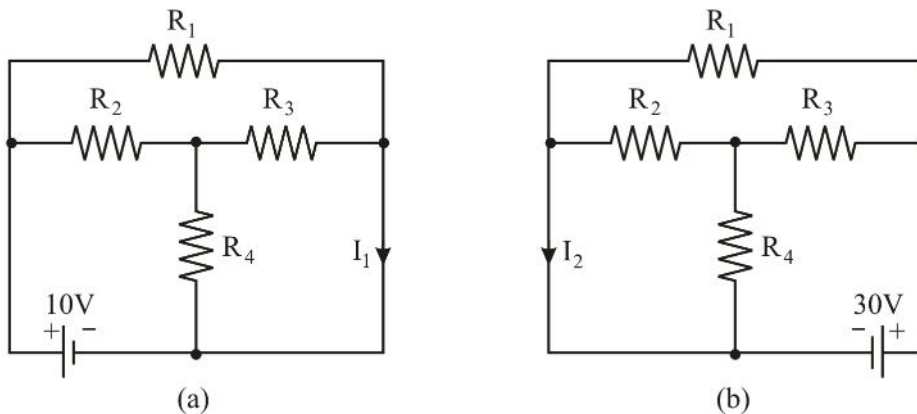

- (A) -6A                      (B) -4A                      (C) 4A                      (D) 6A

43. In the circuit shown in figure, the current I through  $2\ \Omega$  resistor is

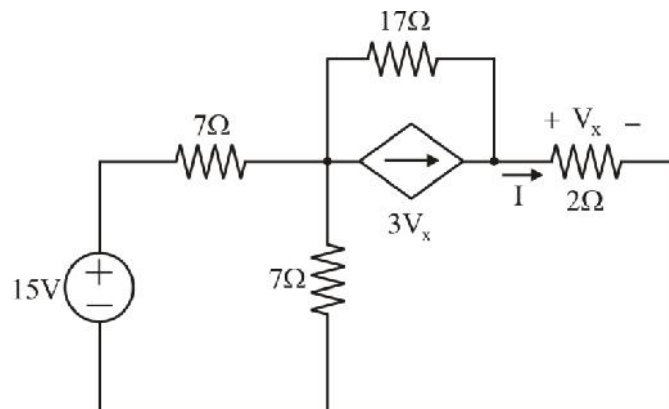

- (A) -94.34 mA                      (B) -70.34 mA                      (C) 70.34 mA                      (D) 94.34 mA

44. For the circuit shown in figure, the Thevenin's voltage and resistance at terminals A and B, respectively, are

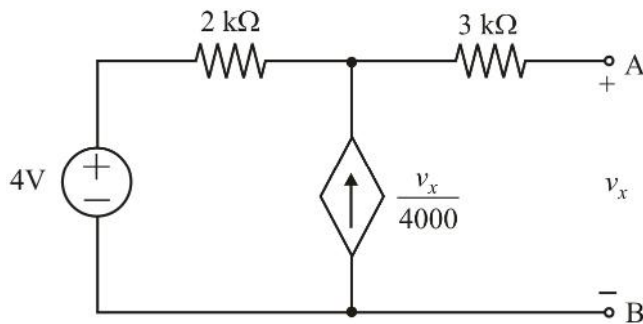

- (A) 8 V and 5 kΩ  
(B) 8 V and 10 kΩ  
(C) 4 V and 5 kΩ  
(D) 4 V and 10 kΩ
45. In the circuit shown in figure, the switch closes at  $t = 0$ . Assuming steady state condition for  $t = 0^-$ , the current  $i_L$  at  $t = 0.15$  sec is (approximately)

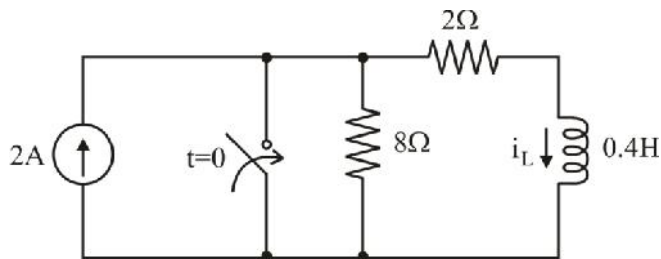

- (A) 0.04 A  
(B) 0.5 A  
(C) 0.76 A  
(D) 1.60 A
46. A PMMC instrument has a coil of dimensions  $10 \text{ mm} \times 10 \text{ mm}$  and the flux density in the air gap is  $2 \text{ mW/m}^2$ . The coil has 100 turns. If a current of 5 mA produces an angular deflection of  $90^\circ$ , the spring constant of the instrument is
- (A)  $\frac{2}{f} \times 10^{-8} \text{ N-m/rad}$   
(B)  $\frac{f}{2} \times 10^{-8} \text{ N-m/rad}$   
(C)  $f \times 10^{-8} \text{ N-m/rad}$   
(D)  $\frac{1}{f} \times 10^{-8} \text{ N-m/rad}$
47. In the circuit shown in figure, assume the diodes are ideal and the ammeter is an average indicating meter with zero internal resistance. The ammeter reading is

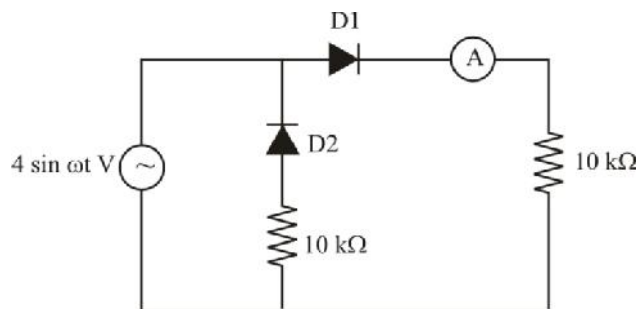

- (A)  $\frac{0.4}{f} \text{ mA}$   
(B)  $\frac{0.8}{f} \text{ mA}$   
(C)  $\frac{0.4}{\sqrt{2}} \text{ mA}$   
(D)  $\frac{0.8}{\sqrt{2}} \text{ mA}$

48. A capacitive transducer uses two quartz diaphragms of area  $550 \text{ m}^2$  each separated by a distance of  $3.7 \text{ mm}$ . A pressure of  $750 \text{ kN/m}^2$  applied to the top diaphragm produces a displacement of  $0.7 \text{ mm}$ . The capacity is  $390 \text{ pF}$  when no pressure is applied to the diaphragm. The value of the capacitance after the application of pressure of  $750 \text{ kN/m}^2$  is  
 (A)  $400 \text{ pF}$                       (B)  $451 \text{ pF}$                       (C)  $481 \text{ pF}$                       (D)  $500 \text{ pF}$
49. A thermistor has a resistance of  $500 \Omega$  at  $30^\circ\text{C}$  and has a temperature coefficient of  $-5 \Omega/^\circ\text{C}$ . This thermistor is used to measure the temperature of a system by the arrangement shown in figure. If the system temperature falls to  $20^\circ\text{C}$ , the  $V_{AB}$  measured by the voltmeter is

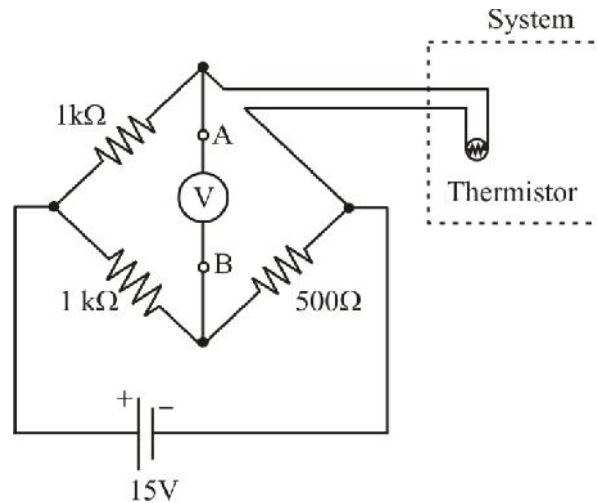

- (A)  $-10/29 \text{ V}$                       (B)  $-15/29 \text{ V}$                       (C)  $10/29 \text{ V}$                       (D)  $15/29 \text{ V}$
50. For the circuit shown in figure, if the current  $I = 3 \text{ A}$ , then the voltage  $V_2$  is  
 (A)  $2.5 \text{ V}$                       (B)  $5 \text{ V}$                       (C)  $8 \text{ V}$                       (D)  $10 \text{ V}$

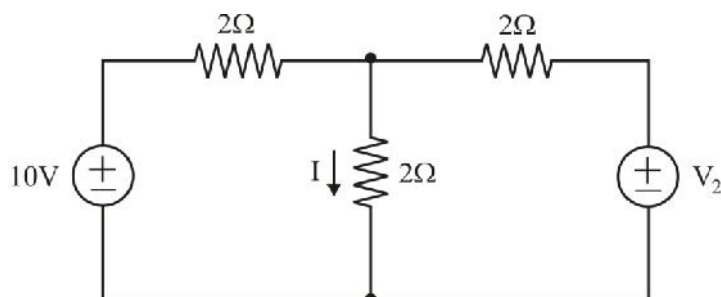

## Technical Section - II

### Question number 1-20 carry 1 mark each

1. Which one of the following statements is **NOT** true for a TWT?
  - (A) The interaction region usually consists of a slow wave helix structure.
  - (B) A static axial magnetic field keeps the electron beam focused.
  - (C) Continued interaction takes place between the waves on a traveling wave structure and the electron beam.
  - (D) TWT amplifiers are suitable only for narrowband microwave communication systems.
  
2. The minimized form of the Boolean expression  $F(A, B, C) = \pi M(0,2,3)$  is
  - (A)  $A + \bar{B}C$
  - (B)  $A + B\bar{C}$
  - (C)  $\bar{A}C + B$
  - (D)  $\bar{A}\bar{B}C + \bar{A}B$
  
3. Number of address lines required to address 8 k bytes of memory is
  - (A) 13
  - (B) 14
  - (C) 15
  - (D) 16
  
4. The standard binary code for alpha numeric characters is
  - (A) ASCII
  - (B) GRAY
  - (C) BCD
  - (D) Excess-3
  
5. The 2's complement of the binary number 1101100 in BCD is
  - (A) 12
  - (B) 13
  - (C) 14
  - (D) 15
  
6. In the op-amp circuit shown in figure, the voltage ratio  $V_0/V_i$  is

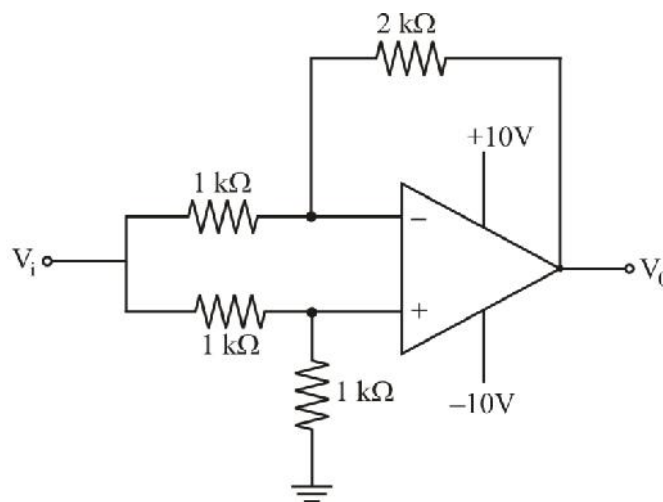

- (A) -2
  - (B) -1
  - (C) -0.5
  - (D) 0.5
  
7. For the Schmitt trigger circuit shown in figure. Assuming diodes and op-amp are ideal, the values of lower and upper threshold points of voltage transfer characteristics, respectively, are

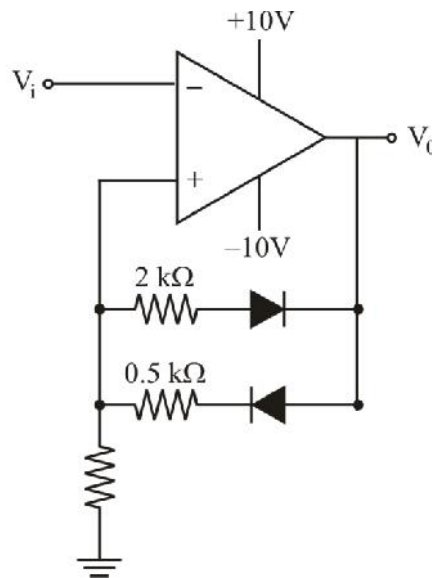

- (A)  $-8\text{ V}, +5\text{ V}$     (B)  $-5\text{ V}, +5\text{ V}$     (C)  $-5\text{ V}, +8\text{ V}$     (D)  $-8\text{ V}, +8\text{ V}$

8. Which one of the following Boolean expressions is NOT correct?

- (A)  $\overline{x+y} = \overline{x} \overline{y}$     (B)  $\overline{\overline{x+y}} = \overline{x} \overline{y}$     (C)  $\overline{\overline{\overline{xy}}} = \overline{x+y}$     (D)  $\overline{\overline{\overline{x+y}}} = \overline{x} \overline{y}$

9. A Boolean function can be expressed

- (A) as sum of maxterms or product of minterms  
 (B) as product of maxterms or sum of minterms  
 (C) partly as product of maxterms and partly as sum of minterms  
 (D) partly as sum of maxterms and partly as product of minterms

10. Among the following logic families, the one having the lowest power dissipation and highest noise margin is

- (A) Schottky TTL    (B) TTL  
 (C) ECL    (D) CMOS

11. The characteristic equation of a level triggered T flip-flop, with T as input and Q as output is

- (A)  $Q(n+1) = T\overline{Q} + \overline{T}Q$     (B)  $Q(n+1) = \overline{T}$   
 (C)  $Q(n+1) = Q$     (D)  $Q(n+1) = TQ + \overline{T}\overline{Q}$

12. The Nyquist plot of  $G(j\omega)H(j\omega)$  of a closed loop control system encloses the point  $(-1, j0)$  in GH-plane. The gain margin of the system in dB, is

- (A) greater than zero    (B) less than zero  
 (C) zero    (D) infinite

13. For the LTI system described by  $2\frac{d^2y(t)}{dt^2} + 3\frac{dy(t)}{dt} + 4y(t) = r(t) + 2r(t-1)$  and having zero initial conditions, the transfer function  $\frac{Y(s)}{R(s)}$  is
- (A)  $\frac{1+2e^s}{2s^2+3s+4}$       (B)  $\frac{2s^2+3s+4}{1+2e^s}$       (C)  $\frac{1+2e^{-s}}{2s^2+3s+4}$       (D)  $\frac{2s^2+3s+4}{1+2e^{-s}}$
14. An amplitude modulated double sideband suppressed carrier signal is given by  $[1+a_m \cos 2f_a t] \cos 2f_m t \cos 2f_c t$ , where  $f_c$  is the frequency of the carrier signal. The modulating signal is
- (A)  $a_m \cos 2f_a t$       (B)  $a_m \cos 2f_a t \cos 2f_m t$   
 (C)  $[1+a_m \cos 2f_a t] \cos 2f_m t$       (D)  $1+a_m \cos 2f_a t$
15. Which one of the following expressions represents a frequency modulated signal?
- (A)  $A_c \cos 2f [f_c t + m(t)]$       (B)  $\left[ 1 + \int_0^t m(\tau) d\tau \right] \cos 2f_c t$   
 (C)  $A_c m(t) \cos 2f_c t$       (D)  $A_c \cos 2f \left[ f_c t + \int_0^t m(\tau) d\tau \right]$
16. A binary pulse communication system transmits a normalized pulse  $p(t)$  over bit duration  $T_b$ . If the pulse  $p(t)$  has Fourier transform  $P(f)$ , the condition for zero intersymbol interference in the absence of noise is
- (A)  $\sum_{n=-\infty}^{\infty} P\left(f - \frac{n}{T_b}\right) = 1$       (B)  $\sum_{n=-\infty}^{\infty} P\left(f - \frac{n}{T_b}\right) = T_b$   
 (C)  $\sum_{n=-\infty}^{\infty} P\left(f - \frac{n}{T_b}\right) = \frac{1}{T_b}$       (D)  $\sum_{n=0}^{\infty} P\left(f - \frac{n}{T_b}\right) = T_b$
17. The magnitude response of an ideal equalizer for rectifying a distortion characterized by  $T \operatorname{sinc}(fT) e^{-jfT}$  is
- (A)  $|T \operatorname{sinc}(fT)|$       (B)  $T / \operatorname{sinc}(fT)$   
 (C)  $f / \operatorname{sinc}(fT)$       (D)  $\operatorname{sinc}(fT) / T$
18. If the minimum sampling frequency required to reconstruct a band limited analog signal from its samples is 8 kHz, the maximum frequency present in the signal is
- (A) 16 kHz      (B)  $\geq 16$  kHz      (C) 4 kHz      (D)  $> 4$  kHz

19. Which one of the following statements is NOT true?
- (A) The two cavity klystron tube is used as an amplifier.
  - (B) A reflex klystron uses only a single cavity and operates as an oscillator.
  - (C) In klystron tubes, the bunching of electrons is caused by velocity modulation.
  - (D) Klystrons belong to the category of crossed-field tubes.
20. In a microprocessor, the program counter points to the address location from where the
- (A) current byte is to be fetched
  - (B) next byte is to be fetched
  - (C) next byte is to be stored
  - (D) current byte is to be added

**Question number 21-50 carry 2 marks each**

21. A microwave link operates under free space conditions at a frequency of 1 GHz and uses identical antennas at the transmitter and the receiver ends. The transmitter and the receiver are separated by a distance of 30 km. If  $-30$  dBm power is to be received when the transmitted power is 1 W, the antenna gain should be
- (A)  $100 f$                       (B)  $200 f$                       (C)  $300 f$                       (D)  $400 f$
22. In connection with memory mapped I/O which one of the following statements is NOT true?
- (A) The processor treats an interface register as a part of the memory system.
  - (B) It reduces the memory space available.
  - (C) The processor cannot manipulate I/O data residing in interface registers with the same instructions that are used to manipulate memory location.
  - (D) Arithmetic or logical operation can be directly performed with I/O data.
23. After execution of the following C program, the value of the sum printed is

```

Main( )
{
    int i, n;
    float x, dx, sum;
    sum = 0;
    x = 2;
    for (i = 1; i <= 100; i++)
    {
        dx = x * (i - 1);
        sum = sum + dx;
        x = 2 * x;
        if (sum > x)
            break;
    }
    printf( "%f" , sum );
end;
}

```

- (A) 68.0                      (B) 20.0                      (C) 16.0                      (D) 4.0

24. If selection sort takes 3 ms to run an array of 200 elements, for a similar array of 4000 elements the selection sort is expected to take
- (A) 1.2 s                      (B) 600 ms                      (C) 300 ms                      (D) 60 ms
25. In a stack based processor organization, postfix notation is used for evaluating arithmetic expressions. The postfix expression  $ABC*/D-EF/+$  for  $A = 6, B = 2, C = 3, D = 3, E = 4$  and  $F = 2$  evaluates to
- (A) 0                              (B) 1                              (C) 2                              (D) 3
26. In a 8085 microprocessor system, the active low chip select ( $\overline{CS}$ ) signal is generated by passing address lines  $A_{15}, \dots, A_{10}$  through a 6 inputs NAND gate. For selecting the address range  $CC00$  to  $CFFF$ , the inputs to the NAND gate are
- (A)  $A_{10}, A_{11}, \overline{A_{12}}, \overline{A_{13}}, A_{14}, A_{15}$                               (B)  $\overline{A_{10}}, \overline{A_{11}}, A_{12}, A_{13}, \overline{A_{14}}, \overline{A_{15}}$   
 (C)  $A_{10}, A_{11}, \overline{A_{12}}, A_{13}, A_{14}, A_{15}$                               (D)  $A_{10}, A_{11}, A_{12}, A_{13}, A_{14}, A_{15}$
27. In the context of 8085 microprocessor, the correct matching combination between Column A and Column B is

<u>Column A</u>	<u>Column B</u>
P. ALE	1. Rotate accumulator left
Q. PSW	2. Compare with accumulator
R. CMA	3. Program status word
S. RLC	4. Address latch enable
	5. Program stack word
	6. Arithmetic logic enabled
	7. Complement accumulator
	8. Rotate accumulator left through carry
(A) P-6, Q-5, R-2, S-8	(B) P-4, Q-3, R-2, S-8
(C) P-4, Q-3, R-7, S-1	(D) P-6, Q-5, R-7, S-1

28. The content of the memory location 2070 H after the execution of the following 8085 program is

```

LXIB 2070H
MVI A, 8FH
MVI C, 68H
SUB C
ANI 0FH
STAX B
HLT

```

- (A) 0.4H                      (B) 07 H                      (C) 09 H                      (D) 0F H



29. A 8085 microprocessor program uses all available Jump instructions, each only once. For this program, the total memory (in Bytes) occupied by the Jump instructions is  
 (A) 30            (B) 27            (C) 24            (D) 18
30. The circuit shown in figure oscillates at an angular frequency of  $\omega$  at a particular R. The values of  $\omega$  (in rad/sec) and R (in  $k\Omega$ ), respectively, are

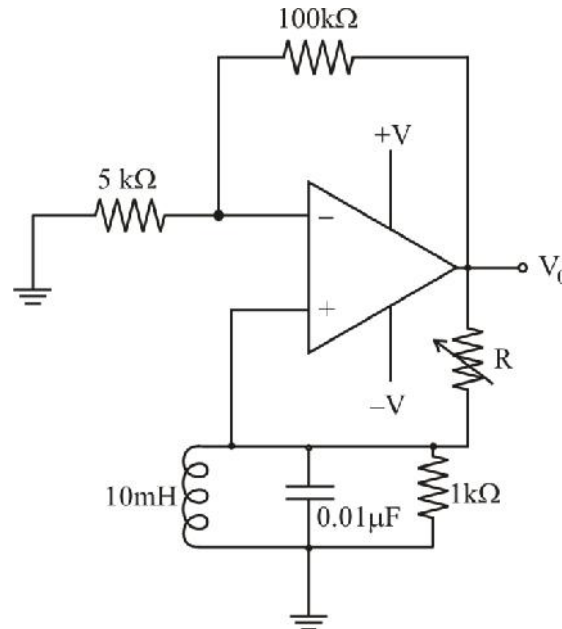

- (A)  $10^5$  and 20            (B)  $2 \times 10^5$  and 20            (C)  $2 \times 10^5$  and 10            (D)  $10^5$  and 10
31. A combinational circuit accepts a 2 bit binary number and outputs its square in binary. To design this circuit using a ROM, the minimum size of ROM required is  
 (A)  $2 \times 2$             (B)  $4 \times 2$             (C)  $4 \times 4$             (D)  $8 \times 4$
32. In the op-amp circuit shown in the figure below. Assume the diode current follows the equation  $I = I_s e^{V/V_T}$ . If  $V_0 = V_{0_1}$  for  $V_i = 2V$  and  $V_0 = V_{0_2}$  for  $V_i = 4V$ , the relation between  $V_{0_1}$  and  $V_{0_2}$  is

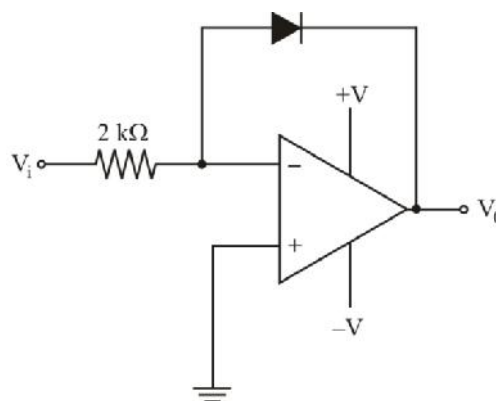

- (A)  $V_{0_2} = V_{0_1} \sqrt{2}$             (B)  $V_{0_2} = V_{0_1} e^2$   
 (C)  $V_{0_2} = V_{0_1} \ln 2$             (D)  $V_{0_2} = V_{0_1} + V_T \ln 2$

33. In the 2-stage amplifier circuit shown in figure, if the transconductances of transistor  $Q_1$  and transistor  $Q_2$  are  $g_{m1}$  and  $g_{m2}$  respectively, the overall transconductance  $g_{m0} = i_0/V_i$  of the amplifier is

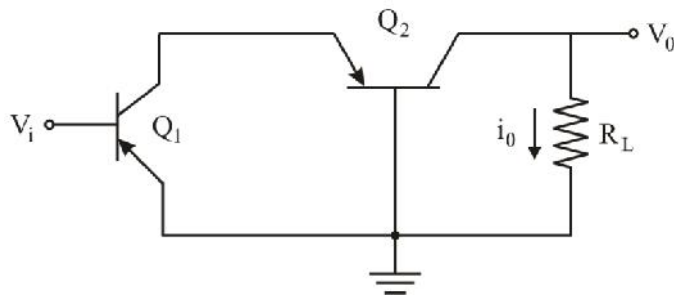

- (A)  $g_{m0} \approx g_{m1}$  (B)  $g_{m0} \approx g_{m2}$   
 (C)  $g_{m0} = g_{m1} + g_{m2}$  (D)  $g_{m0} = g_{m1} - g_{m2}$
34. For the system with  $G(s)H(s) = \frac{K(s+4)}{s(s+1)}$ , the breakaway points in the root-loci plot approximately are

- (A)  $-7.46, -1$  (B)  $-0.54, -1$  (C)  $-7.46, -0.54$  (D)  $7.46, 0.54$

35. For the circuit shown in figure, the p-channel JFET transistor parameters are  $I_{DSS} = 6 \text{ mA}$  and  $V_p = 4 \text{ V}$ . The source-to-drain voltage  $V_{SD}$  and the region of operation of the transistor, respectively, are

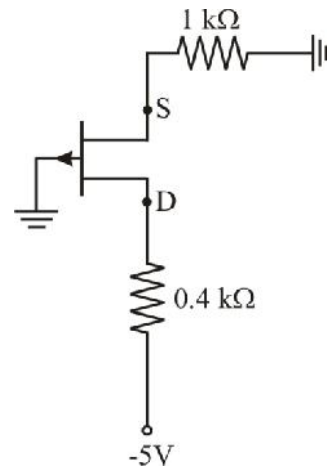

- (A) 2.09 V and active region  
 (B) 2.09 V and saturation region  
 (C) 2.47 V and active region  
 (D) 2.47 V and saturation region

36. For the truth table given in figure, the minimized Boolean expression is

Input			Output
X	Y	Z	P
0	0	0	1
0	0	1	0
0	1	0	0
0	1	1	1
1	0	0	0
1	0	1	1
1	1	0	1
1	1	1	0

- (A)  $P = xyz + \overline{xy}z + x\overline{y}z + x\overline{y}\overline{z}$  (B)  $P = x \oplus y \oplus z$   
 (C)  $P = \overline{x(y \oplus z)} + x(y \oplus z)$  (D)  $P = x \oplus \overline{y} \oplus z$

37. For a linear system having the characteristic equation  $s^4 + s^3 + 2s^2 + 2s + 3 = 0$ , the number of roots in the right-half of s-plane is  
 (A) 4 (B) 3 (C) 2 (D) 1
38. The Boolean function  $F(A, B, C) = \Pi(0, 2, 4, 7)$  is to be implemented using a  $4 \times 1$  multiplexer shown in figure. Which one of the following choices of inputs to multiplexer will realize the Boolean function?

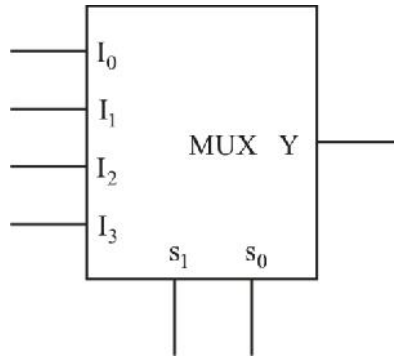

- (A)  $(I_0, I_1, I_2, I_3, s_1, s_0) = (1, 0, \bar{A}, A, C, B)$   
 (B)  $(I_0, I_1, I_2, I_3, s_1, s_0) = (1, 0, \bar{A}, A, B, C)$   
 (C)  $(I_0, I_1, I_2, I_3, s_1, s_0) = (0, 1, \bar{A}, A, C, B)$   
 (D)  $(I_0, I_1, I_2, I_3, s_1, s_0) = (0, 1, A, \bar{A}, B, C)$
39. An edge triggered synchronous binary counter is provided with a clock ( $CLK$ ) and control inputs; active low clear ( $\overline{CLR}$ ), active high load ( $L$ ) and active high count ( $C$ ). The correct matching combination between Column A and Column B is

Column A	Column B
1. $(CLK, \overline{CLR}, L, C) = (\uparrow, 1, 1, X)$	P. No change
2. $(CLK, \overline{CLR}, L, C) = (\uparrow, 1, 0, 1)$	Q. Load inputs
3. $(CLK, \overline{CLR}, L, C) = (X, 0, X, X)$	R. Count next binary state
4. $(CLK, \overline{CLR}, L, C) = (X, 1, 0, 0)$	S. Clear outputs

Where X = don't care

- (A) 1-Q, 2-R, 3-S, 4-P (B) 1-P, 2-Q, 3-R, 4-S  
 (C) 1-Q, 2-R, 3-P, 4-S (D) 1-P, 2-Q, 3-S, 4-R
40. A 5-bit serial adder is implemented using two 5-bit shift registers, a full adder and a D flip-flop. The two binary words to be added are 11011 and 11011. The sum of the two numbers is stored in one of the shift registers and the carry in the D flip-flop. Assuming that the D flip-flop is set initially, the content of the sum shift register and the D flip-flop, respectively, are  
 (A) 10111 and 0 (B) 11011 and 1  
 (C) 11101 and 0 (D) 10111 and 1

41. For the flow diagram shown in figure, the transfer function  $\frac{Y(s)}{R(s)}$  is

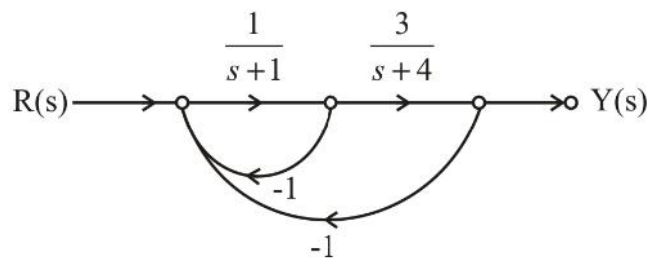

- (A)  $\frac{3}{s^2 + 6s + 11}$       (B)  $\frac{3}{s^2 + 5s + 4}$       (C)  $\frac{3}{s^2 + 6s + 8}$       (D)  $\frac{-3}{s^2 + 6s + 11}$

42. The compensated system shown in figure has a phase margin of  $60^\circ$  at the crossover frequency of 1 rad/sec. The value of K is

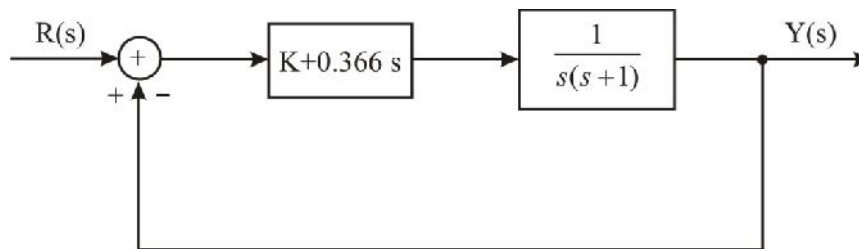

- (A) 0.366      (B) 0.732      (C) 1.366      (D) 2.732
43. A time division multiplex system samples 96 voice channels at a rate of 8 kHz and encodes into 8 bits per sample. If one synchronization bit per frame is added, the transmitted data rate (Mbps) is
- (A) 6.208      (B) 6.152      (C) 6.144      (D) 0.768
44. A geostationary satellite located at 36,000 km from the surface of the earth. The uplink free space loss is 1.583 dB higher than the downlink free space loss. If the downlink frequency is 10 GHz, the uplink free space loss (in dB) is
- (A) 10.25      (B) 20.5      (C) 102.5      (D) 205
45. In a uniform quantizer, the quantization noise is
- (A) independent of the number of levels of the quantizer  
 (B) proportional to square of the peak-to-peak voltage range of the quantizer  
 (C) independent of the peak-to-peak voltage range of the quantizer  
 (D) proportional to square of the number of levels of the quantizer
46. In a digital communication system, the transmitted pulse is shown in figure. The matched filter output at the sampling instant (i.e.,  $t = 1$  sec) is

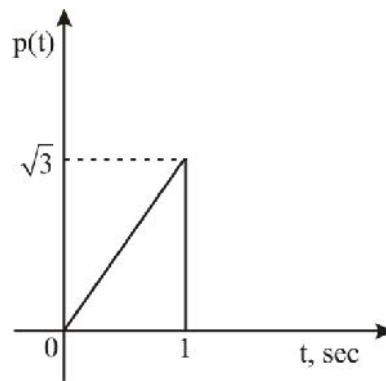

- (A)  $\frac{\sqrt{3}}{2}$                       (B) 1                      (C)  $\frac{1}{2}$                       (D)  $\frac{1}{6}$

47. An optical link uses a fiber having a power loss of 1 dB/km. A typical photo detector has responsivity 0.5 A/W. If the link is 3 km long and the detector is required to produce a current of 25  $\mu$ A, the required transmitted power is

- (A) 0 dBm                      (B) -10 dBm                      (C) -30 dBm                      (D) -50 dBm

48. For the directional coupler shown in figure, the coupling is 20 dB and the directivity is 30 dB. If 10 W power is incident in port-1, power out of port-4 is

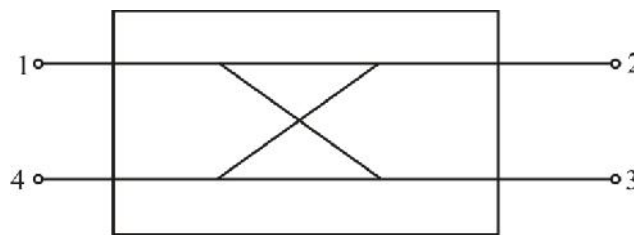

- (A) 0.1 mW                      (B) 1 mW                      (C) 0.01 W                      (D) 0.1 W

49. In a microwave measurement with slotted rectangular waveguides, the distance between successive minima is found to be 2.5 cm. If the measurement has been carried out at a frequency of 10 GHz and the guide operates in TE<sub>10</sub> mode, the

cut off frequency  $f_{c_{10}}$  for the guide is

- (A) 6 GHz                      (B) 8 GHz                      (C) 10 GHz                      (D) 12 GHz

50. An antenna having a directivity of 2 at a frequency of 300 MHz will have a maximum effective aperture of

- (A)  $\frac{1}{8f}$  m<sup>2</sup>                      (B)  $\frac{1}{4f}$  m<sup>2</sup>  
 (C)  $\frac{1}{2f}$  m<sup>2</sup>                      (D)  $\frac{1}{f}$  m<sup>2</sup>

**General Ability Test Section - III****All questions carry 1 mark each**

1. Chandrayaan-I, India's first mission to the moon, has 11 scientific instruments that are being released on the surface of the moon. These instruments are together known as  
(A) Moon Impact Probes (B) Terrain Mapping Cameras  
(C) Scientific Payloads (D) Spectrometers
2. The World Wide Web was invented by  
(A) Tim Berners-Lee (B) Narayanmurthy  
(C) Sabeer Bhatia (D) Charles Babbage
3. How many diagonals does a quadrilateral have?  
(A) One (B) two (C) four (D) eight
4. ISO 14000 standards deal with  
(A) quality management (B) production management  
(C) human resource management (D) environmental management
5. Which Indian politician's autobiography is titled *The Story of My Life*?  
(A) Morarji Desai (B) Mahatma Gandhi  
(C) Lal Krishna Advani (D) Atal Behari Vajpayee
6. The phrase 'through thick and thin' means  
(A) big and small (B) thin and fat  
(C) large object (D) under all conditions
7. Picturesque means  
(A) photogenic (B) simple (C) simulating (D) ugly
8. Diligent means  
(A) intelligent (B) energetic (C) modest (D) industrious

9. The opposite of miserly is  
(A) spendthrift (B) generous (C) liberal (D) charitable
10. The opposite of ingratitude is  
(A) sympathy (B) reward  
(C) thankfulness (D) stimulation
11. The appropriate missing word in the blank space in the sentence "I prefer coffee \_\_\_\_\_ tea." is  
(A) than (B) over (C) for (D) to
12. The appropriate missing word in the blank space in the sentence "Many relatives attended \_\_\_\_\_ him during his illness."  
(A) of (B) on (C) for (D) with
13. The article required before the word "one-eyed" in the sentence "There was \_\_\_\_\_ one-eyed beggar by the multiplex." is  
(A) the (B) a (C) an (D) nil
14. The article required before the word University in the sentence "She met Professor Shah at \_\_\_\_\_ University." is  
(A) a (B) an (C) the (D) nil
15. Which one is the correct sentence amongst the following sentences?  
(A) Mr. Gupta, accompanied by his friends, were assembled on the lawns.  
(B) Mr. Gupta, accompanied by his friends, are assembled on the lawns.  
(C) Mr. Gupta, accompanied by his friends, assembled on the lawns.  
(D) Mr. Gupta, accompanied by his friends, have assembled on the lawns.
16. Who was the first woman to be elected as the President of the Indian National Congress?  
(A) Sarojini Naidu (B) Sonia Gandhi  
(C) Indira Gandhi (D) Annie Besant
17. Which political leader delivered the famous 'I have a dream' speech?  
(A) Jawaharlal Nehru (B) Winston Churchill  
(C) Martin Luther King (D) Rabindranath Tagore
18. Who established the organization 'Khudai Khidmatgar'?

- (A) Hyder Ali (B) Gopal Krishna Gokhale  
 (C) Maulana Abul Kalam Azad (D) Khan Abdul Ghaffar Khan
19. Analgesics are drugs used to prevent or relieve  
 (A) aches and pain (B) fever and high body temperature  
 (C) hormone deficiency (D) stress and anxiety
20. The abbreviation CD stands for  
 (A) Circular Disc (B) Computer Device  
 (C) Compact Disc (D) Code-Demodulator

**To access and download BSNL JTO Papers & Solutions, visit at our website.**

[BSNL-JTO 2009 question paper.](#)

[BSNL-JTO 2009 detailed Solutions.](#)

[BSNL-JTO 2005 question paper.](#)

[BSNL-JTO 2005 detailed Solutions.](#)

[BSNL-JTO 2002 question paper.](#)

[BSNL-JTO 2002 detailed Solutions.](#)

[BSNL-JTO 2001 question paper.](#)

[BSNL-JTO 2001 detailed Solutions.](#)

To buy these books online email your Name, Phone at  
[eiidelhi@gmail.com](mailto:eiidelhi@gmail.com) Ph. 0-9990657855

