

Sl. No.

0064724

A-HUF-P-VEA

**ELECTRONICS AND  
TELECOMMUNICATION ENGINEERING**

**Paper I  
(Conventional)**

*Time Allowed : Three Hours*

*Maximum Marks : 200*

**INSTRUCTIONS**

*Please read each of the following instructions  
carefully before attempting questions.*

*There are SEVEN questions in the paper.*

*Candidates are required to attempt  
FIVE questions in all.*

*Question No. 1 is compulsory.*

*Out of the remaining SIX questions, attempt any  
FOUR questions.*

*The number of marks carried by a question/part  
is indicated against it.*

*Unless otherwise mentioned, symbols and notations  
have their usual standard meanings.*

*Assume suitable data, if necessary and indicate  
the same clearly.*

*Neat sketches are to be drawn to illustrate answers,  
wherever required.*

*All parts and sub-parts of a question are to be  
attempted together in the answer book.*

*Attempts of questions shall be counted in sequential  
order. Unless struck off, attempt of a question shall  
be counted even if attempted partly.*

*Answers must be written in ENGLISH only.*

*Any page or portion of the page left blank in the  
answer book must be clearly struck off.*

**Values of constants which may be required :**

Electron charge	= $-1.6 \times 10^{-19}$ Coulomb
Free space permeability	= $4\pi \times 10^{-7}$ Henry/m
Free space permittivity	= $(1/36\pi) \times 10^{-9}$ Farad/m
Velocity of light in free space	= $3 \times 10^8$ m/sec
Boltzman constant	= $1.38 \times 10^{-23}$ J/K
Planck's constant	= $6.626 \times 10^{-34}$ J-s

1. (a) Distinguish between zener and Avalanche breakdown phenomenon. Determine the temperature co-efficient of a 5 V zener (Rated  $25^\circ\text{C}$  value), if the nominal voltage drops to 4.8 V at temperature of  $100^\circ\text{C}$ . 5
- (b) An  $n$ -type semiconductor Si containing  $10^{16}$  phosphorous atoms per  $\text{cm}^3$  is doped with  $10^{17}$  Boron atoms/ $\text{cm}^3$ . Calculate the electrons and hole concentration. Assume  $ni = 10^{10}/\text{cm}^3$ . 5
- (c) Consider the circuit shown below in which  $C = 0.5 \text{ F}$  and  $L = 0.5 \text{ H}$ .  
Suppose  $v_{in}(t) = 20 e^{-2t}$  and all initial conditions are zero. Calculate  $v_c(t)$ .

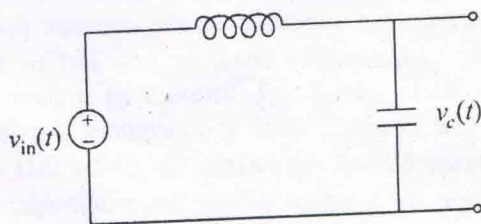

- (d) Clearly distinguish between
- (i) ionic and covalent bonding
  - (ii) Reach through and punch through phenomenon

5

- (e) Show that if  $R_H$  is the Hall co-efficient and  $\sigma$  is the conductivity of a metal then the drift mobility of the conduction electron is given by

$$\mu_d = |\sigma R_H| \quad 5$$

- (f) A 0–1 mA meter with internal resistance of  $5 \Omega$  is given. How would the range of the meter be extended to measure up to 10 mA ?

5

- (g) Consider the following figure :

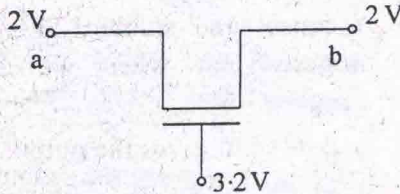

Given  $\frac{\mu_n C_{ox} \cdot W}{L} = \frac{1 \text{ mA}}{V^2}$  and  $V_{th} = 1 \text{ V}$ .

Calculate the resistance ( $r_{ds}$ ) between  $a$  and  $b$ ,



5

- (h) Estimate the energy of a blue photon which has a wavelength of 450 nm.

5



2. (a) Let  $G$  represent a causal system that is described by the following differential equation;

$$\frac{dy(t)}{dt} + y(t) = \frac{dx(t)}{dt} - x(t)$$

where  $x(t)$  and  $y(t)$  are input and output of the system respectively. Determine the output  $y_1(t)$  of  $G$  when the input  $x_1(t)$  is defined as

$$x_1(t) = \begin{cases} e^{-2t}; & t \geq 0 \\ 0; & \text{otherwise} \end{cases} \quad 5$$

- (b) A causal and stable LTI system  $S$  has the property that when we apply the input;

$$\left(\frac{4}{5}\right)^n u(n), \text{ it gives the output } n \left[\frac{4}{5}\right]^n u(n).$$

- (i) Determine the transfer function  $H(e^{j\omega})$  for the system. 5

- (ii) Determine the difference equation relating any input  $x[n]$  and the corresponding output  $y[n]$ . 5

- (c) The amplitude spectrum of a signal  $x(t)$  is given in the following figure. Determine the signal  $x(t)$  and plot it.

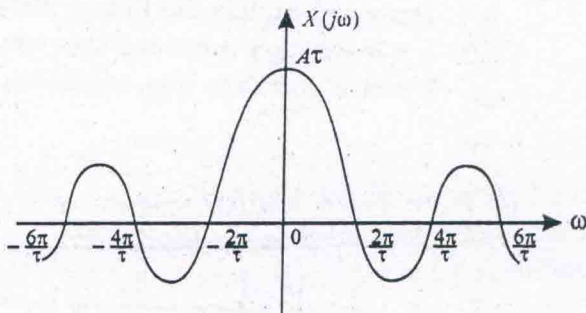

10

- (d) What is  $z$ -transform? Find the  $z$ -transform of

$$F(s) = \frac{1}{s^2}. \quad 5$$

- (e) A discrete time system, with input  $u(k)$ , has a transfer function given by

$$G(z) = \frac{z - 0.8}{z^2 - 1.3z + 0.42}$$

Compute the unit-step response of the system assuming all initial conditions to be zero. 10

3. (a) A sample of germanium is doped to the extent of  $10^{14}$  atoms/cm<sup>3</sup> and  $7 \times 10^{13}$  acceptor atoms/cm<sup>3</sup>. At the temperature the resistivity of pure (intrinsic) germanium is  $60 \Omega \text{ cm}$ . If the applied electric field is  $2 \text{ V/cm}$ , find the total conduction current density. 10

- (b) What are SCRs? Draw the symbol and its V-I characteristics. Explain its operation. 5
- (c) Draw and explain the Energy Band diagram of a  $p-n$  junction semiconductor under Forward, Reverse and Zero bias conditions. 10
- (d)

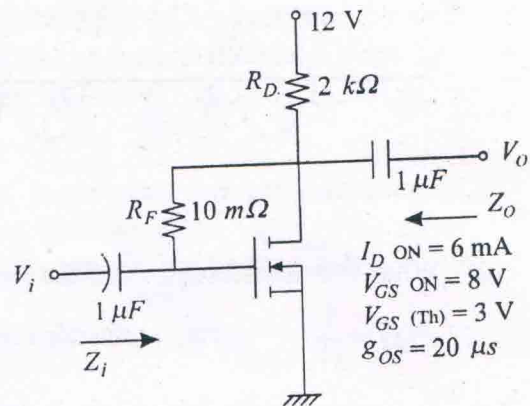

For the E-MOSFET of above figure, Determine;

- (i)  $g_m$
- (ii) find  $r_d$
- (iii) calculate  $z_i$  with and without  $r_d$  and compare result
- (iv) find  $z_o$  with and without  $r_d$  and compare result
- (v) find  $A_v$  with and without  $r_d$  and compare result

Given that  $k = 0.24 \times 10^{-3}\text{ A/V}^2$

$$V_{GSQ} = 6.4\text{ V}; I_{DQ} = 2.75\text{ mA.}$$

15

X (a) Write the word statements for Maxwell's equations along with the mathematical equations. 5

(b) Show that the plasma frequency for electrons can be expressed in simple numerical form i.e.

$f_p = 9 \sqrt{N}$  where  $f_p$  is in Hz and  $N$  is the electron density in electrons/m<sup>3</sup>.

What is  $f_p$  for the ionosphere, if  $N = 10^{12}$ . 10

(c) Find the expression for the magnetic flux density in the centre of a circular current loop as shown in the following figure.

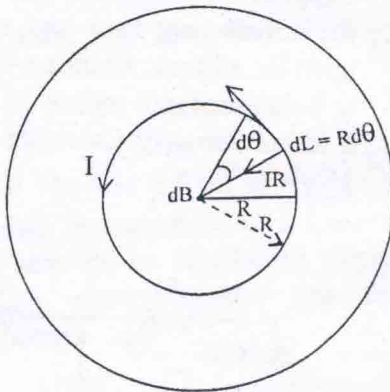

10

(d) What is maximum allowed spacing  $d_{\max}$  between the parallel plate wave-guide plates? If the plate spacing is 2.1 cms and  $f = 10$  GHz which  $TE_n$  and  $TM_n$  modes will propagate?

15



5. (a)

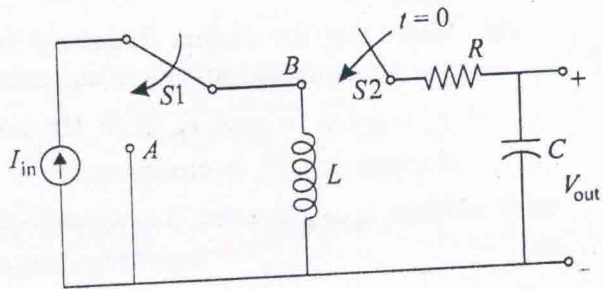

In the ckt shown above  $L = 0.25 \text{ H}$ ,  $C = 0.25 \text{ F}$ ,  $R = 2 \Omega$  and  $I_{in}(t) = 10 \text{ A (dc)}$  for all time. Suppose that switch  $S1$  has been in position  $B$  for a very long time and switch  $S2$  has been open for all time. At time  $t = 0$  switch  $S1$  moves to position  $A$  and switch  $S2$  closes on position  $B$  instantaneously. Calculate :  
 $V_{out}(t)$  at  $t = 0.5$  seconds if  $V_{out}(0^-) = 0$ . 15

(b)

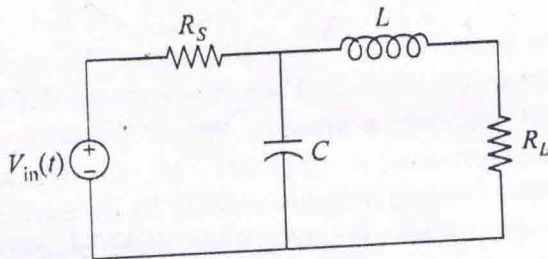

In the ckt given above  $R_L = 5 \Omega$  and  $R_S = 10 \Omega$ . If  $V_{in}(t) = 10 \cos(10t)u(t) \text{ V}$ . Calculate the value of  $L$  and  $C$  that leads to maximum power transfer to the load at the frequency determined by the input cosine. 15



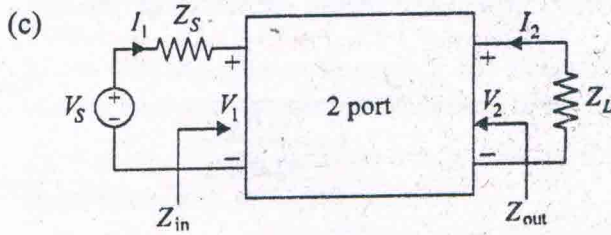

In the ckt shown above, the terminated 2 port having general  $h$ -parameters are

$$\begin{bmatrix} V_1 \\ I_2 \end{bmatrix} = \begin{bmatrix} h_{11} & h_{12} \\ h_{21} & h_{22} \end{bmatrix} \begin{bmatrix} I_1 \\ V_2 \end{bmatrix}$$

Calculate (i) the gain  $GV_2 = \frac{V_2}{V_1}$

(ii) Assuming  $h_{11} = 2/s$ ,  $h_{12} = 2$ ,  $h_{21} = 0.5$  and  $h_{22} = s$ . Calculate  $z_{in}(s)$  in ohms. 10

6. (a) Explain the operation of a Quartz-crystal with the help of its equivalent circuit. A typical 1 MHz quartz crystal has the following properties

$f_s = 1 \text{ MHz}$	] Where	$f_s =$ Mechanical Resonant Frequency
$f_a = 1.0025 \text{ MHz}$		$f_a =$ Anti Resonant Frequency
$C_o = 5 \text{ pF}$		$C_o =$ Parallel plate capacitance between the electrodes
$R = 20 \ \Omega$		

What are  $C$  and  $L$  in the equivalent ckt of the crystal? What is the quality factor of the crystal? 15

- (b) For a  $p-n-p$  transistor show that the injection efficiency of the emitter is given by

$$\gamma = \frac{1}{1 + \frac{N_d W_B \mu_e}{N_a W_e \mu_h}}$$

where  $N_d$ ,  $N_a$ ,  $W_B$  and  $W_e$ ,  $\mu_e$ ,  $\mu_h$  have their standard meanings. 10

- (c) Explain the features of soft-magnetic materials with suitable examples and uses. 5

- (d) Consider a torodial coil with a ferrite core. Suppose the coil has 200 turns and is used in high frequency with small signals. The mean diameter of the toroid is 2.5 cm and the core diameter is 0.5 cm. If the core is MnZn ferrite what is the approximate inductance of the coil ?

Given Relative permeability  $\mu_r = 2 \times 10^3$ . 10

7. (a) A sheet of bakelite 4.5 mm thick is tested at 50 Hz between electrodes 0.12 m in diameter. The Schering bridge employs a standard air capacitor  $C_2$  of 106 pF, a non-reactive resistance  $R_4$  of  $1000/\pi$  ohms in parallel with a variable capacitor  $C_4$  and a non-reactive variable resistance  $R_3$ . Balance is obtained with  $C_4 = 0.5$  pF and  $R_2 = 260 \Omega$ . Calculate the capacitance, power factor and relative permittivity of the sheet. 15

- (b) A dual slope ADC uses a 16 bit counter and a 4 MHz clock rate. The maximum input voltage is +10 V. The maximum integrator output should be  $-8$  V, when the counter has cycled through  $2^n$  counts. The capacitor used in the integrator is  $0.1 \mu\text{F}$ . Find the value of the resistor  $R$  of the integrator. 10

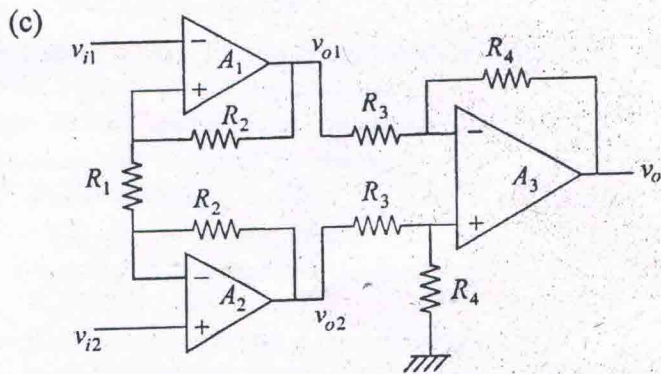

The instrumentation amplifier using Op-Amp is shown above. Calculate the value of  $R_1$ ,  $R_2$ ,  $R_3$  and  $R_4$  so as to obtain the gain of the amplifier as 2. 15