

**SB/
SX**

KVPY QUESTION PAPER – STREAM SB/SX

November 2, 2014

PART I
One-Mark Questions

MATHEMATICS

1 Let C_0 be a circle of radius 1. For $n \geq 1$, let C_n be a circle whose area equals the area of a square inscribed in C_{n-1} . Then $\sum_{i=0}^{\infty} \text{Area}(C_i)$ equals

- A. π^2 B. $\frac{\pi-2}{\pi^2}$
C. $\frac{1}{\pi^2}$ D. $\frac{\pi^2}{\pi-2}$

2 For a real number r we denote by $[r]$ the largest integer less than or equal to r . If x, y are real numbers with $x, y \geq 1$ then which of the following statements is always true?

- A. $[x+y] \leq [x] + [y]$ B. $[xy] \leq [x][y]$
C. $[2^x] \leq 2^{[x]}$ D. $\left[\frac{x}{y} \right] \leq \frac{[x]}{[y]}$

3 For each positive integer n , let $A_n = \max \left\{ \binom{n}{r} \mid 0 \leq r \leq n \right\}$. Then the number of

elements n in $\{1, 2, \dots, 20\}$ for which $1.9 \leq \frac{A_n}{A_{n-1}} \leq 2$ is

- A. 9 B. 10
C. 11 D. 12

- 4 Let $b, d > 0$. The locus of all points $P(r, \theta)$ for which the line OP (where O is the origin) cuts the line $r \sin \theta = b$ in Q such that $PQ = d$ is
- $(r-d) \sin \theta = b$
 - $(r \pm d) \sin \theta = b$
 - $(r-d) \cos \theta = b$
 - $(r \pm d) \cos \theta = b$

- 5 Let C be the circle $x^2 + y^2 = 1$ in the xy -plane. For each $t \geq 0$, let L_t be the line passing through $(0, 1)$ and $(t, 0)$. Note that L_t intersects C in two points, one of which is $(0, 1)$. Let Q_t be the other point. As t varies between 1 and $1 + \sqrt{2}$, the collection of points Q_t sweeps out an arc on C . The angle subtended by this arc at $(0, 0)$ is

- $\frac{\pi}{8}$
- $\frac{\pi}{4}$
- $\frac{\pi}{3}$
- $\frac{3\pi}{8}$

- 6 In an ellipse, its foci and the ends of its major axis are equally spaced. If the length of its semi-minor axis is $2\sqrt{2}$, then the length of its semi-major axis is

- 4
- $2\sqrt{3}$
- $\sqrt{10}$
- 3

4

- 7 Let ABC be a triangle such that $AB = BC$. Let F be the midpoint of AB and X be a point on BC such that FX is perpendicular to AB . If $BX = 3XC$ then the ratio BC/AC equals
- $\sqrt{3}$
 - $\sqrt{2}$
 - $\sqrt{\frac{3}{2}}$
 - 1

- 8 The number of solutions to the equation $\cos^4 x + \frac{1}{\cos^2 x} = \sin^4 x + \frac{1}{\sin^2 x}$ in the interval $[0, 2\pi]$ is
- 6
 - 4
 - 2
 - 0

- 9 Consider the function

$$f(x) = \begin{cases} \frac{x+5}{x-2} & \text{if } x \neq 2 \\ 1 & \text{if } x = 2. \end{cases}$$

Then $f(f(x))$ is discontinuous

- at all real numbers
- at exactly two values of x
- at exactly one value of x
- at exactly three values of x

5

10 For a real number x let $[x]$ denote the largest number less than or equal to x . For $x \in \mathbb{R}$ let $f(x) = [x] \sin \pi x$. Then

- A. f is differentiable on \mathbb{R} .
- B. f is symmetric about the line $x = 0$.
- C. $\int_{-3}^3 f(x) dx = 0$.
- D. For each real α , the equation $f(x) - \alpha = 0$ has infinitely many roots.

11 Let $f : [0, \pi] \rightarrow \mathbb{R}$ be defined as

$$f(x) = \begin{cases} \sin x, & \text{if } x \text{ is irrational and } x \in [0, \pi] \\ \tan^2 x, & \text{if } x \text{ is rational and } x \in [0, \pi] \end{cases}$$

The number of points in $[0, \pi]$ at which the function f is continuous is

- A. 6
- B. 4
- C. 2
- D. 0

12 Let $f : [0, 1] \rightarrow [0, \infty)$ be a continuous function such that

$\int_0^1 f(x) dx = 10$. Which of the following statements is NOT necessarily true?

- A. $\int_0^1 e^{-x} f(x) dx \leq 10$
- B. $\int_0^1 \frac{f(x)}{(1+x)^2} dx \leq 10$
- C. $-10 \leq \int_0^1 \sin(100x) f(x) dx \leq 10$
- D. $\int_0^1 f(x)^2 dx \leq 100$

13 A continuous function $f : \mathbb{R} \rightarrow \mathbb{R}$ satisfies the equation

$$f(x) = x + \int_0^x f(t) dt.$$

Which of the following options is true?

- A. $f(x+y) = f(x) + f(y)$
- B. $f(x+y) = f(x)f(y)$
- C. $f(x+y) = f(x) + f(y) + f(x)f(y)$
- D. $f(x+y) = f(xy)$

14 For a real number x let $[x]$ denote the largest integer less than or equal to x and $\{x\} = x - [x]$. Let n be a positive integer. Then $\int_0^n \cos(2\pi[x]\{x\}) dx$ is equal to

- A. 0
- B. 1
- C. n
- D. $2n-1$

15 Two persons A and B throw a (fair) die (six-faced cube with faces numbered from 1 to 6) alternately, starting with A . The first person to get an outcome different from the previous one by the opponent wins. The probability that B wins is

- A. $\frac{5}{6}$
- B. $\frac{6}{7}$
- C. $\frac{7}{8}$
- D. $\frac{8}{9}$

- 16 Let $n \geq 3$. A list of numbers x_1, x_2, \dots, x_n has mean μ and standard deviation σ . A new list of numbers y_1, y_2, \dots, y_n is made as follows: $y_1 = \frac{x_1 + x_2}{2}$, $y_2 = \frac{x_1 + x_2}{2}$ and $y_j = x_j$ for $j = 3, 4, \dots, n$. The mean and the standard deviation of the new list are $\hat{\mu}$ and $\hat{\sigma}$. Then which of the following is necessarily true?
- A. $\mu = \hat{\mu}$ and $\sigma \leq \hat{\sigma}$
 B. $\mu = \hat{\mu}$ and $\sigma \geq \hat{\sigma}$
 C. $\sigma = \hat{\sigma}$
 D. $\hat{\mu} \neq \hat{\sigma}$
- 17 What is the angle subtended by an edge of a regular tetrahedron at its center?
- A. $\cos^{-1}\left(\frac{-1}{2}\right)$
 B. $\cos^{-1}\left(\frac{-1}{\sqrt{2}}\right)$
 C. $\cos^{-1}\left(\frac{-1}{3}\right)$
 D. $\cos^{-1}\left(\frac{-1}{\sqrt{3}}\right)$
- 18 Let $S = \{(a, b) : a, b \in \mathbb{Z}, 0 \leq a, b \leq 18\}$. The number of elements (x, y) in S such that $3x + 4y + 5$ is divisible by 19 is
- A. 38
 B. 19
 C. 18
 D. 1

- 19 For a real number r let $[r]$ denote the largest integer less than or equal to r . Let $a > 1$ be a real number which is not an integer, and let k be the smallest positive integer such that $[a^k] > [a]^k$. Then which of the following statements is always true?
- A. $k \leq 2([a] + 1)^2$
 B. $k \leq ([a] + 1)^4$
 C. $k \leq 2^{[a]+1}$
 D. $k \leq \frac{1}{a - [a]} + 1$
- 20 Let X be a set of 5 elements. The number d of ordered pairs (A, B) of subsets of X such that $A \neq \phi, B \neq \phi, A \cap B = \phi$ satisfies
- A. $50 \leq d \leq 100$
 B. $101 \leq d \leq 150$
 C. $151 \leq d \leq 200$
 D. $201 \leq d$

PHYSICS

21 A uniform thin rod of length $2L$ and mass m lies on a horizontal table. A horizontal impulse J is given to the rod at one end. There is no friction. The total kinetic energy of the rod just after the impulse will be

- A. $\frac{J^2}{2m}$ B. $\frac{J^2}{m}$
 C. $\frac{2J^2}{m}$ D. $\frac{6J^2}{m}$

22 A solid cylinder P rolls without slipping from rest down an inclined plane attaining a speed v_p at the bottom. Another smooth solid cylinder Q of same mass and dimensions slides without friction from rest down the inclined plane attaining a speed v_q at the bottom. The ratio of the speeds

$\left(\frac{v_q}{v_p}\right)$ is

- A. $\sqrt{3/4}$ B. $\sqrt{3/2}$
 C. $\sqrt{2/3}$ D. $\sqrt{4/3}$

23 A body moves in a circular orbit of radius R under the action of a central force. Potential due to the central force is given by $V(r) = kr$ (k is a positive constant). Period of revolution of the body is proportional to

- A. $R^{1/2}$ B. $R^{-1/2}$
 C. $R^{-3/2}$ D. $R^{-5/2}$

24 A simple pendulum is attached to a block which slides without friction down an inclined plane (ABC) having an angle of inclination α as shown.

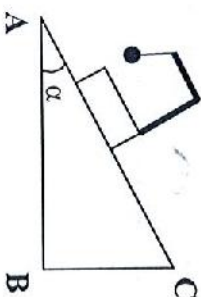

While the block is sliding down the pendulum oscillates in such a way that at its mean position the direction of the string is

- A. at angle α to the perpendicular to the inclined plane AC.
 B. parallel to the inclined plane AC.
 C. vertically downwards.
 D. perpendicular to the inclined plane AC.

25 Water containing air bubbles flows without turbulence through a horizontal pipe which has a region of narrow cross-section. In this region the bubbles

- A. move with greater speed and are smaller than in the rest of the pipe.
 B. move with greater speed and are larger in size than in the rest of the pipe.
 C. move with lesser speed and are smaller than in the rest of the pipe.
 D. move with lesser speed and are of the same size as in the rest of the pipe.

- 26 A solid expands upon heating because
- the potential energy of interaction between atoms in the solid is asymmetric about the equilibrium positions of atoms.
 - the frequency of vibration of the atoms increases.
 - the heating generates a thermal gradient between opposite sides.
 - a fluid called the caloric flows into the interatomic spacing of the solid during heating thereby expanding it.
- 27 Consider two thermometers T_1 and T_2 of equal length which can be used to measure temperature over the range θ_1 to θ_2 . T_1 contains mercury as the thermometric liquid while T_2 contains bromine. The volumes of the two liquids are the same at the temperature θ_1 . The volumetric coefficients of expansion of mercury and bromine are $18 \times 10^{-5} \text{ K}^{-1}$ and $108 \times 10^{-5} \text{ K}^{-1}$, respectively. The increase in length of each liquid is the same for the same increase in temperature. If the diameters of the capillary tubes of the two thermometers are d_1 and d_2 respectively, then the ratio $d_1:d_2$ would be closest to
- 6.0
 - 2.5
 - 0.6
 - 0.4
- 28 An ideal gas follows a process described by $PR^2 = C$ from (P_1, V_1, T_1) to (P_2, V_2, T_2) (C is a constant). Then
- if $P_1 > P_2$ then $T_2 > T_1$
 - if $V_2 > V_1$ then $T_2 < T_1$
 - if $V_2 > V_1$ then $T_2 > T_1$
 - if $P_1 > P_2$ then $V_1 > V_2$

- 29 A whistle emitting a loud sound of frequency 540 Hz is whirled in a horizontal circle of radius 2 m and at a constant angular speed of 15 rad/s. The speed of sound is 330 m/s. The ratio of the highest to the lowest frequency heard by a listener standing at rest at a large distance from the center of the circle is
- 1.0
 - 1.1
 - 1.2
 - 1.4

- 30 Monochromatic light passes through a prism. Compared to that in air, inside the prism the light's
- speed and wavelength are different but frequency remains same.
 - speed and frequency are different but wavelength remains same.
 - wavelength and frequency are different, but speed remains same.
 - speed, wavelength and frequency are all different.
- 31 The flat face of a plano-convex lens of focal length 10 cm is silvered. A point source placed 30 cm in front of the curved surface will produce a
- real image 15 cm away from the lens.
 - real image 6 cm away from the lens.
 - virtual image 15 cm away from the lens.
 - virtual image 6 cm away from the lens.

- 32 Two identical metallic square loops L_1 and L_2 are placed next to each other with their sides parallel on a smooth horizontal table. Loop L_1 is fixed and a current which increases as a function of time is passed through it. Then loop L_2
- rotates about its center of mass.
 - moves towards L_1 .
 - remains stationary.
 - moves away from L_1 .

- 33 An electron enters a parallel plate capacitor with horizontal speed u and is found to deflect by angle θ on leaving the capacitor as shown. It is found that $\tan\theta = 0.4$ and gravity is negligible

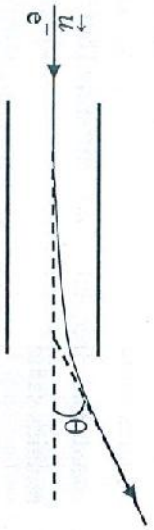

- If the initial horizontal speed is doubled, then $\tan\theta$ will be
- 0.1
 - 0.2
 - 0.8
 - 1.6

- 34 Consider a spherical shell of radius R with a total charge $+Q$ uniformly spread on its surface (center of the shell lies at the origin $x = 0$). Two point charges, $+q$ and $-q$ are brought, one after the other, from far away and placed at $x = -a/2$ and $x = +a/2$ ($a < R$), respectively. Magnitude of the work done in this process is
- $(Q+q)^2/4\pi\epsilon_0 a$
 - zero
 - $q^2/4\pi\epsilon_0 a$
 - $Qq/4\pi\epsilon_0 a$

- 35 Two identical parallel plate capacitors of capacitance C each are connected in series with a battery of emf, E as shown. If one of the capacitors is now filled with a dielectric of dielectric constant k , the amount of charge which will flow through the battery is (neglect internal resistance of the battery)

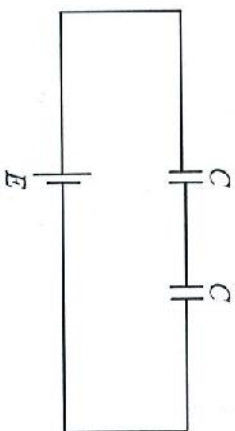

- $\frac{k+1}{2(k-1)}CE$
- $\frac{k-1}{2(k+1)}CE$
- $\frac{k-2}{k+2}CE$
- $\frac{k+2}{k-2}CE$

- 36 A certain p-n junction, having a depletion region of width $20\ \mu\text{m}$, was found to have a breakdown voltage of $100\ \text{V}$. If the width of the depletion region is reduced to $1\ \mu\text{m}$ during its production, then it can be used as a Zener diode for voltage regulation of

- 5 V
- 10 V
- 7.5 V
- 2000 V

- 37 The half life of a particle of mass $1.6 \times 10^{-26}\ \text{kg}$ is $6.9\ \text{s}$ and a stream of such particles is travelling with the kinetic energy of a particle being $0.05\ \text{eV}$. The fraction of particles which will decay when they travel a distance of $1\ \text{m}$ is
- 0.1
 - 0.01
 - 0.001
 - 0.0001

CHEMISTRY

- 38 A 160 watt light source is radiating light of wavelength 6200 Å uniformly in all directions. The photon flux at a distance of 1.8 m is of the order of (Planck's constant 6.63×10^{-34} J-s)
- A. $10^2 \text{ m}^{-2} \text{ s}^{-1}$
 B. $10^{12} \text{ m}^{-2} \text{ s}^{-1}$
 C. $10^{19} \text{ m}^{-2} \text{ s}^{-1}$
 D. $10^{25} \text{ m}^{-2} \text{ s}^{-1}$
- 39 The wavelength of the first Balmer line caused by a transition from the $n = 3$ level to the $n = 2$ level in hydrogen is λ_1 . The wavelength of the line caused by an electronic transition from $n = 5$ to $n = 3$ is
- A. $\frac{375}{128} \lambda_1$
 B. $\frac{125}{64} \lambda_1$
 C. $\frac{64}{125} \lambda_1$
 D. $\frac{128}{375} \lambda_1$
- 40 The binding energy per nucleon of ${}^8\text{B}^{10}$ is 8.0 MeV and that of ${}^8\text{B}^{11}$ is 7.5 MeV. The energy required to remove a neutron from ${}^8\text{B}^{11}$ is (mass of electron and proton are 9.11×10^{-31} kg and 1.67×10^{-27} kg, respectively)
- A. 2.5 MeV. B. 8.0 MeV.
 C. 0.5 MeV. D. 7.5 MeV.

- 41 When 1.88 g of AgBr(s) is added to a 10^{-3} M aqueous solution of KBr, the concentration of Ag^+ is 5×10^{-10} M. If the same amount of AgBr(s) is added to a 10^{-2} M aqueous solution of AgNO_3 , the concentration of Br^- is
- A. 9.4×10^{-9} M B. 5×10^{-10} M
 C. 1×10^{-11} M D. 5×10^{-11} M

- 42 Aniline reacts with excess $\text{Br}_2/\text{H}_2\text{O}$ to give the major product

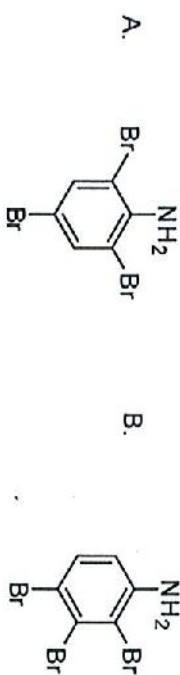

- 43 The metal with the highest oxidation state present in K_2CrO_4 , NbCl_5 and MnO_2 is
- A. Nb B. Mn
 C. K D. Cr

44 The number of geometrical isomers of $[\text{CrCl}_2(\text{en})(\text{NH}_3)_2]_2$, where en = ethylenediamine, is

- A. 2
B. 3
C. 4
D. 1

45 The element that combines with oxygen to give an amphoteric oxide is

- A. N
B. P
C. Al
D. Na

46 The Arrhenius plots of two reactions, I and II are shown graphically

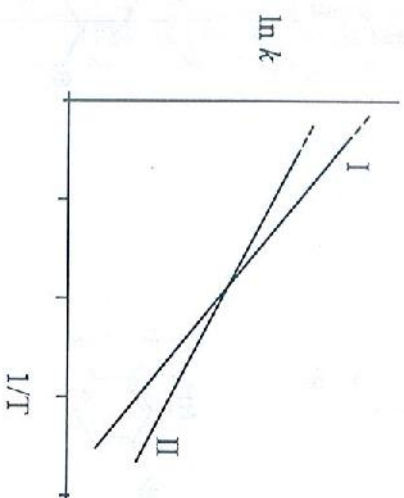

The graph suggests that

- A. $E_I > E_{II}$ and $A_I > A_{II}$
B. $E_{II} > E_I$ and $A_{II} > A_I$
C. $E_I > E_{II}$ and $A_{II} > A_I$
D. $E_{II} > E_I$ and $A_I > A_{II}$

47 $\text{Ni}(\text{CO})_4$ is

- A. tetrahedral and paramagnetic
B. square planar and diamagnetic
C. tetrahedral and diamagnetic
D. square planar and paramagnetic

48 In the following reaction,

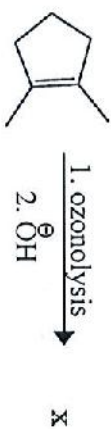

the major product X is

- A.
- B.
- C.
- D.

49 Given the structure of D-(+)-glucose as

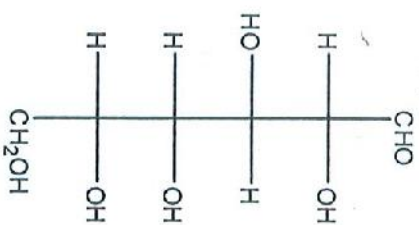

The structure of L-(-)-glucose is

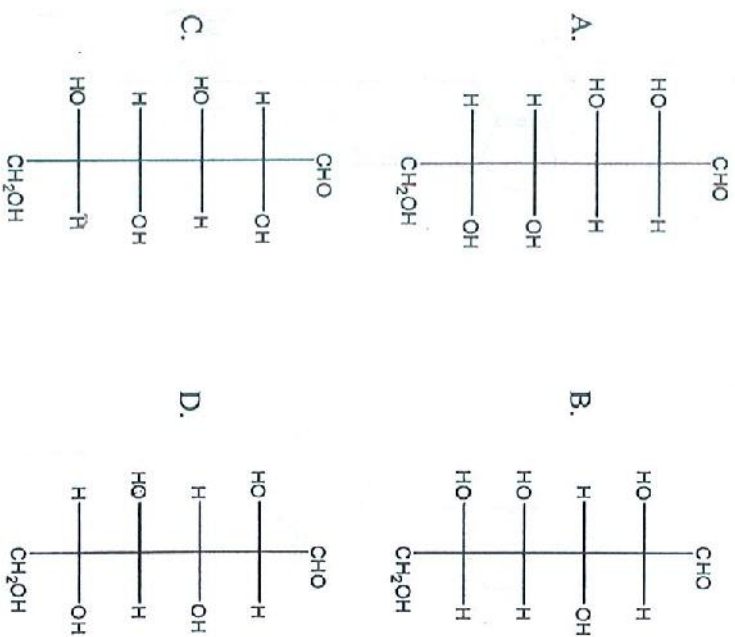

20

50 In a cubic close packed structure, fractional contributions of an atom at the corner and at the face in the unit cell are, respectively

- A. 1/8 and 1/2 B. 1/2 and 1/4
 C. 1/4 and 1/2 D. 1/4 and 1/8

51 The equilibrium constant K_c of the reaction, $2A \rightleftharpoons B + C$ is 0.5 at 25 °C and 1 atm. The reaction will proceed in the backward direction when concentrations $[A]$, $[B]$ and $[C]$ are, respectively

- A. 10^{-3} , 10^{-2} and 10^{-2} M
 B. 10^{-1} , 10^{-2} and 10^{-2} M
 C. 10^{-2} , 10^{-2} and 10^{-3} M
 D. 10^{-2} , 10^{-3} and 10^{-3} M

52 Major products formed in the reaction of t-butyl methyl ether with HI are

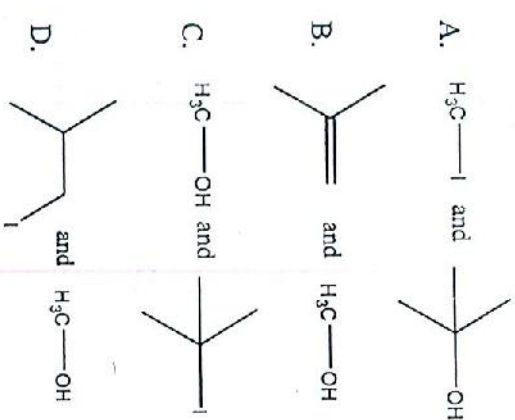

21

53 If the molar conductivities (in $S\text{ cm}^2\text{ mol}^{-1}$) of NaCl, KCl and NaOH at infinite dilution are 126, 150 and 250, respectively, the molar conductivity of KOH (in $S\text{ cm}^2\text{ mol}^{-1}$) is

- A. 526
B. 226
C. 26
D. 274

54 4-Formylbenzoic acid on treatment with one equivalent of hydrazine followed by heating with alcoholic KOH gives the major product

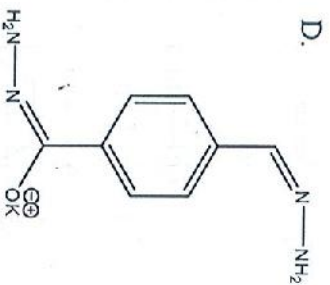
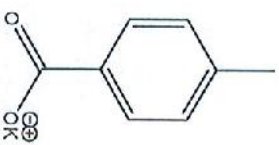
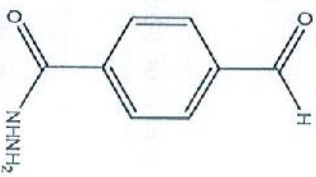

55 Two elements, X and Y, have atomic numbers 33 and 17, respectively. The molecular formula of a stable compound formed between them is

- A. XY
B. XY_2
C. XY_3
D. XY_4

56 The number of moles of $KMnO_4$ required to oxidize one equivalent of KI in the presence of sulfuric acid is

- A. 5
B. 2
C. $1/2$
D. $1/5$

57 Three successive measurements in an experiment gave the values 10.9, 11.4042 and 11.42. The correct way of reporting the average value is

- A. 11.2080
B. 11.21
C. 11.2
D. 11

58 The latent heat of melting of ice at 0°C is 6 kJ mol^{-1} . The entropy change during the melting in $\text{J K}^{-1}\text{ mol}^{-1}$ is closest to

- A. 22
B. 11
C. -11
D. -22

59 The major product of the following reaction



is

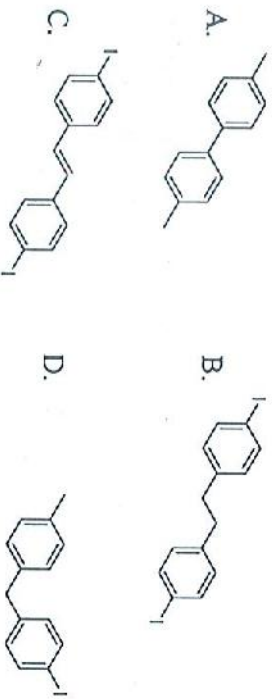

60 The energies of d_{xy} and d_z^2 orbitals in octahedral and tetrahedral transition metal complexes are such that

- A. $E(d_{xy}) > E(d_z^2)$ in both tetrahedral and octahedral complexes
- B. $E(d_{xy}) < E(d_z^2)$ in both tetrahedral and octahedral complexes
- C. $E(d_{xy}) > E(d_z^2)$ in tetrahedral but $E(d_{xy}) < E(d_z^2)$ in octahedral complexes
- D. $E(d_{xy}) < E(d_z^2)$ in tetrahedral but $E(d_{xy}) > E(d_z^2)$ in octahedral complexes

24

BIOLOGY

61 In which of the following types of glands is the secretion collected inside the cell and discharged by disintegration of the entire gland?

- A. Apocrine
- B. Merocrine
- C. Holocrine
- D. Epicrine

62 Which one of the following interactions does **NOT** promote coevolution?

- A. Commensalism
- B. Mutualism
- C. Parasitism
- D. Interspecific competition

63 Stratification is more common in which of the following?

- A. Deciduous forest
- B. Tropical rain forest
- C. Temperate forest
- D. Tropical savannah

64 Where is the third ventricle of the brain located?

- A. Cerebrum
- B. Cerebellum
- C. Pons varoli
- D. Diencephalon

65 Which of the following is the final product of a gene?

- A. a polypeptide only
- B. an RNA only
- C. either polypeptide or RNA
- D. a nucleotide only

25

- 66 Forelimbs of whales, bats, humans and cheetah are examples of which of the following processes?
- Divergent evolution
 - Convergent evolution
 - Adaptation
 - Saltation
- 67 Which of the following results from conjugation in *Paramecium*?
- Cell death
 - Cell division
 - Budding
 - Recombination
- 68 In an experiment investigating photoperiodic response, the leaves of a plant are removed. What is the most likely outcome?
- Photoperiodism is not affected
 - Photoperiodic response does not occur
 - The plant starts flowering
 - The plant starts to grow taller
- 69 Testosterone is secreted by which endocrine part of testis?
- Leydig cells
 - Seminiferous tubules
 - Tunica albuginea
 - Sertoli cells
- 70 The mutation of a purine to a pyrimidine is known as
- transition
 - frame shift
 - nonsense
 - transversion
- 71 Which of the following is secreted at the ends of an axon?
- Ascorbic acid
 - Acetic acid
 - Acetyl choline
 - Acetyl CoA
- 72 A bacterial colony is produced from
- a single bacterium by its repetitive division
 - multiple bacterium without replication
 - clumping of two to three bacteria
 - a single bacterium without cell division
- 73 Rhinoviruses are the causative agents of
- Diarrhoea
 - AIDS
 - Dengue
 - Common cold

- 74 What is the genetic material of Ebola virus?
- Single-stranded DNA
 - Double-stranded RNA
 - Single-stranded RNA
 - Double-stranded DNA
- 75 Name the terminal acceptor of electrons in the mitochondrial electron transport chain
- Nitrate
 - Fumarate
 - Succinate
 - Oxygen
- 76 Two tubes labeled 'P' and 'Q' contain food stuff. Tube 'P' gave positive test with Benedict's solution while tube 'Q' gave positive test with Nitric acid. Which of the following is correct?
- Tube 'P' contains sugar; tube 'Q' contains protein
 - Tube 'P' contains protein; tube 'Q' contains sugar
 - Both, tube 'P' and tube 'Q' contain sugar
 - Both, tube 'P' and tube 'Q' contain protein
- 77 How many linear DNA fragments will be produced when a circular plasmid is digested with a restriction enzyme having 3 sites?
- 4
 - 5
 - 3
 - 2
- 78 If the humidity of the atmosphere suddenly increases substantially, the water flow in the xylem will
- increase
 - decrease
 - remain unaltered
 - increase sharply and then reduce slowly to the pre-existing level
- 79 Which one of the following is the complementary sequence for the DNA with 5'-CGTACTA-3'
- 5'-TAGTACG-3'
 - 5'-ATCATGC-3'
 - 5'-UTCUTGC-3'
 - 5'-GCUAGCA-3'
- 80 A diploid plant has 14 chromosomes, but its egg cell has 6 chromosomes. Which one of the following is the most likely explanation of this?
- Non-disjunction in meiosis I and II
 - Non-disjunction in meiosis I
 - Non-disjunction in mitosis
 - Normal meiosis

PART II
Two-Mark Questions

MATHEMATICS

81 Let $n \geq 3$ be an integer. For a permutation $\sigma = (a_1, a_2, \dots, a_n)$ of $(1, 2, \dots, n)$ we let $f_\sigma(x) = a_n x^{n-1} + a_{n-1} x^{n-2} + \dots + a_2 x + a_1$. Let S_σ be the sum of the roots of $f_\sigma(x) = 0$ and let S denote the sum over all permutations σ of $(1, 2, \dots, n)$ of the numbers S_σ . Then

- A. $S < -n!$ B. $-n! < S < 0$
C. $0 < S < n!$ D. $n! < S$

82 If n is a positive integer and $\omega \neq 1$ is a cube root of unity, the number of possible values of

$$\left| \sum_{k=0}^n \binom{n}{k} \omega^k \right|$$

- is
A. 2 B. 3
C. 4 D. 6

83 Suppose a parabola $y = ax^2 + bx + c$ has two x intercepts, one positive and one negative, and its vertex is $(2, -2)$. Then which of the following is true?

- A. $ab > 0$ B. $bc > 0$
C. $ca > 0$ D. $a + b + c > 0$

84 Let $n \geq 3$ and let C_1, C_2, \dots, C_n be circles with radii r_1, r_2, \dots, r_n , respectively. Assume that C_i and C_{i+1} touch externally for $1 \leq i \leq n-1$. It is also given that the x -axis and the line $y = 2\sqrt{2}x + 10$ are tangential to each of the circles. Then r_1, r_2, \dots, r_n are in

A. an arithmetic progression with common difference $3 + \sqrt{2}$
B. a geometric progression with common ratio $3 + \sqrt{2}$
C. an arithmetic progression with common difference $2 + \sqrt{3}$
D. a geometric progression with common ratio $2 + \sqrt{3}$

85 The number of integers n for which $3x^3 - 25x + n = 0$ has three real roots is

- A. 1 B. 25
C. 55 D. infinite

86 An ellipse inscribed in a semi-circle touches the circular arc at two distinct points and also touches the bounding diameter. Its major axis is parallel to the bounding diameter. When the ellipse has the maximum possible area, its eccentricity is

- A. $\frac{1}{\sqrt{2}}$ B. $\frac{1}{2}$
C. $\frac{1}{\sqrt{3}}$ D. $\frac{\sqrt{2}}{\sqrt{3}}$

87 Let $I_n = \int_0^{\pi/2} x^n \cos x \, dx$, where n is a non-negative integer.

Then $\sum_{n=2}^{\infty} \left(\frac{I_n}{n!} + \frac{I_{n-2}}{(n-2)!} \right)$ equals

- A. $e^{\pi/2} - 1 - \frac{\pi}{2}$ B. $e^{\pi/2} - 1$
 C. $e^{\pi/2} - \frac{\pi}{2}$ D. $e^{\pi/2}$

88 For a real number x let $[x]$ denote the largest integer less than or equal to x . The smallest positive integer n for which the integral $\int_1^n [x] \sqrt{x} \, dx$ exceeds 60 is

- A. 8 B. 9
 C. 10 D. $[60^{2/3}]$

89 Choose a number n uniformly at random from the set $\{1, 2, \dots, 100\}$. Choose one of the first seven days of the year 2014 at random and consider n consecutive days starting from the chosen day. What is the probability that among the chosen n days, the number of Sundays is different from the number of Mondays?

- A. $\frac{1}{2}$ B. $\frac{2}{7}$
 C. $\frac{12}{49}$ D. $\frac{43}{175}$

90 Let $S = \{(a, b) \mid a, b \in \mathbb{Z}, 0 \leq a, b \leq 18\}$. The number of lines in \mathbb{R}^2 passing through $(0, 0)$ and exactly one other point in S is

- A. 16 B. 22
 C. 28 D. 32

PHYSICS

91 A solid sphere spinning about a horizontal axis with an angular velocity ω is placed on a horizontal surface. Subsequently it rolls without slipping with an angular velocity of

- A. $2\omega/5$
 B. $7\omega/5$
 C. $2\omega/7$
 D. ω

92 Consider the system shown below.

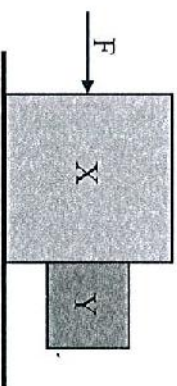

A horizontal force F is applied to a block X of mass 8 kg such that the block Y of mass 2 kg adjacent to it does not slip downwards under gravity. There is no friction between the horizontal plane and the base of the block X . The coefficient of friction between the surfaces of blocks X and Y is 0.5. Take acceleration due to gravity to be 10 ms^{-2} . The minimum value of F is

- A. 200 N
 B. 160 N
 C. 40 N
 D. 240 N

- 93 The maximum value attained by the tension in the string of a swinging pendulum is four times the minimum value it attains. There is no slack in the string. The angular amplitude of the pendulum is
- A. 90°
 B. 60°
 C. 45°
 D. 30°

- 94 One mole of a monoatomic ideal gas is expanded by a process described by $PV^3 = C$ where C is a constant. The heat capacity of the gas during the process is given by (R is the gas constant).

- A. $2R$
 B. $\frac{5}{2}R$
 C. $\frac{3}{2}R$
 D. R

- 95 A concave mirror of radius of curvature R has a circular outline of radius r . A circular disk is to be placed normal to the axis at the focus so that it collects all the light that is reflected from the mirror from a beam parallel to the axis. For $r \ll R$, the area of this disc has to be at least

- A. $\frac{\pi r^6}{4R^4}$
 B. $\frac{\pi r^4}{4R^2}$
 C. $\frac{\pi r^5}{4R^3}$
 D. $\frac{\pi r^4}{R^2}$

- 96 The angles of incidence and refraction of a monochromatic ray of light of wavelength λ at an air-glass interface are i and r , respectively. A parallel beam of light with a small spread $\delta\lambda$ in wavelength about a mean wavelength λ is refracted at the same air-glass interface. The refractive index μ of glass depends on the wavelength λ as $\mu(\lambda) = a + b/\lambda^2$ where a and b are constants. Then the angular spread in the angle of refraction of the beam is

- A. $\left| \frac{\sin i}{\lambda^3 \cos r} \delta\lambda \right|$
 B. $\left| \frac{2b}{\lambda^3} \delta\lambda \right|$
 C. $\left| \frac{2b \tan r}{a\lambda^3 + b\lambda} \delta\lambda \right|$
 D. $\left| \frac{2b(a + b/\lambda^2) \sin i}{\lambda^3} \delta\lambda \right|$

- 97 What are the charges stored in the $1 \mu\text{F}$ and $2 \mu\text{F}$ capacitors in the circuit below, once the currents become steady?

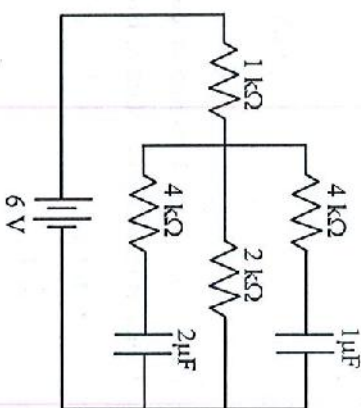

- A. $8 \mu\text{C}$ and $4 \mu\text{C}$ respectively
 B. $4 \mu\text{C}$ and $8 \mu\text{C}$ respectively
 C. $3 \mu\text{C}$ and $6 \mu\text{C}$ respectively
 D. $6 \mu\text{C}$ and $3 \mu\text{C}$ respectively

98 A 1.5 kW (kilo-watt) laser beam of wavelength 6400 Å is used to levitate a thin aluminium disk of same area as the cross section of the beam. The laser light is reflected by the aluminium disk without any absorption. The mass of the foil is close to

- A. 10^{-9} kg
- B. 10^{-3} kg
- C. 10^{-4} kg
- D. 10^{-6} kg

99 When ultraviolet radiation of a certain frequency falls on a potassium target, the photoelectrons released can be stopped completely by a retarding potential of 0.6 V. If the frequency of the radiation is increased by 10%, this stopping potential rises to 0.9 V. The work function of potassium is

- A. 2.0 eV
- B. 2.4 eV
- C. 3.0 eV
- D. 2.8 eV

100 The dimensions of Stefan-Boltzmann constant σ can be written in terms of Planck's constant h , Boltzmann constant k_B and the speed of light c as $\sigma = h^\alpha k_B^\beta c^\gamma$. Here

- A. $\alpha = 3, \beta = 4$ and $\gamma = -3$
- B. $\alpha = 3, \beta = -4$ and $\gamma = 2$
- C. $\alpha = -3, \beta = 4$ and $\gamma = -2$
- D. $\alpha = 2, \beta = -3$ and $\gamma = -1$

CHEMISTRY

101 In the reaction sequence

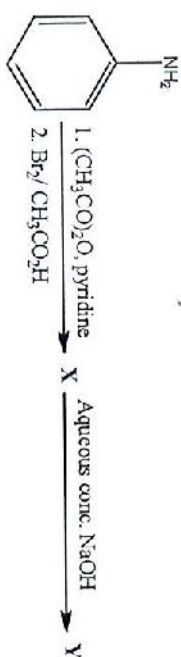

X and Y are, respectively,

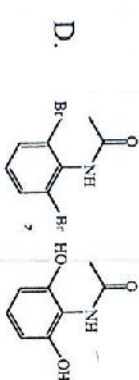
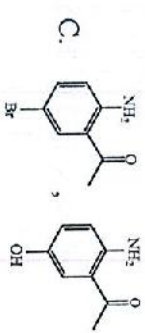
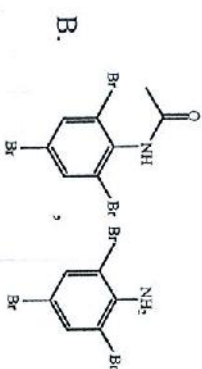
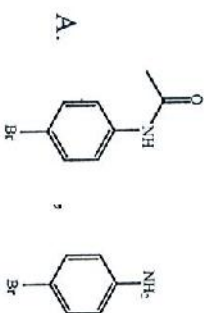

- 102 The density of acetic acid vapor at 300 K and 1 atm is 5 mg cm^{-3} . The number of acetic acid molecules in the cluster that is formed in the gas phase is closest to
- A. 5
B. 2
C. 3
D. 4

- 103 The molar enthalpy change for $\text{H}_2\text{O}(\text{l}) \rightleftharpoons \text{H}_2\text{O}(\text{g})$ at 373 K and 1 atm is 41 kJ/mol. Assuming ideal behavior, the internal energy change for vaporization of 1 mol of water at 373 K and 1 atm in kJ mol^{-1} is
- A. 30.2
B. 41.0
C. 48.1
D. 37.9

- 104 The equilibrium constants (K_c) of two reactions $\text{H}_2 + \text{I}_2 \rightleftharpoons 2\text{HI}$ and $\text{N}_2 + 3\text{H}_2 \rightleftharpoons 2\text{NH}_3$ are 50 and 1000, respectively. The equilibrium constant of the reaction $\text{N}_2 + 6\text{HI} \rightleftharpoons 2\text{NH}_3 + 3\text{I}_2$ is closest to
- A. 50000
B. 20
C. 0.008
D. 0.005

- 105 Given that the bond energies of: $\text{N}\equiv\text{N}$ is 946 kJ mol^{-1} , $\text{H}-\text{H}$ is 435 kJ mol^{-1} , $\text{N}-\text{N}$ is 159 kJ mol^{-1} , and $\text{N}-\text{H}$ is 389 kJ mol^{-1} , the heat of formation of hydrazine in the gas phase in kJ mol^{-1} is
- A. 833
B. 101
C. 334
D. 1268

- 106 The radius of K^+ is 133 pm and that of Cl^- is 181 pm. The volume of the unit cell of KCl expressed in 10^{-22} cm^3 is
- A. 0.31
B. 1.21
C. 2.48
D. 6.28

- 107 The reaction, $\text{K}_2\text{Cr}_2\text{O}_7 + m \text{FeSO}_4 + n \text{H}_2\text{SO}_4 \rightarrow \text{Cr}_2(\text{SO}_4)_3 + p \text{Fe}_2(\text{SO}_4)_3 + q \text{K}_2\text{SO}_4 + r \text{H}_2\text{O}$ when balanced, m, n, p, and q are, respectively
- A. 6, 14, 3, 14
B. 6, 7, 3, 7
C. 3, 7, 2, 7
D. 4, 14, 2, 14

- 108 The standard free energy change (in J) for the reaction $3\text{Fe}^{2+}(\text{aq}) + 2\text{Cr}(\text{s}) = 2\text{Cr}^{3+}(\text{aq}) + 3\text{Fe}(\text{s})$ given $E_{\text{Fe}^{3+}/\text{Fe}}^\circ = -0.44 \text{ V}$ and $E_{\text{Cr}^{3+}/\text{Cr}}^\circ = -0.74 \text{ V}$ is ($F = 96500 \text{ C}$)
- A. 57,900
B. -57,900
C. -173,700
D. 173,700

109 Calcium butanoate on heating followed by treatment with 1,2-ethanediol in the presence of catalytic amount of an acid, produces a major product which is

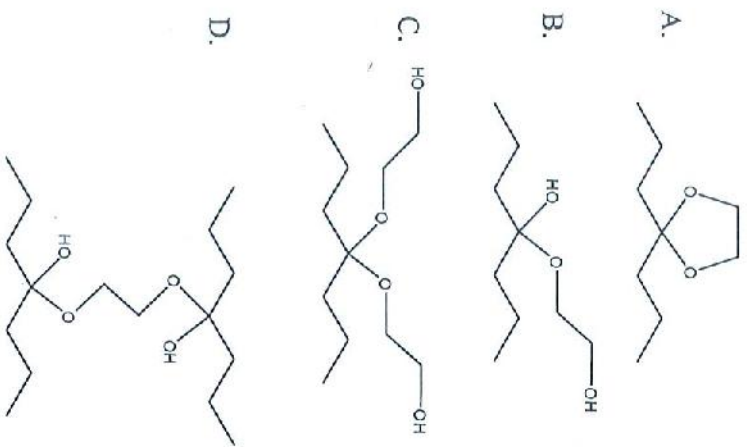

- 110 XeF_6 on complete hydrolysis yields 'X'. The molecular formula of X and its geometry, respectively, are
- XeO_2 and linear
 - XeO_3 and trigonal planar
 - XeO_3 and pyramidal
 - XeO_4 and tetrahedral

40

BIOLOGY

111 Following the cell cycle scheme given below, what is the probability that a cell would be in M-phase at any given time?

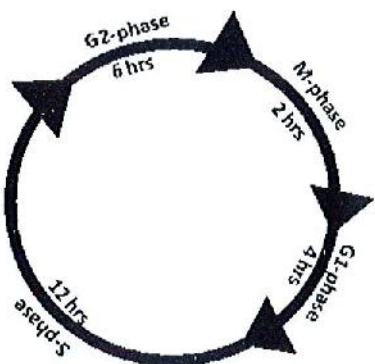

- 112 A flower with Tt genotype is cross-pollinated by TT pollens. What will the genotypes of the resulting endosperm and embryo, respectively, be?
- TTT, (TT + Tt)
 - (TTT + TtT), TT
 - TTt, Tt
 - TTt, (TT + Tt)

41

113 A new life form discovered on a distant planet has a genetic code consisting of five unique nucleotides and only one stop codon. If each codon has four bases, what is the maximum number of unique amino acids this life form can use?

- A. 624
- B. 20
- C. 124
- D. 3124

114 A spontaneous mutation results in a couple having only female progeny. When the daughter marries and has children, none of them are males. However, in the third generation there are few male offspring. What is the most likely explanation of this observation?

- A. The mutation reverses spontaneously in the third generation
- B. The mutation occurs on the X chromosome and is both recessive and lethal
- C. The mutation occurs on the X chromosome and is both recessive and dominant
- D. The mutation occurs on an autosome and is dominant

115 A circular plasmid of 10,000 base pairs (bp) is digested with two restriction enzymes, A and B, to produce a 3000 bp and a 2000 bp bands when visualised on an agarose gel. When digested with one enzyme at a time, only one band is visible at 5000 bp. If the first site for enzyme A (A1) is present at the 100th base, the order in which the remaining sites (A2, B1 and B2) are present is

- A. 3100, 5100, 8100
- B. 8100, 3100, 5100
- C. 5100, 3100, 8100
- D. 8100, 5100, 3100

116 After meiosis-II, daughter cells differ from the parent cells and each other in their genotypes. This can occur because of which one of the following mechanism(s)?

- A. Only synapctic crossing over
- B. Only crossing over and independent assortment of chromosomes
- C. Only crossing over and chromosomal segregation
- D. Crossing over, independent assortment and segregation of chromosomes

117 A desert lizard (an ectotherm) and a mouse (an endotherm) are placed inside a chamber at 15 °C and their body temperatures [T(L) for the lizard and T(M) for the mouse] and metabolic rates [M(L) for the lizard and M(M) for the mouse] are monitored. Which one of the following is correct?

- A. T(L) and M(L) will fall while T(M) and M(M) will increase
- B. T(L) and M(L) will increase while T(M) and M(M) will fall
- C. T(L) and M(L) will fall, T(M) will remain same and M(M) will increase
- D. T(L) and M(L) will remain same and T(M) and M(M) will decrease

118 In Griffith's experiments mice died when injected with

- A. heat killed S-strain
- B. heat killed S-strain combined with R-strain
- C. heat killed R-strain
- D. live R-strain

119 Human height is a multigenic character. If the heights of all the individuals living in a metropolis are measured and the percentages of the population belonging to a specific height are plotted as shown below, which of the plots would represent the most realistic distribution?

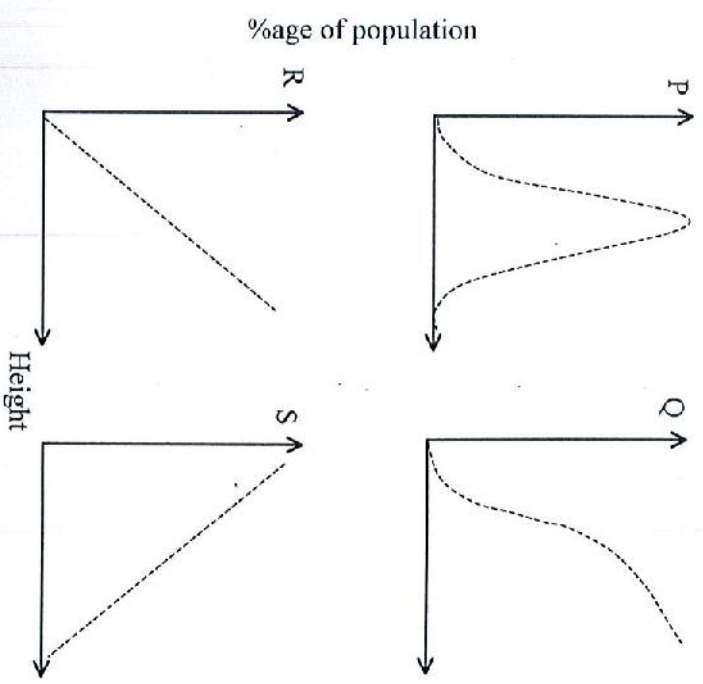

- A. P
- B. Q
- C. R
- D. S

120 If mitochondria isolated from a cell are first placed without carbon source in a buffer at pH 8.0 and then transferred to a buffer at pH 4, it will lead to

- A. an increase in intra-mitochondrial acidity
- B. a decrease in intra-mitochondrial acidity
- C. blockage of ATP synthesis
- D. synthesis of ATP

ROUGH WORK

46

ROUGH WORK

47

ROUGH WORK