



Rao IIT Academy

Symbol of Excellence and Perfection

JEE | MEDICAL-UG | BOARDS | KVPY | NTSE | OLYMPIADS

XII - ISC Board

Date: 20.02.2018

PHYSICS - SOLUTIONS

SECTION - A

Question 1

(A) Choose the correct alternative (a), (b), (c) or (d) for each of the questions.

(i) The order of coloured rings in a carbon resistor is red, yellow, blue and silver. The resistance of the carbon resistor is:

(a) $24 \times 10^6 \Omega \pm 5\%$

(b) $24 \times 10^6 \Omega \pm 10\%$

(c) $34 \times 10^4 \Omega \pm 10\%$

(d) $26 \times 10^4 \Omega \pm 5\%$

Ans. (b)

$$R = 24 \times 10^6 \Omega \pm 10\%$$

Topic: Current electricity_Subtopic: Colour coding of resistor Level: Easy_ISC Board / Physics

(ii) A circular coil carrying a current I has radius R and number of turns N. If all the three, i.e. the current I, radius R and number of turns N are doubled, then, magnetic field at its centre becomes:

(a) Double

(b) Half

(c) Four times

(d) One fourth

Ans. (a)

$$B = \frac{\mu_0 NI}{R}$$

Topic: Magnetic effect of current electricity & Magnetism_Subtopic: Magnetic field at centre of circular coil_Level: Medium_ISC Board / Physics

(iii) An object is kept on the principal axis of a concave mirror of focal length 10 cm. at a distance of 15 cm from its pole. The image formed by the mirror is:

(a) Virtual and magnified

(b) Virtual and diminished

(c) Real and magnified

(d) Real and diminished

Ans. (c)

$$\frac{1}{u} + \frac{1}{v} = \frac{1}{f}$$

$$u = -15, f = -10$$

$$\therefore v = -30$$

Topic: Optics_Subtopic: Mirror formula_Level: Easy_ISC Board / Physics

(iv) Einstein's photoelectric equation is:

$$(a) E_{\max} = h\lambda - \phi_0 \quad (b) E_{\max} = \frac{hc}{\lambda} - \phi_0 \quad (c) E_{\max} = h\nu + \phi_0 \quad (d) E_{\max} = \frac{h\nu}{\lambda} + \phi_0$$

Ans. (b)

$$\because h\nu = \phi_0 + E_{\max}$$

Topic: Dual nature of light_Subtopic: Einstein's equation_Level: Easy_ISC Board / Physics

(v) In Bohr's model of hydrogen atom, radius of the first orbit of an electron is r_0 . Then, radius of the third orbit is:

$$(a) \frac{r_0}{9} \quad (b) r_0 \quad (c) 3r_0 \quad (d) 9r_0$$

Ans. (d)

$$\because r_n = n^2 (r_0)$$

Topic: Atom / Nuclei_Subtopic: Bohr's Model_Level: Easy_ISC Board / Physics

(B) Answer the following questions briefly and to the point.

(i) In a potentiometer experiment, balancing length is found to be 120 cm for a cell E_1 of emf 2V. What will be the balancing length for another cell E_2 of emf 1.5V? (No other changes are made in the experiment.)

$$\text{Ans. } \frac{E_1}{E_2} = \frac{\ell_1}{\ell_2}$$

$$\frac{2}{1.5} = \frac{120}{\ell_2}$$

$$\ell_2 = 90 \text{ cm}$$

Topic: Current Electricity_Subtopic: Potentiometer_Level: Easy_ISC Board / Physics

(ii) How will you convert a moving coil galvanometer into a voltmeter?

Ans. By connecting high resistance in series.

Topic: Magnetic effect of current electricity & Magnetism_Subtopic: Voltmeter_Level: Easy_ISC Board / Physics

(iii) A moving charged particle q travelling along the positive x -axis enters a uniform magnetic field B . When will the force acting on q be maximum?

Ans. When charge particle sends perpendicular to field.

Topic: Magnetic effect of current electricity & Magnetism_Subtopic: Force on charged particle_Level: Easy_ISC Board / Physics

(iv) Why is the core of a transformer laminated?

Ans. To reduce eddy current losses.

Topic: Electromagnetic Induction/AC_Subtopic: Eddy current_Level: Easy_ISC Board / Physics

- (v) Ordinary (i.e. unpolarised) light is incident on the surface of a transparent material at the polarising angle. If it is partly reflected and partly refracted, what is the angle between the reflected and the refracted rays?

Ans. 90° , Brewster's law.

Topic: Optics_Subtopic: Brewster's law_Level: Easy_ISC Board / Physics

- (vi) Define coherent sources of light.

Ans. Sources must have zero or constant phase difference.

Topic: Optics_Subtopic: Coherent sources_Level: Easy_ISC Board / Physics

- (vii) Name a material which is used in making control rods in a nuclear reactor.

Ans. Boron, Silver, Indium and Cadmium.

Topic: Atoms/Nuclei_Subtopic: Nuclear reactor_Level: Medium_ISC Board / Physics

SECTION B

Question 2

Define current density. Write an expression which connects current density with drift speed.

Ans. Current density is defined as current per unit cross section area of conductor.

$$\vec{J} = \frac{I}{A}$$

Relation

$$\vec{J} = n e \vec{V} d$$

$n \rightarrow$ electron density.

Topic: Current Electricity_Subtopic: Current Density_Level: Easy_ISC Board / Physics

Question 3

- (a) A long horizontal wire P carries a current of 50A. It is rigidly fixed. Another wire Q is placed directly above and parallel to P, as shown in Figure 1 below. The weight per unit length of the wire Q is 0.025 Nm^{-1} and it carries a current of 25A. Find the distance 'r' of the wire Q from the wire P so that the wire Q remains at rest.

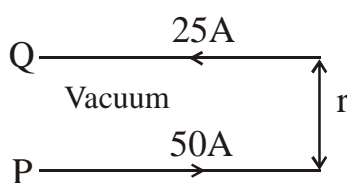

Figure 1

Ans.
$$\frac{F}{\ell} = \frac{\mu_0}{4\pi} \frac{2I_1 I_2}{r}$$

$$0.025 = 10^{-7} \times \frac{2 \times 50 \times 25}{r}$$

$$\boxed{r = 0.01 \text{ m}}$$

Topic: Magnetic effect of current electricity & Magnetism_Subtopic: Force / Length due to two parallel current carrying conductors_Level: Medium_ISC Board / Physics

OR

- (b) Calculate force per unit length acting on the wire B due to the current flowing in the wire A. (See Figure 2 below)

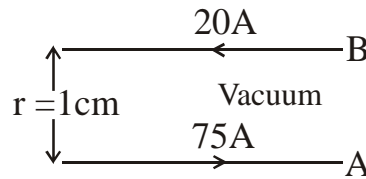

Figure 2

Ans.
$$\frac{F}{\ell} = \frac{\mu_0}{4\pi} \frac{2I_1 I_2}{r}$$

$$10^{-7} \times \frac{2 \times 20 \times 25 \times 75}{0.01}$$

$$= \boxed{0.03 \text{ N/m}}$$

Topic: Magnetic effect of current electricity & Magnetism _Subtopic: Force / Length due two parallel current carrying conductor _ Level:Medium_ISC Board / Physics

Question 4

- (i) Explain Curie's law for a paramagnetic substance.
 (ii) A rectangular coil having 60 turns and area of 0.4 m^2 is held at right angles to a uniform magnetic field of flux density $5 \times 10^{-5} \text{ T}$. Calculate the magnetic flux passing through it.

Ans. (i) Magnetic susceptibility inversely proportional to temperature.

$$I_m \propto B$$

$$I_m \propto \frac{1}{T}$$

$$\therefore I_m \propto \frac{B}{T}$$

$$I_m = \frac{CB}{T}$$

$$I_m = \frac{C \cdot \mu \cdot H}{T}$$

$$\frac{I_m}{H} = \frac{C\mu}{T}$$

$$\chi = \frac{C}{T}$$

$$\therefore \chi \propto \frac{1}{T}$$

Topic: Magnetic effect of current electricity & Magnetism _Subtopic: Curie law _ Level:Easy_ISC Board / Physics

$$\begin{aligned}
 \text{(ii)} \quad \phi &= NBA \\
 &= 60 \times 5 \times 10^{-5} \times 0.4 \\
 &= 120 \times 10^{-5} \text{ Wb}
 \end{aligned}$$

Topic: Electromagnetic induction/AC **_Subtopic:** Magnetic flux_ **Level:** Easy_ISC Board / Physics

Question 5

What is motional emf? State any two factors on which it depends.

Ans. Induced EMF by change of area of the coil linked with magnetic field.

$$e = Bvl$$

It depends on

- (i) Magnetic field
- (ii) Velocity of conductor
- (iii) Length of conductor

Topic: Electromagnetic induction/AC **_Subtopic:** Induced EMF_ **Level:** Easy_ISC Board / Physics

Question 6

- (i) What is the ratio of the speed of gamma rays to that of radio waves in vacuum?
- (ii) Name an electromagnetic wave which is used in the radar system used in aircraft navigation.

Ans. (i) 1

Topic: Electromagnetic waves **_Subtopic:** Speed of EMW_ **Level:** Easy_ISC Board / Physics

- (ii) Microwaves or Radio waves

Topic: Electromagnetic waves **_Subtopic:** Uses of EMW_ **Level:** Easy_ISC Board / Physics

Question 7

A biconvex lens made of glass (refractive index 1.5) has two spherical surfaces having radii 20 cm and 30 cm. Calculate its focal length.

$$\text{Ans.} \quad \frac{1}{f} = (\mu - 1) \left(\frac{1}{R_1} + \frac{1}{R_2} \right)$$

$$\frac{1}{f} = (1.5 - 1) \left(\frac{1}{30} + \frac{1}{20} \right)$$

$$f = 24 \text{ cm}$$

Topic: Optics **_Subtopic:** Convex Lens_ **Level:** Easy_ISC Board / Physics

Question 8

State any two difference between primary rainbow and secondary rainbow.

Ans. In primary rainbow, intensity of colours are more as compared to secondary rainbow.

Primary rainbow lies below the secondary rainbow.

Topic: Optics **_Subtopic:** Rainbow_ **Level:** Easy_ISC Board / Physics

Question 9

- (i) State de Broglie hypothesis.
 (ii) With reference to photoelectric effect, define threshold wavelength.

Ans. (i) According to de Broglie a moving material particle acts as a wave and sometimes wave is associated with moving material particle which controls the particle in every respect.

$$\lambda = \frac{h}{p}$$

Topic: Dual nature of light_Subtopic: de Broglie hypothesis_Level:Easy_ISC Board / Physics

- (ii) Maximum wavelength of incident radiation required to eject electron from photo sensitive surface.

Topic: Dual nature of light_Subtopic: Threshold wavelength_Level:Medium_ISC Board / Physics

Question 10

Calculate the minimum wavelength of the spectral line present in Balmer series of hydrogen.

$$\text{Ans. } \frac{1}{\lambda} = R \left[\frac{1}{n_1^2} - \frac{1}{n_2^2} \right]$$

$$\frac{1}{\lambda} = R \left[\frac{1}{2^2} - \frac{1}{\infty^2} \right]$$

$$\therefore \frac{1}{\lambda} = \frac{R}{4}$$

$$\lambda = \frac{4}{R}$$

$$\lambda = \frac{4}{10.97 \times 10^6} = 0.37 \times 10^{-6}$$

$$\lambda = 3700 \text{ \AA}$$

Topic: Atoms/Nuclei_Subtopic: Energy spectrum_Level:Medium_ISC Board / Physics

Question 11

- (a) What is means by pair annihilation ? Write a balanced equation for the same.

OR

- (b) What is meant by the terms half-life of a radioactive substance and binding energy of a nucleus ?

Ans. (a) When particle meets it anti particle, the two annihilate to form photon.

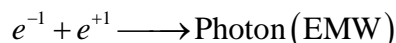

Topic: Atoms/Nuclei_Subtopic: Pair annihilation_Level:Easy_ISC Board / Physics

- (b) Half-life period - It is time in which half of radio active substance disintegrate from its original value.

Binding energy is energy required to seperate Nucleons from nucleus.

Topic: Atoms/Nuclei_Subtopic: Half life period & BE_Level:Easy_ISC Board / Physics

Question 12

In a communication system, what is meant by modulation? State any two types of modulation.

Ans. Superimposition of low frequency message signal on high frequency carrier wave called modulation.

1. Amplitude modulation (AM)

2. Frequency modulation (FM)

Topic: Communication system_Subtopic: Modulation_Level:Easy_ISC Board / Physics

Section C

Answer all questions

Question 13

Obtain an expression for intensity of electric field at a point in end on position, i.e., axial position of an electric dipole.

Ans. Consider an electric dipole consisting of charges $-q$ and $+q$ separated by a small distance $2r$ in free space.

Let P be a point on the axial line of the dipole at a distance x from the centre O of the dipole (i.e., $OP = x$)

Electric field intensity at point P due to $+q$ charge,

$$E_1 = \frac{1}{4\pi\epsilon_0} \cdot \frac{q}{AP^2} \quad (\text{direction } A \text{ to } P)$$

$$E_1 = \frac{1}{4\pi\epsilon_0} \cdot \frac{q}{(x+r)^2} \quad (\text{direction } A \text{ to } P) \quad \dots(i)$$

Electric field intensity at point P due to $-q$ charge,

$$E_2 = \frac{1}{4\pi\epsilon_0} \cdot \frac{q}{BP^2} \quad (\text{direction } P \text{ to } B)$$

$$E_2 = \frac{1}{4\pi\epsilon_0} \cdot \frac{q}{(x-r)^2} \quad (\text{direction } P \text{ to } B) \quad \dots(ii)$$

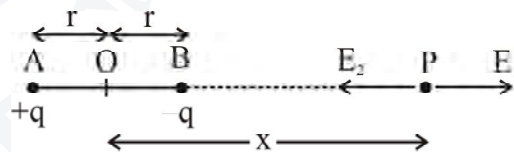

Since $E_2 > E_1$ and they act in opposite directions, resultant field intensity is given by :

$$E = E_2 - E_1 \quad (\text{direction } P \text{ to } B)$$

$$= \frac{1}{4\pi\epsilon_0} \cdot \frac{q}{(x-r)^2} - \frac{1}{4\pi\epsilon_0} \cdot \frac{q}{(x+r)^2}$$

$$= \frac{1}{4\pi\epsilon_0} \cdot q \left[\frac{1}{(x-r)^2} - \frac{1}{(x+r)^2} \right]$$

$$= \frac{1}{4\pi\epsilon_0} \cdot q \left[\frac{(x+r)^2 - (x-r)^2}{(x-r)^2 (x+r)^2} \right]$$

$$= \frac{1}{4\pi\epsilon_0} \cdot q \left[\frac{(x+r+x-r)(x+r-x+r)}{(x^2-r^2)^2} \right]$$

$$= \frac{1}{4\pi\epsilon_0} \cdot q \left[\frac{2x \cdot 2r}{(x^2 - r^2)^2} \right]$$

$$E = \frac{1}{4\pi\epsilon_0} \cdot \frac{2xp}{(x^2 - r^2)^2} \quad [\because p = 2r \cdot q]$$

If the dipole is short (i.e., $r \ll x$) then r^2 may be neglected as compared to x^2 .

$$E = \frac{1}{4\pi\epsilon_0} \cdot \frac{2p}{x^3}$$

The direction of resultant electric field E is along the dipole axis i.e., from $-q$ charge to $+q$ charge.

Topic: Electrostatics_Subtopic: Electric intensity due to the dipole_Level:Medium_ISC Board / Physics

Question 14

Deduce an expression for equivalent capacitance C when three capacitors C_1 , C_2 and C_3 connected in parallel.

Ans. Expression for effective capacitance in parallel grouping of capacitors :

Consider three capacitors of capacitance C_1 , C_2 and C_3 are connected in parallel.

Let Q_1 , Q_2 and Q_3 be the charges deposited on the capacitors as shown in the figure.

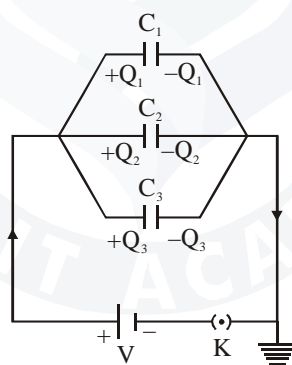

Suppose a potential difference 'V' is applied across the combination. Then, the potential difference between the plates of each capacitors is V but charges on each capacitors are different. Since different current flows through different branches, so the charges are given by

$$Q_1 = C_1V, Q_2 = C_2V, Q_3 = C_3V \quad \dots(i)$$

From the principle of conservation of charge,

$$Q = Q_1 + Q_2 + Q_3$$

$$Q = C_1V + C_2V + C_3V \quad \text{[From equation (i)]}$$

$$\therefore Q = V(C_1 + C_2 + C_3) \quad \dots(ii)$$

If these capacitors are replaced by a single capacitor of capacity C_p such that $Q = C_pV$ then using equation (ii) we have,

$$C_pV = V(C_1 + C_2 + C_3)$$

$$C_p = C_1 + C_2 + C_3$$

Topic: Electrostatics_Subtopic: Total capacitance of capacitors_Level:Easy_ISC Board / Physics

Question 15

- (a) ε_1 and ε_2 are two batteries having emf of 34V and 10V respectively and internal resistance of 1Ω and 2Ω respectively. They are connected as shown in figure below. Using Kirchoff's Laws of electrical networks, calculate the currents I_1 and I_2 .

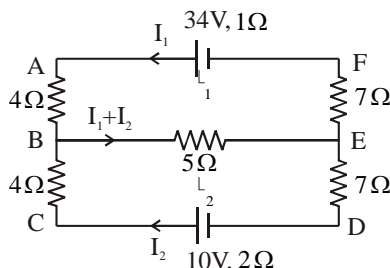

- (b) An electrical bulb is marked 200V, 100W. Calculate electrical resistance of its filament. If five such bulbs are connected in series to a 200V supply, how much current will flow through them ?

Ans.

- (a) By Kirchoff's law of electrical networks consider closed loop ABEFA

$$\therefore -4I_1 - 5(I_1 + I_2) - 7I_1 - I_1 + 34 = 0$$

$$\therefore -4I_1 - 5I_1 - 5I_2 - 7I_1 - I_1 = -34$$

$$\therefore -17I_1 - 5I_2 = -34$$

$$\therefore 17I_1 + 5I_2 = 34 \quad \dots(1)$$

Consider closed loop BCDEB,

$$4I_2 - 10 + 2I_2 + 7I_2 + 5(I_1 + I_2) = 0$$

$$\therefore 4I_2 + 2I_2 + 7I_2 + 5I_1 + 5I_2 = 10$$

$$18I_2 + 5I_1 = 10 \quad \dots(2)$$

Multiply equation (1) by 5 and equation (2) by 17 and Subtract

$$65I_1 + 25I_2 = 170$$

$$\underline{-65I_1 + 306I_2 = 170}$$

$$331I_2 = 0 \Rightarrow I_2 = 0$$

$$\therefore I_1 = 2A$$

Topic: Current electricity_Subtopic: Kirchoffs law_Level:Medium_ISC Board / Physics

- (b) Voltage $V = 200V$, Power $P = 100W$

$$\therefore \text{Electrical current} = \frac{P}{V} = \frac{100}{200} = \frac{1}{2} \text{ Amp}$$

$$\therefore \text{Electrical resistance } R = \frac{V}{I} = \frac{200}{1/2} = 400\Omega$$

if five bulbs are connected in series to 200V

$$\therefore \text{Total resistance } R_T = 400 + 400 + 400 + 400 + 400 = 2000\Omega$$

$$\text{Current flowing through a bulb } I = \frac{200}{2000} = 0.1A$$

Topic: Current electricity_Subtopic: Power, Ohm's law_Level:Medium_ISC Board / Physics

Question 16

(a) For any prism, prove that :

$$'n' \text{ or } \mu = \frac{\sin\left(\frac{A + \delta_m}{2}\right)}{\sin\left(\frac{A}{2}\right)}$$

where the terms have their usual meaning.

(b) When two thin lenses are kept in contact, prove that their combined or effective focal length F is given by :

$$\frac{1}{F} = \frac{1}{f_1} + \frac{1}{f_2}$$

where the terms have their usual meaning.

Ans.

(a) In the figure, a ray of light PQ is incident at an angle i on the face AB of prism ABC . This ray is refracted along QR at an angle r . This reflected ray is incident on the face AC at an angle r' and emerges along RS at an angle i' .

In $\triangle QDR$,

$$\delta = (i - r) + (i' + r')$$

$$= (i + i') - (r + r') \quad \dots(i)$$

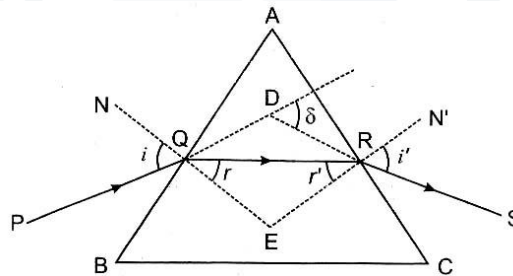

In Quad. $AQER$, $A + E = 180^\circ \quad \dots(ii)$

In $\triangle QER$ $r + r' + E = 180^\circ \quad \dots(iii)$

$\therefore r + r' = A \quad [From eq. (ii) and (iii)]$

Putting value of $r + r'$ in equation (i),

$$\delta = i + i' - A$$

In the position of minimum deviation condition,

$$i = i', r = r', \delta = \delta_m$$

$$So r + r' = A$$

$$2r = A$$

$$or r = \frac{A}{2}$$

$$\delta_m = 2i - A$$

$$i = \frac{A + \delta_m}{2}$$

Putting value of i and r from (v), (vi), in Snell's law,

$$n = \frac{\sin i}{\sin r}$$

$$n = \frac{\sin\left(\frac{A + \delta_m}{2}\right)}{\sin\left(\frac{A}{2}\right)}$$

Topic: Optics_Subtopic: Prism formula_Level:Medium_ISC Board / Physics

(b)

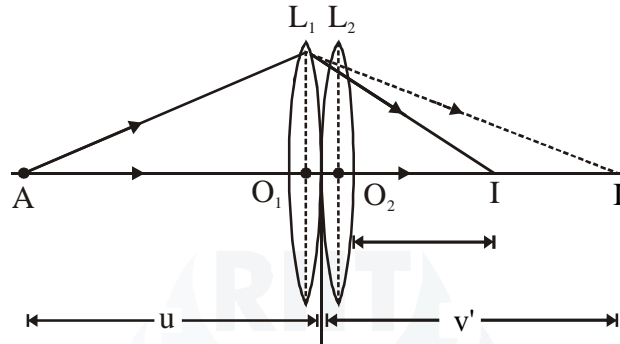

(i) Image is formed in two steps :

In the first step, the lens L_1 produces image I' of the object A . It is a real image at a distance v' from L_1 .

Then for the lens L_1 , we have,

$$\frac{1}{v'} + \frac{1}{-u} = \frac{1}{f_1}$$

$$\therefore \frac{1}{v'} - \frac{1}{u} = \frac{1}{f_1} \quad \dots(1)$$

(ii) In the second step, the image I' acts as an object for L_2 and the final image I is formed. The image I' is not observed, hence it acts a virtual object for lens L_2 it is assumed to be kept on left, we can write for L_2 .

$$\frac{1}{v} + \frac{1}{-v'} = \frac{1}{f_2}$$

$$\therefore \frac{1}{v} - \frac{1}{v'} = \frac{1}{f_2} \quad \dots(2)$$

(iii) Adding equations (1) and (2), we get

$$\frac{1}{v'} - \frac{1}{u} + \frac{1}{v} - \frac{1}{v'} = \frac{1}{f_1} + \frac{1}{f_2}$$

$$\therefore \frac{1}{v} - \frac{1}{u} = \frac{1}{f_1} + \frac{1}{f_2} \quad \dots(3)$$

(iv) If a single lens of focal length f of equivalent lens is used for object A and corresponding image I is formed then we have,

$$\frac{1}{v} + \frac{1}{-u} = \frac{1}{f} \quad \dots(4)$$

(v) From equations (3) and (4),

$$\frac{1}{f} = \frac{1}{f_1} + \frac{1}{f_2} \quad \dots(5)$$

Topic: Optics_Subtopic: Combination of lenses_Level:Medium_ISC Board / Physics

Question 17

(i) In **Young's** double slit experiment, show graphically how intensity of light varies with distance.

Sol.

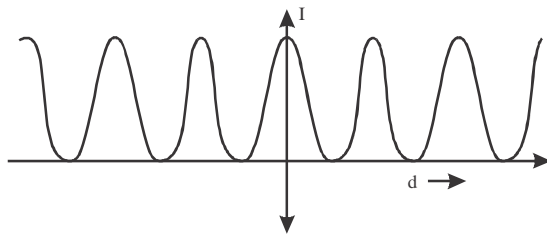

I - Intensity

d - Distance

The above graph shows the intensity versus distance. The intensity of light does not vary with the distance.

Topic: Optics_Subtopic: Young's double slit_Level:Easy_ISC Board / Physics

(ii) In Fraunhofer diffraction, how is the angular width of the central bright fringe affected when slit separation is increased?

Sol. In Fraunhofer diffraction at a single slit, we obtain a central bright band, having on both sides narrower alternately dark and bright bands of decreasing intensity.

Finer the slit, broader is the diffraction pattern and wider is the central band as shown in the given figure.

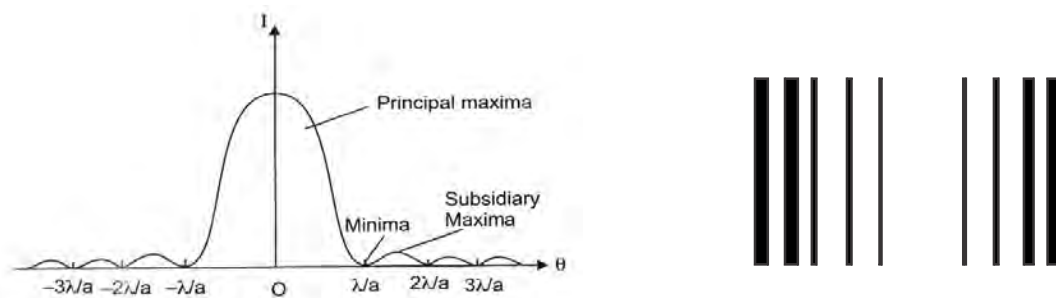

Topic: Optics_Subtopic: Fraunhofer diffraction_Level:Medium_ISC Board / Physics

Question 18

Write one balanced equation each to show :

- (i) Nuclear fission
- (ii) Nuclear fusion
- (iii) Emission of β^- (i.e. a negative beta particle)

Sol.

(i) Nuclear Fission :

When a slow neutron strikes ${}_{92}\text{U}^{235}$ nucleus, it is absorbed by the nucleus and an isotope U^{236} is formed. But U^{236} , being highly unstable, is immediately broken into two fragments and emits neutrons and energy. This fission can be represented by the following equation :

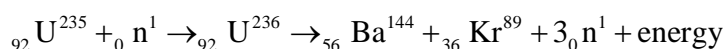
**(ii) Nuclear fusion :**

The fusion of two nuclei of heavy hydrogen or deuterium (${}^2\text{H}$), the following is possible

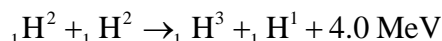
**(iii) Emission of β^- (i.e. a negative beta particle) :**

When an energetic γ - ray photon falls on heavy substance, it is absorbed by some nucleus of the substance, and its energy give rise to the production of an electron and a positron. This phenomenon in which energy is converted into mass is called pair production.

Equation :

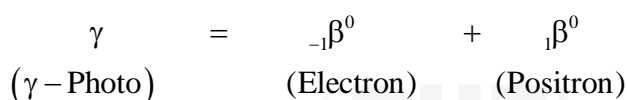

Topic: Atoms & Nuclear_Subtopic: Nuclear reaction_Level:Medium_ISC Board / Physics

Question 19

With reference to semi conductor devices, define a p - type semiconductor and a Zener diode.

What is the use of Zener diode ?

Sol. When a trivalent impurity like aluminium, indium, boron, gallium, etc., is doped with pure germanium (or silicon) , then the conductivity of the crystal increases due ot deficiency of electrons i.e., holes and such a crystal is said to be p- type semiconductor while the impurity atoms are called acceptors. A Zener diode is a reverse biased heavily doped p - n junction diode, which is operated in break-down region, where the current is limited by both external resistance and power dissipation of the diode.

Zener diode is used to stabilize voltage in circuit.

Topic: Electronic Devices_Subtopic: Semi conductor_Level:Medium_ISC Board / Physics

Section D**Answer all questions****Question 20**

(a) An alternating emf of 220 V is applied to a circuit containig a resistor R having resistance of 160Ω and a capacitor 'C' is series. The current is found to lead the supply voltage by an angle

$$\theta = \tan^{-1} (3/4) .$$

- (i) Calculate : (1) The capacitive reactance
(2) Impedance of the circuit
(3) Current flowing in the circuit

(ii) If the frequency of the applied emf is 50 Hz, what is the value of the capacitance of the capacitor 'C' ?

Ans.

(a) $E = 220 \text{ V}$, $R = 160$, $C = \text{Capacitor}$

Current leads voltage by $\phi = \tan^{-1}\left(\frac{3}{4}\right)$

Find : X_C , Z , I

(i) Given $\theta = \tan^{-1}\left(\frac{3}{4}\right)$... (1)

but $\theta = \tan^{-1}\left(\frac{X_C}{R}\right)$... (2)

From (1) and (2)

$$\tan \theta = \frac{3}{4}$$

$$\text{but } \tan \theta = \frac{X_C}{R}$$

$$\therefore \frac{3}{4} = \frac{X_C}{R}$$

$$\therefore R = 160$$

$$\therefore \frac{3}{4} = \frac{X_C}{160}$$

$$\therefore X_C = \frac{3}{4} \times 160$$

$$X_C = 3 \times 40$$

$$X_C = 120 \Omega$$

$$\begin{aligned} \text{Impedance } Z &= \sqrt{R^2 + X_C^2} \\ &= \left[(160)^2 + (120)^2 \right]^{1/2} \\ Z &= 200 \Omega \end{aligned}$$

$$I_0 = \frac{V}{Z} = \frac{220}{200} = 1.1 \text{ A} \Rightarrow I_0 = 1.1 \text{ A}$$

(ii) $f = 50 \text{ Hz}$

$$X_C = 120 \Omega$$

$$X_C = \frac{1}{2\pi fC}$$

$$\therefore C = \frac{1}{(2\pi f) \times (X_C)} = \frac{1}{2\pi \times 50 \times 120} = 2.65 \times 10^{-5} \text{ F} = 26.5 \mu\text{F}$$

$$C = 26.5 \mu\text{F}$$

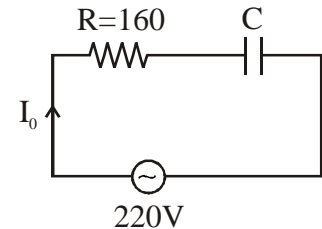

Topic: Electromagnetic induction and A.C. circuits_Subtopic: AC circuits Level:Medium_ISC Board / Physics

- (b) An A.C. generator generating an emf of $\varepsilon = 300 \sin(100 \pi t)$ V is connected to a series combination of $16 \mu F$ capacitor, 1 H inductor and 100Ω resistor.

Calculate :

- (i) Impedence of the circuit at the given frequency.
- (ii) Resonant frequency f_0 .
- (iii) Power factor at resonant frequency f_0 .

Sol. $E = 300 \sin(100 \pi t)$

$C = \text{capacitor} = 16 \mu F$

$L = \text{Inductar} = 1H$

$R = 100 \Omega$

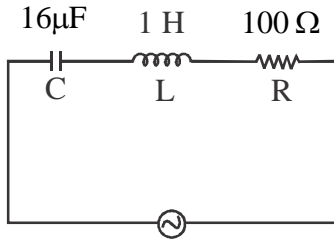

$E = 300 \sin(100 \pi t)$

From $E = 300 \sin(100 \pi t)$

$\omega = 100 \pi$

$2\pi f = 100 \pi$

$\therefore f = 50 \text{ Hz}$

$\therefore X_C = \frac{1}{2\pi f C} = \frac{1}{2\pi \times 50 \times 16 \times 10^{-6}} = \frac{1}{5026.5 \times 10^{-6}} = 1.98 \times 10^{-4} \times 10^6$

$\therefore X_C = 198 \Omega$

$X_L = 2\pi f L = 2\pi \times 50 \times 1 = 314.1 \Omega$

- (i) Impedence of the circuit (Z)

$$\begin{aligned} Z &= \sqrt{R^2 + (X_L - X_C)^2} \\ &= \left[(100)^2 + (314 - 198)^2 \right]^{1/2} \\ &= 153.15 \Omega \end{aligned}$$

- (ii) Resonant frequency (f_0)

$$f_0 = \frac{1}{2\pi \sqrt{LC}}$$

$$= \frac{1}{2\pi\sqrt{1 \times 16 \times 10^{-6}}}$$

$$= 39.84\text{Hz}$$

(iii) at Resonance $X_C = X_L$

$$\therefore Z = R$$

$$\cos \phi = \frac{R}{Z}$$

$$\cos \phi = \frac{R}{R}$$

$$\cos \phi = 1$$

power factor ($\cos \phi$) = 1

Topic: Electromagnetic Induction_Subtopic: AC circuit_Level:Medium_ISC Board / Physics

Question 21

(a) Draw a labelled ray diagram of an image formed by a **refracting telescope** with final image formed at **infinity**. Derive an expression for its magnifying power with the final image at infinity.

Sol.

(a)

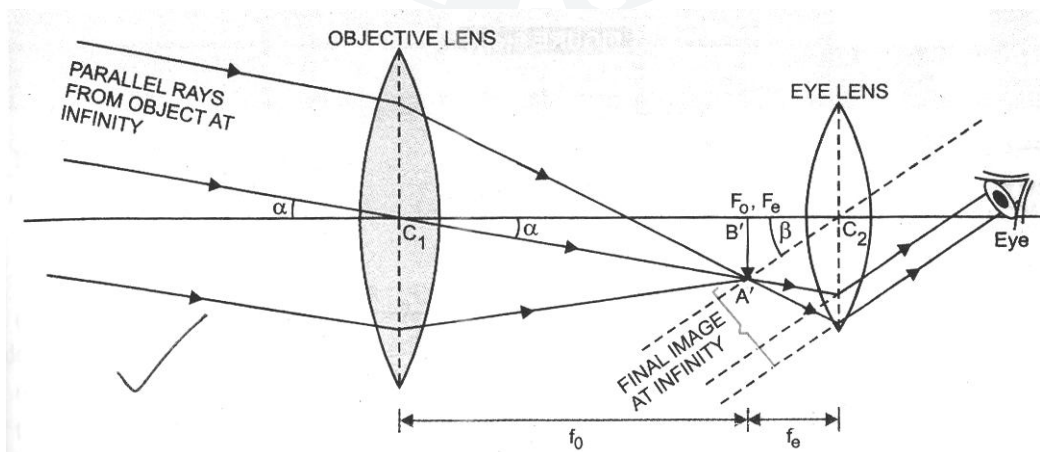

As the object lies at very huge distance, therefore, angle subtended by the object at C_2 (where eye is held) is almost the same as the angle subtended by the object at C_1 (because C_1 is close to C_2). Let it be α , i.e. $\angle A'C_1B' = \alpha$. Rays coming from the final image at infinity make $\angle A'C_2B' = \beta$ on the eye. Therefore, by definition,

$$\text{Magnifying power, } m = \frac{\beta}{\alpha} \quad \dots(1)$$

As angles α and β are small, therefore, $\alpha = \tan \alpha$ and $\beta = \tan \beta$.

From (1),
$$m = \frac{\tan \beta}{\tan \alpha} \quad \dots\dots(2)$$

In $\Delta A'B'C_2$,
$$\tan \beta = \frac{A'B'}{C_2B'}$$

In $\Delta A'B'C_1$,
$$\tan \alpha = \frac{A'B'}{C_1B'}$$

Put in (2),
$$m = \frac{A'B'}{C_2B'} \times \frac{C_1B'}{A'B'} = \frac{C_1B'}{C_2B'} \quad \text{or} \quad m = \frac{f_0}{-f_e} \quad \dots(3)$$

where $C_1B' = f_0 =$ focal length of objective lens, $C_2B' = -f_e =$ focal length of eye lens.

Negative sign of m indicates the final image is inverted w.r.t. the object.

Topic: Optics_Subtopic: Refracting telescope_Level:Medium_ISC Board / Physics

OR

- (b) (i) Using **Huygen’s** wave theory, derive **Snell’s** law of refraction.
- (ii) With the help of an experiment, state how will you identify whether a given beam of light is polarised or unpolarised.

Sol.

(i) **Laws of Refraction :** Consider a plane wave front AB incident on a surface PQ separating two media (1) and (2). The media (1) is rarer, having refractive index n_1 , in which the light travels with a velocity c_1 . The medium (2) is denser, having refractive index n_2 , in which the light travels with a velocity c_2 .

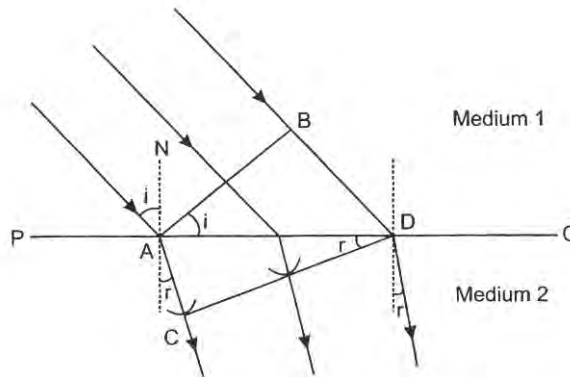

At time $t = 0$, the incident wave front AB touches the boundary separating two medium at A. The secondary wavelets from point B advance forward with a velocity c_1 , and after time t seconds touches at D, thus covering a distance $BD = c_1 t$. In the same time interval of t seconds, the secondary wavelets from A, advance forward in the second an envelope is drawn to obtain a new refracted wave front as CD.

Consider triangle BAD and ACD,

$$\sin i = \sin(\angle BAD) = \frac{BD}{AD} = \frac{c_1 t}{AD}$$

$$\sin r = \sin(\angle ADC) = \frac{AC}{AD} = \frac{c_2 t}{AD}$$

$$\Rightarrow \frac{\sin i}{\sin r} = \frac{c_1 t}{c_2 t} = \frac{c_1}{c_2}$$

$$\Rightarrow \frac{\sin i}{\sin r} = \frac{c_1}{c_2} = \text{constant}$$

This constant is called the refractive index of the second medium with respect to the first medium.

$$\frac{c_1}{c_2} = \frac{n_2}{n_1}$$

$$\therefore \frac{\sin i}{\sin r} = \frac{c_1}{c_2} = \frac{n_2}{n_1} = {}_1 n_2$$

This is known as the Snell's law.

Topic: Optics_Subtopic: Snell's law_Level:Medium_ISC Board / Physics

(ii)

Detection of plane polarised light : Naked eyes or the polariser alone cannot make distinction between unpolarised light and plane polarised light. To analyse the nature of light, another crystal (analyser) is used. The tourmaline crystal is used to produce plane polarised light.

If the polariser is rotated in the path of the ordinary light, the intensity of the light transmitted from the polariser remains unchanged. It is because, in each orientation of the polariser, the plane polarised light is obtained, which has vibrations in a direction parallel to the axis of the crystal in that orientation. If the analyser is rotated in the path of the light transmitted from the polariser, so that the axis of the polariser and the analyser are parallel to each other, then the intensity of light is found to remain unaffected [see figure]

If the axis of the polariser and the analyser are perpendicular to each other as shown in figure, then the intensity of light becomes minimum.

In this position the polariser and the analyser are said to be in crossed position.

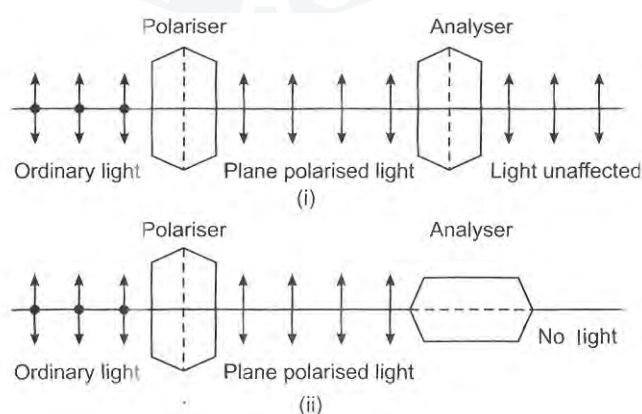

Topic: Optics_Subtopic: Polarisation_Level:Medium_ISC Board / Physics

Question 22

(a) (i) The forward characteristic curve of a junction diode is shown in Figure 4 below :

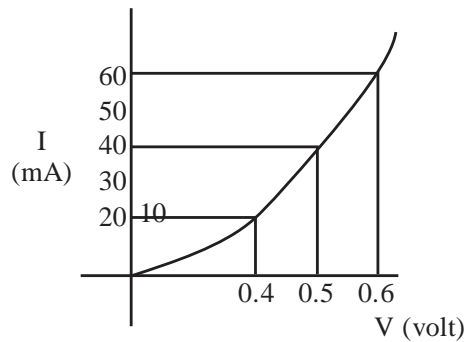

Figure 4

Calculate the resistance of the diode at :

(1) $V = 0.5 \text{ V}$

(2) $I = 60 \text{ mA}$

(ii) Draw separate energy band diagram for conductors, semi-conductors and insulators and label each of them.

Sol.

(a)

Resistance of Diode

(i) $V = 0.5 \text{ V}$

At $V = 0.5 \text{ V}$, $I = 40 \text{ mA}$

We know that $V = IR$

$$\therefore R = \frac{V}{I} = \frac{0.5}{40 \times 10^{-3}} = 12.5 \Omega$$

$\therefore I = 60 \text{ mA}$

we get $V = 0.6$

$$\therefore R = \frac{V}{I} = \frac{0.6}{60 \times 10^{-3}} = 10 \Omega$$

Topic: Electronic Devices_Subtopic: Diodes_Level:Medium_ISC Board / Physics

(ii) Energy Band Diagrams :-

Conductors

Here conduction Band and valance Band are partly overlapped.

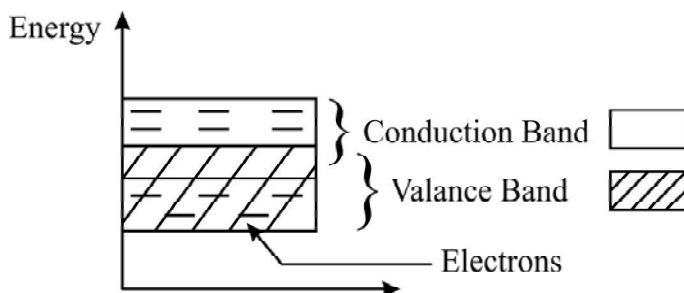

Insulators

Here forbidden gap is large between conduction Band and Valance Band.

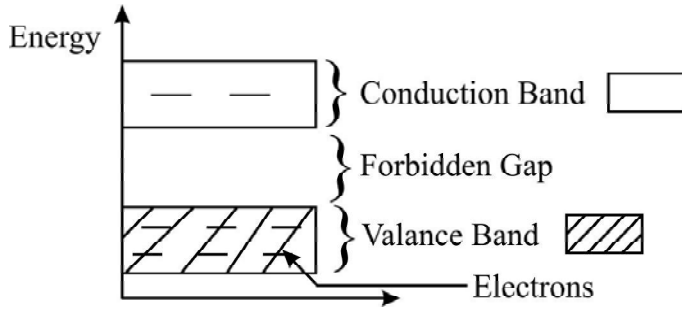

Semiconductors
Here forbidden gap is less than 1 eV

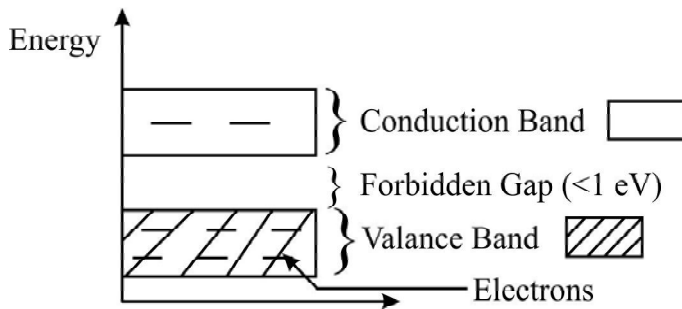

Topic: Electronic Devices_Subtopic: Energy Levels_Level:Medium_ISC Board / Physics

OR

(b) (i) The arrangement give below represents a logic gate :

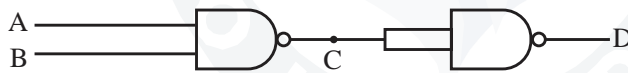

Copy the following truth table in your answer booklet and complete it showing outputs at C and D.

A	B	C	D
0	0		
1	0		
0	1		
1	1		

(ii) Draw a labelled diagram of a common **emitter amplifier**, showing waveforms of signal voltage and output voltage.

Sol. (b)
(i)

A	B	C	D
0	0	1	0
1	0	1	0
0	1	1	0
1	1	0	1

Topic: Electronic Devices_Subtopic: Logic gates_Level:Easy_ISC Board / Physics

(ii)

Common Emitter Amplifier

Common emitter Amplifier using n-p-n transistor as below.

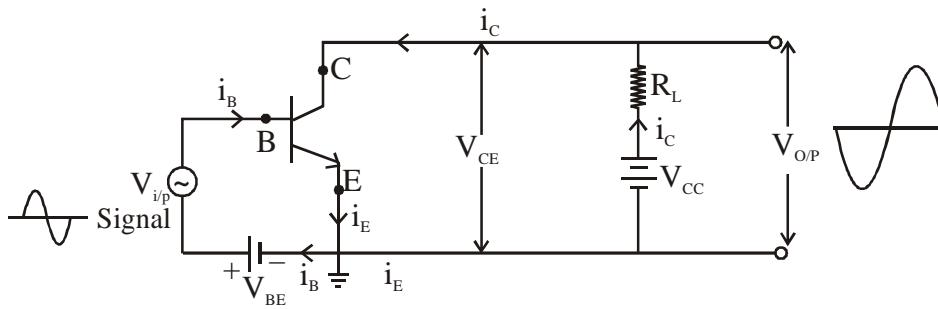

Topic: Electronic Devices_Subtopic: Amplifiers_Level:Medium_ISC Board / Physics

Useful Constants and Relations :

1. Permeability of vacuum (μ_0) = $4\pi \times 10^{-7} H m^{-1}$
2. Rydberg's constant (R) = $1.097 \times 10^7 m^{-1}$
