



- Note:** 1) Question paper has **four** parts **A, B, C** and **D**.
2) Part - **A** is **compulsory**.
3) Part - **D** has **two** parts. Part- **I** is from **problems**.
Part- **II** is of **essay type** questions.
4) Circuit diagrams/timing diagrams/truth tables are drawn **wherever** necessary.
5) Problems without **necessary** formula/formulae carry **no mark**.

PART- A

II. Answer all questions:

(10x1=10)

1. What is a DC load line?
2. Name any one non-linear application of op-amp.
3. Mention the intermediate frequency of AM receiver?
4. Amplitudes of carrier and signal voltages are 1V and 0.5V respectively, determine maximum voltage.
5. Name the device used in controlled rectifier.
6. Write the Boolean equation for the output of XOR gate.
7. Convert $(1101)_{\text{gray}}$ into binary.
8. Write any one logical instruction for 8051.
9. Expand ASCII.
10. What is a transponder?

PART- B

II. Answer any FIVE questions:

(5 x 2 =10)

11. Write the circuit symbol of n -channel and p-channel JFET?
12. Write the steps involved in drawing Dc equivalent circuit of an amplifier.
13. An amplifier with $Z_i = 1K\Omega$ has a voltage gain $A=1000$. If a negative feedback of $\beta=0.001$ is applied to it. Calculate the input impedance of the feedback amplifier.
14. Compare LC and RC oscillators.
15. Draw the equivalent circuit of Transmission lines for low frequency.
16. Name any two voltage controlled power devices.
17. Write the syntax of "for loop" statement.
18. Write a note on Wi Fi.

PART- C

III. Answer any FIVE questions:

(5 x 3 = 15)

19. Derive the equation to determine the co-ordinates of Q-point in the voltage divider bias circuit.
20. Draw the frequency response of an amplifier with and without negative feedback.
21. Explain ionosphere in skywave propagation.
22. Derive an expression for modulation index in terms V_{maximum} and V_{minimum} .

23. A p-n junction diode has a reverse saturation current of 65 nA at 32°C. What should be the value of the forward current for a voltage drop of 0.5 V?
24. What are the advantages of static switches?
25. Draw the logic circuit of Half adder, write its truth-table and write the Boolean expression for outputs.
26. Draw the block diagram of satellite communication. Write one application.

PART- D

IV. Answer any THREE questions: (3 x 5 = 15)

27. Find the input resistance and voltage gain of the CE transistor amplifier for the data given below: $R_1=47\Omega$, $R_2=12K\Omega$, $R_c=3.3K\Omega$, $R_e=1K\Omega$, $R_l=10K\Omega$, $V_{cc}=18KV$, $\beta=100$, $V_{be}=0.3V$ and $r_e'=52mV/ I_e$.
28. Calculate the output voltage for the circuit shown below.

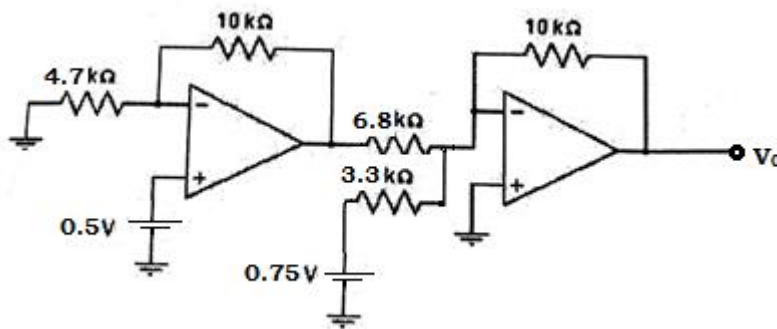

Type equation here.

29. Find the frequencies of LC tank circuits
 - a) $L=1\mu H$ $C=0.47\mu F$
 - b) $L=10mH$ $C=100pF$
30. A sinusoidal carrier Voltage $V_m=32\sin 2\pi \times 10^3$
31. Simplify the Boolean expression $Y=\sum m(0,1,4,13,15)+\sum d(2,5,7)$

PART- D

II. Answer any FOUR questions: (4 x 5 = 20)

28. Mention the types of transistor coupling amplifiers with block diagrams.
29. Obtain an expression for op-amp differentiator circuit.
30. What is need for modulation? Explain. Draw frequency spectrum of FM wave.
31. Explain the working of SISO shift register with relevant diagram.
32. Write the instructions to move 56H into register A, 4EH into register R0, then add them together. And save the result in register R1. What is the content of R1 after execution of the program?
33. Write a C program to accept the three integers and print the smallest amongst them.
