



IES MASTER

Institute for Engineers (IES/GATE/PSUs)

**ESE
2018**

Prelims Exam

**GENERAL STUDIES
& ENGINEERING APTITUDE**



**Detailed Solution
(SET-B)**

Office Address

DELHI: F-126, Katwaria Sarai, New Delhi - 110 016

Ph: 011-41013406, Mobile: 8130909220, 9711853908

NOIDA: B-23 A, 5th Floor, Gaurav Deep Heights, Near Fortis Hospital
Sector 62, Noida- 201305 **Ph:** 0120 415 1100



IES MASTER

Institute for Engineers (IES/GATE/PSUs)

Explanation of General Studies and Engg. Aptitude Prelims Paper-I (ESE - 2018)

SET - B

1. Consider the following statements with regard to atmospheric humidity :

1. Absolute humidity is the amount of water vapour per unit volume.
2. Hygrometer is used to measure relative humidity.
3. Dew point is the temperature at which the relative humidity is 75%

Which of the above statements are correct?

- (a) 1 and 2 only (b) 1 and 3 only
(c) 2 and 3 only (d) 1, 2 and 3

Ans. (a)

Sol. Absolute humidity is the measure of water vapor (moisture) in the air, regardless of temperature. It is expressed as grams of moisture per cubic meter of air (g/m³).

Hygrometer is an instrument that measures relative humidity.

The dew point is the temperature at which a given sample of air will have a relative humidity of 100 percent; hence, the saturation temperature.

2. Sanitary/municipal fills and waste heaps are unavoidably hazardous due to

1. Leachates
2. Emanating gases
3. Rodents and wandering animals
4. Automobile workshops that seem to have an affinity for such neighbourhoods

Which of the above are correct?

- (a) 1 and 4 only (b) 1 and 2 only
(c) 2 and 3 only (d) 3 and 4 only

Ans. (b)

Sol. Sanitary/municipal fills is the disposition of garbage by spreading in layers and covering with ashes or dirt to a depth sufficient to control rats, flies, and odors. They are hazardous because:

- (a) Leachates: They are the liquids that leach or leak from the landfill. Leakage of leachates contaminates the ground water.
- (b) Release of harmful gases: It emanates poisonous gases such as Methane and Sulphur di oxide which pollutes the air.
- (c) Presence of rodents and wandering animals are not the factors that make the Sanitary /municipal fills hazardous.
- (d) The effect of automobile workshops that seem to have an affinity for such neighbourhoods, have negligible effect on Sanitary /municipal fills due to least amount of pollution created by them.

Thus as per the options given in the question, (b) is the right answer.

3. Consider the following statements regarding depletion of the ozone layer :

1. Excessive release of chlorine and bromine in the environment from man-made compounds, such as chlorofluorocarbons.
2. Occurrence of certain natural phenomena such as sunspots, and stratospheric winds.
3. Degradation of materials by ultra-violets radiation.
4. Major volcanic eruptions.

Which of the above can be categorized as causing ozone depletion?

Office Address: F-126, Katwaria Sarai, New Delhi - 110 016
Telephone: 011-41013406, **Mobile:** 8130909220, 9711853908

Web: www.iesmaster.org

E-mail: info@iesmaster.org

SCROLL DOWN



IES MASTER

Institute for Engineers (IES/GATE/PSUs)

- (a) 1, 2 and 3 only (b) 1, 3 and 4 only
 (c) 1, 2 and 4 only (d) 2, 3 and 4 only

Ans. (c)

Sol. Causes of ozone depletion:

- (a) The chief ozone-depleting substances include chlorofluorocarbons (CFCs), carbon tetrachloride, hydrochlorofluoro carbons (HCFCs) and methyl chloroform. Halons, sometimes known as brominated fluorocarbons, also contribute mightily to ozone depletion.
- (b) Ozone Depleting Substances have been proven to be eco-friendly, very stable and non-toxic in the atmosphere below. This is why they have gained popularity over the years.
- When they float and remain static high up in the stratosphere, they are broken down by the strong UV light and the resultant chemical is chlorine and bromine. Chlorine and bromine are known to deplete the ozone layer at supersonic speeds. They do this by simply stripping off an atom from the ozone molecule. One chlorine molecule has the capability to break down thousands of ozone molecules.
- (c) Natural phenomena like sunspots and stratospheric winds also deplete ozone layer but to a lesser degree.

Note: Large volcanic eruptions can potentially inject significant quantities of chlorine (via hydrochloric acid - HCl) directly in the stratosphere where the highest concentrations of ozone are found. However, the vast majority of volcanic eruptions are too weak to reach the stratosphere, around 10 km above the surface. Thus, any HCl emitted in the eruption remains in the troposphere where it is quickly dissolved and washed out by rain. [Note that CFCs do not dissolve in

water and can therefore reach the stratosphere through atmospheric mixing.] In addition, there is no historical record that shows significant increases in chlorine in the stratosphere following even the most major eruptions.

4. Which one of the following is the major characteristic of deciduous trees?
- (a) They do not lose their leaves
 (b) They shed their leaves annually
 (c) They synthesize their own food
 (d) They depend on other factors for their food

Ans. (b)

Sol. The main characteristic of deciduous forests is that they seasonally shed leaves (annually in autumn).

5. A wall, rectangular in shape, has a perimeter of 72 m. If the length of its diagonal is 18m, what is the area of the wall?
- (a) 224m² (b) 486 m²
 (c) 572 m² (d) 606 m²

Ans. (b)

Sol.

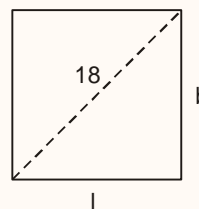

$$\text{ATQ, } l^2 + b^2 = 18^2 \quad \dots(1)$$

$$\text{Now, Perimeter} = 72$$

$$2l + 2b = 72$$

$$l + b = 36$$

$$l^2 + b^2 + 2lb = 1296$$

$$324 + 2lb = 1296$$

$$lb = 486$$

$$\text{Hence Area} = lb = 486$$

Office Address: F-126, Katwaria Sarai, New Delhi - 110 016
Telephone: 011-41013406, **Mobile:** 8130909220, 9711853908

Web: www.iesmaster.org

E-mail: info@iesmaster.org

SCROLL DOWN



IES MASTER

Institute for Engineers (IES/GATE/PSUs)

6. To isolate an enclosed area for conservation, an open traverse is run keeping close to (but outside of) the exterior boundary of the area through ground points $A \rightarrow B \rightarrow C \rightarrow D \rightarrow E \rightarrow F \rightarrow G \rightarrow$ towards H (to be eventually located). AB is 80° to the east of the north line at A. Deflection/Interior angles at B, C, D, E, F are indicated. What would be the magnitude of the deflection angle at G (as marked) so that GH may run parallel to BA? (Lengths are immaterial in this case).

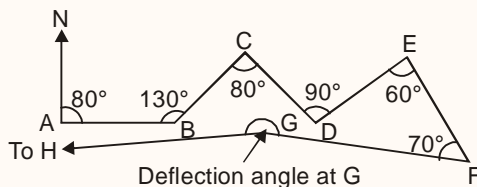

- (a) 190° (b) 210°
 (c) 200° (d) 230°

Ans. (a)

Sol.

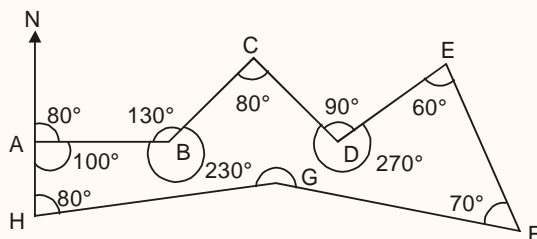

H and A are joined to make the open traverse a polygon of 8 sides ABCDEFGH

Sum of internal angles of polygon

$$= (2n - 4) \times 90 = (2 \times 8 - 4) \times 90$$

$$= 12 \times 90 = 1080^\circ$$

$$\Rightarrow \angle A + \angle B + \angle C + \angle D + \angle E + \angle F + \angle G + \angle H$$

$$= 180^\circ \text{ [All angles are interior angles]}$$

$$\Rightarrow 100 + 230 + 80 + 270 + 60 + 70 + \angle G + 80$$

$$= 1080$$

$$\Rightarrow \angle G = 190^\circ$$

7. Consider the following characteristics with respect to Alpha particles:

1. They have large specific ionization values
2. They dissipate their energy rather slowly
3. They can penetrate the outer layer of human skin
4. Their emitters are heavy elements

Which of the above statements are correct?

- (a) 1 and 4 only (b) 1 and 3 only
 (c) 2 and 4 only (d) 2 and 3 only

Ans. (a)

Sol.

Alpha particles are commonly emitted by all of the heavy radioactive nuclei occurring in the nature (uranium, thorium, radium). So, statement (4) is correct.

Alpha particles are heavily ionized matter and they quickly lose their kinetic energy. So, statement (2) is wrong but one is correct.

8. Increased biological oxygen demand is an indication of

1. Low microbial contamination
2. Absence of microbial pollution
3. High level of microbial contamination

Which of the above statements is/are correct?

- (a) 1 only (b) 2 only
 (c) 3 only (d) 1, 2 and 3

Ans. (c)

Sol.

Increased Biological Oxygen Demand indicates high level of microbial contamination. It means polluted water.

9. An association of two organisms of different species for mutual benefit, and where the individuals may not be able to survive separately, is called

- (a) Commensalism (b) Parasitic
 (c) Non-symbiotic (d) Symbiotic

Office Address: F-126, Katwaria Sarai, New Delhi - 110 016
 Telephone: 011-41013406, Mobile: 8130909220, 9711853908

Web: www.iesmaster.org

E-mail: info@iesmaster.org

SCROLL DOWN



IES MASTER

Institute for Engineers (IES/GATE/PSUs)

Ans (d)

Sol. Symbiosis describes close interactions between two or more different species. It is different from regular interactions between species, because in a symbiotic relationship, the two species in the relationship live together. Many organisms are involved in symbiotic relationships because this interaction provides benefits to both species. However, there are types of symbiosis that are not beneficial and may in fact harm one or both of the species.

Symbiotic relationships can be obligate or facultative. Obligate symbiosis is when two organisms are in a symbiotic relationship because they can't survive without each other. Facultative symbiosis is when the species live together by choice.

10. A simple project comprises of two start-to-end parallel paths, each with three activities in series, with no interpath dependencies. The a, m, b data (in days) for each activity are shown in the diagram. Assuming that three activities in series are enough for further computations, what will be the total project duration and its standard deviation?

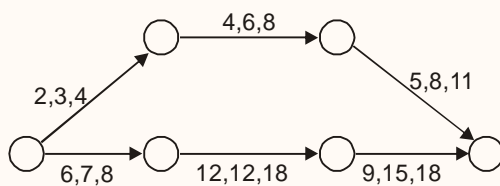

- (a) $35\frac{1}{2}$ days and $\frac{14}{3}$ days
- (b) $34\frac{1}{2}$ days and $\frac{5}{2}$ days
- (c) $35\frac{1}{2}$ days and $\frac{13}{6}$ days
- (d) $34\frac{1}{2}$ days and $\frac{11}{6}$ days

Ans. (d)

Sol.

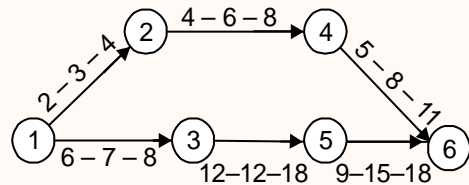

Calculation of Expected time (t_e)

$$t_e = \frac{a + 4m + b}{6}$$

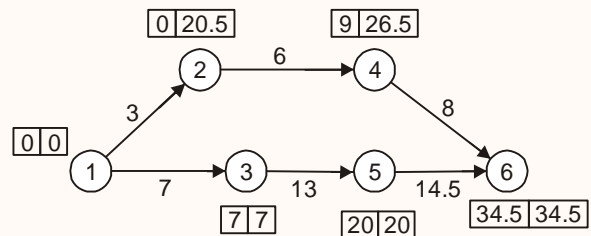

Project duration is 34.5

Standard deviation for whole project along critical will be

$$\sigma = \sqrt{\left(\frac{8-6}{6}\right)^2 + \left(\frac{18-12}{6}\right)^2 + \left(\frac{18-9}{6}\right)^2}$$

$$\sigma = \sqrt{\left(\frac{2}{6}\right)^2 + \left(\frac{6}{6}\right)^2 + \left(\frac{9}{6}\right)^2}$$

$$\sigma = \sqrt{\frac{4 + 36 + 81}{6^2}}$$

$$\sigma = \sqrt{\frac{121}{6^2}}$$

$$\sigma = \frac{11}{6}$$

11. Crashing is

- (a) Abandoning the project
- (b) Completing the project with all possible haste
- (c) Reduction of duration for a few of the activities
- (d) Reducing the cost of the project with all needful modifications

Office Address: F-126, Katwaria Sarai, New Delhi - 110 016
 Telephone: 011-41013406, Mobile: 8130909220, 9711853908

Web: www.iesmaster.org

E-mail: info@iesmaster.org

SCROLL DOWN



IES MASTER

Institute for Engineers (IES/GATE/PSUs)

Ans. (d)

Sol. Crashing is the process of obtaining minimum total project cost by reducing project duration along the critical path.

Hence it is reducing cost of the project with all needful modifications.

12. ABC analysis in materials management is a method of classifying the inventories based on the

- (a) Economic order quantity
- (b) Value of annual usage of the items
- (c) Volume of material consumption
- (d) Quantity of materials used

Ans. (b)

Sol. ABC analysis is based on annual usage value of the items. A category items have highest annual usage, B category items have medium usage and C category items have least usage.

13. CPM method of network analysis is

1. Ideally suited for linearly extending works
2. Meant essentially for research and development activities
3. Activity-oriented
4. Used for planning, scheduling and controlling purpose

Which of the above statements are correct?

- (a) 1 and 2 only
- (b) 2 and 3 only
- (c) 3 and 4 only
- (d) 1 and 4 only

Ans. (c)

Sol. CPM is activity oriented where as PERT is event oriented.

CPM is used for planning, scheduling and controlling of construction projects.

PERT is used for research and development project.

CPM can be used for any construction project which also involves linearly extending works.

14. The objective function $z = 3x_1 + 5x_2$ is to be maximized subject to constraints

$$x_1 + 2x_2 \leq 200$$

$$x_1 + x_2 \leq 150$$

$$x_1, x_2 \geq 0$$

The values of x_1 and x_2 in this context are, respectively

- (a) 100 and 75
- (b) 125 and 75
- (c) 100 and 50
- (d) 125 and 50

Ans. (c)

Sol. $z = 3x_1 + 5x_2$

Constraints are

$$x_1 + 2x_2 \leq 200 \Rightarrow x_1 + 2x_2 = 200$$

$$x_1 + x_2 \leq 150 \Rightarrow x_1 + x_2 = 150$$

$$x_1 = 100, x_2 = 50$$

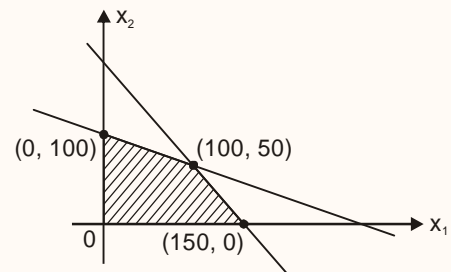

CP	Value of $z = 3x_1 + 5x_2$
(150, 0)	450
(0, 100)	500
(100, 50)	550 (maximum)

so $x_1 = 100$ and $x_2 = 50$

15. Consider the length of a room is 15m and width is 10m. If the sum of the areas of the floor and ceiling is equal to the sum of the areas of the four walls, then the volume of the room is

- (a) 900 m³
- (b) 1000 m³
- (c) 1200 m³
- (d) 1500 m³

Office Address: F-126, Katwaria Sarai, New Delhi - 110 016
Telephone: 011-41013406, **Mobile:** 8130909220, 9711853908

Web: www.iesmaster.org **E-mail:** info@iesmaster.org

SCROLL DOWN



IES MASTER

Institute for Engineers (IES/GATE/PSUs)

Ans. (a)

Sol. $l = 15, b = 10, h = ?$

ATQ,

$$2lxb = 2(lxh + bxh)$$

$$15 \times 10 = (15+10)h \Rightarrow h = 6$$

Now required volume = $l \times b \times h = 15 \times 10 \times 6 = 900m^3$

16. If the EOQ is 360 units, order cost is Rs. 5 per order and carrying cost is Rs 0.20 per unit, what is the usage?

- (a) 2654 units (b) 2592 units
(c) 1872 units (d) 1574 units

Ans. (b)

Sol. EOQ = 360

Ordering cost per order = Rs 5 per order

Carrying cost per unit = Rs 0.20

$$EOQ = \sqrt{\frac{2DC_o}{C_c}}$$

$$\Rightarrow 360 = \sqrt{\frac{2D \times 5}{0.20}}$$

$$\Rightarrow \frac{360^2 \times 0.20}{2 \times 5} = D$$

\Rightarrow Demand = 2592 units

17. If L_j = the latest occurrence time for event j, E_i = the earliest occurrence time for event i,

T_{ij} = the duration of activity \vec{ij} ,

What is the total float for activity \vec{ij} ?

- (a) $E_i - L_j - T_{ij}$ (b) $L_j - E_i - T_{ij}$
(c) $T_{ij} - E_i - L_j$ (d) $T_{ij} - L_j + E_i$

Ans. (b)

Sol. Total float is the maximum available time by which on activity can be delayed without affecting project completion time.

F_T = Maximum available time – Activity time

$$F_T = (L_j - E_i) - T_{ij}$$

$$F_T = L_j - E_i - T_{ij}$$

18. The process of removing irregular portions of stones and facilitating their easy transportation is known as

- (a) Quarrying (b) Reticulating
(c) Dressing (d) Pointing

Ans. (c)

Sol. The Dressing of stone is defined as "The process of giving a proper size, shape and finish to the roughly broken stones as obtained from the quarry."

This process is done manually or mechanically. A dressed stone is fit for use in particular situation in a building.

Moreover, the bulk of the stones being reduced by dressing, the cost of carriage is saved, without much danger of injuring the arrises in transit, as the stone is very hard.

For example: Granite is quarried either by wedging or by blasting. The former process is generally reserved for large blocks, and the latter for smaller pieces and road-metal.

19. On which of the following factors does hysteresis loss depend?

1. Magnetic field intensity
 2. Frequency of the field
 3. Volume of material
 4. Neel temperature
- (a) 1, 2 and 4 only (b) 1, 3 and 4 only
(c) 2, 3 and 4 only (d) 1, 2 and 3 only

Ans. (d)

Sol. Hysteresis loss = $\eta B_{max}^{1.6} f \times V$

B = Magnetic field

Office Address: F-126, Katwaria Sarai, New Delhi - 110 016
Telephone: 011-41013406, **Mobile:** 8130909220, 9711853908

Web: www.iesmaster.org

E-mail: info@iesmaster.org

SCROLL DOWN



IES MASTER

Institute for Engineers (IES/GATE/PSUs)

f = Frequency of the field

V = Volume of material

So, (d) is correct.

20. What is the volume of an FCC unit cell in terms of its atomic radius R ?

(a) $\sqrt{3} R^3$ (b) $16 R^3 \sqrt{2}$

(c) $16 R^3 \sqrt{3}$ (d) $\sqrt{2} R^3$

Ans. (b)

Sol. For FCC

$$R = \frac{a}{2\sqrt{2}}$$

$$\Rightarrow a = 2\sqrt{2} R$$

$$\therefore \text{Volume} = a^3 = (2\sqrt{2}R)^3 = 16\sqrt{2} R^3$$

Directions: Each of the next twenty (20) items consists of two statements, one labelled as 'Statement (I)' and the other as 'Statement (II)'. Examine these two statements carefully and select the answers to these items using the codes given below:

Codes:

- (a) Both Statement (I) and Statement (II) are individually true and Statement (II) is the correct explanation of Statement (I).
- (b) Both Statement (I) and Statement (II) are individually true, but Statement (II) is **not** the correct explanation of Statement (I).
- (c) Statement (I) is true, but Statement (II) is false.
- (d) Statement (I) is false, but Statement (II) is true.

21. **Statement (I)** : Atoms can neither be created nor destroyed.

Statement (II) : Under similar conditions of temperature and pressure, equal volumes of gases do not contain an equal number of atoms.

Ans. (b)

Sol. Atoms are the basic entity of any elements which can neither be created nor destroyed.

Avogadro's law states that, "equal volumes of all gases, at the same temperature and pressure, have the same number of molecules". However it is not true in case of atoms, for mono atomic diatomic and triatomic gases it will get differed.

Here individually both the statements are correct but one does not follows another.

22. **Statement (I)** : Lifts and external staircases are provided with access from the lobby area of each floor in multistorey blocks. The external staircase must be accessible through self-closing, 180°-swing unlocked doors (with provision for locking at appropriate conditions).

Statement (II) : Such staircases should not be inadvertently subjected to spreading of smoke, but must yet provide unhindered exit from the lobby of each floor.

Ans. (b)

Sol. The external staircase provided in a multistory building is generally used for fire escape, hence it should be assessable through self closing, 180 degree swing unlock doors. Also, it should not be subjected to spreading of smoke.

23. **Statement (I)** : Volcanic eruption is often accompanied by earthquakes.

Statement (II) : Volcanoes erupt dust particles in the atmosphere.

Ans. (b)

Sol. Volcanoes are often found in areas of crustal weakness and the mass of the volcano its self adds to the regional strain. Most earthquakes occur in response to regional strain exerted in an area of weak faults that are caused by volcanic eruptions.

Office Address: F-126, Katwaria Sarai, New Delhi - 110 016
Telephone: 011-41013406, **Mobile:** 8130909220, 9711853908

Web: www.iesmaster.org

E-mail: info@iesmaster.org

SCROLL DOWN



IES MASTER

Institute for Engineers (IES/GATE/PSUs)

They can also be generated from changes of pressure under the volcano caused by the injection or removal of magma (molten rock) from the volcanic system. After the withdrawal of magma from a system, an empty space is left to be filled. The result is a collapse of surrounding rock to fill the void, also creating earthquakes.

Volcanoes do emit dust particles and magma in the atmosphere during eruption.

Thus, both the statements are correct but statement 2 is not the correct explanation of statement 1.

- 24. Statement (I) :** Quality is essential for survival and growth of an organisation in the present era of tough competition.

Statement (II) : The concept of quality is confined only to construction and manufacturing organisations.

Ans. (c)

- Sol.** Quality is essential because of the tough competition in the era of globalisation and information technology. The companies have to compete with both domestic as well as foreign companies.

The concept of quality is not confined to construction and manufacturing sector only but it extends to all other sectors including service sector.

- 25. Statement (I) :** The concept of Just-In-Time is operationalized when the exact number of units required are bought at each successive stage of production, at the appropriate time.

Statement (II) : Just-In-Time concept has been expanded to mean a manufacturing philosophy of eliminating waste.

Ans. (b)

- Sol.** Just-In-Time is possible when the exact demand is known. Thus it minimises the need for inventory and eliminates waste.

JIT is also linked with lean manufacturing, thus minimising the consumption of resources and eliminating waste.

- 26. Statement (I) :** Total Productive Maintenance (TPM) is productive maintenance involving total participation as a group activity.

Statement (II) : Under the aegis of TPM, individual operators generally take care of minor maintenance aspects.

Ans. (b)

- Sol.** TPM involves all the departments and all the employees of the organisation from top to bottom.

In TPM, operators working at the equipment are trained and given a sense of ownership and hence they generally take care of minor maintenance aspects.

- 27. Statement (I) :** Green energy refers to one which does not harm the ecosystem of planet Earth.

Statement (II) : All renewable energy is green energy.

Ans. (b)

- Sol.** Green energy comes from natural sources such as sunlight, wind, rain, tides, plants, algae and geothermal heat. Types of green energy are Solar Power, Wind Power, Hydropower, Geothermal Energy, Biomass and Biofuels. They don't harm the planet Earth.

Types of Renewable energy are:

1. Wind power
2. Hydropower
3. Solar energy
4. Geothermal energy
5. Bio energy

Therefore, it is concluded that all renewable energy is green energy.

Office Address: F-126, Katwaria Sarai, New Delhi - 110 016
Telephone: 011-41013406, **Mobile:** 8130909220, 9711853908

Web: www.iesmaster.org

E-mail: info@iesmaster.org

SCROLL DOWN



IES MASTER

Institute for Engineers (IES/GATE/PSUs)

Thus both the statements are correct. But, statement 2 doesn't correctly explain the existence of statement 1.

- 28. Statement (I) :** To practise terraced cultivation in hill slopes, it can be admissible to have the vertical face of the terraced boundary run perpendicular to the ground trace of the fault line, if any, in the underlying land.

Statement (II) : Fault lines are susceptible to slips and should be guarded against in land use.

Ans. (a)

- Sol.** Fault lines are susceptible to slips and should be guarded against in land use therefore, in terrace cultivation, to avoid slipping condition the terrace boundary are generally preferred perpendicular to the ground trace of the fault line.

- 29. Statement (I) :** Normally carbon dioxide is not considered an air pollutant.

Statement (II) : Carbon dioxide is a constituent of atmospheric air.

Ans. (b)

- Sol.** Major air pollutants are: Carbon monoxide, Lead, Nitrogen dioxide, Ozone, Particles and Sulfur dioxide. Carbon dioxide is not a pollutant. Carbon dioxide is not harmful to ordinary things, to human beings, or to animals, or to plants. It's actually needed for plant growth.

By volume, atmospheric air contains 78.09% nitrogen, 20.95% oxygen, 0.93% argon, 0.04% carbon dioxide, and small amounts of other gases. Thus, it is part of atmospheric air.

- 30. Statement (I) :** The size of a hydrogen balloon increases as it rises in the air.

Statement (II) : The material of the balloon can be easily stretched.

Ans. (b)

- Sol.** The size of hydrogen balloon increases as it rises in the air because the pressure of air keeps on decreasing.

The material of the balloon is easily stretched.

- 31. Statement (I) :** Preparation of bar charts is merely a scheduling operation while the preparation and analysis of a network is a planning function.

Statement (II) : A bar chart, prima facie, does not show the interrelationships between activities.

Ans. (b)

- Sol.** Bar chart is simply used for scheduling of projects.

Project planning involves preparation and analysis of network diagram i.e. project scheduling.

Biggest drawback of bar chart is that they do not show inter relationship between activities.

- 32. Statement (I) :** Project management is essentially the process to plan its implementation and to pre-determine the period-wise need of resources including funds and personnel, given the choice of total duration and quality standards.

Statement (II) : Of the four dimensions (not denying that there can be some more) of a project, viz., scope, cost, time and quality, only any two can be pre-assigned; others have to abide by these two prescriptions.

Ans. (c)

- Sol.** It is not necessary that out of scope, cost, time and quality, only two can be pre-assigned and then others have to abide by these two prescriptions.

Example : Scope, time and quality can be pre-assigned, thereafter cost can be determined.

Office Address: F-126, Katwaria Sarai, New Delhi - 110 016
Telephone: 011-41013406, **Mobile:** 8130909220, 9711853908

Web: www.iesmaster.org

E-mail: info@iesmaster.org

SCROLL DOWN



IES MASTER

Institute for Engineers (IES/GATE/PSUs)

33. Statement (I) : High strength, super-duralumin alloys are adopted in the manufacture of aero engines.

Statement (II) : Precipitation heat treatment is adopted for duralumin products.

Ans. (b)

Sol. High strength super-duralumin's alloys are used to manufacture aero engine because of strength and density.

It's density is $1/3^{\text{rd}}$ of steel so, it is used in aeroplane.

By precipitation hardening, strength of non-ferrous alloy is increased, e.g. Aluminium alloy, Magnesium alloy, Copper alloy etc.

So, both statement is true.

34. Statement (I) : Metal carbides and carbon are used as refractories as they resist oxidation.

Statement (II) : Metal carbides and carbon are not particularly suitable for high temperature applications.

Ans. (c)

Sol. Metal carbides are interstitial e.g. Tungsten carbide etc. Which are thermally stable at high temperature (e.g. 1500° , 1600° , 2000°).

Metal or metalloid atoms from carbide can selectively be extracted at high temperature (usually above 1200°C) under vacuum.

The underlying mechanism is in congruent decomposition of carbides using the high melting point of carbon compared to corresponding carbide metal that melt away leaving the carbon behind.

Also, alloys rich in carbide phases have much lower oxidation rates. Than alloys containing solid solution phases.

35. Statement (I) : Long chain polymers are weaker than most ceramics and metals.

Statement (II) : The molecular chains in long chain polymers are bonded to each other with Van der Waals bonds.

Ans. (a)

Sol. In linear long chain polymer there are extensive vander waals bonding between chain which is secondary bond because of which these are weaker. Here secondary bond govern the properties of material not primary.

In ceramic and metal in general primary bond exist. In between that molecules so, these are comparatively stronger.

36. Statement (I) : Mechanically, pearlite has properties intermediate between the soft ductile ferrite and the hard brittle cementite.

Statement (II) : Alpha iron can be made magnetic above 768°C .

Ans. (c)

Sol. Pearlite is a mixture of 87.5% ferrite and 12.5% cementite as ferrite is soft and ductile so, pearlite is soft but less than ferite cemetite is hard and brittle so, based on it's percentage in pearlite, pearlite is less hard brittle in comparison to cementite. 768°C is currie temperature below hcih iron is magnetic.

37. Statement (I) : Information and communication technologies can play a key role in the development and economic growth of rural India.

Statement (II) : Successful ICT application in e-governance giving respective one-stop solutions for rural communities is an absolute need of the hour.

Ans. (a)

Sol. Information and Communication Technologies (ICTs) play a key role in development & Economic growth of the Developing countries of the World. Major part of developing countries comprises of rural areas

Combining ICT in Rural Development can not only speed up the development process but it can also fill the gaps between the educationally and technologically backward and forward sections of the society.

Office Address: F-126, Katwaria Sarai, New Delhi - 110 016
Telephone: 011-41013406, **Mobile:** 8130909220, 9711853908

Web: www.iesmaster.org

E-mail: info@iesmaster.org

SCROLL DOWN



IES MASTER

Institute for Engineers (IES/GATE/PSUs)

Sol.

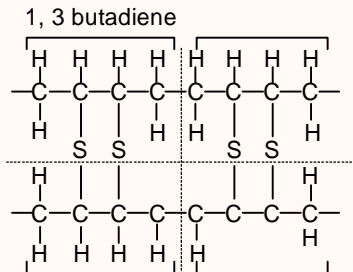

Cross linked butadiene rubber

For two monomer unit of 1, 3 butadiene, molecular weight

$$\equiv 8 * \frac{12 \text{ gm}}{\text{mol}} + 12 * \frac{1 \text{ gm}}{\text{mol}} = 108$$

For two monomer unit two sulphur atoms are taken to form cross linking.

∴ Atomic weight of sulphur = 32 gm/mol.

∴ 2 sulphur atoms are used

Fraction of sulphur used

$$= \frac{2 * 32 \text{ gm/mol}}{2 * 32 \text{ gm/mol} + 108 \text{ gm/mol}}$$

$$= \frac{64}{64 + 108} = 0.37$$

∴ For 100 kg, 37 kg of sulphur is used.

42. Which one of the following is termed as sacrificial protection of metal?

- (a) Galvanization (b) Tinning
(c) Organic coating (d) Inorganic coating

Ans. (a)

Sol. A sacrificial protection is the protection of iron or steel against corrosion by using more reactive metal. Here, protected metal becomes the cathode and does not corrode. The process is termed as galvanizing.

43. The material used in the production of bearings is

- (a) Cast iron (b) Babbitt metal
(c) Pig iron (d) Steel

Ans. (b)

Sol. Babbitt metals used for bearing material due to their excellent embeddability properties.

44. Malleable cast iron is produced

1. By quick cooling of cast iron.
2. By adding magnesium to molten cast iron.
3. From white cast iron by annealing.

Which of the above statements is/are correct?

- (a) 1 only (b) 2 only
(c) 3 only (d) 1, 2 and 3

Ans. (c)

Sol. When white cast iron is heated to a temperature of 800–900°C for a prolonged period and in neutral atmosphere, then malleable cast iron formed.

45. The critical temperature above which ferromagnetic materials lose their magnetic property is called.

- (a) Kelvin point
(b) Curie point
(c) Recrystallization point
(d) Celsius point

Ans. (b)

Sol. Above curie point, ferromagnetic materials converts into paramagnetic material.

46. The Hall Effect may be used to

1. Determine whether the semiconductor is p-type or n-type.
2. Determine the carrier concentration.
3. Calculate the mobility.

Which of the above statements are correct?

- (a) 1 and 2 only (b) 1 and 3 only
(c) 2 and 3 only (d) 1, 2 and 3

Ans. (d)

Office Address: F-126, Katwaria Sarai, New Delhi - 110 016
Telephone: 011-41013406, **Mobile:** 8130909220, 9711853908

Web: www.iesmaster.org

E-mail: info@iesmaster.org

SCROLL DOWN



IES MASTER

Institute for Engineers (IES/GATE/PSUs)

Sol. Hall effect is used to

- (i) Find p-type (or) n-type
- (ii) Mobility
- (iii) Carrier concentration

47. Which of the following sets of free software tools are suitable for ICT-based education as well as an open source?

- (a) Scilab, Osdag, PHP and Latex
- (b) Java, LibreOffice, Audacity and Matlab
- (c) Scilab, Arduino, LibreOffice and Latex
- (d) Scilab Octave, Netduino and Latex

Ans. (a)

Sol. All the given four tools are used as educational tools in ICT.

Scilab : Scilab is free and open source software for numerical computation providing a powerful computing environment for engineering and scientific applications.

Osdag : The development of Osdag is currently funded by the Ministry of Human Resource Development (MHRD), Govt. of India, through the FOSSEE project under the National Mission on Education (NME) through ICT.

PHP : PHP is a scripting language designed for web development.

Latex : Springer has developed LaTeX style files and Word templates to prepare lecture, notes etc..

48. Which of the following are the benefits of e-governance system?

- 1. Simplicity, efficiency and accountability
 - 2. Quality service to citizens
 - 3. Better access to information
 - 4. Expanded reach of governance
- (a) 1, 2 and 3 only (b) 1, 2 and 4 only
(c) 3 and 4 only (d) 1, 2, 3 and 4

Ans. (d)

Sol. i. Simplicity, efficiency and accountability : Application of ICT to governance combined with detailed business process reengineering would lead to simplification of complicated processes, weeding out of redundant processes, simplification in structures and changes in statutes and regulations. The end result would be simplification of the functioning of government, enhanced decision making abilities and increased efficiency across government - all contributing to an overall environment of a more accountable government machinery. This, in turn, would result in enhanced productivity and efficiency in all sectors.

ii. Better access to information and quality services for citizens: ICT would make available timely and reliable information on various aspects of governance. In the initial phase, information would be made available with respect to simple aspects of governance such as forms, laws, rules, procedures etc later extending to detailed information including reports (including performance reports), public database, decision making processes etc. As regards services, there would be an immediate impact in terms of savings in time, effort and money, resulting from online and one-point accessibility of public services backed up by automation of back end processes. The ultimate objective of e-Governance is to reach out to citizens by adopting a life-cycle approach i.e. providing public services to citizens which would be required right from birth to death.

iii. Expanded reach of governance: Rapid growth of communications technology and its adoption in governance would help in bringing government machinery to the doorsteps of the citizens. Expansion of telephone network, rapid strides in mobile

Office Address: F-126, Katwaria Sarai, New Delhi - 110 016
Telephone: 011-41013406, **Mobile:** 8130909220, 9711853908

Web: www.iesmaster.org

E-mail: info@iesmaster.org

SCROLL DOWN



IES MASTER

Institute for Engineers (IES/GATE/PSUs)

telephony, spread of internet and strengthening of other communications infrastructure would facilitate delivery of a large number of services provided by the government. This enhancement of the reach of government - both spatial and demographic - would also enable better participation of citizens in the process of governance.

49. What does CDMA stand for?
- Code Division Mobile Access
 - Code Division Multiple Access
 - Code Division Multiple Applications
 - Code Division Mobile Applications.

Ans. (b)

Sol. CDMA, which stands for Code Division Multiple Access, is a competing cell phone service technology to GSM, the world's most widely used cell phone standard.

The CDMA standard was originally designed by Qualcomm in the U.S. and is primarily used in the U.S. and portions of Asia by other carriers.

50. A small production unit now works 6 days per week with 3 ½ hours of first shift every one of the 6 days and 3 hours of second shift for each of the first 5 days. Wage negotiations led to an agreement to work on 5 days a week with both shifts together clocking 7 ½ hours per day with an 8% increase in weekly wages. How much change in the hourly production would mean parity in the agreement for both management and employees?

- 3.68%
- 2.15%
- 1.82%
- 1.33%

Ans. (a)

Sol. Earlier they are working = $6 \times 3.5 \text{ hrs} + 5 \times 3 = 36 \text{ hrs}$

Let hourly wages is of 1 Rs then total money they were getting = $36 \times 1 = 36 \text{ Rs.}$

Now for new policy salary increment is of 8%

So now they are getting = $36 \times 1.08 = 38.88 \text{ Rs}$

and for new policy they have to work = $7.5 \times = 37.5 \text{ hrs.}$

Now as per old policy management has to pay $37.5 \times 1 = 37.5 \text{ Rs.}$

But as per new policy management payingn = 38.88 Rs.

So to avoid this discrepancy, % change in hourly payment

$$= \left(\frac{38.88 - 37.5}{37.5} \right) \times 100 = 3.68\%$$

51. Consider the following statements :

- National Agricultural Portal, eNAM, is designed to create a unified national market for agricultural commodities.
- Farmers can showcase their produce online from the nearest market and the buyer can quote his price from anywhere.

Which of the above statements is/are correct?

- 1 only
- 2 only
- Both 1 and 2
- Neither 1 nor 2

Ans. (c)

Sol. National Agriculture Market (NAM) is a pan-India electronic trading portal which networks the existing APMC mandis to create a unified national market for agricultural commodities.

It provides access to a nationwide market for the farmer, with prices commensurate with quality of his produce and online payment and availability of better quality produce and at more reasonable prices to the consumer.

52. Consider the following statements regarding the code of ethics for Engineers:

Office Address: F-126, Katwaria Sarai, New Delhi - 110 016
Telephone: 011-41013406, **Mobile:** 8130909220, 9711853908
Web: www.iesmaster.org **E-mail:** info@iesmaster.org

SCROLL DOWN



IES MASTER

Institute for Engineers (IES/GATE/PSUs)

1. The safety, health and welfare of the public are of paramount importance
2. Perform services only in the area of their competence.
3. Issue public statements strictly in an objective and truthful manner.
4. Avoid deceptive acts.

Which of the above statements are correct?

- (a) 1, 2 and 3 only (b) 1, 2 and 4 only
(c) 3 and 4 only (d) 1, 2, 3 and 4

Ans. (d)

Sol. Code of Ethics for Engineer includes all 4 points.

Hence, the answer is (d).

53. In a radar system, the term 'Rat-Race' is used in connection with

- (a) Modulator
(b) Pulse characteristics
(c) Receiver bandwidth
(d) Duplexer

Ans. (b)

Sol. Rat race also known as hybrid-ring-junction. It is used in connection with Pulse Characteristics.

54. Consider the following statements:

1. Material science deals with the strength and stiffness behaviour of components (buildings/machines/vehicle facilities) based on their response to imposed stresses (forces, moments, torque, etc.)
2. Material properties are dependent on their micro-structure and response to force fields and surface interaction

Which of the above statement is/are correct?

- (a) 1 only (b) 2 only
(c) Both 1 and 2 (d) Neither 1 nor 2

Ans. (c)

Sol. Statement 1 is related to testing of material so, it is correct.

In statement 2 material properties depends on grain and grain boundaries i.e. microstructure.

Material properties are also influenced by type of grain. Fine grain, Coarse grain, interstitial space, defect etc. Hence it is also correct.

55. PQLI is based on

- (a) Infant mortality, life expectancy and adult literacy rate
(b) Crime rate, clean environment and quality of housing
(c) Air pollution, water pollution and sanitation conditions
(d) Health, education and environment

Ans. (a)

Sol. PQLI

The Physical Quality of Life Index (PQLI) is an attempt to measure the quality of life or well-being of a country. It is based on three indicators: basic literacy rate, infant mortality, and life expectancy.

56. HDI is a better index of development because

- (a) GDP growth may not consider personal growth situation
(b) It takes into consideration reduction of poverty
(c) It covers income, health and education aspects of development
(d) It covers promotion of growth

Ans. (c)

Sol. HDI measures a country's overall achievement in its social and economic dimensions. HDI is a better index of development because it measures average achievement in three basic dimensions of human development—a long and healthy life, knowledge and a decent standard of living.

Office Address: F-126, Katwaria Sarai, New Delhi - 110 016
Telephone: 011-41013406, **Mobile:** 8130909220, 9711853908

Web: www.iesmaster.org

E-mail: info@iesmaster.org

SCROLL DOWN



IES MASTER

Institute for Engineers (IES/GATE/PSUs)

57. IPR protects the use of information and ideas that are of
- (a) Ethical value (b) Moral value
(c) Social value (d) Commercial value

Ans. (d)

Sol. Regarding IPR, Intellectual property (IP) refers to the creations of the mind, such as inventions; literary and artistic works; designs; and symbols, names and images used in commerce. Hence, the answer is (d), Commercial Value.

58. A Whistleblower is someone who
- (a) Whistles classical music
(b) Informs on any illegal, unethical or corrupt activity going on in the organisation
(c) Is adept in whistling
(d) Boasts about himself/herself

Ans. (b)

Sol. Regarding Whistleblower

A whistleblower is a person who exposes any kind of information or activity that is deemed illegal, unethical, or not correct within an organization. Hence, the answer is (b).

59. What is meant by 'Conflict of interest'?
- (a) Being interested in many subjects
(b) Hobbies interfering in education
(c) Least interest in the job taken up or assigned
(d) A conflict between the private interests and the official responsibilities of a person in a position of trust

Ans. (d)

Sol. Regarding Conflict of Interest :

Conflict of interest is conflict between private interest and public interest (official responsibility). Hence, the answer is (d).

60. What is 'Nepotism'?
- (a) Undermining the morale of workers
(b) Harassment of women workers
(c) Being autocratic in decision-making
(d) Hiring friends or relatives and showing favouritism in work

Ans. (d)

Sol. Regarding Nepotism

Nepotism is the practice among those with power or influence of favouring relatives or friends, especially by giving them jobs. Hence, the answer is (d).

61. What is the value of $(1525)^{0.2}$ to 2 decimal places?
- (a) 4.33 (b) 4.36
(c) 4.38 (d) 4.30

Ans. (a)

Sol. $(1525)^{0.2} = (1525)^{1/5} = ?$

$$\text{Consider } \boxed{f(x) = x^5 - 1525 \text{ \& } f'(x) = 5x^4}$$

Let initial assumption $x_0 = 4.0$

So by Newton Rapshon method

$$\text{Iteration 1 : } x_1 = x_0 - \frac{f(x_0)}{f'(x_0)} = 4 - \frac{f(4)}{f'(4)}$$

$$= 4.0 - \left(\frac{4^5 - 1525}{5 \cdot 4^4} \right) = 4 + \frac{501}{1280} = 4.39$$

$$\text{Iteration 2 : } x_2 = 4.39 - \frac{105.50}{1857.06} = 4.33$$

$$\text{Iteration 3 : } x_3 = 4.33 + \frac{2.91}{1757.60} = 4.33$$

Hence 5th root of 1525 = 4.33

62. In the Laurent expansion of

$$f(z) = \frac{1}{(z-1)(z-2)} \text{ valid in the region } 1 < |z| < 2, \text{ the coefficient of } \frac{1}{z^2} \text{ is}$$

Office Address: F-126, Katwaria Sarai, New Delhi - 110 016
Telephone: 011-41013406, **Mobile:** 8130909220, 9711853908

Web: www.iesmaster.org

E-mail: info@iesmaster.org

SCROLL DOWN



IES MASTER

Institute for Engineers (IES/GATE/PSUs)

- (a) 0 (b) $\frac{1}{2}$
 (c) 1 (d) -1

Ans. (d)

Sol. $f(z) = \frac{1}{(z-1)(z-2)} = \frac{1}{z-2} - \frac{1}{z-1}$

$$= -\frac{1}{2} \left(\frac{1}{1-\frac{z}{2}} \right) - \frac{1}{z} \left(\frac{1}{1-\frac{1}{z}} \right) \quad (\because 1 < |z| < 2)$$

$$= -\frac{1}{z} \left[1 - \frac{z}{2} \right]^{-1} - \left[1 - \frac{1}{z} \right]^{-1}$$

$$= -\frac{1}{z} \left[1 + \frac{z}{2} + \frac{z^2}{4} + \frac{z^3}{8} + \dots \right]$$

$$- \frac{1}{z} \left[1 + \frac{1}{z} + \frac{1}{z^2} + \frac{1}{z^3} + \dots \right]$$

$$= \left(-\frac{1}{2} - \frac{z}{4} - \frac{z^2}{8} - \frac{z^3}{16} - \dots \right) - \frac{1}{z} - \frac{1}{z^2} - \frac{1}{z^3} - \dots$$

So coefficient of $\left(\frac{1}{z^2} \right)$ is -1

63. If $u = \log \left(\frac{x^2 + y^2}{x + y} \right)$, what is the value of

$$x \frac{\partial u}{\partial x} + y \frac{\partial u}{\partial y} ?$$

- (a) 0 (b) 1
 (c) u (d) eu

Ans. (b)

Sol. $u = \log_e \left(\frac{x^2 + y^2}{x + y} \right)$

Let $v = e^u = \frac{x^2 + y^2}{x + y}$

$\therefore V(\lambda x, \lambda y) = \lambda V(x, y)$ so v is homogenous function

so by Euler's theorem

$$x \frac{\partial v}{\partial x} + y \frac{\partial v}{\partial y} = nv$$

$$x \frac{\partial (e^u)}{\partial x} + y \frac{\partial (e^u)}{\partial y} = 1 \cdot e^u$$

$$x \frac{\partial u}{\partial x} + y \frac{\partial u}{\partial y} = 1$$

64. What is the residue of the function $\frac{1 - e^{2z}}{z^4}$ at its pole?

- (a) $\frac{4}{3}$ (b) $-\frac{4}{3}$
 (c) $-\frac{2}{3}$ (d) $\frac{2}{3}$

Ans. (b)

Sol. $f(z) = \frac{1 - e^{2z}}{z^4}$

$$= \frac{1 - \left(1 + 2z + \frac{(2z)^2}{2} + \frac{(2z)^3}{6} + \frac{(2z)^4}{24} + \dots \right)}{z^4}$$

$$= -2 \left(\frac{1}{z^3} \right) - 2 \left(\frac{1}{z^2} \right) - \frac{4}{3} \left(\frac{1}{z} \right) - \frac{2}{3} - \frac{32}{120} (z) + \dots$$

Which is Laurent expansion of f(z) about z = 0 and it is pole of order 3.

So residual of f(z) at (z = 0) = coefficient of

$$\left(\frac{1}{z} \right) = -\frac{4}{3}$$

65. What is the maximum value of z, if $z = 10x + 6y$ subject to the constraints

$$3x + y \leq 12, 2x + 5y \leq 34, x \geq 0, y \geq 0 ?$$

- (a) 56 (b) 52
 (c) 50 (d) 40

Ans. (a)

Office Address: F-126, Katwaria Sarai, New Delhi - 110 016
Telephone: 011-41013406, **Mobile:** 8130909220, 9711853908

Web: www.iesmaster.org

E-mail: info@iesmaster.org

SCROLL DOWN



IES MASTER

Institute for Engineers (IES/GATE/PSUs)

Sol. $z = 10x + 6y$, and constraints are

$$\begin{aligned} 3x + 2y &\leq 12 &\Rightarrow 3x + 2y &= 12 \\ 3x + 5y &\leq 34 &\Rightarrow 2x + 5y &= 34 \end{aligned}$$

On solving, $x = 2, y = 6$

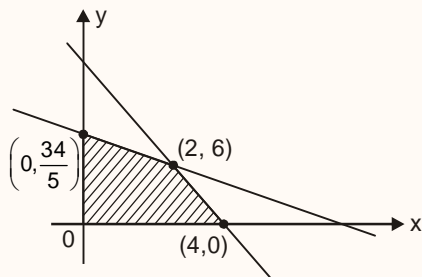

Critical points are $(4, 0)$, $(0, \frac{34}{5})$, $(2, 6)$ and

$$z = 10x + 6y$$

$$\text{so at } (4, 0) ; z = 40$$

$$\text{at } (0, \frac{34}{5}) ; z = 40.8$$

$$\text{at } (2, 6) ; z = 56 \text{ (maximum)}$$

66. Which of the following concepts are relatable to income of members of the public while considering public welfare?

1. Sensitivity of demand
 2. Elasticity of demand
 3. Sensitivity of expenditure
 4. Elasticity of expenditure
- (a) 1 and 2 only (b) 2 and 3 only
(c) 3 and 4 only (d) 1 and 4 only

Ans. (a)

Sol.

67. Consider the following provisions regarding safety on highways, where major improvement works may also be in progress :

1. Highly visible barricades to avoid falling of vehicles in deep interspaces ahead (including drainages)

2. Wire-net provisions to ward off road slippages
3. Signages for wild-animals crossing (like deer, elephant etc.)
4. Signages on minor gradients

Which of the above are relevant ?

- (a) 1, 2, 3 and 4 (b) 1, 2 and 4 only
(c) 1, 3 and 4 only (d) 1, 2 and 3 only

Ans. (d)

Sol. For highway safety minor gradient throughout the project is required to improve the drainage system. But signage on minor gradient is not required. Hence, option d is correct

68. A vehicle moving at a speed of 88 km/hr weighs 62293.5 N and its rolling resistance coefficient is 0.018. The rolling resistance of the vehicle is

- (a) 1121.3 N (b) 1000.4 N
(c) 975.7 N (d) 845.6 N

Ans. (a)

Sol. Rolling Resistance = Rolling resistance coefficient \times Weight of vehicle

$$= 0.018 \times 62293.5$$

$$= 1121.283 \text{ N}$$

$$\cong 1121.3 \text{ N}$$

69. For a vehicle travelling at 24 km/hr having a wheel radius of 0.305 m with overall gear ratio $G = 19.915$, and when torque transmitted is 203.6 N.m, the engine speed and power are, nearly.

- (a) 4155 rpm and 88.6 kW
(b) 4500 rpm and 88.6 kW
(c) 4155 rpm and 95.4 kW
(d) 4500 rpm and 95.4 kW

Ans. (a)

Office Address: F-126, Katwaria Sarai, New Delhi - 110 016
Telephone: 011-41013406, **Mobile:** 8130909220, 9711853908

Web: www.iesmaster.org

E-mail: info@iesmaster.org

SCROLL DOWN



IES MASTER

Institute for Engineers (IES/GATE/PSUs)

Sol. Wheel rotation velocity in rpm

$$= \frac{\text{Vehicle Velocity}}{\text{Circumference of wheel}}$$

$$= \frac{24 \times 1000}{2 \times \pi \times 0.305} = 208.7 \text{ rpm}$$

Engine rotational velocity

$$= \text{Overall gear ratio} \times \text{wheel rotational velocity (rpm)}$$

$$= 19.915 \times \text{wheel rpm}$$

So, engine rotational velocity (rpm)

$$= 19.915 \times 208.7$$

$$= 4156.8 \text{ rpm}$$

Engine power = Torque \times Angular displacement

$$= \frac{203.6 \times 4156.8 \times 2\pi}{60}$$

$$= 88.6 \text{ kW}$$

70. A rod of length L , cross-section area A_1 and modulus of elasticity E_1 , has been placed inside a tube of length L , of cross-section area A_2 and modulus of elasticity E_2 , and the two are firmly held by end plates. The portion of the load P applied on the end plates shared by rod and tube, respectively, are

(a) $\frac{PA_1E_1}{A_1E_1 + A_2E_2}$ and $\frac{PA_2E_2}{A_1E_1 + A_2E_2}$

(b) $\frac{PA_2E_2}{A_1E_1 + A_2E_2}$ and $\frac{PA_1E_1}{A_1E_1 + A_2E_2}$

(c) $\frac{PA_1E_1}{A_1E_1 + A_2E_2}$ and $\frac{PA_2E_2}{A_1E_2 + A_2E_2}$

(d) $\frac{PA_1E_1}{A_1 + A_2}$ and $\frac{PA_2E_2}{A_1 + A_2}$

Ans. (a)

Sol.

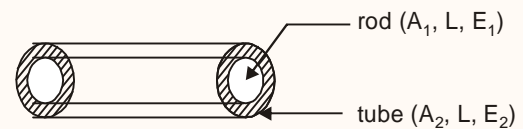

Assume P_1 is the load applied on rod and P_2 is applied on tube.

As ends are connected firmly deflection of rod and tube will be same.

$$\text{So } P = P_1 + P_2 \quad \dots(i)$$

$$\text{and } \Delta L_{\text{rod}} = \Delta L_{\text{tube}} = \Delta L$$

$$\Rightarrow \frac{P_1 L}{A_1 E_1} = \frac{P_2 L}{A_2 E_2} = \frac{P \cdot L}{A_{\text{eq}} E_{\text{eq}}}$$

$$\Rightarrow P_1 = \left(\frac{A_1 E_1}{A_2 E_2} \right) P_2$$

Put value of P_1 in equation (i)

$$P = \left(\frac{A_1 E_1}{A_2 E_2} \right) P_2 + P_2$$

$$\Rightarrow P = \left(\frac{A_1 E_1 + A_2 E_2}{A_2 E_2} \right) P_2$$

$$\Rightarrow P_2 = \frac{A_2 E_2 P}{A_1 E_1 + A_2 E_2} \quad (\text{force on tube})$$

$$\text{Similarly } P_1 = \frac{A_1 E_1 P}{A_1 E_1 + A_2 E_2} \quad (\text{force on rod})$$

71. A weight of 240 N is dropped on to a close-coiled helical spring made up of 18 mm spring steel wire. The spring consists of 22 coils wound to a diameter of 180 mm. If the instantaneous compression is 120 mm, what is the height of drop of the weight, given $G = 88 \times 10^3 \text{ N/mm}^2$?

(a) 450 mm

(b) 300 mm

(c) 250 mm

(d) 150 mm

Ans. (d)

Office Address: F-126, Katwaria Sarai, New Delhi - 110 016
Telephone: 011-41013406, **Mobile:** 8130909220, 9711853908

Web: www.iesmaster.org

E-mail: info@iesmaster.org

SCROLL DOWN



IES MASTER

Institute for Engineers (IES/GATE/PSUs)

Sol.

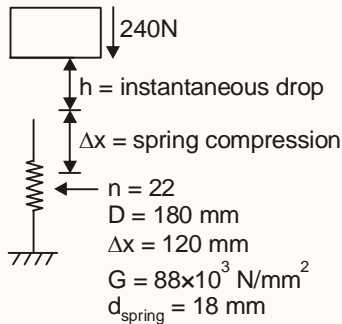

(Potential energy gained via instantaneous drop) + (Potential energy gained against spring compression) = increment in spring energy

$$\Rightarrow mgh + mg\Delta x = \frac{1}{2}k\Delta x^2 \quad \dots(1)$$

Spring constant for close coiled spring

$$k_{\text{spring}} = \frac{Gd^4}{64R^3n} = \frac{88 \times 10^3 \times 18^4}{64 \times 90^3 \times 22} = 9 \text{ N/mm}$$

From equation (1)

$$\Rightarrow 240(h + \Delta x) = \frac{1}{2} \times 9 \times 120^2$$

$$\Rightarrow h + \Delta x = 270 \text{ mm}$$

$$\Rightarrow h = 150 \text{ mm}$$

72. Consider the following statements regarding Ergonomic Design :

1. Reducing the stress on the spinal cord and providing for lesser fatigue-causing sitting arrangements.
2. Arrangements of keys on the computer keyboard towards optimizing finger stress level.
3. Catering to increasing demand to produce more pleasing objects.

Which of the above statements are correct?

- (a) 1 and 2 only (b) 2 and 3 only
(c) 1 and 3 only (d) 1, 2 and 3

Ans. (a)

Sol. Ergonomics is the process of designing or arranging workplace, products and systems so they fit the people who use them.

In another word it is the applied science of equipment design, as for the workplace, intended to maximize productivity by reducing operator fatigue and discomfort.

So, option (a) & (b) are correct. Option (c) is related to aesthetic design.

73. Which type of output device creates coloured images which look and feel like photographs?

- (a) Electrostatic plotter
(b) Laser printer
(c) Dye sublimation printer
(d) Inkjet plotter

Ans. (c)

Sol. A dye-sublimation printer, also called a thermal dye transfer printer, uses heat to transfer coloured dye to specially coated paper. Dye-sublimation printers can create images of photographic quality. Medical or security applications which require very high image, use these printers. However, most home users prefer to purchase a photo printer instead of these dye-sublimation quality printers.

74. Consider the following statements with reference to Six-Sigma :

1. It is a set of techniques and tools for process improvement
2. It postulates that any process must not produce more than 3.4 defect per one million opportunities.
3. It is an initiative of Motorola

Which of the above statements are correct?

- (a) 1 and 2 only (b) 1 and 3 only
(c) 2 and 3 only (d) 1, 2 and 3

Ans. (d)

Office Address: F-126, Katwaria Sarai, New Delhi - 110 016
Telephone: 011-41013406, **Mobile:** 8130909220, 9711853908

Web: www.iesmaster.org

E-mail: info@iesmaster.org

SCROLL DOWN



IES MASTER

Institute for Engineers (IES/GATE/PSUs)

Sol. Six-Sigma is a set of techniques and tools for process improvement. It uses techniques like DMAIC.

Six-Sigma has a process performance of the level of 99.99966%, then it produces 3.4 DPMO i.e., out of one million opportunities the process must not produce more than 3.4 defects.

It was introduced by Bill Smith in 1986, while working at Motorola.

75. Consider the following statements regarding a Grillage Foundation :

1. It is provided for heavily loaded isolated columns.
2. It is treated as a spread foundation.
3. It consists of two sets of perpendicular placed steel columns.

Which of the above statements are correct?

- (a) 1 and 2 only (b) 1 and 3 only
(c) 2 and 3 only (d) 1, 2 and 3

Ans. (a)

Sol.

- Grillage foundation is special type of isolated footing (spread foundation) generally provided for heavily loaded steel stanchions and used in location of poor bearing capacity.
- The load of the column is distributed or spread to a very large area by means of two or more rolled steel sections (generally I section), each layer laid at right angle to each other. Both the layers of the joists (not column) are then embedded in cement concrete.

76. Consider the following statements regarding Insolation :

1. It is the solar radiation that reaches the Earth's surface.
2. It is measured by the amount of solar energy received per square centimeter per minute.

3. It is the amount of solar energy absorbed by the stratosphere.

Which of the above statements are correct?

- (a) 1, 2 and 3 (b) 1 and 2 only
(c) 1 and 3 only (d) 2 and 3 only

Ans. (b)

Sol. Insolation is not the amount of solar energy absorbed by the stratosphere.

Insolation is the power per unit area received from the Sun in the form of electromagnetic radiation.

It is measured by the solar energy received per square centimeter per minute.

77. Consider the following statements regarding Quality Circle :

1. It is a small group of people working in different areas of an organization with multiple expertises.
2. It consists of people who volunteer themselves.
3. It is a human resource development technique.
4. It is a problem-solving forum.

Which of the above statements are correct?

- (a) 2, 3 and 4 only (b) 1, 2 and 3 only
(c) 1, 3 and 4 only (d) 1, 2 and 4 only

Ans. (a)

Sol. Quality circle involves a voluntary group of people generally from the same work area. It leads to increase in problem solving abilities of the workers and enhances knowledge and participation of employees.

78. Consider the following statements :

1. In work breakdown structure, top-down approach is adopted.
2. Duration along critical path is the shortest duration permissible.
3. PERT is probabilistic in its approach.

Office Address: F-126, Katwaria Sarai, New Delhi - 110 016
Telephone: 011-41013406, **Mobile:** 8130909220, 9711853908

Web: www.iesmaster.org

E-mail: info@iesmaster.org

SCROLL DOWN



IES MASTER

Institute for Engineers (IES/GATE/PSUs)

Which of the above statements are correct?

- (a) 1 and 2 only (b) 1 and 3 only
(c) 2 and 3 only (d) 1, 2 and 3

Ans. (d)

Sol. WBS follows top to down approach critical path is the longest path time-wise in the network diagram, whereas it is also the shortest path timewise before which project can not be completed, i.e., shortest duration permissible.

PERT is used for research and development type of projects hence it uses probabilistic approach.

79. Let the sum of the squares of successive integers 0, 1, 2, ..., n - 1, n be denoted by S. Let the sum of the cubes of the same integers be denoted by C. It is desirable that c/s, as n increases in steps of 'unity' from 'zero', is given by the series :

$$\frac{0}{1}, \frac{3}{3}, \frac{9}{5}, \frac{18}{7}, \frac{30}{9}, \dots \text{(for } n = 0, 1, 2, 3, 4, \dots \text{)}.$$

What will this ratio be for n = 8 ?

- (a) $\frac{108}{17}$ (b) $\frac{103}{17}$
(c) $\frac{103}{15}$ (d) $\frac{100}{15}$

Ans. (a)

Sol.
$$\frac{C}{S} = \frac{\left(\frac{n(n+1)}{2}\right)^2}{\frac{n(n+1)(2n+1)}{6}} = \frac{3}{2} \cdot \frac{n(n+1)}{(2n+1)}$$

At n = 1, $\frac{C}{S} = 0 = \frac{0}{1}$

At n = 2, $\frac{C}{S} = 1 = \frac{3}{3}$

At n = 3, $\frac{C}{S} = \frac{9}{5}$ and so on

so At n = 8,
$$\frac{C}{S} = \frac{3}{2} \frac{8(8+1)}{(2 \times 8 + 1)}$$

$$= \frac{3 \times 8 \times 9}{2 \times 17} = \frac{108}{17}$$

80. The plan view at just below window-sill level, but not showing door openings – is shown – of an outpost building of, say, the Forest Department. Section AA extending just a little above ground level GL and fully below ground level is shown. The wall and first footing are of random-rubble masonry in cement mortar; and the lowest part of the foundation is of mass rubble in cement mortar. The total volume of the 40 cm deep footing for the whole building is, nearly

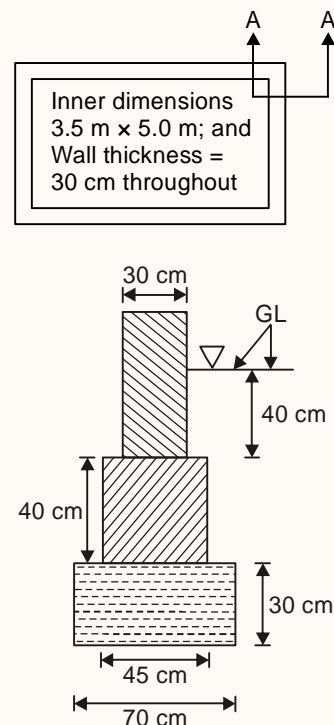

- (a) 3.8 m³ (b) 3.3 m³
(c) 2.8 m³ (d) 2.3 m³

Ans. (b)

Office Address: F-126, Katwaria Sarai, New Delhi - 110 016
Telephone: 011-41013406, **Mobile:** 8130909220, 9711853908

Web: www.iesmaster.org

E-mail: info@iesmaster.org

SCROLL DOWN



IES MASTER

Institute for Engineers (IES/GATE/PSUs)

Sol.

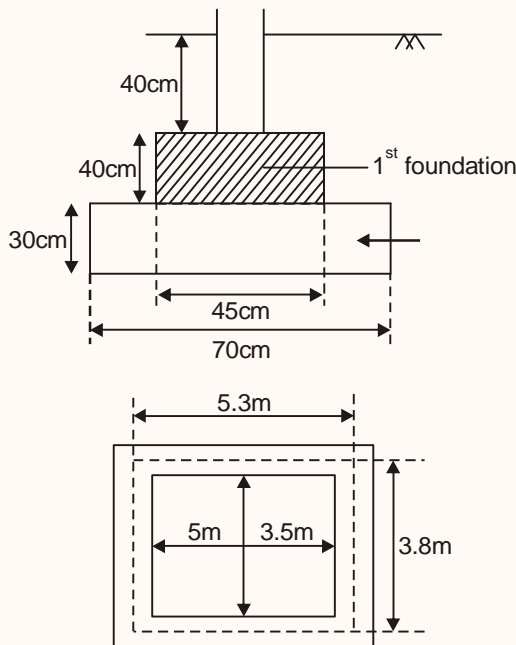

⇒ Rubble-Masonry 40cm deep 1st foundation.

Volume of 40cm deep foundation for whole building

$$= 2 \times (5.3 + 3.8) \times 0.45 \times 0.4$$

$$= 3.276 \text{ m}^3 \approx 3.3 \text{ m}^3$$

81. Government of India had introduced the Consumer Protection Bill, 2015, in the Lok Sabha. The Bill gives the right to consumers to

1. Seek redressal against unfair or restrictive trade practices.
2. File a complaint for overcharging or deceptive charging.

Which of the above is/are included in the Bill?

- (a) 1 only (b) 2 only
(c) Both 1 and 2 (d) Neither 1 nor 2

Ans. (c)

Sol. **Consumer Protection Bill, 2015**

Rights of consumers: The rights of consumers include the right to: (i) be protected against

marketing of goods and services which are hazardous to life and property, (ii) be informed of the quality, quantity, potency, purity, standard and price of goods or services, (iii) be assured of access to a variety of goods or services at competitive prices, and (iv) to seek redressal against unfair or restrictive trade practices.

Consumer Disputes Redressal Commissions:

A consumer can file a complaint with these commissions, regarding: (i) unfair or restrictive trade practices, (ii) defective goods or services, (iii) overcharging or deceptive charging, (iv) the offering of goods or services for sale which may be hazardous to life and safety, and (v) incurring loss due to an unfair contract.

82. Technology Promotion, Development and Utilization Programme implemented by Department of Scientific and Industrial Research has which of the following components?

1. Industrial R and D Promotion Programme.
 2. Flagship Programme
 3. Information Technology and e-Governance
- (a) 1 and 2 only (b) 1 and 3 only
(c) 2 and 3 only (d) 1, 2 and 3

Ans. (d)

Sol. Technology Promotion, Development and Utilization (TPDU) Programme

The specific components of the scheme are:

- Industrial R&D Promotion Programme
- Technology Development and Demonstration Programme (Flagship)
- Technopreneur Promotion Programme (TePP)
- Technology Management Programme
- International Technology Transfer Programme

Office Address: F-126, Katwaria Sarai, New Delhi - 110 016
Telephone: 011-41013406, **Mobile:** 8130909220, 9711853908

Web: www.iesmaster.org

E-mail: info@iesmaster.org

SCROLL DOWN



IES MASTER

Institute for Engineers (IES/GATE/PSUs)

- Consultancy Promotion Programme
- Technology Information Facilitation Programme

- 83.** The Olympic Flame symbolizes
- Unity among various nations of the world
 - Speed, perfection and strength
 - The development of sportsmanship
 - Continuity between ancient and modern games.

Ans. (d)

Sol. Olympic flame is a symbol of the Olympic Games and its origins lie in ancient Greece to celebrate the ancient Olympics. It was again introduced at the Games of the IX Olympiad 1928 in Amsterdam and it has been part of the modern Olympic Games ever since.

It symbolizes the Continuity between new and ancient games.

- 84.** Consider the following statements :
1. IPDS strengthens the distribution network in urban areas while DDUGJY does the same in rural areas.
 2. DELP focuses to substitute LED bulbs for incandescent bulbs.

Which of the above statements is/are correct?

- (a) 1 only
- (b) 2 only
- (c) Both 1 and 2
- (d) Neither 1 nor 2

Ans. (c)

Sol. The objectives of Integrated Power Development Scheme (IPDS) are:

1. Strengthening of sub-transmission and distribution network in the urban areas;
2. Metering of distribution transformers / feeders / consumers in the urban areas.
3. IT enablement of distribution sector and strengthening of distribution network

Deen Dayal Upadhyaya Gram Jyoti Yojana (DDUGJY) aims to initiate much awaited reforms in the rural areas. It focuses on feeder separation (rural households & agricultural) and strengthening of sub-transmission & distribution infrastructure including metering at all levels in rural areas.

The main aim of Domestic Efficient Lighting Programme (DELP) is to urge the people to use LED bulbs in place of incandescent bulbs, tube lights and CFL bulbs as they are more efficient, long lasting and economical in their life cycle duration.

- 85.** Consider the following statements :
- Non-performing assets (NPAs) decline in value when
1. Demand revives in the economy
 2. Capacity utilization increases
 3. Capacity utilization, though substantive, is yet sub-optimal.
 4. Capacity utilization decreases consequent upon merger of units.

Which of the above statements are correct?

- (a) 1, 3 and 4 only
- (b) 1, 2 and 4 only
- (c) 1, 2 and 3 only
- (d) 1, 2, 3 and 4

Ans. (c)

Sol. Non-performing assets (NPAs) decline in value when:

1. Demand revives in the economy: Increase in demand helps the industry to use up more capacity that increases its profits and capital. It can lower the NPAs with ease. Thus the value of NPAs is reduced
2. Capacity utilization increases: Increase in capacity utilization improves the efficiency of the companies. Increase in efficiency will result in more production. More production means more profits which lowers NPAs.

Office Address: F-126, Katwaria Sarai, New Delhi - 110 016
Telephone: 011-41013406, **Mobile:** 8130909220, 9711853908

Web: www.iesmaster.org

E-mail: info@iesmaster.org

SCROLL DOWN



IES MASTER

Institute for Engineers (IES/GATE/PSUs)

$$= \frac{6}{3} \left[\frac{12 + 2 \times 8}{12 + 8} \right]$$

$$= \frac{2 \times 28}{20} = 2.8$$

So correct option is (c)

90. A cantilever beam ABC is shown to a highly exaggerated vertical scale. Horizontally, AB is 2 m long and BC is 0.6 m long. Loads act only in the region AB, and there are no loads in the region BC. Under this load system, the deflection at B is 0.24 cm and the slope of the beam at B is θ , where $\sin \theta = 0.038$. What is the deflection at D, which is midway between B and C?

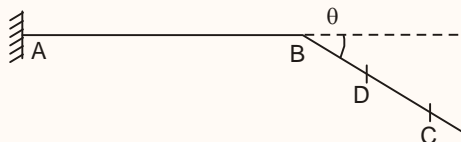

- (a) 0.2406 cm (b) 0.2514 cm
(c) 0.2530 cm (d) 0.2452 cm

Ans. (b)

Sol.

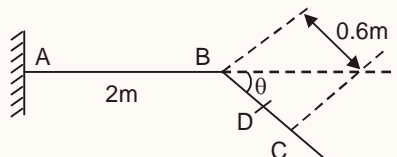

Deflection at D = deflection at B + $\theta_B \times (BD)$

$$= 0.24 \text{ cm} + 0.038 \times \frac{0.6}{2}$$

$$= 0.2514 \text{ cm}$$

91. Given that 0.8 is one root of the equation, $x^3 - 0.6x^2 - 1.84x + 1.344 = 0$. The other roots of this equation will be
- (a) 1.1 and -1.4 (b) -1.2 and 1.4
(c) 1.2 and -1.4 (d) -1.1 and 1.4

Ans. (c)

- Sol. Given equation in $x^3 - 0.6x^2 - 1.84x + 1.344 = 0$

\therefore Only option (c) is satisfying given equation so it is the right answer.

92. The equation, $x^3 - 8x^2 + 37x - 50 = 0$ is factored and it has $(3 + 4i)$ as one of its roots. What is the real root of this equation?
- (a) 2 (b) 4
(c) 6.5 (d) 13

Ans. (a)

- Sol. Given eqn is $x^3 - 8x^2 + 37x - 50 = 0$ only option (a) i.e. $x = 2$ is satisfying above equation so it is the only real root.

93. Circle A is 4 cm in diameter; circle B is 5 cm in diameter. Circle C has its circumference equal to the sum of the circumferences of both A and B together. What will be the ratio of the area of circle C, with respect to the area of circle A and circle B respectively?
- (a) 5.0625 and 1.84 (b) 3.875 and 1.84
(c) 5.0625 and 3.24 (d) 3.875 and 3.24

Ans. (c)

- Sol. $r_A = 2$ so area (A) = $\pi(2)^2 = 4\pi$

$$r_B = \frac{5}{2} \text{ so area (B) } = \pi \left(\frac{5}{2} \right)^2 = \frac{25}{4} \pi$$

ATQ, $2\pi(r_C) = 2\pi r_A + 2\pi r_B$

$$r_C = 2 + \frac{5}{2} = \frac{9}{2}$$

$$\text{so area (C) } = \pi \left(\frac{9}{2} \right)^2 = \frac{81}{4} \pi$$

$$\text{Hence } \frac{C}{A} = \frac{\frac{81}{4} \pi}{4\pi} = \frac{81}{16} = 5.0625$$

$$\& \frac{C}{B} = \frac{\frac{81}{4} \pi}{\frac{25}{4} \pi} = \frac{81}{25} = 3.24$$

Office Address: F-126, Katwaria Sarai, New Delhi - 110 016
Telephone: 011-41013406, Mobile: 8130909220, 9711853908

Web: www.iesmaster.org

E-mail: info@iesmaster.org

SCROLL DOWN



IES MASTER

Institute for Engineers (IES/GATE/PSUs)

94. The 12 digits on the face of a clock are to be represented employing contributions of only the number 9 as either 9 or $\sqrt{9}$. The other prescribed conditions are (i) the least number of uses alone are permitted; and (ii) when alternates are possible, use of 9 will be preferred over use of $\sqrt{9}$, which should be used minimally. How many times would $\sqrt{9}$ have to be used?

- (a) 6 (b) 5
(c) 4 (d) 3

Ans. (a)

Sol.

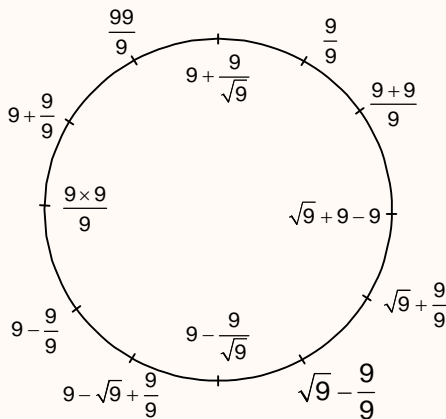

So only six times we have used $\sqrt{9}$.

95. In a particular test, the marks scored by 4 candidates – A, B, C and D are as follows :

- Marks obtained by A and B add to 100;
- Marks obtained by C and D add up to those scored by A;
- B scores 4 times of D;
- D scores 10 marks less than C.

The marks obtained by C will be

- (a) 30 (b) 15
(c) 20 (d) 25

Ans. (d)

Sol. $A + B = 100 \Rightarrow A = 100 - 4D$

$$C + D = A \Rightarrow C = 100 - 4D - D = 100 - 5D$$

$$B = 4D$$

$$D = C - 10 \Rightarrow D = 100 - 5D - 10$$

$$6D = 90 \Rightarrow D = 15$$

$$C = D + 10 = 25$$

96. In a project there are 9 activities : A, B, C, D which are sequential; E, F, G which are sequential; H, K which are sequential. Also E, F, G run parallel to B, C, D; and H, K run parallel to A, B, C, D. Besides these activity dependencies, it is also needful that B be completed before taking up G; A and H be completed before taking up D and K. How many dummies are to be drawn on the activity network?

- (a) 5 (b) 4
(c) 3 (d) 2

Ans. (c)

Sol.

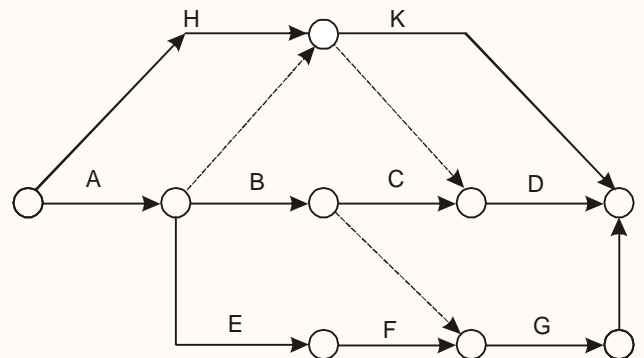

97. What is the form of the function $f(x)$ for the following data?

x	0	1	2	3
f(x)	3	6	11	18

- (a) $x^2 + 2x + 3$ (b) $x^2 - 2x + 3$
(c) $x^2 + 2x - 3$ (d) $x^2 - 2x - 3$

Ans. (a)

Office Address: F-126, Katwaria Sarai, New Delhi - 110 016
Telephone: 011-41013406, Mobile: 8130909220, 9711853908

Web: www.iesmaster.org

E-mail: info@iesmaster.org

SCROLL DOWN

