

**SCIENCE AND TECHNOLOGY  
CLASS X (THEORY)**

**TIME:**  $2\frac{1}{2}$  Hrs.

**MAX. MARKS: 60**

**GENERAL INSTRUCTIONS:**

1. *The question paper consists of two Sections A and B. You are to attempt both the sections.*
2. *The candidates are advised to attempt all the questions of section-A separately and Section –B separately.*
3. *All questions are compulsory.*
4. *There is no overall choice. However, internal choice has been provided in two questions of five marks category and one question of 3 marks category in Section A and one question of 2 marks category and one question of three marks category in Section-B.*
5. *Marks allocated to each question are indicated against it.*
6. *Questions 1 to 4 in Section A and 17, 18 in Section-B are very short answer questions. These are to be answered in one word or one sentence. One mark questions*
7. *Questions 5 to 8 in Section A and 19, 20 in Section-B are short answer questions. These are to be answered in 30-40 words each. Two mark questions*
8. *Questions 9 to 14 in Section A and 21 to 23 in Section-B are also short answer questions. These are to be answered in 40-50 words each. Three mark questions*
9. *Questions 15, 16 in Section A and 24 in Section-B are Long answer questions. These are to be answered in about 70 words each. Five mark questions*

**SECTION – A**

1. In all the non conventional sources of energy what is the major and desirable form of output as the energy?
2. Reena weighs 92.5 Kg. what is her mass?
3. In the expression for rate of reaction what does the negative sign signifies?
4. What is chemical formula for the most commonly used glass, soda glass?
5. We know that the lens may converging or diverging types and the image formed by them is distorted then the real object. But why some people wear those glasses. Briefly explain your answer?
6. What is electric current? What are its types?

7. In a pure metal we never want the impurities to interfere. Is this always true?  
Support your answer with reasons.
8. What are the uses of sulphuric acid?
9. What is homogeneous and heterogeneous reaction? Give an example.
10. Explain the various sign conventions in mirror formula.
11. in the following circuit

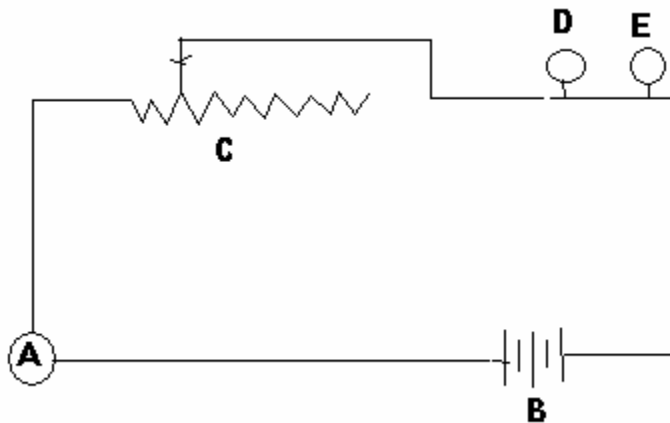

- a) Why we use ammeter (A) not voltmeter?
  - b) What is the function of rheostat?
  - c) Both D and E are bulbs with resistance 30 and 20 ohm when current of 8 ampere will be passed which bulb will glow bright and why.
- 
12. explain with example the following
    - a) Efflorescence
    - b) calcining
  13. a) When we stand under high tension wires. We feel some what pull upwards and sometimes we can see small birds stick to the high tension wires. Why is that so?
    - b) How the intensity of magnetic field can be increased in the electro magnet?
    - c) How earthing is done? (BY:- VIDHUR, LUDHAIANA, 09915089502)
  14. a) Why we call metals as electropositive?
    - b) What is role of activity series in chemistry?
    - c) Name the commonly ore from which copper is extracted?

15. a) Explain with diagram the working of solar cooker?  
b) What are the desirable properties of the fuse wire?
16. a) What is fermentation? Explain this concept with an n example?  
b) What is saponification?  
c) What is tollen reagent?

### **SECTION- B**

17. Which part of roots is involved in exchange of respiratory gases?
18. Name the membrane which covers the lungs?
19. Why the RBC called the soldiers of the body?
20. Define excretion? Which part is responsible for excretion in earthworm?
21. what are the functions of:-  
a) Adrenal  
b) Estrogen  
c) Vasopressin
22. How fertilization occurs in any flowering plant?
23. How do embryological studies provide evidence for evolution?
24. Explain the male reproduction organ with a diagram.