



Set 2

Std. 12
15-01-2018

Max. Marks : 70
Time : 3 hrs.

INSTRUCTIONS:

- (i) Q. Nos. 1 to 5 carry 1 mark each.
- (ii) Q. Nos. 6 to 10 carry 2 marks each.
- (iii) Q. Nos. 11 to 22 carry 3 marks each.
- (iv) Q. No. 23 carries 4 marks.
- (v) Q. Nos. 24 to 26 carry 5 marks each.
- (vi) Use pencil for the diagrams and graphs.
- (vii) Answers should be to the point.
- (viii) Use log tables if necessary

Section A

1. Sketch the graph of current versus voltage in case of a solar cell. Does it offer ohmic resistance or non-ohmic resistance? (1)
2. A plane electromagnetic wave travels in air along Z direction. The electric field intensity changes sinusoidally with an amplitude of 1Vm^{-1} . What is the amplitude of varying magnetic field intensity? (1)
3. A spherical inflated balloon is given an amount of charge 'q' which is distributed uniformly on its surface. What will happen to the charge and charge density if the radius of the balloon increases? (1)
4. Why a transformer can't be used for stepping up dc voltage? (1)
5. A traveller travels from equator to the pole. How does the angle dip change? (1)

Section B

6. A difference of 2.3eV separates two energy levels in atom. What is the frequency of radiation emitted when the atom makes a transition from the upper level to the lower level? (2)
(OR)

The kinetic energy of photo electrons gets doubled when the wave length light incident on the surface changes from λ_1 to λ_2 . Obtain the expressions for threshold wave length λ_0 and work function. (2)

7. A convex lens made up of glass has a power of 10D in air. The lens acts as a diverging lens of focal length 50cm when immersed in a liquid. Calculate the refractive index of the liquid. Given ${}^a\mu_g = 1.5$. (2)
8. What is a Transducer? What do you mean by amplitude modulation explain briefly amplitude modulation with help of schematic diagram? (2)
9. How does Ampere-Maxwell law explain the flow of current through a capacitor when it is being charged by a battery? Write the expression for the displacement current in terms of the rate of change of electric flux? (2)
10. Write two important limitations of Rutherford model of atom. (2)

Section C

11. What is role of electric field and magnetic field in cyclotron? Establish an expression of cyclotron frequency. What is its characteristic? Why is it pre-determined? (3)

12. A resistor of 200Ω and a capacitor of $15\ \mu\text{F}$ are connected in series to a 220V , 50Hz A.C source. Calculate the current in the circuit and the rms voltages across resistor and the capacitor. Is the algebraic sum of these voltages more than the source voltage? If yes resolve the paradox. (3)

Page 2

Pre-Board 2017-18

PHYSICS (Set – 2)

13. (i) Sketch the graph showing the variation of nuclear force between nucleons and distance between them.
 (ii) Distinguish between Nuclear fission and nuclear fusion and give an example for each reaction. (3)
14. Two cells of emf E_1 & E_2 are connected in series as shown. When P. D. across AB and CD are balanced on a potentiometer, the balance lengths were found to be 350 cm & 140 cm respectively. Calculate the ratio of E_1/E_2 and balance length for balancing E_2 . ($E_1 > E_2$) (3)



15. Write the two processes that take place in the formation of a p-n junction. Explain with the help of a diagram, the formation of depletion region and barrier potential in a p-n junction.

(OR)

Draw a labeled diagram of full wave rectifier circuit and briefly explain its working. Draw the input and output wave forms of voltages. Name the device used to get rid of pulsating output. (3)

16. In the following network of capacitances, calculate potential difference across the points 'A' and 'B' (3)

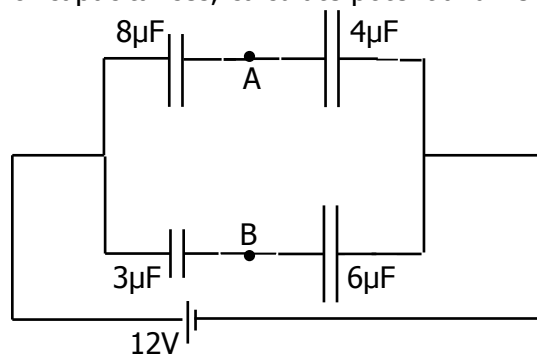

17. Define the term 'amplitude modulation'. Explain any two factors which justify the need for modulating a low frequency base band signal. (3)
18. Using postulates of Bohr's theory of hydrogen atom, show that;
 (i) Radii of orbits increases as n^2 (Where n is number of orbit)
 (ii) The total energy on an in orbit is half its potential energy. (3)
19. (i) Draw a neat circuit diagram needed to amplify a weak signal using a n-p-n transistor as its common emitter configuration with a necessary biasing of the terminal.
 (ii) For a common emitter amplifier, the audio signal voltage across the collector resistance $2\text{k}\Omega$ is 2V . Given current amplification factor of the transistor is 100 , find the input signal voltage and base current if the base resistance is $2\text{k}\Omega$. (3)
20. (i) A wire of length ' l ' carrying a current of ' I ' placed in a uniform magnetic field of ' B '. Derive an expression for the force experienced by the wire.
 (ii) Why two parallel wires carrying the currents in the same direction experience of a mutual force of attraction. (3)

21. A composite light consisting three colours incident on the surface of an isosceles right angled prism as shown in the figure. Given that refractive indices of glass for different colours $\mu_{\text{Blue}} = 1.47$, $\mu_{\text{yellow}} = 1.44$ and $\mu_{\text{red}} = 1.39$. Trace the path the light emerging through the surface AC. (3)

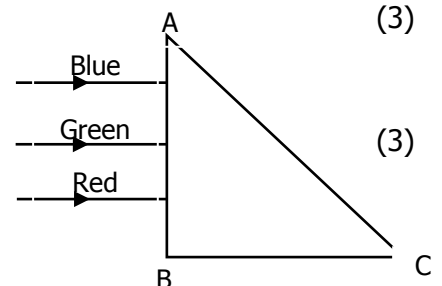

22. (i) Derive the expression for electric field at a point on the equatorial line of an electric dipole.
(ii) Depict the orientation of the dipole stable and unstable equilibrium in a uniform electric field. (3)

Page 3

Pre-Board 2017-18

PHYSICS (Set – 2)

Section D

23. Ashvin and Virat are very good friends studying in class 12. They went to visit an observatory on a hill station. There were some junior students from other school too. One of the junior students got excited after watching the moon through the optical instrument established at the observatory then he asked Virat about the instrument. Virat was able to answer all the questions very patiently.
- (i) Name the instrument established at the observatory.
(ii) Draw a neat diagram to show the path of the light through the instrument.
(iii) Write the formula for its magnifying power.
(iv) What are the values shown by Virat? (4)

Section E

24. (i) Define the term current density of in a current carrying wire. Deduce the relation between current density and the conductivity when a potential difference of 'V' is applied across the conductor of length 'l'.
(ii) An aluminum wire of diameter 0.25cm is connected in series with a copper wire of diameter 0.16cm. A current of 1.0 A is passed through them. Find the (a) current density in aluminum wire. (b) Drift velocity of electrons in copper wire. Given the electron density of conduction electrons in copper is 10^{29}m^{-3} . (2+3)
(OR)
(i) State the principle of a potentiometer. Show the variation of potential difference across the wire versus length of the wire.
(ii) Draw a neat circuit diagram of a potentiometer for the determination of internal resistance of a primary cell. Explain how the internal resistance of a primary is determined and hence derive the formula of internal resistance. (2+3)
25. (i) State the working principle of an A.C. generator. Explain the construction, working and hence derive the expression for emf generated.
(ii) A rectangular coil of area 300cm^2 and 100 turn is rotated about an axis passing through the centre and parallel to the length with angular velocity 120rpm in a uniform magnetic field of strength 300G. Calculate the amplitude of emf. (3+2)
26. (i) What do you mean by interference of light. Write the necessary conditions for obtaining a sustained interference.
(ii) Explain the experimental set up of an Young's double slit experiment to observe interference of light and hence obtain the expression for path difference.
(iii) An Young's double slit experiment is performed in air and fringe width of ' β ' is obtained. What will happen to fringe width when the entire set up is immersed in a liquid of refractive index ' μ '. (2+2+1)
(OR)
(i) Write two essential conditions for diffraction of light.
(ii) Explain diffraction light due to narrow single slit and the information of pattern of fringes on the screen.
(iii) Find the relation for width of central maxima in terms of ' λ ', width of slits 'a' and separation 'D' between slit and the screen.
(iv) If the width of the slit is made double the original width, how does it affect the size and intensity of central maxima? (1+2+1+1)

Physical Constants : $c = 3 \times 10^8 \text{m/s}$ and $h = 6.63 \times 10^{-34} \text{Js}$

-X-X-X-X-X-