

GATE : 2003

EE : Electrical Engineering

Duration : Three Hours

Maximum Marks : 150

Q. 1 - 30 Carry One Mark Each

1. Fig. Q1 shows the waveform of the current passing through an inductor of resistance 1Ω and inductance 2 H . The energy absorbed by the inductor in the first four seconds is

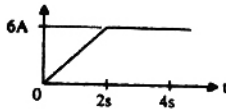

- (a) 144 J
(b) 98 J
(c) 132 J
(d) 168 J
2. A segment of a circuit is shown in Fig. Q2. $V_R = 5 \text{ V}$, $V_C = 4 \sin 2t$. The voltage V_L is given by

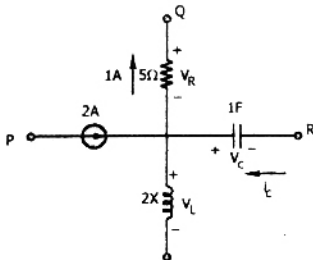

- (a) $3 - 8 \cos 2t$
(b) $32 \sin 2t$
(c) $16 \sin 2t$
(d) $16 \cos 2t$
3. In the Fig. Q3, $Z_1 = 10 \angle -60^\circ$, $Z_2 = 10 \angle 60^\circ$, $Z_3 = 50 \angle 53.13^\circ$. The venv impedance seen from X-Y is

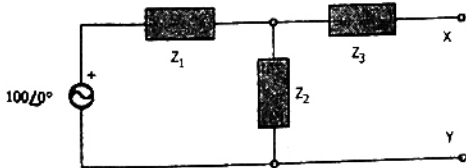

- (a) $56.6 \angle 45^\circ$
(b) $60 \angle 30^\circ$
(c) $70 \angle 30^\circ$
(d) $34.4 \angle 65^\circ$
4. Two conductors are carrying forward and return current of $+I$ and $-I$ as shown in Fig. Q4. The magnetic field intensity \vec{H} at point P is

(a) $\frac{1}{\pi d} \vec{y}$

(b) $\frac{1}{\pi d} \vec{x}$

(c) $\frac{1}{2\pi d} \vec{y}$

(d) $\frac{1}{2\pi d} \vec{x}$

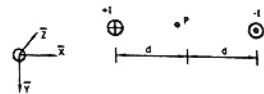

5. Two infinite strips of width $w \text{ m}$ in x direction as shown in Fig. Q5, are carrying forward and return currents of $+I$ and $-I$ in the z direction. The strips are separated by a distance of $x \text{ m}$. The inductance per unit length of the configuration is measured to be $L \text{ H/m}$. If the distance of separation between the strips is now reduced to $x/2 \text{ m}$, the inductance per unit length of the configuration is

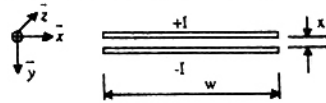

- (a) $2L \text{ H/m}$
(c) $L/2 \text{ H/m}$

- (b) $L/4 \text{ H/m}$
(d) $4L \text{ H/m}$

6. A single phase transformer has a maximum efficiency of 90% at full load and unity power factor. Efficiency at half load at the same power factor is
- (a) 86.7%
(b) 88.26%
(c) 88.9%
(d) 87.8%
7. Group I lists different applications and Group II lists the motors for these applications. Match the application with the most suitable motor and choose the right combination among the choices given thereafter

Group I	Group II
P Food mixer	1 Permanent magnet dc motor
Q Cassette tape recorder	2 Single-phase induction motor
R Domestic water pump	3 Universal motor
S Escalator	4 Three-phase induction motor
	5 DC series motor
	6 Stepper motor

(a) P-3, Q-6, R-4, S-5
(b) P-1, Q-3, R-2, S-4
(c) P-3, Q-1, R-2, S-4
(d) P-3, Q-2, R-1, S-4

8. A stand alone engine driven Synchronous generator is feeding a partly inductive load. A capacitor is now connected across the load to completely nullify the inductive current. For this operating condition

- (a) the field current and fuel input have to be reduced
- (b) the field current and fuel input have to be increased
- (c) the field current has to be increased and fuel input left unaltered
- (d) the field current has to be reduced and fuel input left unaltered

9. Curves X and Y in Fig. Q9 denote open circuit and full-load zero power factor (zpf) characteristics of a synchronous generator. Q is a point on the zpf characteristics at 1.0 p.u. voltage. The vertical distance PQ in Fig. Q. 9 gives the voltage drop across

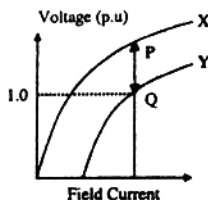

- (a) Synchronous reactance
- (b) Magnetising reactance
- (c) Potier reactance
- (d) Leakage reactance

10. No-load test on a 3-phase induction motor was conducted at different supply voltages and a plot of input power versus voltage was drawn. This curve was extrapolated to intersect the y-axis. This intersection point yields

- (a) Core loss
- (b) Stator copper loss
- (c) Stray load loss
- (d) Friction and windage loss

11. Bundled conductors are mainly used in high voltage overhead transmission lines to

- (a) reduce transmission line losses
- (b) increase mechanical strength of the line
- (c) reduce corona
- (d) reduce sag

12. A power system consists of 300 buses out of which 20 buses are generator buses, 25 buses are the ones with reactive power support and 15 buses are the ones with fixed shunt capacitors. All the other buses are load buses. It is proposed to perform a loadflow analysis for the system using Newton-Raphson method. The size of the Newton-Raphson Jacobian matrix is

- (a) 553×553
- (b) 540×540
- (c) 555×555
- (d) 554×554

13. Choose two appropriate auxiliary components of a HVDC transmission system from the following

- P D.C. line inductor
 - Q A.C. line inductor
 - R Reactive power sources
 - S Distance relays on D.C. line
 - T Series capacitance on A.C. line
- (a) P and Q
 - (b) P and R
 - (c) Q and S
 - (d) S and T

14. A round rotor generator with internal voltage $E_1 = 2.0$ p.u. and $X = 1.1$ p.u. is connected to a round rotor synchronous motor with internal voltage $E_2 = 1.3$ p.u. and $X = 1.2$ p.u. The reactance of the line connecting the generator to the motor is 0.5 p.u. When the generator supplies 0.5 p. u. power, the rotor angle difference between the machines will be

- (a) 57.42°
- (b) 1°
- (c) 32.58°
- (d) 122.58°

15. The interrupting time of a circuit breaker is the period between the instant of

- (a) initiation of short circuit and the arc extinction on an opening operation
- (b) energizing of the trip circuit and the arc extinction on an opening operation
- (c) initiation of short circuit and the parting of primary arc contacts
- (d) energizing of the trip circuit and the parting of primary arc contacts

16. The variation of drain current with gate-to-source voltage (I_D - V_{GS} characteristic) of a MOSFET is shown in Fig. Q16. The MOSFET is

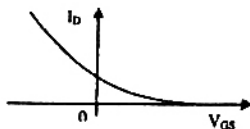

- (a) an n-channel depletion mode device
- (b) an n-channel enhancement mode device
- (c) a p-channel depletion mode device
- (d) a p-channel enhancement mode device

17. In the circuit of Fig. Q17, assume that the transistor has $h_{FE} = 99$ and $V_{BE} = 0.7$ V. The value of collector current I_C of the transistor is approximately

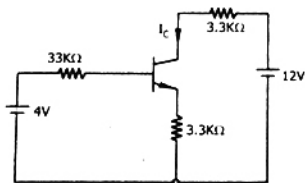

20. When a program is being executed in an 8085 microprocessor, its Program Counter contains
- the number of instructions in the current program that have already been executed
 - the total number of instructions in the program being executed
 - the memory address of the instruction that is being currently executed
 - the memory address of the instruction that is to be executed next
21. A control system is defined by the following mathematical relationship

- (a) $[3.3/3.3]$ mA (b) $[3.3/(3.3 + .33)]$ mA
 (c) $[3.3/33]$ mA (d) $[3.3/(33 + 3.3)]$ mA

$$\frac{d^2x}{dt^2} + 6\frac{dx}{dt} + 5x = 12(1 - e^{-2t})$$

The response of the system as $t \rightarrow \infty$ is

- (a) $x = 6$ (b) $x = 2$
 (c) $x = 2.4$ (d) $x = -2$

18. For the circuit of Fig. Q18 with an ideal operational amplifier, the maximum phase shift of the output V_{out} with reference to the input V_{in} is

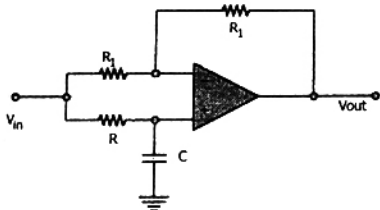

22. A lead compensator used for a closed loop controller has the following transfer function

$$\frac{K\left(1 + \frac{s}{a}\right)}{\left(1 + \frac{s}{b}\right)}$$

For such a lead compensator

- (a) $a < b$ (b) $b < a$
 (c) $a > Kb$ (d) $a < Kb$

19. Fig. Q19 shows a 4 to 1 MUX to be used to implement the sum S of a 1-bit full adder with input bits P and Q and the carry input C_{in} . Which of the following combinations of inputs to I_0, I_1, I_2 and I_3 of the MUX will realize the sum S ?

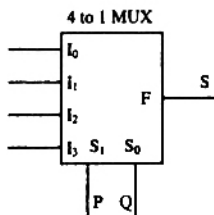

23. A second order system starts with an initial condition of $\begin{bmatrix} 2 \\ 3 \end{bmatrix}$ without any external input. The state transition matrix for the system is given

by $\begin{bmatrix} e^{-2t} & 0 \\ 0 & e^{-t} \end{bmatrix}$. The state of the system at the end

of 1 second is given by

(a) $\begin{bmatrix} 0.271 \\ 1.100 \end{bmatrix}$ (b) $\begin{bmatrix} 0.135 \\ 0.368 \end{bmatrix}$

(c) $\begin{bmatrix} 0.271 \\ 0.736 \end{bmatrix}$ (d) $\begin{bmatrix} 0.135 \\ 1.100 \end{bmatrix}$

- (a) $I_0 = I_1 = C_{in}; I_2 = I_3 = \bar{C}_{in}$
 (b) $I_0 = I_1 = \bar{C}_{in}; I_2 = I_3 = C_{in}$
 (c) $I_0 = I_3 = C_{in}; I_1 = I_2 = \bar{C}_{in}$
 (d) $I_0 = I_3 = \bar{C}_{in}; I_1 = I_2 = C_{in}$

24. A Manganin swamp resistance is connected in series with a moving coil ammeter consisting of a milli-ammeter and a suitable shunt in order to
- minimise the effect of temperature variation
 - obtain large deflecting torque
 - reduce the size of the meter
 - minimise the effect of stray magnetic fields

25. The effect of stray magnetic fields on the actuating torque of a portable instrument is maximum when the operating field of the instrument and the stray fields are

- (a) perpendicular (b) parallel
(c) inclined at 60° (d) inclined at 30°

26. A reading of 120 is obtained when a standard inductor was connected in the circuit of a Q-meter and the variable capacitor is adjusted to a value of 300 pF. A lossless capacitor of unknown value C_1 is then connected in parallel with the variable capacitor and the same reading was obtained when the variable capacitor is readjusted to a value of 200 pF. The value of C_1 in pF is

- (a) 100 (b) 200
(c) 300 (d) 500

27. Fig. Q27 shows a thyristor with the standard terminations of anode (A), cathode (K), gate (G) and the different junctions named J1, J2 and J3. When the thyristor is turned on and conducting

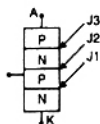

- (a) J1 and J2 are forward biased and J3 is reverse biased
(b) J1 and J3 are forward biased and J2 is reverse biased
(c) J1 is forward biased and J2 and J3 are reverse biased
(d) J1, J2, and J3 are all forward biased

28. Fig. Q28 shows a MOSFET with an integral body diode. It is employed as a power switching device in the ON and OFF states through appropriate control. The ON and OFF states of the switch are given on the V_{DS} - I_S plane by

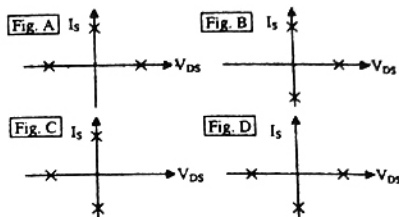
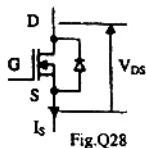

- (a) Fig. A (b) Fig. B
(c) Fig. C (d) Fig. D

29. The speed/torque regimes in a dc motor and the control methods suitable for the same are given respectively in Group I and Group II

Group I	Group II
P Field Control	1 Below base speed
Q Armature Control	2 Above base speed
	3 Above base torque
	4 Below base torque

The match between the control method and the speed/torque regime is as follows

- (a) P-1 ; Q-3 (b) P-2 ; Q-1
(c) P-2 ; Q-3 (d) P-1 ; Q-4

30. A fully controlled natural commutated 3-phase bridge rectifier is operating with a firing angle $\alpha = 30^\circ$. The peak to peak voltage ripple expressed as a ratio of the peak output dc voltage at the output of the converter bridge is

- (a) 0.5 (b) $\frac{\sqrt{3}}{2}$
(c) $\left(1 - \frac{\sqrt{3}}{2}\right)$ (d) $\sqrt{3} - 1$

Q. 31- 90 carry two marks each

31. In the circuit of Fig. Q31, the magnitudes of V_L and V_C are twice that of V_R . The inductance of the coil is

- (a) 2.14 mH
(b) 5.30 H
(c) 3.18 mH
(d) 1.32 H

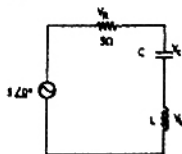

32. In Fig. Q32, the potential difference between points P and Q is

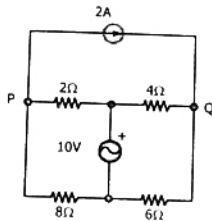

- (a) 12 V
(b) 10 V
(c) -6 V
(d) 8 V

33. Two ac sources feed a common variable resistive load as shown in Fig. Q33. Under the maximum power transfer condition, the power absorbed by the load resistance R_L is

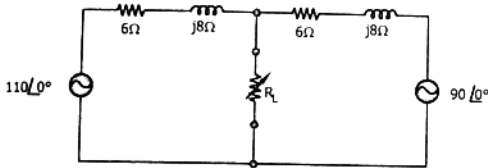

- (a) 2200 W
(b) 1250 W
(c) 1000 W
(d) 625 W

34. In Fig. Q34, the value of R is

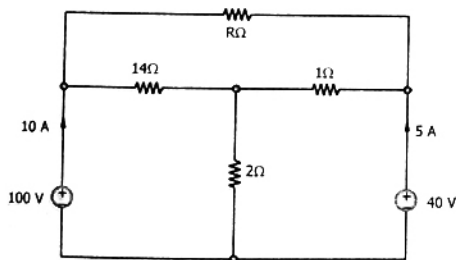

- (a) 10 Ω
(b) 18 Ω
(c) 24 Ω
(d) 12 Ω

35. A balanced delta connected load of $(8 + j6) \Omega$ per phase is connected to a 400 V, 50 Hz, 3-phase supply lines. If the input power factor is to be improved to 0.9 by connecting a bank of star connected capacitors the required kVAR of the bank is

- (a) 42.7
(b) 10.2
(c) 28.8
(d) 38.4

36. In the circuit shown in Fig. Q36, the switch S is closed at time $t = 0$. The voltage across the inductance at $t = 0^+$, is

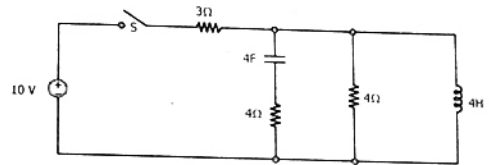

- (a) 2 V
(b) 4 V
(c) -6 V
(d) 8 V

37. The h -parameters for a two-port network are

$$\begin{bmatrix} E_1 \\ I_2 \end{bmatrix} = \begin{bmatrix} h_{11} & h_{12} \\ h_{21} & h_{22} \end{bmatrix} \begin{bmatrix} I_1 \\ E_2 \end{bmatrix}$$

For the two-port network shown in Fig. Q37, the value of h_{12} is given by

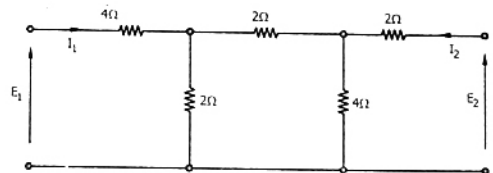

- (a) 0.125
(b) 0.167
(c) 0.625
(d) 0.25

38. A point charge of $+1 \text{ nC}$ is placed in a space with a permittivity of $8.85 \times 10^{-12} \text{ F/m}$ as shown in Fig. Q38. The potential difference V_{PQ} between two points P and Q at distances of 40 mm and 20 mm respectively from the point charge is

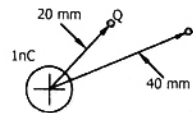

- (a) 0.22 kV
(b) -225 V
(c) -2.24 kV
(d) 15 V

39. A parallel plate capacitor has an electrode area of 100 mm^2 , with a spacing of 0.1 mm between the electrodes. The dielectric between the plates is air with a permittivity of $8.85 \times 10^{-12} \text{ F/m}$. The charge on the capacitor is 100 V. The stored energy in the capacitor is

- (a) 8.85 pJ
(b) 440 pJ
(c) 22.1 nJ
(d) 44.3 nJ

40. A composite parallel plate capacitor is made up of two different dielectric materials with different thicknesses (t_1 and t_2) as shown in Fig. Q40. The two different dielectric materials are separated by a conducting foil F. The voltage of the conducting foil is

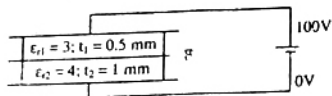

- (a) 52 V
(b) 60 V
(c) 57 V
(d) 33 V

41. Fig. Q41 shows an ideal single-phase transformer. The primary and secondary coils are wound on the core as shown. Turns ratio (N_1/N_2) = 2. The correct phasors of voltages E_1 , E_2 , currents I_1 , I_2 and core flux Φ are as shown in

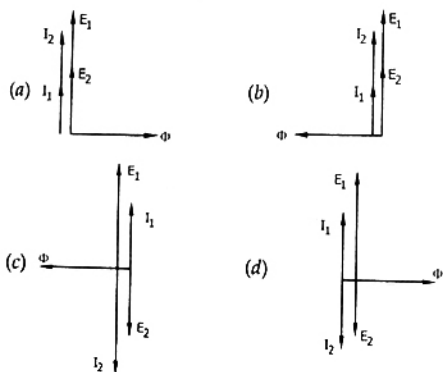
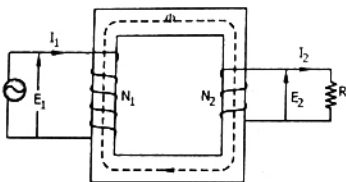

Fig. D

(a) Fig. A

(b) Fig. B.

(c) Fig. C

(d) Fig. D

42. To conduct load test on a dc shunt motor, it is coupled to a generator which is identical to the motor. The field of the generator is also connected to the same supply source as the motor. The armature of the generator is connected to a load resistance. The armature resistance is 0.02 p.u. Armature reaction and mechanical losses can be

neglected. With rated voltage across the motor, the load resistance across the generator is adjusted to obtain rated armature current in both motor and generator. The p.u. value of this load resistance is

- (a) 1.0
(b) 0.98
(c) 0.96
(d) 0.94

43. Fig. Q43 shows a Δ -Y connected 3-phase distribution transformer used to step down the voltage from 11000 V to 415 V line-to-line. It has two switches S_1 and S_2 . Under normal conditions S_1 is closed and S_2 is open. Under certain special conditions S_1 is open and S_2 is closed. In such a case the magnitude of the voltage across the LV terminals a and c is

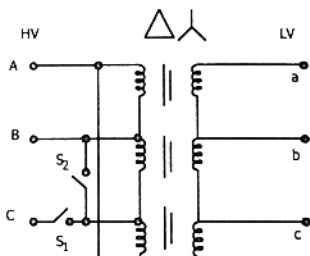

- (a) 240 V
(b) 480 V
(c) 415 V
(d) 0 V

44. Fig. Q44 shows an ideal three-winding transformer. The three windings 1, 2, 3 of the transformer are wound on the same core as shown. The turns ratio $N_1:N_2:N_3$ is 4:2:1. A resistor of $10\ \Omega$ is connected across winding-2. A capacitor of reactance $2.5\ \Omega$ is connected across winding-3. Winding-1 is connected across a 400 V, ac supply. If the supply voltage phasor $V_1 = 400\angle 0^\circ$, the supply current phasor I_1 is given by

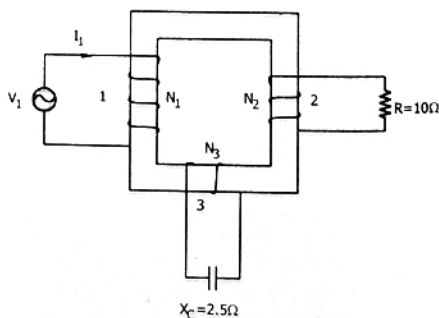

- (a) $(-10 + j10)$ A
(b) $(-10 - j10)$ A
(c) $(10 + j10)$ A
(d) $(10 - j10)$ A

45. Following are some of the properties of rotating electrical machines

- P Stator winding current is dc, rotor winding current is ac
 Q Stator winding current is ac, rotor winding current is dc
 R Stator winding current is ac, rotor winding current is ac
 S Stator has salient poles and rotor has commutator
 T Rotor has salient poles and sliprings and stator is cylindrical
 U Both stator and rotor have poly-phase windings
- DC machines Synchronous machines Induction machines

- (a) P.S Q. T R. U
 (b) Q. U P. T R. S
 (c) P. S R. U Q. T
 (d) R. S Q. U P. T

46. When Stator and Rotor windings of a 2-pole rotating electrical machine are excited, each would produce a sinusoidal mmf distribution in the airgap with peak values F_s and F_r respectively. The rotor mmf lags stator mmf by a space angle δ at any instant as shown in Fig. Q46. Thus, half of stator and rotor surfaces will form one pole with the other half forming the second pole. Further, the direction of torque acting on the rotor can be clockwise or counter-clockwise

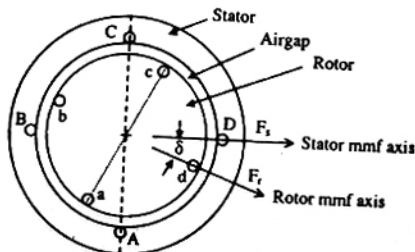

The following Table gives four sets of statements as regards poles and torque. Select the correct set corresponding to the mmf axes as shown in Fig. 46.

Stator Surface ABC forms	Stator Surface CDA forms	Rotor Surface cda forms	Rotor Surface cda forms	Torque is
(a) North Pole	South Pole	North Pole	South Pole	Clockwise
(b) South Pole	North Pole	North Pole	South Pole	Counter Clockwise
(c) North Pole	South Pole	South Pole	North Pole	Counter Clockwise
(d) South Pole	North Pole	South Pole	North Pole	Clockwise

47. A 4-pole, 3-phase, double-layer winding is housed in a 36-slot stator for an ac machine with 60° phase spread. Coil span is 7 slot pitches. Number of slots in which top and bottom layers belong to different phases is

- (a) 24 (b) 18
 (c) 12 (d) 0

48. A 3-phase Induction Motor is driving a constant torque load at rated voltage and frequency. If both voltage and frequency are halved, following statements relate to the new condition if stator resistance, leakage reactance and core loss are ignored

- P The difference between synchronous speed and actual speed remains same
 Q The airgap flux remains same
 R The stator current remains same
 S The p.u. slip remains same

Among the above, correct statements are

- (a) All (b) P, Q & R
 (c) Q, R & S (d) P & S

49. A single phase induction motor with only the main winding excited would exhibit the following response at synchronous speed

- (a) Rotor current is zero
 (b) Rotor current is non-zero and is at slip frequency
 (c) Forward and backward rotating fields are equal
 (d) Forward rotating field is more than the backward rotating field

50. A dc series motor driving an electric train faces a constant power load. It is running at rated speed and rated voltage. If the speed has to be brought down to 0.25 p.u. the supply voltage has to be approximately brought down to

- (a) 0.75 p.u. (b) 0.5 p.u.
 (c) 0.25 p.u. (d) 0.125 p.u.

51. The ABCD parameters of a 3-phase overhead transmission line are $A = D = 0.9 \angle 0^\circ$, $B = 200 \angle 90^\circ \Omega$ and $C = 0.95 \times 10^{-3} \angle 90^\circ S$. At no-load condition a shunt inductive reactor is connected at the receiving end of the line to limit the receiving-end voltage to be equal to the sending-end voltage. The ohmic value of the reactor is

- (a) $\infty \Omega$ (b) 2000 Ω
 (c) 105.26 Ω (d) 1052.6 Ω

52. A surge of 20 kV magnitude travels along a lossless cable towards its junction with two identical lossless overhead transmission lines. The inductance and the capacitance of the cable are 0.4 mH and 0.5 μ F per km. The inductance and capacitance of the overhead transmission lines are 1.5 mH and 0.015 μ F per km. The magnitude of the voltage at the junction due to surge is
- (a) 36.72 kV (b) 18.36 kV
(c) 5.72 kV (d) 33.93 kV

53. A distribution system is shown in Fig. Q53 with load currents as marked. The two ends of the feeder are fed by voltage sources such that $V_P - V_Q = 3$ V. The value of the voltage V_P for a minimum voltage of 220 V at any point along the feeder is

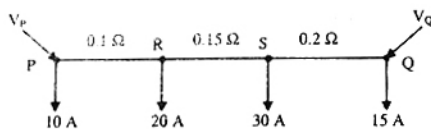

- (a) 225.89 V (b) 222.89 V
(c) 220.0 V (d) 228.58 V

54. A 3-phase, 11-kV generator feeds power to a constant power unity power factor load of 100 MW through a 3-phase transmission line. The line-to-line voltage at the terminals of the machine is maintained constant at 11 kV. The per unit positive sequence impedance of the line based on 100 MVA and 11 kV is $j0.2$. The line to line voltage at the load terminals is measured to be less than 11 kV. The total reactive power to be injected at the terminals of the load to increase the line-to-line voltage at the load terminals to 11 kV is
- (a) 100 MVAR (b) 10.1 MVAR
(c) -100 MVAR (d) 10.1 MVAR
55. The bus impedance matrix of a 4-bus power system is given by

$$Z_{bus} = \begin{bmatrix} j0.3435 & j0.2860 & j0.2723 & j0.2277 \\ j0.2860 & j0.3408 & j0.2586 & j0.2414 \\ j0.2723 & j0.2586 & j0.2791 & j0.2209 \\ j0.2277 & j0.2414 & j0.2209 & j0.2791 \end{bmatrix}$$

A branch having an impedance of $j0.2 \Omega$ is connected between bus 2 and the reference. Then the values of $Z_{22, new}$ and $Z_{23, new}$ of the bus impedance matrix of the modified network are respectively

- (a) $j0.5408 \Omega$ and $j0.4586 \Omega$
(b) $j0.1260 \Omega$ and $j0.0956 \Omega$
(c) $j0.5408 \Omega$ and $j0.0956 \Omega$
(d) $j0.1260 \Omega$ and $j0.1630 \Omega$

56. A 20-MVA, 6.6-kV, 3-phase alternator is connected to a 3-phase transmission line. The per unit positive-sequence, negative-sequence and zero-sequence impedances of the alternator are $j0.1$, $j0.1$ and $j0.04$ respectively. The neutral of the alternator is connected to ground through an inductive reactor of $j0.05$ p.u. The per unit positive-, negative- and zero-sequence impedances of the transmission line are $j0.1$, $j0.1$ and $j0.3$, respectively. All per unit values are based on the machine ratings. A solid ground fault occurs at one phase of the far end of the transmission line. The voltage of the alternator neutral with respect to ground during the fault is
- (a) 513.8 V (b) 889.9 V
(c) 1112.0 V (d) 642.2 V

57. Incremental fuel costs (in some appropriate unit) for a power plant consisting of three generating units are

$$IC_1 = 20 + 0.3 P_1, IC_2 = 30 + 0.4 P_2, IC_3 = 30$$

where P_i is the power in MW generated by unit i , for $i = 1, 2$ and 3.

Assume that all the three units are operating all the time. Minimum and maximum loads on each unit are 50 MW and 300 MW respectively. If the plant is operating on economic load dispatch to supply the total power demand of 700 MW, the power generated by each unit is

- (a) $P_1 = 242.86$ MW ; $P_2 = 157.14$ MW ; and $P_3 = 300$ MW
(b) $P_1 = 157.14$ MW ; $P_2 = 242.86$ MW ; and $P_3 = 300$ MW
(c) $P_1 = 300.0$ MW ; $P_2 = 300.0$ MW ; and $P_3 = 100$ MW
(d) $P_1 = 233.3$ MW ; $P_2 = 233.3$ MW ; and $P_3 = 233.4$ MW

58. A list of relays and the power system components protected by the relays are given in Group I and Group II respectively. Choose the correct match from the four choices given below

Group I	Group II
P Distance relay	1 Transformers
Q Under frequency relay	2 Turbines
R Differential relay	3 Busbars
S Buchholz relay	4 Shunt capacitors
	5 Alternators
	6 Transmission lines

- (a) P-6, Q-5, R-3, S-1 (b) P-4, Q-3, R-2, S-1
(c) P-5, Q-2, R-1, S-6 (d) P-6, Q-4, R-5, S-3

59. A generator delivers power of 1.0 p.u. to an infinite bus through a purely reactive network. The maximum power that could be delivered by the generator is 2.0 p.u. A three-phase fault occurs at the terminals of the generator which reduces the generator output to zero. The fault is cleared after t_f second. The original network is then restored. The maximum swing of the rotor angle is found to be $\delta_{max} = 110$ electrical degree. Then the rotor angle in electrical degrees at $t = t_f$ is

- (a) 55 (b) 70
(c) 69.14 (d) 72.4

60. A three-phase alternator generating unbalanced voltages is connected to an unbalanced load through a 3-phase transmission line as shown in Fig. Q60. The neutral of the alternator and the star point of the load are solidly grounded. The phase voltages of the alternator are $E_a = 10 \angle 0^\circ$ V, $E_b = 10 \angle -90^\circ$ V, $E_c = 10 \angle 120^\circ$ V. The positive-sequence component of the load current is

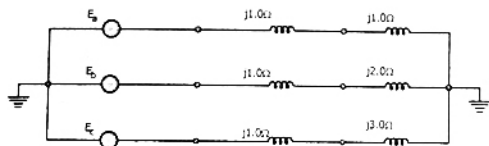

- (a) 1.310 $\angle -107^\circ$ A (b) 0.332 $\angle -120^\circ$ A
(c) 0.996 $\angle -120^\circ$ A (d) 3.510 $\angle -81^\circ$ A

61. For the n-channel enhancement MOSFET shown in Fig. Q61, the threshold voltage $V_{in} = 2$ V. The drain current I_D of the MOSFET is 4 mA when the drain resistance R_D is 1 k Ω . If the value of R_D is increased to 4 k Ω , drain current I_D will become

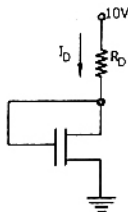

- (a) 2.8 mA (b) 2.0 mA
(c) 1.4 mA (d) 1.0 mA

62. Assuming the operational amplifier to be ideal, the gain V_{out}/V_{in} for the circuit shown in Fig. Q.62 is

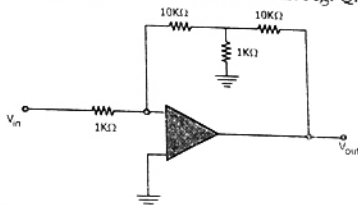

- (a) -1 (b) -20
(c) -100 (d) -120

63. A voltage signal $10 \sin \omega t$ is applied to the circuit with ideal diodes, as shown in Fig. Q63. The maximum, and minimum values of the output waveform V_{out} of the circuit are respectively 10 k ω Ω.

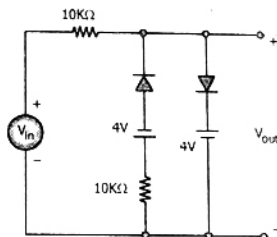

- (a) +10 V and -10 V (b) +4 V and -4 V
(c) +7 V and -4 V (d) +4 V and -7 V

64. The circuit of Fig. Q64 shows a 555 Timer IC connected as an astable multivibrator. The value of the capacitor C is 10 nF. The values of the resistors R_A and R_B for a frequency of 10 kHz and a duty cycle of 0.75 for the output voltage waveform are

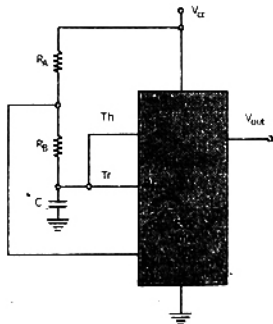

- (a) $R_A = 3.62$ k Ω , $R_B = 3.62$ k Ω
(b) $R_A = 3.62$ k Ω , $R_B = 7.25$ k Ω
(c) $R_A = 7.25$ k Ω , $R_B = 3.62$ k Ω
(d) $R_A = 7.25$ k Ω , $R_B = 7.25$ k Ω

65. The simplified block diagram of a 10-bit A/D converter of dual slope integrator type is shown in Fig. Q65. The 10-bit counter at the output is clocked by a 1 MHz clock. Assuming negligible timing overhead for the control logic, the maximum frequency of the analog signal that can be converted using this A/D converter is approximately

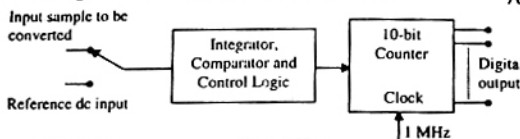

- (a) 2 kHz (b) 1 kHz
(c) 500 Hz (d) 250 Hz

66. The Boolean expression $\overline{X}Y\overline{Z} + \overline{X}YZ + XY\overline{Z} + X\overline{Y}Z + XYZ$ can be simplified to

- (a) $X\overline{Z} + \overline{X}Z + YZ$ (b) $XZ + \overline{Y}Z + Y\overline{Z}$
(c) $\overline{X}Y + YZ + XZ$ (d) $\overline{X}Y + Y\overline{Z} + \overline{X}Z$

67. The shift register shown in Fig. Q67 is initially loaded with the bit pattern 1010. Subsequently the shift register is clocked, and with each clock pulse the pattern gets shifted by one bit position to the right. With each shift, the bit at the serial input is pushed to the left most position (msb). After how many clock pulses will the content of the shift register become 1010 again?

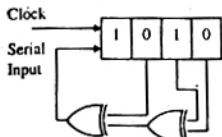

- (a) 3 (b) 7
(c) 11 (d) 15

68. An X-Y flip flop, whose Characteristic Table is given below is to be implemented using a J-K flip flop

X	Y	Q_{n+1}
0	0	1
0	1	Q_n
1	0	Q_n
1	1	0

This can be done by making

- (a) $J = X, K = \overline{Y}$ (b) $J = \overline{X}, K = Y$
(c) $J = Y, K = \overline{X}$ (d) $J = \overline{Y}, K = X$

69. A memory system has a total of 8 memory chips, each with 12 address lines and 4 data lines. The total size of the memory system is
- (a) 6 kbytes (b) 32 kbytes
(c) 48 kbytes (d) 64 kbytes

70. The following program is written for an 8085 microprocessor to add two bytes located at memory addresses 1FFE and 1FFF

```
LXI          H, 1FFE
MOV         B, M
INR        L
MOV         M, A
ADD        B
INR        L
MOV         M, A
XOR        A
```

On completion of the execution of the program, the result of addition is found

- (a) in the register A
(b) at the memory address 1000
(c) at the memory address 1F00
(d) at the memory address 2000

71. A control system with certain excitation is governed by the following mathematical equation

$$\frac{d^2x}{dt^2} + \frac{1}{2} \frac{dx}{dt} + \frac{1}{18} x = 10 + 5e^{-4t} + 2e^{-5t}$$

The natural time constants of the response of the system are

- (a) 2s and 5s (b) 3s and 6s
(c) 4s and 5s (d) 1/3s and 1/6s

72. The block diagram shown in Fig Q72-73 gives a unity feedback closed loop control system. The steady state error in the response of the above system to unit step input is

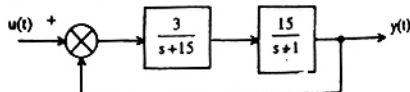

- (a) 25% (b) 0.75%
(c) 6% (d) 33%

73. The roots of the closed loop characteristic equation of the system shown in Fig Q72-73 are

- (a) -1 and -15 (b) 6 and 10
(c) -4 and -15 (d) -6 and 10

74. The following equation defines a separately excited dc motor in the form of a differential equation

$$\frac{d^2\omega}{dt^2} + \frac{B}{J} \frac{d\omega}{dt} + \frac{K^2}{LJ} \omega = \frac{K}{LJ} V_a$$

The above equation may be organized in the state-space form as follows

$$\begin{bmatrix} \frac{d^2\omega}{dt^2} \\ \frac{d\omega}{dt} \\ \omega \end{bmatrix} = P \begin{bmatrix} \frac{d\omega}{dt} \\ \omega \end{bmatrix} + QV_a$$

where the P matrix is given by

$$(a) \begin{bmatrix} -\frac{B}{J} & -\frac{K^2}{LJ} \\ 1 & 0 \end{bmatrix} \quad (b) \begin{bmatrix} -\frac{K^2}{LJ} & -\frac{B}{J} \\ 0 & 1 \end{bmatrix}$$

$$(c) \begin{bmatrix} 0 & 1 \\ -\frac{K^2}{LJ} & -\frac{B}{J} \end{bmatrix} \quad (d) \begin{bmatrix} 1 & 0 \\ -\frac{B}{J} & -\frac{K^2}{LJ} \end{bmatrix}$$

75. The loop gain GH of a closed loop system is given

$$\text{by the following expression } \frac{K}{s(s+2)(s+4)}$$

The value of K for which the system just becomes unstable is

- (a) K = 6 (b) K = 8
(c) K = 48 (d) K = 96
76. The asymptotic Bode plot of the transfer function

$\frac{K}{1 + \frac{s}{a}}$ is given in Fig. Q76. The error in phase angle

and dB gain at a frequency of $\omega = 0.5a$ are respectively

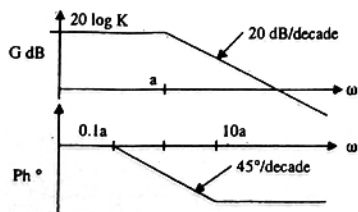

- (a) 4.9°, 0.97 dB (b) 5.7°, 3 dBs
(c) 4.9°, 3 dB (d) 5.7°, 0.97 dB

77. The block diagram of a control system is shown in Fig. Q77. The transfer function $G(s) = Y(s)/U(s)$ of the system is

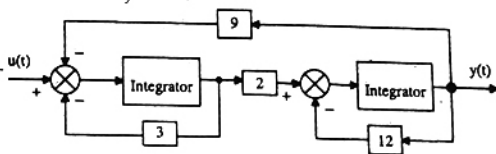

$$(a) \frac{1}{18 \left(1 + \frac{s}{12}\right) \left(1 + \frac{s}{3}\right)}$$

$$(b) \frac{1}{27 \left(1 + \frac{s}{6}\right) \left(1 + \frac{s}{9}\right)}$$

$$(c) \frac{1}{27 \left(1 + \frac{s}{12}\right) \left(1 + \frac{s}{9}\right)}$$

$$(d) \frac{1}{27 \left(1 + \frac{s}{9}\right) \left(1 + \frac{s}{3}\right)}$$

78. The items in Group I represent the various types of measurements to be made with a reasonable accuracy using a suitable bridge. The items in Group II represent the various bridges available for this purpose. Select the correct choice of the item in Group II for the corresponding item in Group I from the following

Group I	Group II
P Resistance in the milli-Ohm range	1 Wheatstone Bridge
Q Low values of Capacitance	2 Kelvin Double Bridge
R Comparison of resistances which are nearly equal	3 Schering Bridge
S Inductance of a coil with a large time-constant	4 Wien's Bridge
	5 Hay's Bridge
	6 Carey-Foster Bridge

(a) P = 2, Q = 3, R = 6, S = 5,
(b) P = 2, Q = 6, R = 4, S = 5,
(c) P = 2, Q = 3, R = 5, S = 4,
(d) P = 1, Q = 3, R = 2, S = 6,

79. A rectifier type ac voltmeter consists of a series resistance R_x , an ideal full-wave rectifier bridge and a PMMC instrument as shown in Fig.Q79. The

internal resistance of the instrument is $100\ \Omega$ and a full scale deflection is produced by a dc current of $1\ \text{mA}$. The value of R_s required to obtain full scale deflection with an ac voltage of $100\ \text{V}$ (rms) applied to the input terminals is

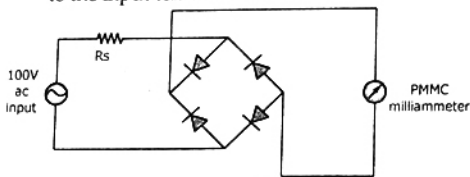

- (a) $63.56\ \Omega$ (b) $89.93\ \Omega$
 (c) $89.93\ \text{k}\Omega$ (d) $141.3\ \text{k}\Omega$

80. A wattmeter reads $400\ \text{W}$ when its current coil is connected in the R phase and its pressure coil is connected between this phase and the neutral of a symmetrical 3-phase system supplying a balanced star connected $0.8\ \text{p.f.}$ inductive load. The phase sequence is RYB. What will be the reading of this wattmeter if its pressure coil alone is reconnected between the B and Y phases, all other connections remaining as before?

- (a) 400.0 (b) 519.6
 (c) 300.0 (d) 692.8

81. The inductance of a certain moving-iron ammeter

is expressed as $L = 10 + 3\theta - \frac{\theta^2}{4}\ \mu\text{H}$, where θ is the deflection in radians from the zero position. The control spring torque is $25 \times 10^{-6}\ \text{Nm/radian}$. The deflection of the pointer in radian when the meter carries a current of $5\ \text{A}$, is

- (a) 2.4 (b) 2.0
 (c) 1.2 (d) 1.0

82. A $500\ \text{A}/5\ \text{A}$, $50\ \text{Hz}$ current transformer has a bar primary. The secondary burden is a pure resistance of $1\ \Omega$ and it draws a current of $5\ \text{A}$. If the magnetic core requires $250\ \text{AT}$ for magnetization, the percentage ratio error is

- (a) 10.56 (b) -10.56
 (c) 11.80 (d) -11.80

83. The voltage-flux adjustment of a certain 1-phase $220\ \text{V}$ induction watt-hour meter is altered so that the phase angle between the applied voltage and the flux due to it is 85° (instead of 90°). The errors introduced in the reading of this meter when the current is $5\ \text{A}$ at power factors of unity and 0.5 lagging are respectively

- (a) $3.8\ \text{mW}$, $77.4\ \text{mW}$ (b) $-3.8\ \text{mW}$, $-77.4\ \text{mW}$
 (c) $-4.2\ \text{W}$, $-85.1\ \text{W}$ (d) $4.2\ \text{W}$, $85.1\ \text{W}$

84. Group II represents the figures obtained on a CRO screen when the voltage signals $V_x = V_{xm} \sin \omega t$ and $V_y = V_{ym} \sin(\omega t + \Phi)$ are given to its X and Y plates respectively and Φ is changed. Choose the correct value of Φ from Group I to match with the corresponding figure of Group II

Group I

- P $\Phi = 0$
 Q $\Phi = \pi/2$
 R $\pi < \Phi < 3\pi/2$
 S $\Phi = 3\pi/2$

Group II

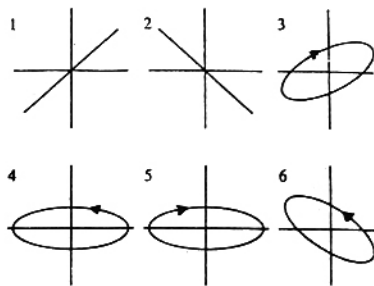

- (a) P = 1, Q = 3, R = 6, S = 5
 (b) P = 2, Q = 6, R = 4, S = 5
 (c) P = 2, Q = 3, R = 5, S = 4
 (d) P = 1, Q = 5, R = 6, S = 6

85. In the circuit shown in Fig. Q85, the current gain (β) of the ideal transistor is 10 . The operating point of the transistor (V_{ce} , I_c) is

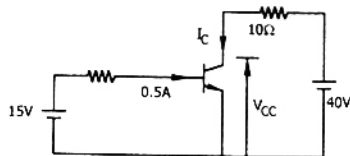

- (a) $(40\ \text{V}, 4\ \text{A})$ (b) $(40\ \text{V}, 5\ \text{A})$
 (c) $(0\ \text{V}, 4\ \text{A})$ (d) $(15\ \text{V}, 4\ \text{A})$

86. A phase-controlled half-controlled single-phase converter is shown in Fig. Q86. The control angle $\alpha = 30^\circ$

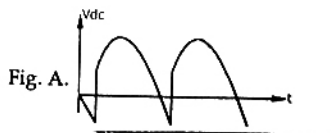
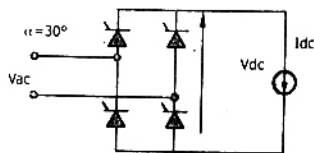

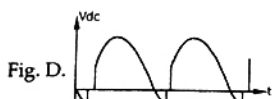
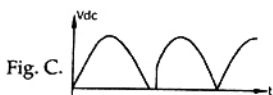
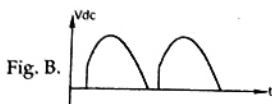

The output dc voltage wshape will be as shown in

- (a) Fig. A (b) Fig. B
(c) Fig. C (d) Fig. D

87. A chopper is employed to charge a battery as shown in Fig.Q87. The charging current is 5 A. The duty ratio is 0.2. The chopper output voltage is also shown in Fig.Q87. The peak to peak ripple current in the charging current is

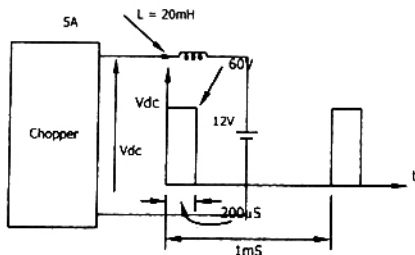

- (a) 0.48 A (b) 1.2 A
(c) 2.4 A (d) 1 A

88. An inverter has a periodic output voltage with the output waveform as shown in Fig.Q88-89.

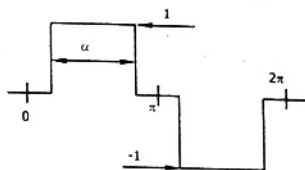

When the conduction angle $\alpha = 120^\circ$, the rms fundamental component of the output voltage is

- (a) 0.78 V (b) 1.10 V
(c) 0.90 V (d) 1.27 V

89. With reference to the output waveform given in Fig.Q88-89, the output of the converter will be free from 5th harmonic when

- (a) $\alpha = 72^\circ$ (b) $\alpha = 36^\circ$
(c) $\alpha = 150^\circ$ (d) $\alpha = 120^\circ$

90. An ac induction motor is used for a speed control application. It is driven from an inverter with a constant V/f control. The motor name-plate details are as follows

V:415 V Ph:3 f:50 Hz N:2850 rpm

The motor is run with the inverter output frequency set at 40 Hz, and with half the rated slip. The running speed of the motor is

- (a) 2400 rpm (b) 2280 rpm
(c) 2340 rpm (d) 2790 rpm

ANSWERS

1. (a) 2. (b) 3. (a) 4. (a) 5. (c) 6. (d) 7. (c) 8. (d) 9. (d) 10. (d)
11. (c) 12. (b) 13. (b) 14. (c) 15. (b) 16. (d) 17. (b) 18. (d) 19. (c) 20. (d)
21. (c) 22. (a) 23. (a) 24. (a) 25. (b) 26. (a) 27. (b) 28. (d) 29. (b) 30. (a)
31. (c) 32. (c) 33. (d) 34. (d) 35. (b) 36. (b) 37. (d) 38. (b) 39. (d) 40. (b)
41. (a) 42. (c) 43. (d) 44. (d) 45. (a) 46. (c) 47. (c) 48. (b) 49. (d) 50. (b)
51. (b) 52. (a) 53. (d) 54. (*) 55. (b) 56. (d) 57. (a) 58. (a) 59. (c) 60. (c)
61. (a) 62. (d) 63. (b) 64. (c) 65. (b) 66. (b) 67. (b) 68. (d) 69. (b) 70. (d)
71. (b) 72. (a) 73. (d) 74. (a) 75. (c) 76. (a) 77. (b) 78. (a) 79. (c) 80. (d)
81. (c) 82. (b) 83. (c) 84. (d) 85. (c) 86. (b) 87. (a) 88. (a) 89. (a) 90. (c)