

GATE : 2008

EE : Electrical Engineering

Duration : Three Hours

Maximum Marks : 150

Read the following instructions carefully

1. Using HB pencil, darken the appropriate bubble under each digit of your registration number and the letters corresponding to your paper code.
2. All the questions in this question paper are of objective type.
3. Questions must be answered on Objective Response Sheet (ORS) by darkening the appropriate bubble (marked A, B, C, D) using HB pencil against the question number on the left hand side of the ORS. **Each question has only one correct answer.** In case you wish to change an answer, erase the old answer completely. More than one answer bubbled against a question will be treated as a wrong answer.
4. Questions 1 through 20 are 1-mark questions and questions 21 through 85 are 2-mark questions.
5. Questions 71 through 73 is one set of common data questions, questions 74 and 75 is another pair of common data questions. The question pairs (76, 77), (78, 79), (80, 81), (82, 83) and (84, 85) are questions with linked answers. The answer to the second question of the above pairs will depend on the answer to the first question of the pair. If the first question in the linked pair is wrongly answered or is un-attempted, then the answer to the second question in the pair will not be evaluated.
6. Un-attempted questions will carry zero marks.
7. **NEGATIVE MARKING:** For Q.1 to Q.20, **0.25** mark will be deducted for each wrong answer. For Q.21 to Q.75, **0.5** mark will be deducted for each wrong answer. For the pairs of questions with linked answers, there will be negative marks only for wrong answer to the first question, i.e; for Q.76, Q.78, Q.80, Q.82 and Q.84, **0.5** mark will be deducted for each wrong answer. There is no negative marking for Q.77, Q.79, Q.81, Q.83 and Q.85.
8. Calculator **without data connectivity** is allowed in the examination hall.
9. Charts, graph sheets and tables are NOT allowed in the examination hall.
10. Rough work can be done on the question paper itself. Additional blank pages are given at the end of the question paper for rough work.

7. A function $y(t)$ satisfies the following differential equation

$$\frac{dy(t)}{dt} + y(t) = \delta(t)$$

Where $\delta(t)$ is the delta function. Assuming zero initial condition, and denoting the unit step function by $u(t)$, $y(t)$ can be of the form

- (a) e^t
 (b) e^{-t}
 (c) $e^t u(t)$
 (d) $e^{-t} u(t)$

8. The equivalent circuits of a diode, during forward biased and reverse biased conditions, are shown in the figure.

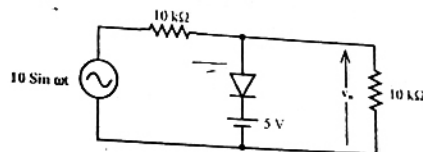
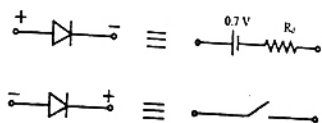

If such a diodes is used in clipper circuit of figure given above, the output voltage (v_o) of the circuit will be

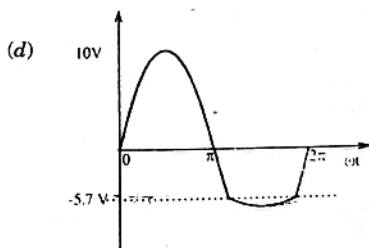
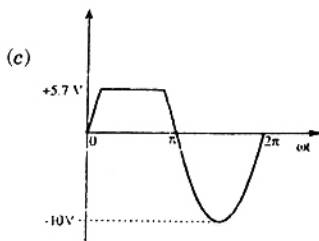
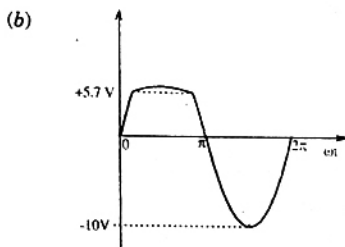
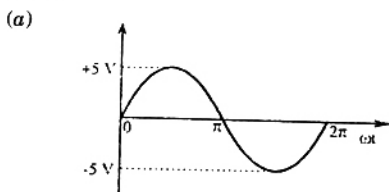

9. Two 8-bit ADCs, one of single slope integrating type and other of successive approximation type, take T_A and T_B times to convert 5 V analog input signal to equivalent digital output. If the input analog signal is reduced to 2.5V, the approximate time taken by the two ADCs will respectively, be

- (a) T_A, T_B
 (b) $\frac{T_A}{2}, T_B$
 (c) $T_A, \frac{T_B}{2}$
 (d) $\frac{T_A}{2}, \frac{T_B}{2}$

10. An input device is interfaced with Intel 8085A microprocessor as memory mapped I/O. The address of the device is 2500H. In order to input data from the device to accumulator, the sequence of instructions will be

- (a) LXI H, 2500H
MOV A, M
- (b) LXI H, 2500H
MOV M, A
- (c) LHLD 2500 H
MOV A, M
- (d) LHLD 2500H
MOV M, A

11. Distributed winding and short chording employed in AC machines will result in
- (a) increase in emf and reduction in harmonics. (b) reduction in emf and increase in harmonics.
- (c) increase in both emf and harmonics. (d) reduction in both emf and harmonics.

12. Three single-phase transformers are connected to form a 3-phase transformer bank. The transformers are connected in the following manner

The transformer connection will be represented by

- (a) Y d0
- (b) Y d1
- (c) Y d6
- (d) Y d11

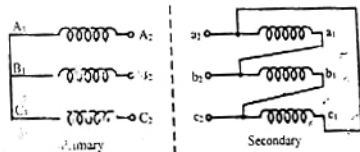

13. In a stepper motor, the detent torque means
- (a) minimum of the static torque with the phase winding excited.
- (b) maximum of the static torque with the phase winding excited.
- (c) minimum of the static torque with the phase winding unexcited.
- (d) maximum of the static torque with the phase winding unexcited.
14. A two machine power system is shown below. Transmission line XY has positive sequence impedance of $Z_1 \Omega$ and zero sequence impedance of $Z_0 \Omega$.

An 'a' phase to ground fault with zero fault impedance occurs at the centre of the transmission line. Bus voltage at X and line current from X to F for the phase 'a', are given by V_a Volts and I_a Amperes, respectively. Then, the impedance measured by the ground distance relay located at the terminal X of line XY will be given by

- (a) $\frac{Z_1}{2} \Omega$
- (b) $\frac{Z_0}{2} \Omega$
- (c) $\frac{(Z_0 + Z_1)}{2} \Omega$
- (d) $\frac{V_a}{I_a} \Omega$

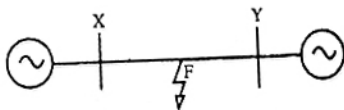

15. An extra high voltage transmission line of length 300 km can be approximated by a lossless line having propagation constant $\beta = 0.00127$ radians per km. Then the percentage ratio of line length to wavelength will be given by

- (a) 24.24% (b) 12.12%
(c) 19.05% (d) 6.06%

16. A 3-phase transmission line is shown in the figure

Voltage drop across the transmission line is given by the following equation

$$\begin{bmatrix} \Delta V_a \\ \Delta V_b \\ \Delta V_c \end{bmatrix} = \begin{bmatrix} Z_s & Z_m & Z_m \\ Z_m & Z_s & Z_m \\ Z_m & Z_m & Z_s \end{bmatrix} \begin{bmatrix} I_a \\ I_b \\ I_c \end{bmatrix}$$

Shunt capacitance of the line can be neglected. If the line has positive sequence impedance of 15Ω and zero sequence impedance of 48Ω , then the values of Z_s and Z_m will be

- (a) $Z_s = 31.5 \Omega$; $Z_m = 16.5 \Omega$
(b) $Z_s = 26 \Omega$; $Z_m = 11 \Omega$
(c) $Z_s = 16.5 \Omega$; $Z_m = 31.5 \Omega$
(d) $Z_s = 11 \Omega$; $Z_m = 26 \Omega$

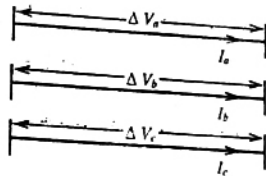

17. In the single phase voltage controller circuit shown in the figure, for what range of triggering angle (α), the output voltage (v_o) is not controllable?

- (a) $0^\circ < \alpha < 45^\circ$
(b) $45^\circ < \alpha < 135^\circ$
(c) $90^\circ < \alpha < 180^\circ$
(d) $135^\circ < \alpha < 180^\circ$

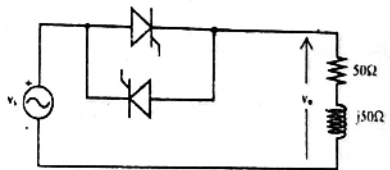

18. A 3-phase Voltage Source Inverter is operated in 180° conduction mode. Which one of the following statements is true?

- (a) Both pole-voltage and line-voltage will have 3^{rd} harmonic components
(b) Pole-voltage will have 3^{rd} harmonic component but line-voltage will be free from 3^{rd} harmonic
(c) Line-voltage will have 3^{rd} harmonic component but pole-voltage will be free from 3^{rd} harmonic
(d) Both pole-voltage and line-voltage will be free from 3^{rd} harmonic components

19. The impulse response of a causal linear time-invariant system is given as $h(t)$. Now consider the following two statements

Statement (I) Principle of superposition holds

Statement (II) $h(t) = 0$ for $t < 0$

Which one of the following statements is correct?

- (a) Statement (I) is correct and Statement (II) is wrong
(b) Statement (II) is correct and Statement (I) is wrong
(c) Both Statement (I) and Statement (II) are wrong
(d) Both Statement (I) and Statement (II) are correct

20. It is desired to measure parameters of $\frac{230 \text{ V}}{115 \text{ V}}$, 2 kVA, single-phase transformer. The following wattmeters are available in a laboratory

W_1 : 250 V, 10 A, Low Power Factor

W_2 : 250 V, 5 A Low Power Factor

W_3 : 150 V, 10 A, High Power Factor

W_4 : 150 V, 5 A, High Power Factor

The wattmeters used in open circuit test and short circuit test of the transformer will respectively be

- (a) W_1 and W_2
 (b) W_2 and W_4
 (c) W_1 and W_4
 (d) W_2 and W_3

Q.21 to Q.75 carry two marks each.

21. The time constant for the given circuit will be

- (a) $\frac{1}{9}$ s
 (b) $\frac{1}{4}$ s
 (c) 4 s
 (d) 9 s

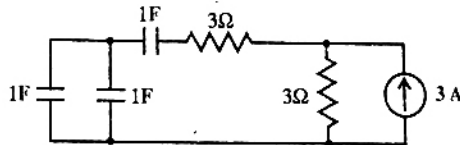

22. The resonant frequency for the given circuit will be

- (a) 1 rad/s
 (b) 2 rad/s
 (c) 3 rad/s
 (d) 4 rad/s

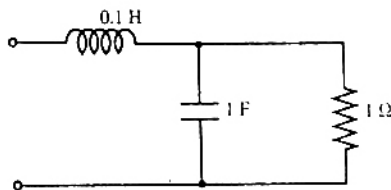

23. Assuming ideal elements in the circuit shown below, the voltage v_{ab} will be

- (a) -3 V
 (b) 0 V
 (c) 3 V
 (d) 5 V

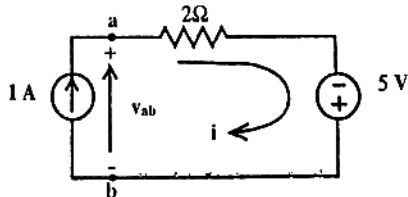

24. A capacitor consists of two metal plates each $500 \times 500 \text{ mm}^2$ and spaced 6 mm apart. The space between the metal plates is filled with a glass plate of 4 mm thickness and a layer of paper of 2 mm thickness. The relative permittivities of the glass and paper are 8 and 2 respectively. Neglecting the fringing effect, the capacitance will be (Given that $\epsilon_0 = 8.85 \times 10^{-12} \text{ F/m}$)
- (a) 983.33 pF
 (b) 1475 pF
 (c) 6637.5 pF
 (d) 9956.25 pF

25. A coil of 300 turns is wound on a non-magnetic core having a mean circumference of 300 mm and a cross-sectional area of 300 mm^2 . The inductance of the coil corresponding to a magnetizing current of 3A will be

(Given that $\mu_0 = 4\pi \times 10^{-7} \text{ H/m}$)

- (a) 37.68 μH (b) 113.04 μH
 (c) 37.68 mH (d) 113.04 mH

26. In the circuit shown in the figure, the value of the current i will be given by

- (a) 0.31 A
 (b) 1.25 A
 (c) 1.75 A
 (d) 2.5 A

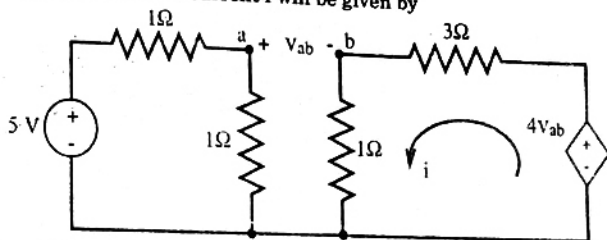

27. Two point charges $Q_1 = 10 \mu\text{C}$ and $Q_2 = 20 \mu\text{C}$ are placed at coordinates $(1, 1, 0)$ and $(-1, -1, 0)$ respectively. The total electric flux passing through a plane $z = 20$ will be

- (a) 7.5 μC (b) 13.5 μC
 (c) 15.0 μC (d) 22.5 μC

28. Given a sequence $x[n]$, to generate the sequence $y[n] = x[3 - 4n]$, which one of the following procedures would be correct?

- (a) First *delay* $x[n]$ by 3 sample to generate $z_1[n]$, then pick every 4th sample of $z_1[n]$ to generate $z_2[n]$, and then finally time reverse $z_2[n]$ to obtain $y[n]$
 (b) First *advance* $x[n]$ by 3 samples to generate $z_1[n]$, then pick every 4th sample of $z_1[n]$ to generate $z_2[n]$, and then finally time reverse $z_2[n]$ to obtain $y[n]$
 (c) First pick every fourth sample of $x[n]$ to generate $v_1[n]$, time-reverse $v_1[n]$ to obtain $v_2[n]$, and finally *advance* $v_2[n]$ by 3 sample to obtain $y[n]$
 (d) First pick every fourth sample of $x[n]$ to generate $v_1[n]$, time-reverse $v_1[n]$ to obtain $v_2[n]$, and finally *delay* $v_2[n]$ by 3 samples to obtain $y[n]$

29. A system with input $x(t)$ and output $y(t)$ is defined by the input-output relation

$$y(t) = \int_{-\infty}^{-2t} x(\tau) d\tau$$

The system will be

- (a) causal, time-invariant and unstable
 (c) non-causal, time-invariant and unstable

- (b) causal, time-invariant and stable
 (d) non-causal, time-variant and unstable

30. A signal $x(t) = \text{sinc}(\alpha t)$ where α is a real constant $\left(\text{sinc}(x) = \frac{\sin(\pi x)}{\pi x}\right)$ is the input to a Linear Time invariant system whose impulse response $h(t) = \text{sinc}(\beta t)$ where β is a real constant. If $\min(\alpha, \beta)$ denotes the minimum of α and β , and similarly $\max(\alpha, \beta)$ denotes the maximum of α and β , and K is a constant, which one of the following statements is true about the **output of the system**?
- (a) It will be of the form $K \sin(\gamma t)$ where $\gamma = \min(\alpha, \beta)$
 (b) It will be of the form $K \text{sinc}(\gamma t)$ where $\gamma = \max(\alpha, \beta)$
 (c) It will be of the form $K \text{sinc}(\alpha t)$
 (d) It cannot be a sinc type of signal
31. Let $x(t)$ be a periodic signal with time period T . Let $y(t) = x(t - t_0) + x(t + t_0)$ for some t_0 . The Fourier Series coefficients of $y(t)$ are denoted by b_k . If $b_k = 0$ for all odd k , then t_0 can be equal to
- (a) $\frac{T}{8}$ (b) $\frac{T}{4}$
 (c) $\frac{T}{2}$ (d) $2T$
32. $H(z)$ is a transfer function of a real system. When a signal $x[n] = (t + j)^n$ is the input to such a system, the output is zero. Further, the region of Convergence (ROC) of $\left(1 - \frac{1}{2}z^{-1}\right) H(z)$ is the entire Z -plane (except $z = 0$). It can then be inferred that $H(z)$ can have a minimum of
- (a) one pole and one zero (b) one pole and two zeros
 (c) two poles and one zero (d) two poles and two zeros
33. Given $X(z) = \frac{z}{(z - a)^2}$ with $|z| > a$, the residue of $X(z)z^{n-1}$ at $z = a$ for $n \geq 0$ will be
- (a) a^{n-1} (b) a^n
 (c) na^n (d) na^{n-1}
34. Consider function $f(x) = (x^2 - 4)^2$ where x is a real number. Then the function has
- (a) only one minimum (b) only two minima
 (c) three minima (d) Three maxima
35. Equation $e^x - 1 = 0$ is required to be solved using Newton's method with an initial guess $x_0 = -1$. Then, after one step of Newton's method, estimate x_1 of the solution will be given by
- (a) 0.71828 (b) 0.36784
 (c) 0.20587 (d) 0.00000
36. A is a $m \times n$ full rank matrix with $m > n$ and I is an identity matrix. Let matrix $A^* = (A^T A)^{-1} A^T$. Then, which one of the following statements is FALSE?
- (a) $AA^*A = A$ (b) $(AA^*)^2 = AA^*$
 (c) $A^*A = I$ (d) $AA^*A = A^*$

37. A differential equation $\frac{dx}{dt} = e^{-2t} u(t)$ has to be solved using trapezoidal rule of integration with a step size $h = 0.01$ s. Function $u(t)$ indicates a unit step function. If $x(0^-) = 0$, then value of x at $t = 0.01$ s will be given by

- (a) 0.00099 (b) 0.00495
(c) 0.0099 (d) 0.0198

38. Let P be a 2×2 real orthogonal matrix and \vec{x} is a real vector $[x_1, x_2]^T$ with length $\|\vec{x}\| = (x_1^2 + x_2^2)^{\frac{1}{2}}$.

Then, which one of the following statements is correct?

- (a) $\|P\vec{x}\| \leq \|\vec{x}\|$ where at least one vector satisfies $\|P\vec{x}\| < \|\vec{x}\|$
(b) $\|P\vec{x}\| = \|\vec{x}\|$ for all vectors \vec{x}
(c) $\|P\vec{x}\| \geq \|\vec{x}\|$ where at least one vector satisfies $\|P\vec{x}\| > \|\vec{x}\|$
(d) No relationship can be established between $\|\vec{x}\|$ and $\|P\vec{x}\|$

39. Let $x(t) = \text{rect}\left(t - \frac{1}{2}\right)$ (where $\text{rect}(x) = 1$ for $-\frac{1}{2} \leq x \leq \frac{1}{2}$ and zero otherwise). Then if since

$(x) = \frac{\sin(\pi x)}{\pi x}$, the Fourier Transform of $x(t) + x(-t)$ will be given by

- (a) $\text{sinc}\left(\frac{\omega}{2\pi}\right)$ (b) $2 \text{sinc}\left(\frac{\omega}{2\pi}\right)$
(c) $2 \text{sinc}\left(\frac{\omega}{2\pi}\right) \cos\left(\frac{\omega}{2}\right)$ (d) $\text{sinc}\left(\frac{\omega}{2\pi}\right) \sin\left(\frac{\omega}{2}\right)$

40. Two perfectly matched silicon transistors are connected as shown in the figure. Assuming the β of the transistors to be very high and the forward voltage drop in diodes to be 0.7 V, the value of current I is

- (a) 0 mA
(b) 3.6 mA
(c) 4.3 mA
(d) 5.7 mA

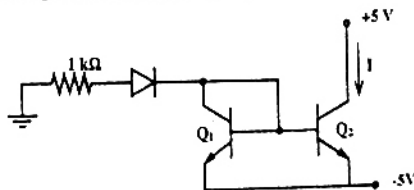

41. In the voltage doubler circuit shown in the figure, the switch 'S' is closed at $t = 0$. Assuming diodes D_1 and D_2 to be ideal, load resistance to be infinite and initial capacitor voltages to be zero, the steady state voltage across capacitors C_1 and C_2 will be

- (a) $v_{c1} = 10V, v_{c2} = 5V$
(b) $v_{c1} = 10V, v_{c2} = -5V$
(c) $v_{c1} = 5V, v_{c2} = 10V$
(d) $v_{c1} = 5V, v_{c2} = -10V$

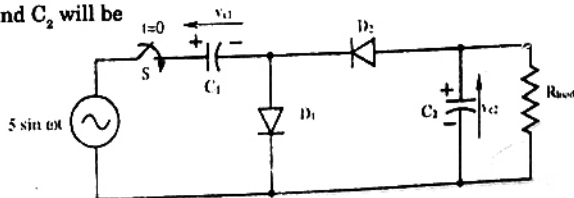

42. The block diagrams of two types of half wave rectifiers are shown in the figure. The transfer characteristics of the rectifiers are also shown within the block.

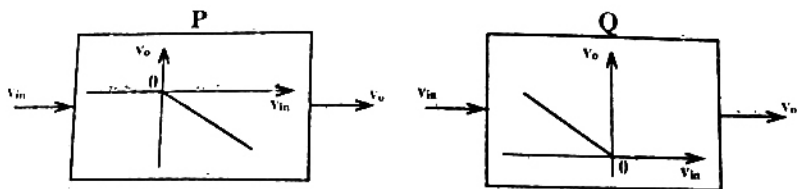

It is desired to make full wave rectifier using above two half-wave rectifiers. The resultant circuit will be

(a)

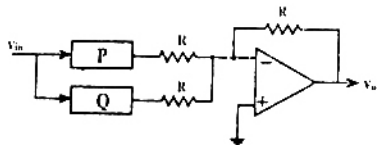

(b)

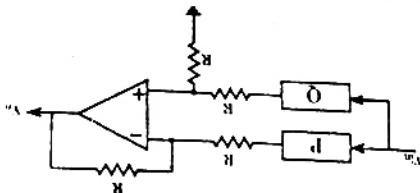

(c)

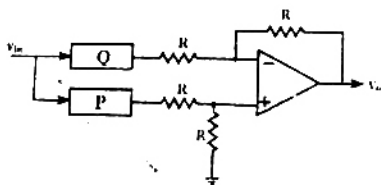

(d)

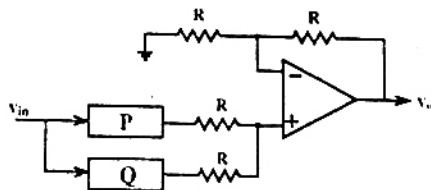

43. A 3 line to 8 line decoder, with active low outputs, is used to implement a 3- variable Boolean function as shown in the figure.

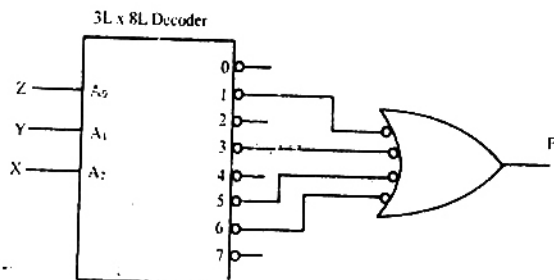

The simplified form of Boolean function $F(A, B, C)$ implemented in 'Product of Sum' form will be

- (a) $(X + Z). (\bar{X} + \bar{Y} + \bar{Z}). (Y + Z)$
 (b) $(\bar{X} + \bar{Z}). (X + Y + Z). (\bar{Y} + \bar{Z})$
 (c) $(\bar{X} + \bar{Y} + Z). (\bar{X} + Y + Z). (X + \bar{Y} + Z). (X + Y + \bar{Z})$
 (d) $(\bar{X} + \bar{Y} + \bar{Z}). (\bar{X} + Y + \bar{Z}). (X + Y + Z). (X + \bar{Y} + \bar{Z})$

44. The truth table of a monoshot shown in the figure is given in the table below

X	Y	Q	\bar{Q}
0	↑		
	↓		

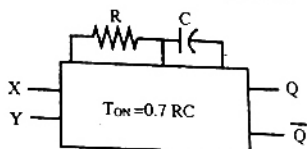

Two monoshots, one positive edge triggered and other negative edge triggered, are connected as shown in the figure. The pulse widths of the two monoshot outputs, Q_1 and Q_2 , are T_{ON_1} and T_{ON_2} respectively.

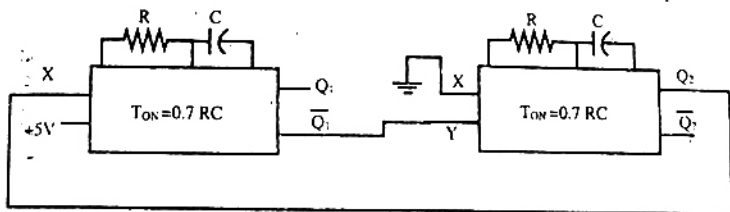

The frequency and the duty cycle of the signal at Q_1 will respectively be

(a) $f = \frac{1}{T_{ON_1} + T_{ON_2}}$, $D = \frac{1}{5}$

(b) $f = \frac{1}{T_{ON_1} + T_{ON_2}}$, $D = \frac{T_{ON_2}}{T_{ON_1} + T_{ON_2}}$

(c) $f = \frac{1}{T_{ON_1}}$, $D = \frac{T_{ON_1}}{T_{ON_1} + T_{ON_2}}$

(d) $f = \frac{1}{T_{ON_2}}$, $D = \frac{T_{ON_1}}{T_{ON_1} + T_{ON_2}}$

45. The contents (in Hexadecimal) of some of the memory locations in an 8085A based system are given below

Address	Contents
..	..
26FE	00
26FF	01
2700	02
2701	03
2702	04
..	..

The contents of stack pointer (SP), program counter (PC) and (H, L) are 2700H, 2100H and 0000H respectively. When the following sequence of instructions are executed,

2100 H: DAD SP

2101 H: PCHL

the contents of (SP) and (PC) at the end of execution will be

(a) (PC) = 2102H, (SP) = 2700H

(b) (PC) = 2700H, (SP) = 2700H

(c) (PC) = 2800H, (SP) = 26 FEH

(d) (PC) = 2A02H, (SP) = 2702H

46. A waveform generator circuit using OPAMPs is shown in the figure. It produces a triangular wave at point 'P' with a peak to peak voltage of 5 V for $v_1 = 0$ V.

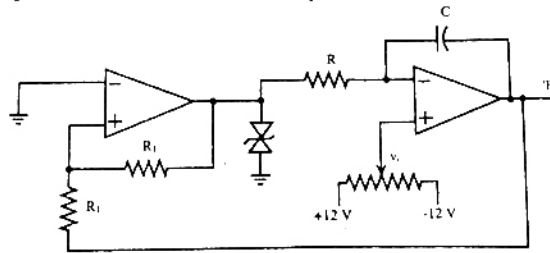

If the voltage v_1 is made + 2.5 V, the voltage waveform at point 'P' will become

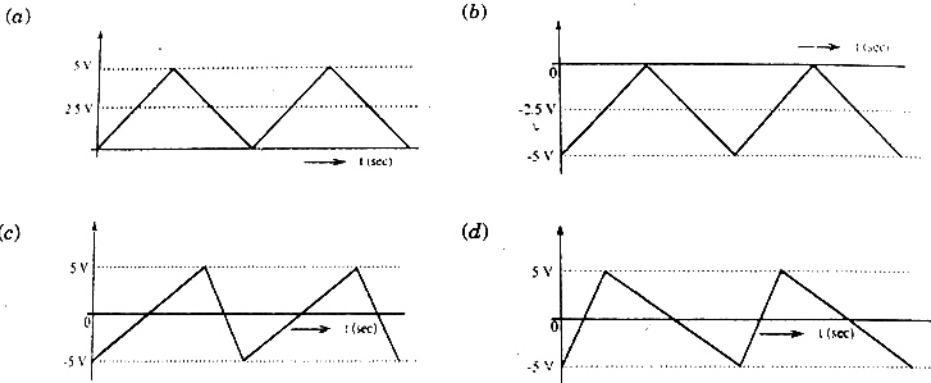

47. A 230 V, 50 Hz, 4-pole, single-phase induction motor is rotating in the clockwise (forward) direction at a speed of 1425 -rpm. If the rotor resistance at standstill is 7.8 Ω . then the effective rotor resistance in the backward branch of the equivalent circuit will be

- (a) 2 Ω (b) 4 Ω
(c) 78 Ω (d) 156 Ω

48. A 400 V, 50 Hz, 30 hp, three-phase induction motor is drawing 50 A current at 0.8 power factor lagging. The stator and rotor copper losses are 1.5 kW and 900 W respectively. The friction and windage losses are 1050 W and the core losses are 1200 W. The air-gap power of the motor will be

- (a) 23.06 kW (b) 24.11 kW
(c) 25.01 kW (d) 26.21 kW

49. The core of a two-winding transformer is subjected to a magnetic flux variation as indicated in the figure.

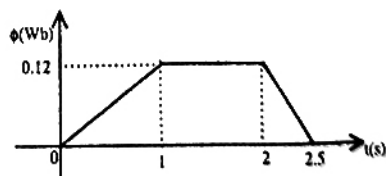
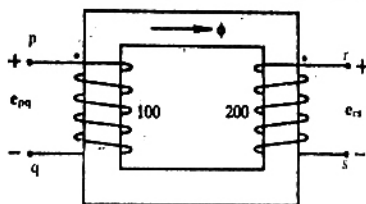

The induced emf (e_m) in the secondary winding as a function of time will be of the form

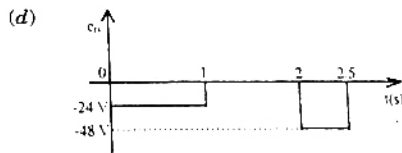
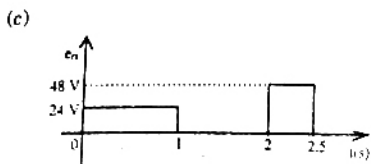
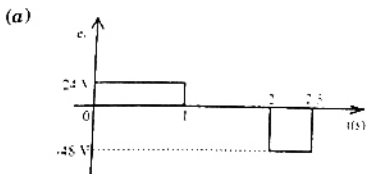

50. Voltage phasors at the two terminals of a transmission line of length 70 km have a magnitude of 1.0 per unit but are 180 degrees out of phase. Assuming that the maximum load current in the line is $\frac{1}{5}$ th of minimum 3-phase fault current, which one of the following transmission line protection schemes will NOT pick up for this condition?

- (a) Distance protection using mho relays with zone-1 set to 80% of the line impedance
 (b) Directional overcurrent protection set to pick up at 1.25 times the maximum load current
 (c) Pilot relaying system with directional comparison scheme
 (d) Pilot relaying system with segregated phase comparison scheme

51. A lossless transmission line having Surge Impedance Loading (SIL) of 2280 MW is provided with a uniformly distributed series capacitive compensation of 30%. Then, SIL of the compensated transmission line will be

- (a) 1835 MW
 (b) 2280 MW
 (c) 2725 MW
 (d) 3257 MW

52. A lossless power system has to serve a load of 250 MW. There are two generators (G_1 and G_2) in the system with cost curves C_1 and C_2 respectively defined as follows

$$C_1(P_{G1}) = P_{G1} + 0.055 \times P_{G1}^2$$

$$C_2(P_{G2}) = 3P_{G2} + 0.03 \times P_{G2}^2$$

where P_{G1} and P_{G2} are the MW injections from generator G_1 and G_2 respectively. Then the minimum cost dispatch will be

- (a) $P_{G1} = 250$ MW; $P_{G2} = 0$ MW
 (b) $P_{G1} = 150$ MW; $P_{G2} = 100$ MW
 (c) $P_{G1} = 100$ MW; $P_{G2} = 150$ MW
 (d) $P_{G1} = 0$ MW; $P_{G2} = 250$ MW

53. A lossless single machine infinite bus power system is shown below

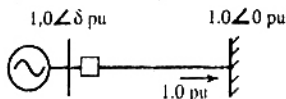

The synchronous generator transfers 1.0 per unit of power to the infinite bus. Critical clearing time of circuit breaker is 0.28 s. If another identical synchronous generator is connected in parallel to the existing generator and each generator is scheduled to supply 0.5 per unit of power. Then the critical clearing time of the circuit breaker will

- (a) reduce to 0.14 s
- (b) reduce but will be more than 0.14 s
- (c) remain constant at 0.28 s
- (d) increase beyond 0.28 s

54. Single line diagram of a 4-bus single source distribution system is shown below. Branches e_1 , e_2 , e_3 and e_4 have equal impedances. The load current values indicated in the figure are in per unit.

Distribution company's policy requires radial system operation with minimum loss. This can be achieved by opening of the branch

- (a) e_1
- (b) e_2
- (c) e_3
- (d) e_4

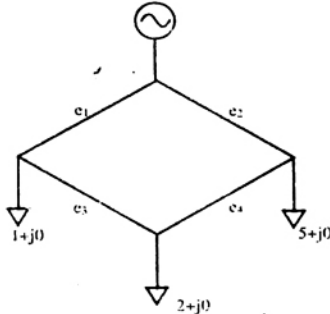

55. A single phase fully controlled bridge converter supplies a load drawing constant and ripple free load current. If the triggering angle is 30° , the input power factor will be

- (a) 0.65
- (b) 0.78
- (c) 0.85
- (d) 0.866

56. A single-phase half controlled converter shown in the figure is feeding power to highly inductive load. The converter is operating at a firing angle of 60° .

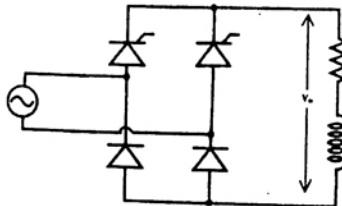

If the firing pulses are suddenly removed, the steady state voltage (v_o) waveform of the converter will become

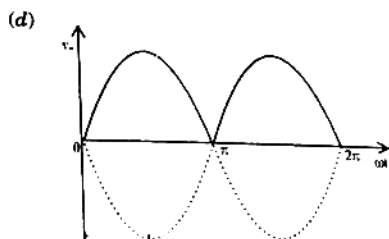
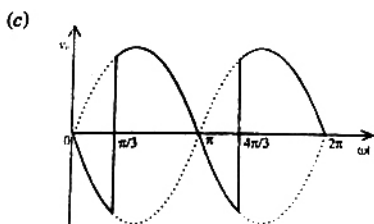
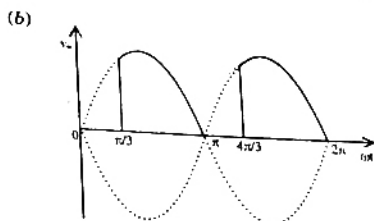
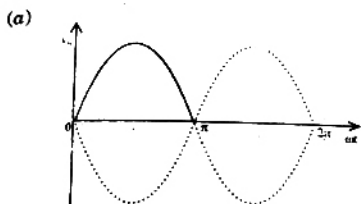

57. A 220 V, 20 A, 1000 rpm, separately excited dc motor has an armature resistance of 2.5Ω . The motor is controlled by a step down chopper with a frequency of 1 kHz. The input dc voltage to the chopper is 250 V. The duty cycle of the chopper for the motor to operate at a speed of 600 rpm delivering the rated torque will be

(a) 0.518

(b) 0.608

(c) 0.852

(d) 0.902

58. A 220 V, 1400 rpm, 40 A separately excited dc motor has an armature resistance of 0.4Ω . The motor is fed from a single phase circulating current dual converter with an input ac line voltage of 220 V (rms). The approximate firing angles of the dual converter for motoring operation at 50% of rated torque and 1000 rpm will be

(a) $43^\circ, 137^\circ$

(b) $43^\circ, 47^\circ$

(c) $39^\circ, 141^\circ$

(d) $39^\circ, 51^\circ$

59. A single phase voltage source inverter is feeding a purely inductive load as shown in the figure.

The inverter is operated at 50 Hz in 180° square wave mode. Assume that the load current does not have any dc component. The peak value of the inductor current i_o will be

(a) 6.37 A

(b) 10 A

(c) 20 A

(d) 40 A

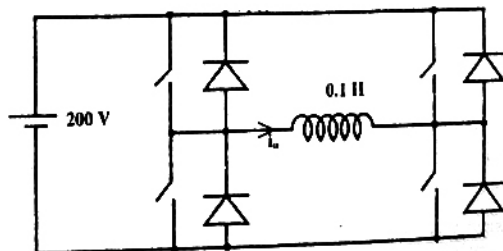

60. A 400 V, 50 Hz, 4 pole, 1400 rpm, star connected squirrel cage induction motor has the following parameters referred to the stator

$$R_s' = 1.0 \Omega, X_s = X_s' = 1.5 \Omega$$

Neglect stator resistance and core and rotational losses of the motor.

The motor is controlled from a 3-phase voltage source inverter with constant V/f control. The stator line-to-line voltage (rms) and frequency to obtain the maximum torque at starting will be

- (a) 20.6 V, 2.7 Hz
 (b) 133.3 V, 16.7 Hz
 (c) 266.6 V, 33.3 Hz
 (d) 323.3 V, 40.3 Hz
61. A single phase fully controlled converter bridge is used for electrical braking of a separately excited dc motor. The dc motor load is represented by an equivalent circuit as shown in the figure. Assume that the load inductance is sufficient to ensure continuous and ripple free load current. The firing angle of the bridge for a load current of $I_o = 10$ A will be

- (a) 44°
 (b) 51°
 (c) 129°
 (d) 136°

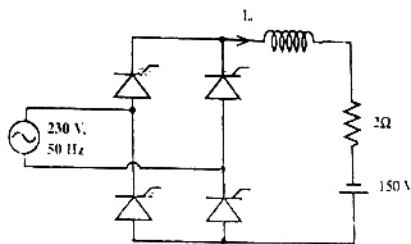

62. A three phase fully controlled bridge converter is feeding a load drawing a constant and ripple free load current of 10 A at a firing angle of 30°. The approximate Total Harmonic Distortion (%THD) and the rms value of fundamental component of the input current will respectively be

- (a) 31% and 6.8 A
 (b) 31% and 7.8 A
 (c) 66% and 6.8 A
 (d) 66% and 7.8 A

63. In the circuit shown in the figure, the switch is operated at a duty cycle of 0.5. A large capacitor is connected across the load. The inductor current is assumed to be continuous.

The average voltage across the load and the average current through the diode will respectively be

- (a) 10 V, 2 A
 (b) 10 V, 8 A
 (c) 40 V, 2 A
 (d) 40 V, 8 A

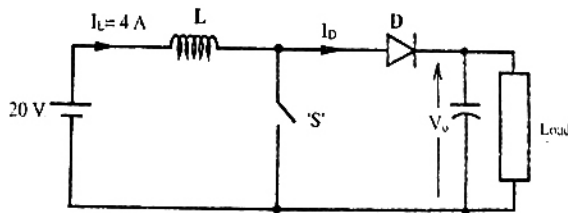

64. The transfer function of a linear time invariant system is given as

$$G(s) = \frac{1}{s^2 + 3s + 2}$$

The steady state value of the output of this system for a unit impulse input applied at time instant $t = 1$ will be

- (a) 0
 (b) 0.5
 (c) 1
 (d) 2

65. The transfer functions of two compensators are given below

$$C_1 = \frac{10(s+1)}{(s+10)}, C_2 = \frac{s+10}{10(s+1)}$$

Which one of the following statements is correct?

- (a) C_1 is a lead compensator and C_2 is a lag compensator
 (b) C_1 is a lag compensator and C_2 is a lead compensator
 (c) Both C_1 and C_2 are lead compensators
 (d) Both C_1 and C_2 are lag compensators
66. The asymptotic Bode magnitude plot of a minimum phase transfer function is shown in the figure. This transfer function has

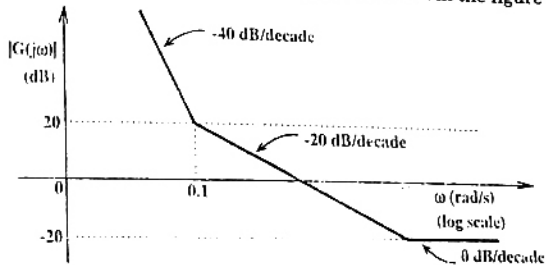

- (a) Three poles and one zero
 (b) Two poles and one zero
 (c) Two poles and two zeros
 (d) One pole and two zeros

67. Figure shows a feedback system where $K > 0$.

The range of K for which the system is stable will be given by

- (a) $0 < K < 30$
 (b) $0 < K < 39$
 (c) $0 < K < 390$
 (d) $K > 390$

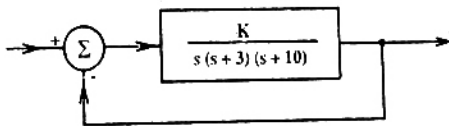

68. The transfer function of a system is given as $\frac{100}{s^2 + 20s + 100}$. This system is

- (a) an overdamped system
 (b) an underdamped system
 (c) a critically damped system
 (d) an unstable system

69. Two sinusoidal signals $p(\omega_1 t) = A \sin \omega_1 t$ and $q(\omega_2 t)$ are applied to X and Y inputs of a dual channel CRO. The Lissajous figure displayed on the screen is shown below

The signal $q(\omega_2 t)$ will be represented as

- (a) $q(\omega_2 t) = A \sin \omega_2 t, \omega_2 = 2\omega_1$
 (b) $q(\omega_2 t) = A \sin \omega_2 t, \omega_2 = \frac{\omega_1}{2}$
 (c) $q(\omega_2 t) = A \cos \omega_2 t, \omega_2 = 2\omega_1$
 (d) $q(\omega_2 t) = A \cos \omega_2 t, \omega_2 = \frac{\omega_1}{2}$

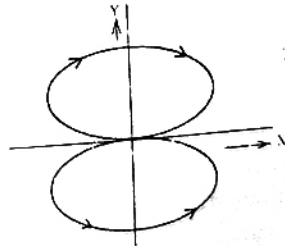

70. The ac bridge shown in the figure is used to measure the impedance Z .
If the bridge is balanced for oscillator frequency $f = 2 \text{ kHz}$, then the impedance Z will be

- (a) $(260 + j0) \Omega$
 (b) $(0 + j200) \Omega$
 (c) $(260 - j200) \Omega$
 (d) $(260 + j200) \Omega$

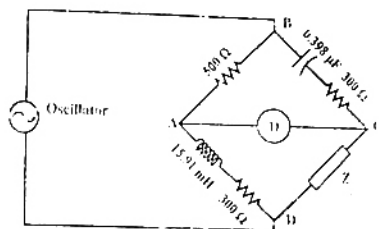

Common Data Questions

Common Data for Questions 71, 72 and 73:

Consider a power system shown below:

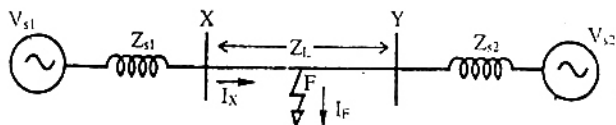

Given that:

$$V_{s1} = V_{s2} = 1.0 + j0.0 \text{ pu};$$

The positive sequence impedance are $Z_{s1} = Z_{s2} = 0.001 + j0.01 \text{ pu}$ and $Z_L = 0.006 + j0.06 \text{ pu}$.

3-phase Base MVA = 100

Voltage base = 400 kV (Line to Line)

Nominal system frequency = 50 Hz

The reference voltage for phase 'a' is defined as $v(t) = V_m \cos(\omega t)$.

A symmetrical three phase fault occurs at centre of the line, i.e. point 'F' at time t_0 . The positive sequence impedance from source S_1 to point 'F' equals $0.004 + j0.04 \text{ pu}$. The waveform corresponding to phase 'a' fault current from bus X reveals that decaying dc offset current is negative and in magnitude at its maximum initial value. Assume that the negative sequence impedances are equal to positive sequence impedances, and the zero sequence impedances are three times positive sequence impedances.

71. The instant (t_0) of the fault will be
- (a) 4.682 ms
 (b) 9.667 ms
 (c) 14.667 ms
 (d) 19.667 ms
72. The rms value of the ac component of fault current (I_f) will be
- (a) 3.59 kA
 (b) 5.07 kA
 (c) 7.18 kA
 (d) 10.15 kA
73. Instead of the three phase fault, if a single line to ground fault occurs on phase 'a' at point 'F' with zero fault impedance, then the rms value of the ac component of fault current (I_f) for phase 'a' will be
- (a) 4.97 pu
 (b) 7.0 pu
 (c) 14.93 pu
 (d) 29.85 pu

Common Data for Questions 74 and 75:

A 3-phase, 440 V, 50 Hz, 4-pole, slip ring induction motor is fed from the rotor side through an auto-transformer and the stator is connected to a variable resistance as shown in the figure.

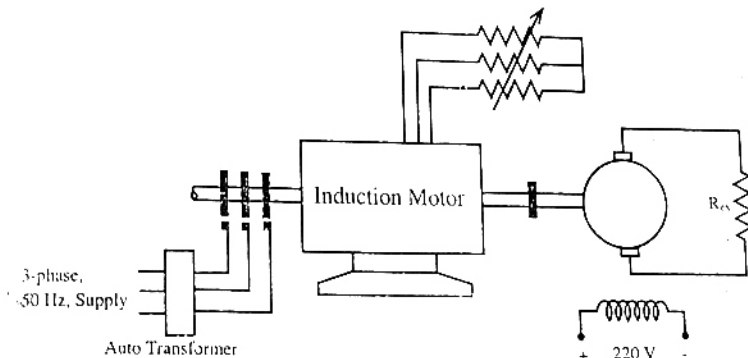

The motor is coupled to a 220 V, separately excited, dc generator feeding power to fixed resistance of 10Ω . Two-wattmeter method is used to measure the input power to induction motor. The variable resistance is adjusted such that the motor runs at 1410 rpm and the following readings were recorded $W_1 = 1800 \text{ W}$, $W_2 = -200 \text{ W}$

74. The speed of rotation of stator magnetic field with respect to rotor structure will be
- (a) 90 rpm in the direction of rotation. (b) 90 rpm in the opposite direction of rotation.
 (c) 1500 rpm in the direction of rotation (d) 1500 rpm in the opposite direction of rotation
75. Neglecting all losses of both the machines, the dc generator power output and the current through resistance (R_{ex}) will respectively be
- (a) 96 W, 3.10 A (b) 120 W, 3.46 A
 (c) 1504 W, 12.26 A (d) 1880 W, 13.71 A

Linked Answer Questions: Q.76 to Q.85 carry two marks each.

Statement for Linked Answer Questions 76 and 77:

The current $i(t)$ sketched in the figure flows through an initially uncharged 0.3 nF capacitor.

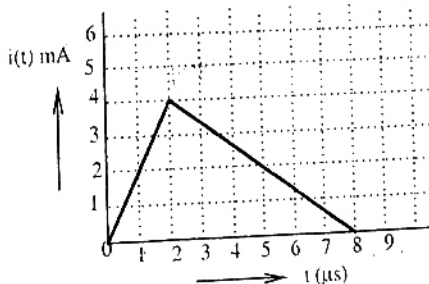

76. The charge stored in the capacitor at $t = 5 \mu\text{s}$, will be
- (a) 8 nC (b) 10 nC
 (c) 13 nC (d) 16 nC

77. The capacitor charged upto $5 \mu\text{s}$, as per the current profile given in the figure, is connected across an inductor of 0.6 mH . Then the value of voltage across the capacitor after $1 \mu\text{s}$ will approximately be
- (a) 18.8 V (b) 23.5 V
 (c) -23.5 V (d) -30.6 V

Statement for Linked Answer Questions 78 and 79:

The state space equation of a system is described by

$$\dot{x} = Ax + Bu$$

$$y = Cx$$

where x is state vector, u is input, y is output and $A = \begin{bmatrix} 0 & 1 \\ 0 & -2 \end{bmatrix}$, $B = \begin{bmatrix} 0 \\ 1 \end{bmatrix}$, $C = [1 \ 0]$.

78. The transfer function $G(s)$ of this system will be

(a) $\frac{s}{(s+2)}$

(b) $\frac{s+1}{s(s-2)}$

(c) $\frac{s}{(s-2)}$

(d) $\frac{1}{s(s+2)}$

79. A unity feedback is provided to the above system $G(s)$ to make it a closed loop system as shown in figure. For a unit step input $r(t)$, the steady state error in the output will be

(a) 0

(b) 1

(c) 2

(d) ∞

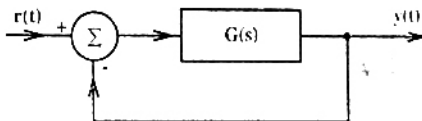

Statement for Linked Answer Questions 80 and 81:

A general filter circuit is shown in the figure:

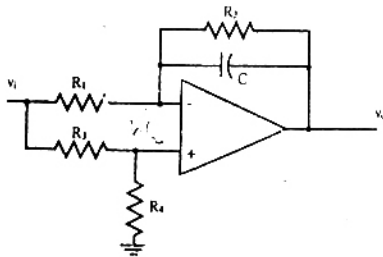

80. If $R_1 = R_2 = R_A$ and $R_3 = R_4 = R_B$, the circuit acts as a

(a) all pass filter

(b) band pass filter

(c) high pass filter

(d) low pass filter

81. The output of the filter in Q.80 is given to the circuit shown in figure

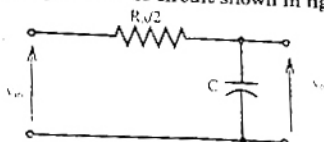

The gain vs frequency characteristic of the output (v_o) will be

(a)

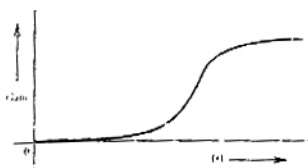

(b)

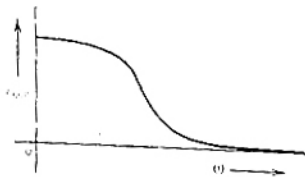

(c)

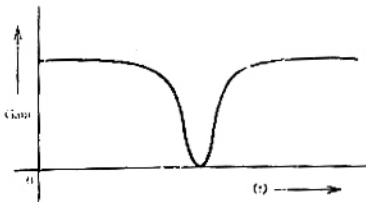

(d)

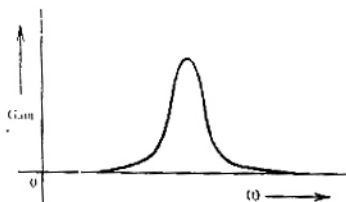

Statement for Linked Answer Questions 82 and 83:

A 240 V, dc shunt motor draws 15 A while supplying the rated load at a speed of 80 rad/s. The armature resistance is 0.5Ω and the field winding resistance is 80Ω .

82. The net voltage across the armature resistance at the time of plugging will be

(a) 6 V

(b) 234 V

(c) 240 V

(d) 474 V

83. The external resistance to be added in the armature circuit to limit the armature current to 125% of its rated value is

(a) 31.1Ω

(b) 31.9Ω

(c) 15.1Ω

(d) 15.9Ω

Statement for Linked Answer Questions 84 and 85:

A synchronous motor is connected to an infinite bus at 1.0 pu voltage and draws 0.6 pu current at unity power factor. Its synchronous reactance is 1.0 pu and resistance is negligible.

84. The excitation voltage (E) and load angle (δ) will respectively be

(a) 0.8 pu and 36.86° lag

(b) 0.8 pu and 36.86° lead

(c) 1.17 pu and 30.96° lead

(d) 1.17 pu and 30.96° lag

85. Keeping the excitation voltage same, the load on the motor is increased such that the motor current increases by 20%. The operating power factor will become

(a) 0.995 lagging

(b) 0.995 leading

(c) 0.791 lagging

(d) 0.848 leading

ANSWERS

- | | | | | | | | | | |
|---------|---------|---------|---------|---------|---------|---------|---------|---------|---------|
| 1. (a) | 2. (b) | 3. (a) | 4. (c) | 5. (d) | 6. (a) | 7. (d) | 8. (a) | 9. (a) | 10. (a) |
| 11. (d) | 12. (b) | 13. (c) | 14. (d) | 15. (d) | 16. (b) | 17. (a) | 18. (b) | 19. (d) | 20. (d) |
| 21. (c) | 22. (c) | 23. (a) | 24. (b) | 25. (b) | 26. (b) | 27. (c) | 28. (d) | 29. (d) | 30. (a) |
| 31. (b) | 32. (b) | 33. (d) | 34. (b) | 35. (a) | 36. (d) | 37. (c) | 38. (b) | 39. (c) | 40. (c) |
| 41. (d) | 42. (b) | 43. (b) | 44. (b) | 45. (b) | 46. (a) | 47. (b) | 48. (c) | 49. (b) | 50. (a) |
| 51. (b) | 52. (c) | 53. (b) | 54. (d) | 55. (b) | 56. (b) | 57. (b) | 58. (c) | 59. (b) | 60. (b) |
| 61. (c) | 62. (b) | 63. (a) | 64. (b) | 65. (a) | 66. (c) | 67. (c) | 68. (c) | 69. (d) | 70. (a) |
| 71. (*) | 72. (*) | 73. (*) | 74. (a) | 75. (c) | 76. (c) | 77. (c) | 78. (d) | 79. (a) | 80. (c) |
| 81. (d) | 82. (d) | 83. (a) | 84. (c) | 85. (d) | | | | | |

EXPLANATIONS

1. Network Graph of given circuit is

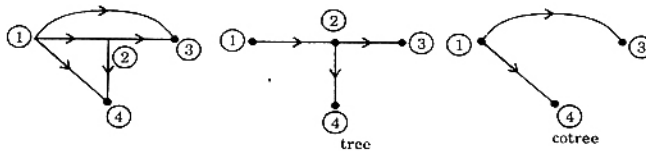

∴ Number of chords = branches of tree = 2

Since there is no option which has answer 2, so closest answer is 3. Hence option (a) is correct.

Alternately

Opening up current source and short-circuiting voltage source, we have the graph as follows,

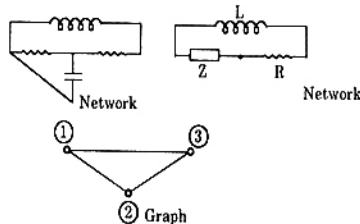

2. Since Thevenin's impedance, $Z_0 = 2.38 - j 0.667 \Omega$

Z_0 is a combination of resistor and capacitor in series

For Minimum realization,

$$Z_0 = R + \frac{1}{Cs} = R + \frac{1}{j\omega C}$$

$$= R - \frac{j}{\omega S}$$

So Z_0 will have a resistor and a capacitor.