

GATE CS - 1994

Read the following instructions carefully:

- (i) This question paper consists of two sections: A & B.
- (ii) Section A has EIGHT questions. Answer all questions in this section.
- (iii) Section B has TWENTY questions. Answer any TEN questions in this section.
- (iv) Begin answer for this section on a fresh page.
- (v) Answer to questions in each section should appear together in the same sequence in which they appear in the question paper.
- (vi) There will be no negative marking.

Section – A

1. Choose one of the alternatives for the following questions:

- 1.1 FORTRAN implementation do not permit recursion because
- (a) they use static allocation for variables
 - (b) they use dynamic allocation for variables
 - (c) stacks are not available on all machines
 - (d) it is not possible to implement recursion on all machines
- 1.2 Let A and B be real symmetric matrices of size $n \times n$. Then which one of the following is true?
- (a) $AA' = 1$ (b) $A = A^{-1}$ (c) $AB = BA$ (d) $(AB)' = BA$
- 1.3 Backward Euler method for solving the differential equation $\frac{dy}{dx} = f(x, y)$ is specified by, (choose one of the following).
- (a) $y_{n+1} = y_n + hf(x_n, y_n)$ (b) $y_{n+1} = y_n + hf(x_{n+1}, y_{n+1})$
(c) $y_{n+1} = y_{n-1} + 2hf(x_n, y_n)$ (d) $y_{n+1} = (1 + h)f(x_{n+1}, y_{n+1})$
- 1.4 Let A and B be any two arbitrary events, then, which one of the following is true?
- (a) $P(A \cap B) = P(A)P(B)$ (b) $P(A \cup B) = P(A) + P(B)$
(c) $P(A|B) = P(A \cap B)P(B)$ (d) $P(A \cup B) \leq P(A) + P(B)$
- 1.5 An unrestricted use of the "goto" statement is harmful because
- (a) it makes it more difficult to verify programs
 - (b) it increases the running time of the programs
 - (c) it increases the memory required for the programs
 - (d) it results in the compiler generating longer machine code

1.6 The number of distinct simple graphs with upto three nodes is
 (a) 15 (b) 10 (c) 7 (d) 9

1.7 The recurrence relation that arises in relation with the complexity of binary search is:

- (a) $T(n) = T\left(\frac{n}{2}\right) + k$, k a constant (b) $T(n) = 2T\left(\frac{n}{2}\right) + k$, k a constant
 (c) $T(n) = T\left(\frac{n}{2}\right) + \log n$ (d) $T(n) = T\left(\frac{n}{2}\right) + n$

1.8 The logic expression for the output of the circuit shown in figure below is:

- (a) $\overline{AC} + \overline{BC} + CD$
 (b) $A\overline{C} + B\overline{C} + \overline{C}D$
 (c) $ABC = \overline{C}D$
 (d) $\overline{A} \overline{B} + \overline{B} \overline{C} + \overline{C} \overline{D}$

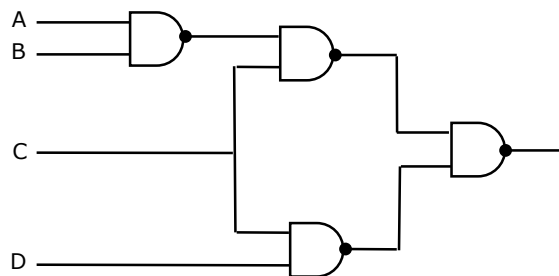

1.9 The rank of matrix $\begin{bmatrix} 0 & 0 & -3 \\ 9 & 3 & 5 \\ 3 & 1 & 1 \end{bmatrix}$ is:

- (a) 0 (b) 1 (c) 2 (d) 3

1.10 Some group (G, o) is known to be abelian. Then, which one of the following is true for G?

- (a) $g = g^{-1}$ for every $g \in G$ (b) $g = g^2$ for every $g \in G$
 (c) $(goh)^2 = g^2oh^2$ for every $g, h \in G$ (d) G is of finite order

1.11 In a compact single dimensional array representation for lower triangular matrices (i.e all the elements above the diagonal are zero) of size $n \times n$, non-zero elements (i.e elements of the lower triangle) of each row are stored one after another, starting from the first row, the index of the $(i, j)^{th}$ element of the lower triangular matrix in this new representation is:

- (a) $i + j$ (b) $i + j - 1$ (c) $j + \frac{i(i-1)}{2}$ (d) $i + \frac{j(j-1)}{2}$

1.12 Generation of intermediate code based on an abstract machine model is useful in compilers because

- (a) it makes implementation of lexical analysis and syntax analysis easier

- (b) syntax-directed translations can be written for intermediate code generation
 - (c) it enhances the portability of the front end of the compiler
 - (d) it is not possible to generate code for real machines directly from high level language programs
- 1.13 A memory page containing a heavily used variable that was initialized very early and is in constant use is removed when
- (a) LRU page replacement algorithm is used
 - (b) FIFO page replacement algorithm is used
 - (c) LFU page replacement algorithm is used
 - (d) None of the above
- 1.14 Which of the following permutations can be obtained in the output (in the same order) using a stack assuming that the input is the sequence 1, 2, 3, 4, 5 in that order?
- (a) 3, 4, 5, 1, 2
 - (b) 3, 4, 5, 2, 1
 - (c) 1, 5, 2, 3, 4
 - (d) 5, 4, 3, 1, 2
- 1.15 The number of substrings (of all lengths inclusive) that can be formed from a character string of length n is
- (a) n
 - (b) n^2
 - (c) $\frac{n(n-1)}{2}$
 - (d) $\frac{n(n+1)}{2}$
- 1.16 Which of the following conversions is not possible (algorithmically)?
- (a) Regular grammar to context free grammar
 - (b) Non-deterministic FSA to deterministic FSA
 - (c) Non-deterministic PDA to deterministic PDA
 - (d) Non-deterministic Turing machine to deterministic Turing machine
- 1.17 Linked lists are not suitable data structures of which one of the following problems?
- (a) Insertion sort
 - (b) Binary search
 - (c) Radix sort
 - (d) Polynomial manipulation
- 1.18 Which of the following features cannot be captured by context-free grammars?
- (a) Syntax of if-then-else statements
 - (b) Syntax of recursive procedures
 - (c) Whether a variable has been declared before its use
 - (d) Variable names of arbitrary length

- 1.19. Which of the following algorithm design techniques is used in the quicksort algorithm?
- (a) Dynamic programming (b) Backtracking
(c) Divide and conquer (d) Greedy method
- 1.20. In which one of the following cases is it possible to obtain different results for call-by reference and call-by-name parameter passing methods?
- (a) Passing a constant value as a parameter
(b) Passing the address of an array as a parameter
(c) Passing an array element as a parameter
(d) Passing an array following statements is true
- 1.21. Which one of the following statements is true?
- (a) Macro definitions cannot appear within other macro definitions in assembly language programs
(b) Overlaying is used to run a program which is longer than the address space of computer
(c) Virtual memory can be used to accommodate a program which is longer than the address space of a computer
(d) It is not possible to write interrupt service routines in a high level language
- 1.22. Which one of the following statements is false?
- (a) Optimal binary search tree construction can be performed efficiently using dynamic programming.
(b) Breadth-first search cannot be used to find converted components of a graph
(c) Given the prefix and postfix walks over a binary tree, the binary tree cannot be uniquely constructed.
(d) Depth-first search can be used to find connected components of a graph.

- 1.23. Consider the following two functions:

$$g_1(n) = \begin{cases} n^3 & \text{for } 0 \leq n \leq 10,000 \\ n^2 & \text{for } n \geq 10,000 \end{cases}$$

$$g_2(n) = \begin{cases} n & \text{for } 0 \leq n \leq 100 \\ n^3 & \text{for } n > 100 \end{cases}$$

Which of the following is true?

- (a) $g_1(n)$ is $O(g_2(n))$ (b) $g_1(n)$ is $O(n^3)$
(c) $g_2(n)$ is $O(g_1(n))$ (d) $g_2(n)$ is $O(n)$

- 1.24. Consider the following heap (figure) in which blank regions are not in use and hatched region are in use.

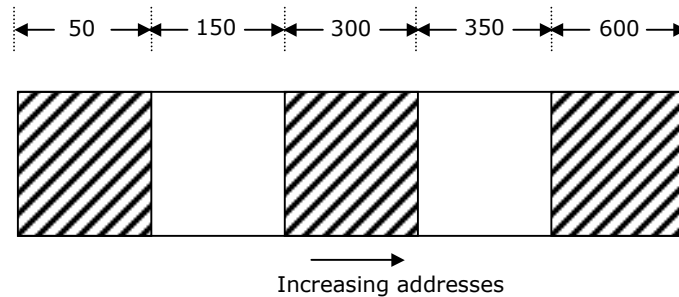

- The sequence of requests for blocks of size 300, 25, 125, 50 can be satisfied if we use
- either first fit or best fit policy (any one)
 - first fit but not best fit policy
 - best fit but first fit policy
 - None of the above

2. Fill in the blanks:

- The number of flip-flops required to construct a binary modulo N counter is _____
- On the set N of non-negative integers, the binary operation _____ is associative and non-commutative.
- Amongst the properties {reflexivity, symmetry, anti-symmetry, transitivity} the relation $R = \{(x,y) \in N^2 \mid x \neq y\}$ satisfies _____
- The number of subsets $\{1,2,\dots,n\}$ with odd cardinality is _____
- The number of edges in a regular graph of degree d and n vertices is _____
- The probability of an event B is P_1 . The probability that events A and B occur together is P_2 while the probability that A and \bar{B} occur together is P_3 . The probability of the event A in terms of P_1, P_2 and P_3 is _____
- Consider n -bit (including sign bit) 2's complement representation of integer number. The range of integer values, N , that can be represented is _____ $\leq N \leq$ _____
- Let A, B and C be independent events which occur with probabilities 0.8, 0.5 and 0.3 respectively. The probability of occurrence of at least one of the event is _____
- The Hasse diagrams of all the lattices with up to four elements are _____ (write all the relevant Hasse diagrams).

2.10. The regular expression for the language recognized by the finite state automaton of figure is _____

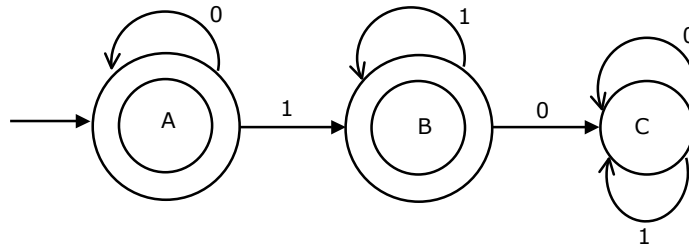

3. Answer the following questions as indicated.

3.1. State True or False with one line explanation

Multiplexing of address/data lines in 8085 microprocessor reduces the instruction execution time.

3.2. State True or False with one line explanation

Expanding opcode instruction formats are commonly employed in RISC. (Reduced Instruction Set Computers) machines.

3.3. State True or False with one line explanation

A FSM (Finite State Machine) can be designed to add two integers of any arbitrary length (arbitrary number of digits).

3.4. Match the following items

(i) Newton-Raphson	(a) Integration
(ii) Runge-Kutta	(b) Root finding
(iii) Gauss-Seidel	(c) Ordinary Differential Equations
(iv) Simpson's Rule	(d) Solutions of Systems of Linear Equations

3.5. Match the following items

(i) Backus-Naur form	(a) Regular expressions
(ii) Lexical analysis	(b) LALR(I) grammars
(iii) YACC	(c) LL(I) grammars
(iv) Recursive descent parsing	(d) General context-free grammars

- 3.6. State True or False with reason
There is always a decomposition into Boyce-Codd normal form (BCNF) that is lossless and dependency preserving.
- 3.7. An instance of a relational scheme $R(A, B, C)$ has distinct values for attribute A. Can you conclude that A is a candidate key for R?
- 3.8. Give a relational algebra expression using only the minimum number of operators from $(\cup, -)$ which is equivalent to $R \cap S$.
- 3.9. Every subset of a countable set is countable.
State whether the above statement is true or false with reason.
- 3.10. Match the following items

(i) ECL	(a) Unipolar; very high speed difficult to fabricate; good resistance to radiation
(ii) Ga As	(b) Unipolar; low power; modest speed and packing density
(iii) TTL	(c) Bipolar; highest speed silicon IC; low packing density
(iv) CMOS	(d) Bipolar, modes packing density, inexpensive

- 3.11. State True or False with reason
Logical data independence is easier to achieve than physical data independence
- 3.12. Find the inverse of the matrix $\begin{bmatrix} 1 & 0 & 1 \\ -1 & 1 & 1 \\ 0 & 1 & 0 \end{bmatrix}$
- 3.13. Let p and q be propositions. Using only the truth table decide whether $p \Leftrightarrow q$ does not imply $p \rightarrow \neg q$ is true or false.
4. (a) Let * be a Boolean operation defined as $A * B = AB + \bar{A} \bar{B}$
If $C = A * B$ then evaluate and fill in the blanks:
(i) $A * A =$ _____
(ii) $C * A =$ _____
(b) Solve the following boolean equations for the values of A, B and C:
 $AB + \bar{A}C = 1$
 $AC + B = 0$

5. A 3-ary tree is a tree in which every internal node has exactly three children. Use induction to prove that the number of leaves in a 3-ary tree with n internal nodes is $2(n - 1) + 3$.

6. What function of x, n is computed by this program?

Function what (x, n :integer): integer:

Var

value : integer;

begin

value:=1

if $n > 0$ then

begin

if $n \bmod 2 = 1$ then

value:=value*x;

value:=value*what($x*x, n \text{ div } 2$);

end;

what:value

end;

7. An array A contains n integers in locations $A[0], A[1], \dots, A[n-1]$. It is required to shift the elements of the array cyclically to the left by K places, where $1 \leq K \leq n-1$. An incomplete algorithm for doing this in linear time, without using another is given below. Complete the algorithm by filling in the blanks. Assume all variables are suitably declared.

min:=n;

i=0;

while _____do

begin

temp:=A[i];

j:=i;

while _____do

begin

A[j]:=_____;

j:=(j+K) mod n;

if $j < \text{min}$ then

min:=j;

end;

A[(n+i-K) mod n]:=_____;

i:=_____;

end;

8. A rooted tree with 12 nodes has its nodes numbered 1 to 12 in pre-order. When the tree is traversed in post-order, the nodes are visited in the order 3, 5, 4, 2, 7, 8, 6, 10, 11, 12, 9, 1. Reconstruct the original tree from this information, that is, find the parent of each node, and show the tree diagrammatically.

SECTION – B

Answer any TEN questions in this section.

9. Following 7 bit single error correcting Hamming coded message is received. (figure below):

7	6	5	4	3	2	1	bit No.
1	0	0	0	1	1	0	

Determine if the message is correct (assuming that at most 1 bit could be corrupted). If the message contains an error find the bit which is erroneous and gives the correct message.

10. Write a program in 8085 Assembly language to Add two 16-bit unsigned BCD(8-4-2-1 Binary Coded Decimal) number. Assume the two input operands are in BC and DE Register pairs. The result should be placed in the register pair BC. (Higher order register in the register pair contains higher order digits of operand)
11. Find the contents of the flip-flop Q_2, Q_1 and Q_0 in the circuit of figure, after giving four clock pulses to the clock terminal. Assume $Q_2Q_1Q_0 = 000$ initially.

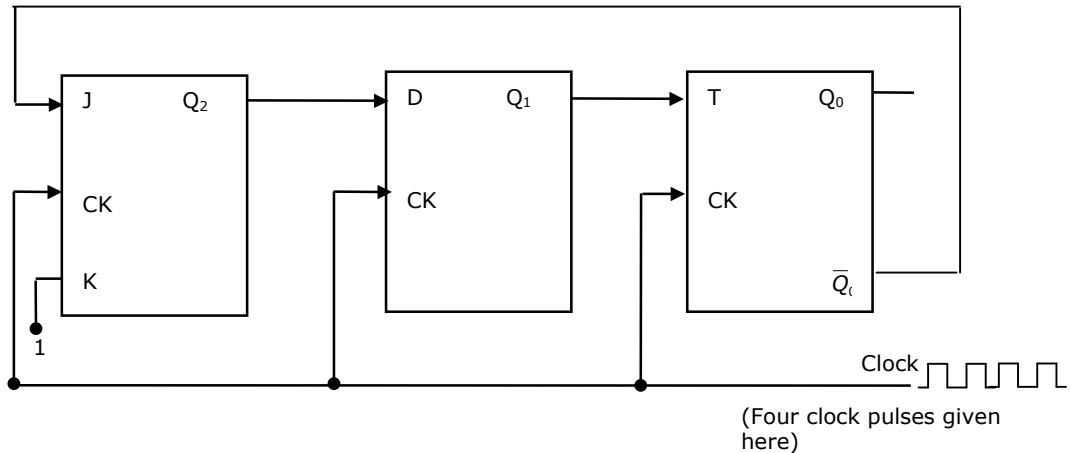

12. (a) Assume that a CPU has only two registers R_1 and R_2 and that only the following instruction is available $XOR R_i, R_j; \{R_j \leftarrow R_i \oplus R_j, \text{ for } i, j = 1, 2\}$

Using this XOR instruction, find an instruction sequence in order to exchange the contents of the registers R_1 and R_2 .

- (b) The line p of the circuit shown in figure has stuck at 1 fault. Determine an input test to detect the fault.

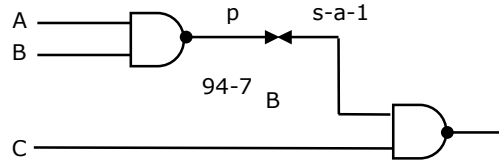

13. Consider the following relational schema:

COURSES (cno, cname)

STUDENTS (rollno, sname, age, year)

REGISTERED FOR (cno, rollno)

The underlined attributes indicate the primary keys for the relations. The 'year' attribute for the STUDENTS relation indicates the year in which the student is currently studying (First year, Second year etc.)

- (a) Write a relational algebra query to
Print the roll number of students who have registered for cno 322.
- (b) Write a SQL query to
Print the age and year of the youngest student in each year.

14. Consider B^+ - tree of order d shown in figure?

(A) B^+ - tree of order d contains between d and 2d keys in each node

- (a) Draw the resulting B^+ - tree after inserted in the figure.

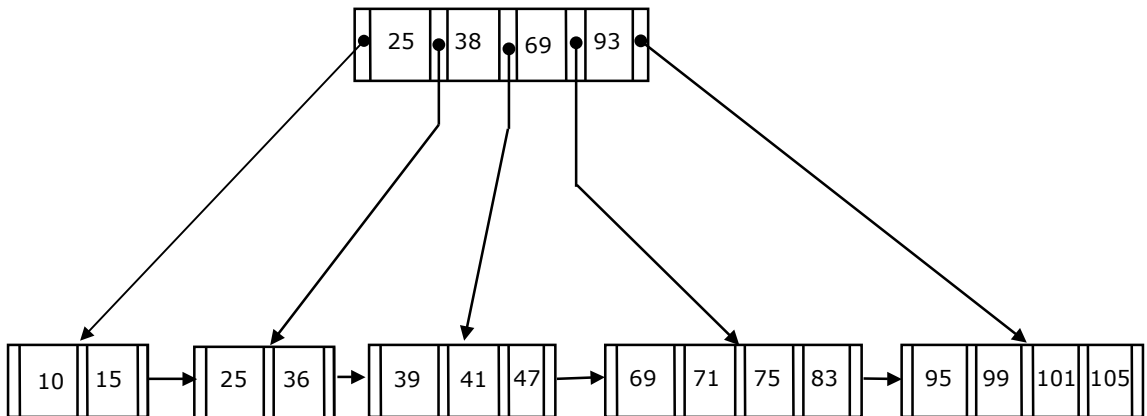

- (b) For a B^+ - tree of order d with n leaf nodes, the number of nodes accessed during a search is $O(\log_d n)$.

15. (a) Use the patterns given to prove that

$$\sum_{i=0}^{n-1} (2i + 1) = n^2$$

(You are not permitted to employ induction)

$$\begin{array}{ccccccc} & & & & \cdot & \cdot & \cdot \\ & & & & \cdot & \cdot & \cdot \\ & & \cdot & \cdot & \cdot & \cdot & \cdot \\ \cdot & \cdot & \cdot & \cdot & \cdot & \cdot & \cdot \text{ etc} \\ 1 & & 4 & & 9 & & \end{array}$$

- (b) Use the result obtained in (a) to prove that

$$\sum_{i=1}^n i = \frac{n(n+1)}{2}$$

16. Every element a of some ring $(R, +, 0)$ satisfies the equation $aoa = a$.

Decide whether or not the ring is commutative.

17. State whether the following statements are True or False with reasons for your answer:

(a) Coroutine is just another name for a subroutine.

(b) A two pass assembler uses its machine opcode table in the first pass of assembly.

18. State whether the following statements are True or False with reasons for your answer

(a) A subroutine cannot always be used to replace a macro in an assembly language program.

(b) A symbol declared as 'external' in assembly language is assigned an address outside the program by the assembler itself.

19. (a) Given a set

$$S = \{x \mid \text{there is an } x\text{-block of } 5\text{'s in the decimal expansion of } \pi\}$$

(Note: x -block is a maximal block of x successive 5's)

Which of the following statements is true with respect to S ? No reasons need to be given for the answer.

(i) S is regular

(ii) S is recursively enumerable

(iii) S is not recursively enumerable

(iv) S is recursive

- (b) Given that a language L_1 is regular and that the language $L_1 \cup L_2$ is regular, is the language L_2 always regular? Prove your answer.

20. A grammar G is in Chomsky-Normal Form (CNF) if all its productions are of the form $A \rightarrow BC$ or $A \rightarrow a$, where A, B and C , are non-terminals and a is a terminal. Suppose G is a CFG in CNF and w is a string in $L(G)$ of length, then how long is a derivation of w in G ?

21. Consider the following recursive function:

```
function fib (1:integer);integer;  
begin  
if (n=0) or (n=1) then fib:=1  
else fib:=fib(n-1) + fib(n-2)  
end;
```

The above function is run on a computer with a stack of 64 bytes. Assuming that only return address and parameter and passed on the stack, and that an integer value and an address takes 2 bytes each, estimate the maximum value of n for which the stack will not overflow. Give reasons for your answer.

22. Consider the program below:

```
Program main;  
  var r:integer;  
  procedure two;  
  begin write (r) end;  
  procedure one;  
  var r:integer;  
  begin r:=5 two; end  
  begin r:=2;  
  two; one; two;  
  end.
```

What is printed by the above program if

- (i) Static scoping is assumed for all variables;
- (ii) Dynamic scoping is assumed for all variables.

Give reasons for your answer.

23. Suppose we have a computer with a single register and only three instructions given below:

```
LOAD addren    ; load register  
                ; from addren  
STORE addren   ; store register  
                ; at addren  
ADD addren     ; add register to  
                ; contents of addren  
                ; and place the result  
                ; in the register
```

Consider the following grammar:

$$A \rightarrow id := E \quad E \rightarrow E + T | T \quad T \rightarrow (E) | id$$

Write a syntax directed translation to generate code using this grammar for the computer described above.

24. An independent set in a graph is a subset of vertices such that no two vertices in the subset are connected by an edge. An incomplete scheme for a greedy algorithm to find a maximum independent set in a tree is given below:

```

V: Set of all vertices in the tree;      I:= $\phi$ ;
While V  $\neq \phi$  do
begin
    select a vertex u:  $\in V$  such that
    V:=V - {u};
    if u is such that
    then I:= I  $\cup$  {u}
    end;
    output(I);

```

- (a) Complete the algorithm by specifying the property of vertex u in each case
(b) What is the time complexity of the algorithm.

25. An array a contains n integers in non-decreasing order, $A[1] \leq A[2] \leq \dots \leq A[n]$. Describe, using Pascal like pseudo code, a linear time algorithm to find i, j, such that $A[i] + A[j] =$ a given integer M, if such i, j exist.

26. A queue Q containing n items and an empty stack S are given. It is required to transfer all the items from the queue to the stack, so that the item at the front of queue is on the top of the stack, and the order of all other items is preserved. Show how this can be done in $O(n)$ time using only a constant amount of additional storage. Note that the only operations which can be performed on the queue and stack are Delete, Insert, Push and Pop. Do not assume any implementation of the queue or stack.

27. (a) Draw a precedence graph for the following sequential code. The statements are numbered from S_1 to S_6

```

S1          read n
S2          i:=1
S3          if i>n goto next
S4          a(i):=i+1
S5          i:=i+1
S6          next : Write a(i)

```

(b) Can this graph be converted to a concurrent program using parbegin-parend construct only?

28. Consider the resource allocation graph given in the figure.

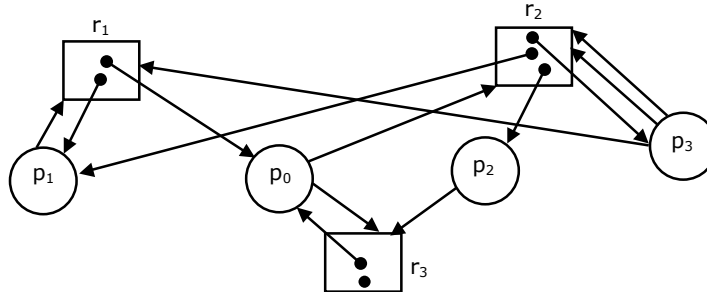

(a) Find if the system is in a deadlock state.

(b) Otherwise, find a safe sequence.