

Q.1 – Q.30 carry one mark each.

1. Consider the following C function.

```
float f,(float x, int y) {  
    float p, s; int i;  
    for (s=1,p=1,i=1; i<y; i++) {  
        p *= x/i;  
        s+=p;  
    }  
    return s;  
}
```

For large values of y , the return value of the function f best approximates

- (A) X^y (B) e^x (C) $\ln(1+x)$ (D) X^x
2. Assume the following C variable declaration
`int * A[10], B[10][10];`
Of the following expressions
I. `A[2]` II. `A[2][3]` III. `B[1]` IV. `B[2][3]`
which will not give compile-time errors if used as left hand sides of assignment statements in a C program?
(A) I,II, and IV only (B) II, III, and IV only
(C) II and IV only (D) IV only
3. Let $P(E)$ denote the probability of the event E . Given $P(A) = 1$, $P(B) = \frac{1}{2}$, the values of $P(A|B)$ and $P(B|A)$ respectively are
(A) $\frac{1}{4}, \frac{1}{2}$ (B) $\frac{1}{2}, \frac{1}{4}$ (C) $\frac{1}{2}, 1$ (D) $1, \frac{1}{2}$
4. Let A be a sequence of 8 distinct integers sorted in ascending order. How many distinct pairs of sequences, B and C are there such that (i) each is sorted in ascending order, (ii) B has 5 and C has 3 elements, and (iii) the result of merging B and C gives A ?
(A) 2 (B) 30 (C) 56 (D) 256
5. n couples are invited to a party with the condition that every husband should be accompanied by his wife. However, a wife need not be accompanied by her husband. The number of different gatherings possible at the party is
(A) $\binom{2n}{n} * 2^n$ (B) 3^n (C) $\frac{(2n)!}{2^n}$ (D) $\binom{2n}{n}$

6. Let $T(n)$ be the number of different binary search trees on n distinct elements. Then $T(n) = \sum_{k=1}^n T(k-1)T(x)$, where x is
- (A) $n - k + 1$ (B) $n - k$ (C) $n - k - 1$ (D) $n - k - 2$
7. Consider the set Σ^* of all strings over the alphabet $\Sigma = \{0, 1\}$. Σ^* with the concatenation operator for strings
- (A) does not form a group
 (B) forms a non-commutative group
 (C) does not have a right identity element
 (D) forms a group if the empty string is removed from Σ^*
8. Let G be an arbitrary graph with n nodes and k components. If a vertex is removed from G , the number of components in the resultant graph must necessarily lie between
- (A) k and n (B) $k - 1$ and $k + 1$
 (C) $k - 1$ and $n - 1$ (D) $k + 1$ and $n - k$
9. Assuming all numbers are in 2's complement representation, which of the following numbers is divisible by 11111011?
- (A) 11100111 (B) 11100100 (C) 11010111 (D) 11011011
10. For a pipelined CPU with a single ALU, consider the following situations
- I. The $j + 1$ -st instruction uses the result of the j -th instruction as an operand
 II. The execution of a conditional jump instruction
 III. The j -th and $j + 1$ -st instructions require the ALU at the same time
- Which of the above can cause a hazard?
- (A) I and II only (B) II and III only (C) III only (D) All the three
11. Consider an array multiplier for multiplying two n bit numbers. If each gate in the circuit has a unit delay, the total delay of the multiplier is
- (A) $\Theta(1)$ (B) $\Theta(\log n)$ (C) $\Theta(n)$ (D) $\Theta(n^2)$
12. Ram and Shyam have been asked to show that a certain problem Π is NP-complete. Ram shows a polynomial time reduction from the 3-SAT problem to Π , and Shyam shows a polynomial time reduction from Π to 3-SAT. Which of the following can be inferred from these reductions?
- (A) Π is NP-hard but not NP-complete (B) Π is in NP, but is not NP-complete
 (C) Π is NP-complete (D) Π is neither NP-hard, nor in NP

13. Nobody knows yet if $P = NP$. Consider the language L defined as follows.

$$L = \begin{cases} (0+1)^* & \text{if } P = NP \\ \phi & \text{otherwise} \end{cases}$$

- Which of the following statements is true?
- (A) L is recursive
(B) L is recursively enumerable but not recursive
(C) L is not recursively enumerable
(D) Whether L is recursive or not will be known after we find out if $P = NP$
14. The regular expression $0^*(10^*)^*$ denotes the same set as
- (A) $(1^*0)^*1^*$ (B) $0+(0+10)^*$
(C) $(0+1)^*10(0+1)^*$ (D) None of the above
15. If the strings of a language L can be effectively enumerated in lexicographic (i.e., alphabetic) order, which of the following statements is true?
- (A) L is necessarily finite
(B) L is regular but not necessarily finite
(C) L is context free but not necessarily regular
(D) L is recursive but not necessarily context free
16. Which of the following suffices to convert an arbitrary CFG to an LL(1) grammar?
- (A) Removing left recursion alone
(B) Factoring the grammar alone
(C) Removing left recursion and factoring the grammar
(D) None of the above
17. Assume that the SLR parser for a grammar G has n_1 states and the LALR parser for G has n_2 states. The relationship between n_1 and n_2 is
- (A) n_1 is necessarily less than n_2 (B) n_1 is necessarily equal to n_2
(C) n_1 is necessarily greater than n_2 (D) None of the above
18. In a bottom-up evaluation of a syntax directed definition, inherited attributes can
- (A) always be evaluated
(B) be evaluated only if the definition is L-attributed
(C) be evaluated only if the definition has synthesized attributes
(D) never be evaluated

23. In a heap with n elements with the smallest element at the root, the 7th smallest element can be found in time
(A) $\Theta(n \log n)$ (B) $\Theta(n)$ (C) $\Theta(\log n)$ (D) $\Theta(1)$
24. Which of the following statements is FALSE?
(A) In statically typed languages, each variable in a program has a fixed type
(B) In un-typed languages, values do not have any types
(C) In dynamically typed languages, variables have no types
(D) In all statically typed languages, each variable in a program is associated with values of only a single type during the execution of the program
25. Using a larger block size in a fixed block size file system leads to
(A) better disk throughput but poorer disk space utilization
(B) better disk throughput and better disk space utilization
(C) poorer disk throughput but better disk space utilization
(D) poorer disk throughput and poorer disk space utilization
26. In a system with 32 bit virtual addresses and 1KB page size, use of one-level page tables for virtual to physical address translation is not practical because of
(A) the large amount of internal fragmentation
(B) the large amount of external fragmentation
(C) the large memory overhead in maintaining page tables
(D) the large computation overhead in the translation process
27. Which of the following assertions is FALSE about the Internet Protocol (IP)?
(A) It is possible for a computer to have multiple IP addresses
(B) IP packets from the same source to the same destination can take different routes in the network
(C) IP ensures that a packet is discarded if it is unable to reach its destination within a given number of hops
(D) The packet source cannot set the route of an outgoing packets; the route is determined only by the routing tables in the routers on the way
28. Which of the following functionalities *must* be implemented by a transport protocol over and above the network protocol?
(A) Recovery from packet losses (B) Detection of duplicate packets
(C) Packet delivery in the correct order (D) End to end connectivity

29. Which of the following scenarios may lead to an irrecoverable error in a database system?
- (A) A transaction writes a data item after it is read by an uncommitted transaction
 - (B) A transaction reads a data item after it is read by an uncommitted transaction
 - (C) A transaction reads a data item after it is written by a committed transaction
 - (D) A transaction reads a data item after it is written by an uncommitted transaction

30. Consider the following SQL query

```
select distinct a1, a2, ..., an
from r1, r2, ..., rm
where P
```

For an arbitrary predicate P , this query is equivalent to which of the following relational algebra expressions?

- (A) $\Pi_{a_1, a_2, \dots, a_n} \sigma_P (r_1 \times r_2 \times \dots \times r_m)$
- (B) $\Pi_{a_1, a_2, \dots, a_n} \sigma_P (r_1 \bowtie r_2 \bowtie \dots \bowtie r_m)$
- (C) $\Pi_{a_1, a_2, \dots, a_n} \sigma_P (r_1 \cup r_2 \cup \dots \cup r_m)$
- (D) $\Pi_{a_1, a_2, \dots, a_n} \sigma_P (r_1 \cap r_2 \cap \dots \cap r_m)$

Q. 31-90 carry two marks each.

31. Let (S, \leq) be a partial order with two *minimal* elements a and b , and a maximum element c . Let $P: S \rightarrow \{\mathbf{True}, \mathbf{False}\}$ be a predicate defined on S . Suppose that $P(a) = \mathbf{True}$, $P(b) = \mathbf{False}$ and $P(x) \Rightarrow P(y)$ for all $x, y \in S$ satisfying $x \leq y$, where \Rightarrow stands for logical implication. Which of the following statements CANNOT be true?
- (A) $P(x) = \mathbf{True}$ for all $x \in S$ such that $x \neq b$
 - (B) $P(x) = \mathbf{False}$ for all $x \in S$ such that $x \neq a$ and $x \neq c$
 - (C) $P(x) = \mathbf{False}$ for all $x \in S$ such that $b \leq x$ and $x \neq c$
 - (D) $P(x) = \mathbf{False}$ for all $x \in S$ such that $a \leq x$ and $b \leq x$
32. Which of the following is a valid first order formula? (Here α and β are first order formulae with x as their only free variable)
- (A) $((\forall x)[\alpha] \Rightarrow (\forall x)[\beta]) \Rightarrow (\forall x)[\alpha \Rightarrow \beta]$
 - (B) $(\forall x)[\alpha] \Rightarrow (\exists x)[\alpha \wedge \beta]$
 - (C) $((\forall x)[\alpha \vee \beta] \Rightarrow (\exists x)[\alpha] \Rightarrow (\forall x)[\alpha])$
 - (D) $(\forall x)[\alpha \Rightarrow \beta] \Rightarrow ((\forall x)[\alpha] \Rightarrow (\forall x)[\beta])$

33. Consider the following formula α and its two interpretations I_1 and I_2
 $\alpha: (\forall x)[Px \Leftrightarrow (\forall y)[Qxy \Leftrightarrow \neg Qyy]] \Rightarrow (\forall x)[\neg Px]$
 I_1 : Domain: the set of natural numbers
 $P_x \equiv$ 'x is a prime number'
 $Qxy \equiv$ 'y divides x'
 I_2 : same as I_1 except that $Px =$ 'x is a composite number'.
 Which of the following statements is true?
 (A) I_1 satisfies α , I_2 does not (B) I_2 satisfies α , I_1 does not
 (C) Neither I_2 nor I_1 satisfies α (D) Both I_1 and I_2 satisfy α
34. m identical balls are to be placed in n distinct bags. You are given that $m \geq kn$, where k is a natural number ≥ 1 . In how many ways can the balls be placed in the bags if each bag must contain at least k balls?
 (A) $\binom{m-k}{n-1}$ (B) $\binom{m-kn+n-1}{n-1}$
 (C) $\binom{m-1}{n-k}$ (D) $\binom{m-kn+n+k-2}{n-k}$
35. Consider the following recurrence relation
 $T(1) = 1$
 $T(n+1) = T(n) + \lfloor \sqrt{n+1} \rfloor$ for all $n \geq 1$
 The value of $T(m^2)$ for $m \geq 1$ is
 (A) $\frac{m}{6}(21m-39)+4$ (B) $\frac{m}{6}(4m^2-3m+5)$
 (C) $\frac{m}{2}(3m^{2.5}-11m+20)-5$ (D) $\frac{m}{6}(5m^3-34m^2+137m-104)+\frac{5}{6}$
36. How many perfect matching are there in a complete graph of 6 vertices?
 (A) 15 (B) 24 (C) 30 (D) 60
37. Let $f: A \rightarrow B$ be an injective (one-to-one) function. Define $g: 2^A \rightarrow 2^B$ as:
 $g(C) = \{f(x) \mid x \in C\}$, for all subsets C of A .
 Define $h: 2^B \rightarrow 2^A$ as: $h(D) = \{x \mid x \in A, f(x) \in D\}$, for all subsets D of B .
 Which of the following statements is always true?
 (A) $g(h(D)) \subseteq D$ (B) $g(h(D)) \supseteq D$
 (C) $g(h(D)) \cap D = \phi$ (D) $g(h(D)) \cap (B-D) \neq \phi$
-

42. A piecewise linear function $f(x)$ is plotted using thick solid lines in the figure below (the plot is drawn to scale).

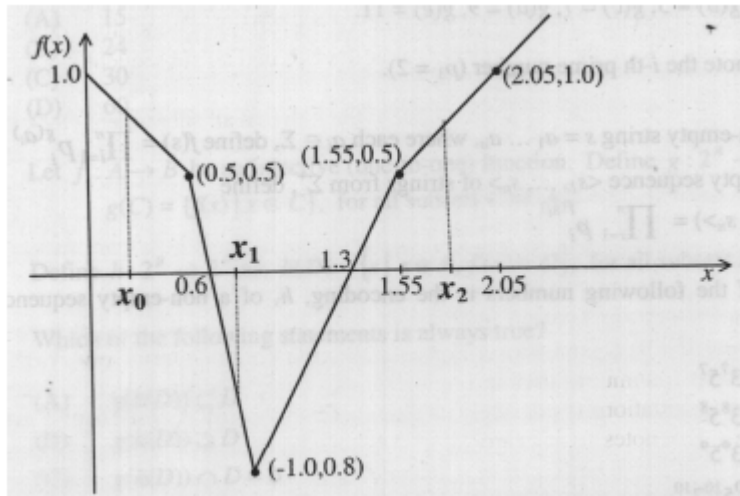

- If we use the Newton-Raphson method to find the roots of $f(x) = 0$ using x_0 , x_1 , and x_2 respectively as initial guesses, the roots obtained would be
- (A) 1.3, 0.6, and 0.6 respectively (B) 0.6, 0.6, and 1.3 respectively
 (C) 1.3, 1.3, and 0.6 respectively (D) 1.3, 0.6, and 1.3 respectively
43. The following is a scheme for floating point number representation using 16 bits.

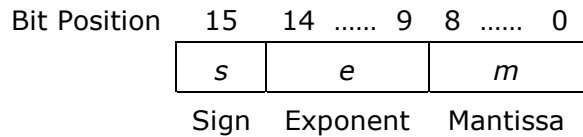

Let s , e , and m be the numbers represented in binary in the sign, exponent, and mantissa fields respectively. Then the floating point number represented is:

$$\begin{cases} (-1)^s (1 + m \times 2^{-9}) 2^{e-31}, & \text{if the exponent} \neq 111111 \\ 0, & \text{otherwise} \end{cases}$$

What is the maximum difference between two successive real numbers representable in this system?

- (A) 2^{-40} (B) 2^{-9} (C) 2^{22} (D) 2^{31}
44. A 1-input, 2-output synchronous sequential circuit behaves as follows:
 Let z_k , n_k denote the number of 0's and 1's respectively in initial k bits of the input
 ($z_k + n_k = k$). The circuit outputs 00 until one of the following conditions holds.
- $z_k - n_k = 2$. In this case, the output at the k -th and all subsequent clock ticks is 10.

- $n_k - z_k = 2$. In this case, the output at the k -th and all subsequent clock ticks is 01.

What is the minimum number of states required in the state transition graph of the above circuit?

- (A) 5 (B) 6 (C) 7 (D) 8

45. The literal count of a Boolean expression is the sum of the number of times each literal appears in the expression. For example, the literal count of $(xy + xz')$ is 4. What are the minimum possible literal counts of the product-of-sum and sum-of-product representations respectively of the function given by the following Karnaugh map? Here, X denotes "don't care"

$xy \backslash zw$	00	01	11	10
00	X	1	0	1
01	0	1	X	0
11	1	X	X	0
10	X	0	0	X

- (A) (11, 9) (B) (9, 13) (C) (9, 10) (D) (11, 11)

46. Consider the ALU shown below.

GATE Forum

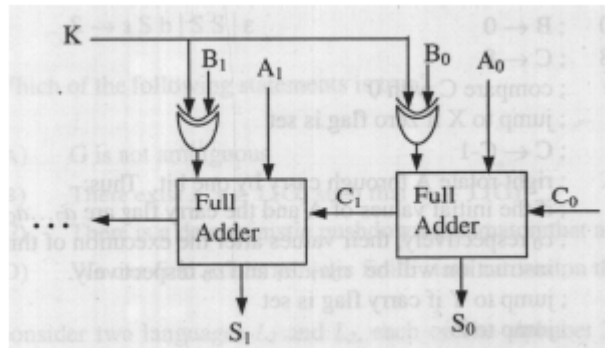

If the operands are in 2's complement representation, which of the following operations can be performed by suitably setting the control lines K and C_0 only (+ and - denote addition and subtraction respectively)?

- (A) $A + B$, and $A - B$, but not $A + 1$ (B) $A + B$, and $A + 1$, but not $A - B$
 (C) $A + B$, but not $A - B$ or $A + 1$ (D) $A + B$, and $A - B$, and $A + 1$

47. Consider the following circuit composed of XOR gates and non-inverting buffers.

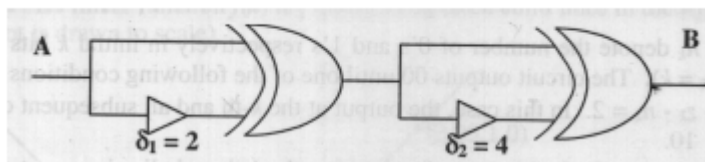

50. Consider the following deterministic finite state automaton M.

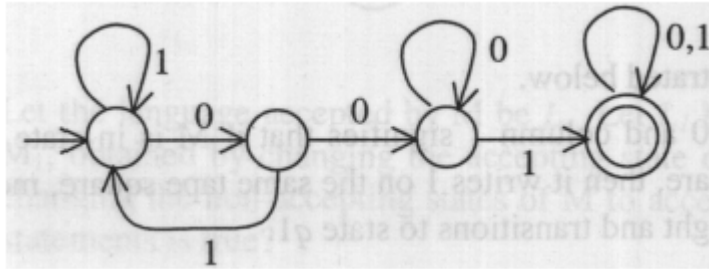

- Let S denote the set of seven bit binary strings in which the first, the fourth, and the last bits are 1. The number of strings in S that are accepted by M is
- (A) 1 (B) 5 (C) 7 (D) 8

51. Let $G = (\{S\}, \{a, b\}, R, S)$ be a context free grammar where the rule set R is $S \rightarrow a S b \mid S S \mid \epsilon$

Which of the following statements is true?

- (A) G is not ambiguous
 (B) There exist $x, y \in L(G)$ such that $xy \notin L(G)$
 (C) There is a deterministic pushdown automaton that accepts $L(G)$
 (D) We can find a deterministic finite state automaton that accepts $L(G)$

52. Consider two languages L_1 and L_2 , each on the alphabet Σ . Let $f: \Sigma \rightarrow \Sigma$ be a polynomial time computable bijection such that $(\forall x)[x \in L_1 \text{ iff } f(x) \in L_2]$. Further, let f^{-1} be also polynomial time computable.

Which of the following CANNOT be true?

- (A) $L_1 \in P$ and L_2 is finite
 (B) $L_1 \in NP$ and $L_2 \in P$
 (C) L_1 is undecidable and L_2 is decidable
 (D) L_1 is recursively enumerable and L_2 is recursive

53. A single tape Turing Machine M has two states q_0 and q_1 , of which q_0 is the starting state. The tape alphabet of M is $\{0, 1, B\}$ and its input alphabet is $\{0, 1\}$. The symbol B is the blank symbol used to indicate end of an input string. The transition function of M is described in the following table.

	0	1	B
q_0	$q_1, 1, R$	$q_1, 1, R$	Halt
q_1	$q_1, 1, R$	$q_0, 1, L$	q_0, B, L

The table is interpreted as illustrated below.

The entry $(q_1, 1, R)$ in row q_0 and column 1 signifies that if M is in state q_0 and reads 1 on the current tape square, then it writes 1 on the same tape square, moves its tape head one position to the right and transitions to state q_1 .

Which of the following statements is true about M?

- (A) M does not halt on any string in $(0+1)^+$
- (B) M does not halt on any string in $(00+1)^*$
- (C) M halts on all strings ending in a 0
- (D) M halts on all strings ending in a 1

54. Define languages L_0 and L_1 as follows:

$$L_0 = \{ \langle M, w, 0 \rangle \mid M \text{ halts on } w \}$$

$$L_1 = \{ \langle M, w, 1 \rangle \mid M \text{ does not halt on } w \}$$

Here $\langle M, w, i \rangle$ is a triplet, whose first component, M , is an encoding of a Turing Machine, second component, w , is a string, and third component, i , is a bit.

Let $L = L_0 \cup L_1$. Which of the following is true?

- (A) L is recursively enumerable, but \bar{L} is not
- (B) \bar{L} is recursively enumerable, but L is not
- (C) Both L and \bar{L} are recursive
- (D) Neither L nor \bar{L} is recursively enumerable

55. Consider the NFA M shown below.

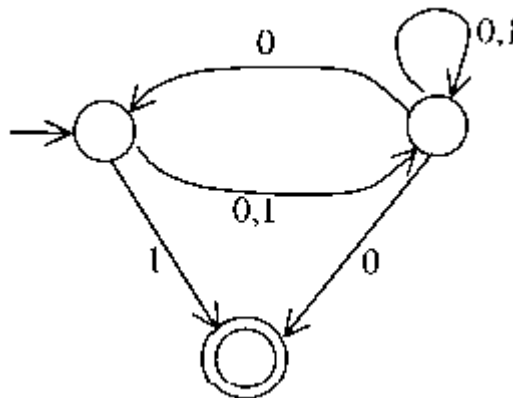

Let the language accepted by M be L . Let L_1 be the language accepted by the NFA M_1 obtained by changing the accepting state of M to a non-accepting state and by changing the non-accepting states of M to accepting states. Which of the following statements is true?

- (A) $L_1 = \{0,1\}^* - L$
- (B) $L_1 = \{0,1\}^*$
- (C) $L_1 \subseteq L$
- (D) $L_1 = L$

56. Consider the grammar shown below

$$S \rightarrow i E t S S' \mid a$$

$$S' \rightarrow e S \mid \epsilon$$

$$E \rightarrow b$$

In the predictive parse table, M , of this grammar, the entries $M[S',e]$ and $M[S',\$]$ respectively are

- (A) $\{S' \rightarrow e S\}$ and $\{S' \rightarrow \epsilon\}$ (B) $\{S' \rightarrow e S\}$ and $\{ \}$
 (C) $\{S' \rightarrow \epsilon\}$ and $\{S' \rightarrow \epsilon\}$ (D) $\{S' \rightarrow e S, S' \rightarrow \epsilon\}$ and $\{S' \rightarrow \epsilon\}$

57. Consider the grammar shown below.

$S \rightarrow C C$
 $C \rightarrow c C \mid d$

This grammar is

- (A) LL(1) (B) SLR(1) but not LL(1)
 (C) LALR(1) but not SLR(1) (D) LR(1) but not LALR(1)

58. Consider the translation scheme shown below.

$S \rightarrow T R$
 $R \rightarrow + T \{print('+');\} R \mid \epsilon$
 $T \rightarrow \mathbf{num} \{print(\mathbf{num.val});\}$

Here **num** is a token that represents an integer and **num.val** represents the corresponding integer value. For an input string '9 + 5 + 2', this translation scheme will print

- (A) 9 + 5 + 2 (B) 9 5 + 2 + (C) 9 5 2 + + (D) + + 9 5 2

59. Consider the syntax directed definition shown below.

$S \rightarrow \mathbf{id} := E \quad \{gen(\mathbf{id.place} = E.place);\}$
 $E \rightarrow E_1 + E_2 \quad \{t = newtemp();$
 $\quad \quad \quad gen(t = E_1.place + E_2.place);$
 $\quad \quad \quad E.place = t;\}$
 $E \rightarrow \mathbf{id} \quad \quad \quad \{E.place = \mathbf{id.place};\}$

Here, *gen* is a function that generates the output code, and *newtemp* is a function that returns the name of a new temporary variable on every call. Assume that *t*'s are the temporary variable names generated by *newtemp*. For the statement 'X := Y + Z', the 3-address code sequence generated by this definition is

- (A) X = Y + Z (B) $t_1 = Y + Z; X = t_1$
 (C) $t_1 = Y; t_2 = t_1 + Z; X = t_2$ (D) $t_1 = Y; t_2 = Z; t_3 = t_1 + t_2; X = t_3$

60. A program consists of two modules executed sequentially. Let $f_1(t)$ and $f_2(t)$ respectively denote the probability density functions of time taken to execute the two modules. The probability density function of the overall time taken to execute the program is given by

- (A) $f_1(t) + f_2(t)$ (B) $\int_0^t f_1(x) f_2(x) dx$

$$(C) \int_0^t f_1(x) f_2(t-x) dx$$

$$(D) \max\{f_1(t), f_2(t)\}$$

The following information pertains to 61-62:

In a permutation $a_1 \dots a_n$, of n distinct integers, an inversion is a pair (a_i, a_j) such that $i < j$ and $a_i > a_j$.

61. If all permutations are equally likely, what is the expected number of inversions in a randomly chosen permutation of $1 \dots n$?

(A) $\frac{n(n-1)}{2}$ (B) $\frac{n(n-1)}{4}$ (C) $\frac{n(n+1)}{4}$ (D) $2n[\log_2 n]$

62. What would be the worst case time complexity of the Insertion Sort algorithm, if the inputs are restricted to permutations of $1 \dots n$ with at most n inversions?

(A) $\Theta(n^2)$ (B) $\Theta(n \log n)$ (C) $\Theta(n^{1.5})$ (D) $\Theta(n)$

63. A data structure is required for storing a set of integers such that each of the following operations can be done in $O(\log n)$ time, where n is the number of elements in the set.

- I. Deletion of the smallest element
II. Insertion of an element if it is not already present in the set

Which of the following data structures can be used for this purpose?

- (A) A heap can be used but not a balanced binary search tree
(B) A balanced binary search tree can be used but not a heap
(C) Both balanced binary search tree and heap can be used
(D) Neither balanced binary search tree nor heap can be used

64. Let \mathbf{S} be a stack of size $n \geq 1$. Starting with the empty stack, suppose we push the first n natural numbers in sequence, and then perform n pop operations. Assume that Push and Pop operations take X seconds each, and Y seconds elapse between the end of one such stack operation and the start of the next operation. For $m \geq 1$, define the stack-life of m as the time elapsed from the end of Push(m) to the start of the pop operation that removes m from \mathbf{S} . The average stack-life of an element of this stack is

(A) $n(X + Y)$ (B) $3Y + 2X$ (C) $n(X + Y) - X$ (D) $Y + 2X$

65. Consider the following 2-3-4 tree (i.e., B-tree with a minimum degree of two) in which each data item is a letter. The usual alphabetical ordering of letters is used in constructing the tree.

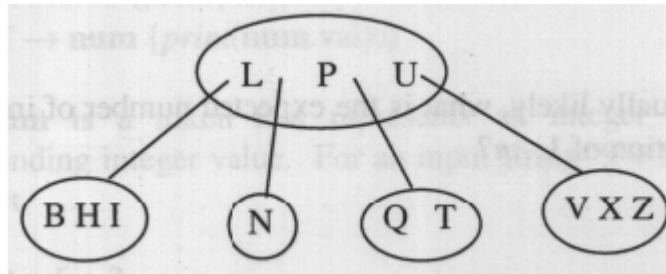

What is the result of inserting G in the above tree?

(A)

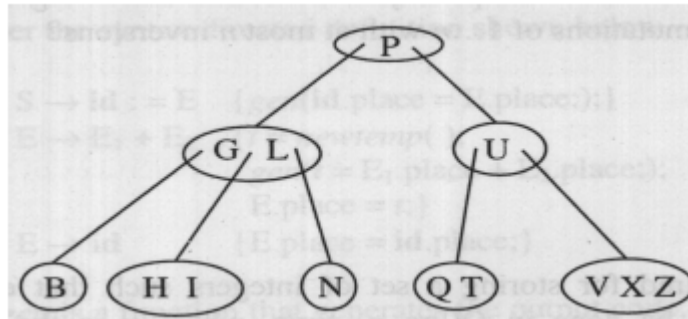

(B)

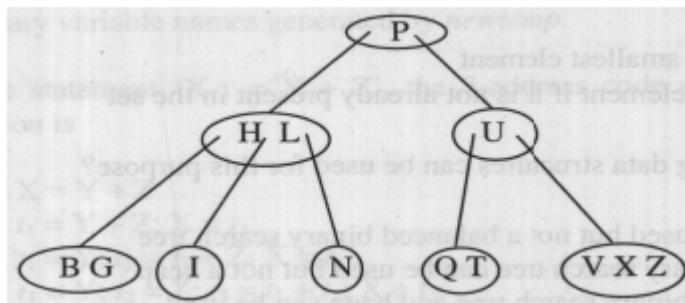

(C)

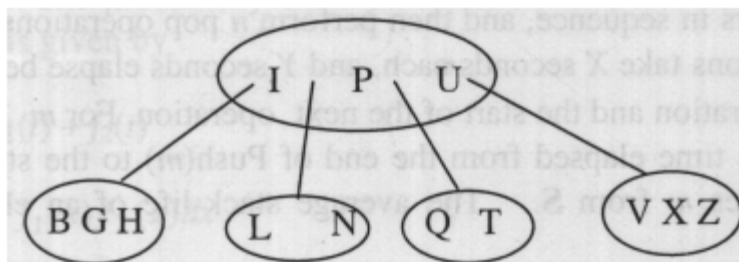

(D) None of the above

66. The cube root of a natural number n is defined as the largest natural number m such that $m^3 \leq n$. The complexity of computing the cube root of n (n is represented in binary notation) is
- (A) $O(n)$ but not $O(n^{0.5})$
 - (B) $O(n^{0.5})$ but not $O((\log n)^k)$ for any constant $k > 0$
 - (C) $O((\log n)^k)$ for some constant $k > 0$, but not $O((\log \log n)^m)$ for any constant $m > 0$
 - (D) $O((\log \log n)^k)$ for some constant $k > 0.5$, but not $O((\log \log n)^{0.5})$

67. Let $G = (V, E)$ be an undirected graph with a subgraph $G_1 = (V_1, E_1)$. Weights are assigned to edges of G as follows.

$$\omega(e) = \begin{cases} 0 & \text{if } e \in E_1 \\ 1 & \text{otherwise} \end{cases}$$

A single-source shortest path algorithm is executed on the weighted graph (V, E, ω) with an arbitrary vertex v_1 of V_1 as the source. Which of the following can always be inferred from the path costs computed?

- (A) The number of edges in the shortest paths from v_1 to all vertices of G
 - (B) G_1 is connected
 - (C) V_1 forms a clique in G
 - (D) G_1 is a tree
68. What is the weight of a minimum spanning tree of the following graph?

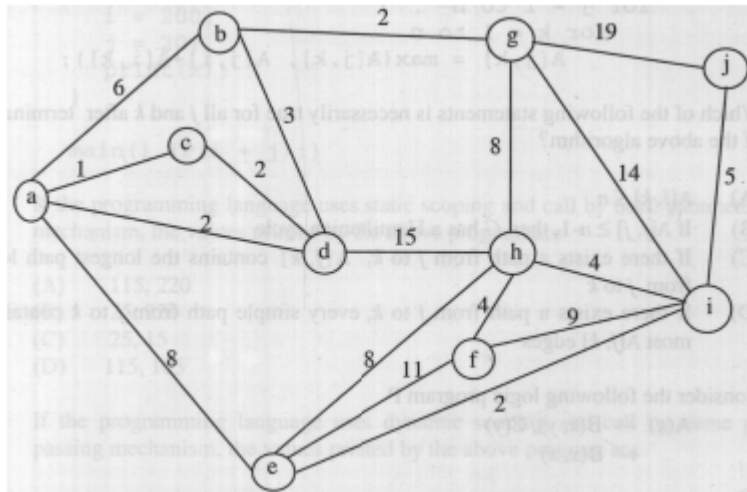

- (A) 29
- (B) 31
- (C) 38
- (D) 41

69. The following are the starting and ending times of activities A, B, C, D, E, F, G and H respectively in chronological order: " $a_s b_s c_s a_e d_s c_e e_s f_s b_e d_e g_s e_e f_e h_s g_e h_e$ ". Here, x_s denotes the starting time and x_e denotes the ending time of activity X. We need to schedule the activities in a set of rooms available to us. An activity

can be scheduled in a room only if the room is reserved for the activity for its entire duration. What is the minimum number of rooms required?

- (A) 3 (B) 4 (C) 5 (D) 6

70. Let $G = (V, E)$ be a directed graph with n vertices. A path from v_i to v_j in G is a sequence of vertices $(v_i, v_{i+1}, \dots, v_j)$ such that $(v_k, v_{k+1}) \in E$ for all k in i through $j - 1$. A simple path is a path in which no vertex appears more than once.

Let A be an $n \times n$ array initialized as follows.

$$A[j, k] = \begin{cases} 1 & \text{if } (j, k) \in E \\ 0 & \text{otherwise} \end{cases}$$

Consider the following algorithm.

for $i = 1$ to n

 for $j = 1$ to n

 for $k = 1$ to n

$$A[j, k] = \max(A[j, k], A[j, i] + A[i, k]);$$

Which of the following statements is necessarily true for all j and k after termination of the above algorithm?

- (A) $A[j, k] \leq n$
 (B) If $A[j, j] \geq n - 1$, then G has a Hamiltonian cycle
 (C) If there exists a path from j to k , $A[j, k]$ contains the longest path length from j to k
 (D) If there exists a path from j to k , every simple path from j to k contains at most $A[j, k]$ edges

71. Consider the following logic program P

$A(x) \leftarrow B(x, y), C(y)$

$\leftarrow B(x, x)$

Which of the following first order sentences is equivalent to P?

- (A) $(\forall x) [(\exists y) [B(x, y) \wedge C(y)] \Rightarrow A(x)] \wedge \neg(\exists x)[B(x, x)]$
 (B) $(\forall x) [(\forall y) [B(x, y) \wedge C(y)] \Rightarrow A(x)] \wedge \neg(\exists x)[B(x, x)]$
 (C) $(\forall x) [(\exists y) [B(x, y) \wedge C(y)] \Rightarrow A(x)] \vee \neg(\exists x)[B(x, x)]$
 (D) $(\forall x) [(\forall y) [B(x, y) \wedge C(y)] \Rightarrow A(x)] \wedge (\exists x)[B(x, x)]$

72. The following resolution rule is used in logic programming.

Derive clause $(P \vee Q)$ from clauses $(P \vee R), (Q \vee \neg R)$

Which of the following statements related to this rule is FALSE?

- (A) $((P \vee R) \wedge (Q \vee \neg R)) \Rightarrow (P \vee Q)$ is logically valid
 (B) $(P \vee Q) \Rightarrow ((P \vee R) \wedge (Q \vee \neg R))$ is logically valid
 (C) $(P \vee Q)$ is satisfiable if and only if $(P \vee R) \wedge (Q \vee \neg R)$ is satisfiable
 (D) $(P \vee Q) \Rightarrow \text{FALSE}$ if and only if both P and Q are unsatisfiable

The following information pertains to 73-74:

The following program fragment is written in a programming language that allows global variables and does not allow nested declarations of functions.

```
global int i = 100, j = 5;
void P(x) {
    int i = 10;
    print(x + 10);
    i = 200;
    j = 20;
    print (x);
}
main() {P(i + j);}
```

73. If the programming language uses static scoping and call by need parameter passing mechanism, the values printed by the above program are
(A) 115, 220 (B) 25, 220 (C) 25, 15 (D) 115, 105
74. If the programming language uses dynamic scoping and call by name parameter passing mechanism, the values printed by the above program are
(A) 115, 220 (B) 25, 220 (C) 25, 15 (D) 115, 105
75. Consider the following class definitions in a hypothetical Object Oriented language that supports inheritance and uses dynamic binding. The language should not be assumed to be either Java or C++, though the syntax is similar.

```
Class P {
    void f(int i) {
        print(i);
    }
}
Class Q subclass of P {
    void f(int i) {
        print(2*i);
    }
}
```

Now consider the following program fragment:

```
Px = new Q()
Qy = new Q();
Pz = new Q();
x.f(1); ((P)y).f(1); z.f(1);
```

Here ((P)y) denotes a typecast of y to P. The output produced by executing the above program fragment will be

- (A) 1 2 1 (B) 2 1 1 (C) 2 1 2 (D) 2 2 2

76. Which of the following is NOT an advantage of using shared, dynamically linked libraries as opposed to using statically linked libraries?
- (A) Smaller sizes of executable files
 - (B) Lesser overall page fault rate in the system
 - (C) Faster program startup
 - (D) Existing programs need not be re-linked to take advantage of newer versions of libraries
77. A uni-processor computer system only has two processes, both of which alternate 10 ms CPU bursts with 90 ms I/O bursts. Both the processes were created at nearly the same time. The I/O of both processes can proceed in parallel. Which of the following scheduling strategies will result in the *least* CPU utilization (over a long period of time) for this system?
- (A) First come first served scheduling
 - (B) Shortest remaining time first scheduling
 - (C) Static priority scheduling with different priorities for the two processes
 - (D) Round robin scheduling with a time quantum of 5 ms

The following information pertains to Q.78-79:

A processor uses 2-level page tables for virtual to physical address translation. Page tables for both levels are stored in the main memory. Virtual and physical addresses are both 32 bits wide. The memory is byte addressable. For virtual to physical address translation, the 10 most significant bits of the virtual address are used as index into the first level page table while the next 10 bits are used as index into the second level page table. The 12 least significant bits of the virtual address are used as offset within the page. Assume that the page table entries in both levels of page tables are 4 bytes wide. Further, the processor has a translation look-aside buffer (TLB), with a hit rate of 96%. The TLB caches recently used virtual page numbers and the corresponding physical page numbers. The processor also has a physically addressed cache with a hit rate of 90%. Main memory access time is 10 ns, cache access time is 1 ns, and TLB access time is also 1 ns.

78. Assuming that no page faults occur, the average time taken to access a virtual address is approximately (to the nearest 0.5 ns)
- (A) 1.5 ns
 - (B) 2 ns
 - (C) 3 ns
 - (D) 4 ns
79. Suppose a process has only the following pages in its virtual address space: two contiguous code pages starting at virtual address 0x00000000, two contiguous data pages starting at virtual address 0x00400000, and a stack page starting at virtual address 0xFFFFF000. The amount of memory required for storing the page tables of this process is
- (A) 8 KB
 - (B) 12 KB
 - (C) 16 KB
 - (D) 20 KB

The following information pertains to Q.80-81:

Suppose we want to synchronize two concurrent processes P and Q using binary semaphores S and T. The code for the processes P and Q is shown below.

Process P:	Process Q:
while (1) {	while (1) {
W:	Y:
print '0';	print '1';
print '0';	print '1';
X:	Z:
}	}

Synchronization statements can be inserted only at points W, X, Y, and Z

80. Which of the following will always lead to an output starting with '001100110011'?
- (A) P(S) at W, V(S) at X, P(T) at Y, V(T) at Z, S and T initially 1
 - (B) P(S) at W, V(T) at X, P(T) at Y, V(S) at Z, S initially 1, and T initially 0
 - (C) P(S) at W, V(T) at X, P(T) at Y, V(S) at Z, S and T initially 1
 - (D) P(S) at W, V(S) at X, P(T) at Y, V(T) at Z, S initially 1, and T initially 0
81. Which of the following will ensure that the output string never contains a substring of the form $01n0$ or $10n1$ where n is odd?
- (A) P(S) at W, V(S) at X, P(T) at Y, V(T) at Z, S and T initially 1
 - (B) P(S) at W, V(T) at X, P(T) at Y, V(S) at Z, S and T initially 1
 - (C) P(S) at W, V(S) at X, P(S) at Y, V(S) at Z, S initially 1
 - (D) V(S) at W, V(T) at X, P(S) at Y, P(T) at Z, S and T initially 1
82. The subnet mask for a particular network is 255.255.31.0. Which of the following pairs of IP addresses could belong to this network?
- (A) 172.57.88.62 and 172.56.87.233
 - (B) 10.35.28.2 and 10.35.29.4
 - (C) 191.203.31.87 and 191.234.31.88
 - (D) 128.8.129.43 and 128.8.161.55
83. A 2km long broadcast LAN has 10^7 bps bandwidth and uses CSMA/CD. The signal travels along the wire at 2×10^8 m/s. What is the minimum packet size that can be used on this network?
- (A) 50 bytes
 - (B) 100 bytes
 - (C) 200 bytes
 - (D) None of the above
84. Host A is sending data to host B over a full duplex link. A and B are using the sliding window protocol for flow control. The send and receive window sizes are 5 packets each. Data packets (sent only from A to B) are all 1000 bytes long and the transmission time for such a packet is $50 \mu\text{s}$. Acknowledgement packets (sent only from B to A) are very small and require negligible transmission time. The

87. Consider three data items D1, D2, and D3, and the following execution schedule of transactions T1, T2, and T3. In the diagram, R(D) and W(D) denote the actions reading and writing the data item D respectively.

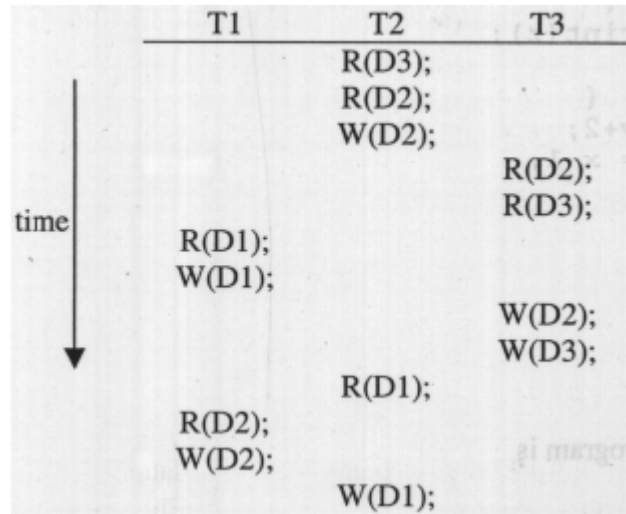

- Which of the following statements is correct?
- (A) The schedule is serializable as T2; T3; T1
 (B) The schedule is serializable as T2; T1; T3
 (C) The schedule is serializable as T3; T2; T1
 (D) The schedule is not serializable
88. In the following C program fragment, j , k , n and TwoLog_n are integer variables, and A is an array of integers. The variable n is initialized to an integer ≥ 3 , and TwoLog_n is initialized to the value of $2 * \lceil \log_2(n) \rceil$

```

for (k=3; k <= n; k++)
    A[k] = 0;
for (k=2; k <= TwoLog_n; k++)
    for (j=k+1; j <= n; j++)
        A[j] = A[j] || (j%k);
for (j=3; j <= n; j++)
    if (!A[j]) printf("%d ",j);

```

The set of numbers printed by this program fragment is

- (A) $\{m | m \leq n, (\exists i)[m=i!]\}$
 (B) $\{m | m \leq n, (\exists i)[m=i^2]\}$
 (C) $\{m | m \leq n, m \text{ is prime}\}$
 (D) $\{\}$

89. Consider the C program shown below.

```
#include <stdio.h>
#define print(x) printf("%d ", x)
int x;
void Q(int z) {
    z += x; print(z);
}
void P(int *y) {
    int x = *y+2;
    Q(x); *y = x-1;
    print(x);
}
main(void) {
    x = 5;
    P(&x)
    print(x);
}
```

The output of this program is

- (A) 12 7 6 (B) 22 12 11 (C) 14 6 6 (D) 7 6 6
90. Consider the function f defined below.

```
struct item {
    int data;
    struct item * next;
};
int f(struct item *p) {
    return ((p == NULL) || (p ->next == NULL) ||
        ((p->data <= p -> next -> data) &&
        f(p-> next)));
}
```

For a given linked list p, the function f returns 1 if and only if

- (A) the list is empty or has exactly one element
(B) the elements in the list are sorted in non-decreasing order of data value
(C) the elements in the list are sorted in non-increasing order of data value
(D) not all elements in the list have the same data value