



MADE EASY

India's Best Institute for IES, GATE & PSUs

ESE 2019

Preliminary Examination

Detailed Solutions of
General Studies and
Engineering Aptitude
(Set-A)

[Scroll down for detailed solutions](#)

www.madeeasy.in

Corporate Office: 44-A/1, Kalu Sarai, New Delhi - 110016 | Ph: 011-45124612, 9958995830

Delhi | Hyderabad | Noida | Bhopal | Jaipur | Lucknow | Indore | Pune | Bhubaneswar | Kolkata | Patna



MADE EASY

India's Best Institute for IES, GATE & PSUs

Mains Exclusive Batches for ESE 2019 Conventional Questions Practice Programme

Commencing from **20th Feb, 2019**

These batches are offered only at **Delhi Centre.**

+

Mains Test Series for ESE 2019 (Offline Mode / Online Mode)

Commencing from **17th Mar, 2019**

Test series will be conducted at **all MADE EASY** centres across India.

Features :

- Very useful to develop numerical solving approach & improving writing skills.
- Special focus on improving answer layout specially for theory questions.
- Classes will be delivered by senior faculties.
- Updated Mains workbook for every subject having varied practice question sets.
- Test series will be conducted on every Sunday in synchronisation with the subject taught in class.
- Discussion on probable questions.
- Comprehensive and in-depth discussion on variety of conventional questions, thus strengthening fundamental concepts.

Batch Details	Course Duration	Class Duration	Test Series
	90 days 300 - 350 hours	5-6 days a week and 6-7 hours a day	Every Sunday

Streams	Batch Code	Batch Commencing Date	Venue (Delhi)	Timing
ME	A	20-Feb-2019	Ghitorni Centre	7:30 AM to 1:30 PM
ME	B	20-Feb-2019	Ghitorni Centre	3:00 PM to 9:00 PM
ME	C	20-Feb-2019	Saket Centre	7:30 AM to 1:30 PM
CE	A	21-Feb-2019	Ignou Road Centre	7:30 AM to 1:30 PM
CE	B	21-Feb-2019	Kalu Sarai Centre	3:00 PM to 9:00 PM
EE	A	22-Feb-2019	Lado Sarai Centre	7:30 AM to 1:30 PM
EE	B	22-Feb-2019	Kalu Sarai Centre	3:00 PM to 9:00 PM
EC	A	22-Feb-2019	Lado Sarai Centre	7:30 AM to 1:30 PM

Program	Ex. MADE EASY Students Enrolled in Postal, Rank Improvement, Mains, GS, Post-GATE, ESE+ GATE, GATE Batches	Non MADE EASY students
Mains Exclusive Batch (Inclusive of ESE-2019 Mains Offline Test Series)	₹ 18,500	₹ 22,500
ESE 2019 Mains Offline Test Series	₹ 2,500	₹ 3,500

All Fees are Inclusive of GST

Hostel facility will be arranged

1. Which one of the following is **not** a component of 'Capital Receipts'?
- (a) Market borrowings including special bonds
 - (b) External loans raised by the Central Government from abroad
 - (c) Receipts from taxes on property and capital transactions
 - (d) Provident Funds (State Provident Funds and Public Provident Fund)

Ans. (c)

The components of Capital Receipts are:

- (i) Recovery of loans and advances
- (ii) Disinvestment
- (iii) Borrowing (domestic and external)
- (iv) Small savings

End of Solution

2. Which one of the following statement is correct with respect to the 'societal development'?
- (a) Behaviour grows into habits, habits into tradition and tradition becomes custom
 - (b) Customs grow into mores and mores grow into custom
 - (c) Behaviours grow into customs and customs grow into traditions
 - (d) Folkways grow into tradition and traditions grow into customs

Ans. (a)

The said option is a normal sequence of behaviour becoming a custom.

End of Solution

3. Which one of the following statement is correct with respect to 'the convergence theory' on social change?
- (a) The societal adaptive culture is changing more slowly
 - (b) As societies become modernized, they begin to resemble one another more closely
 - (c) The developed countries show more growth in social changes than the less developed countries
 - (d) Strong opposition by old people retards the social change

Ans. (b)

The chosen option is one of the defining dictums of the convergence theory on social change.

End of Solution

4. With respect to the conduct and performance of a company, 'perfect competition' refers to
- (a) Large number of small firms producing differentiated products
 - (b) Complete freedom in economic life and absence of rivalry among firms
 - (c) Many companies selling similar products with free entry
 - (d) Sole producer selling a distinct product

Ans. (c)

End of Solution

5. The cheapest method of marketing of securities with the only cost incurred being on sending 'letters of rights' to existing holders is
- (a) Public issue through prospectus method
 - (b) Offer for sale method
 - (c) Rights issue
 - (d) Subscription by inside coterie method

Ans. (c)

End of Solution

6. 'Fiscal policy' means
- (a) Balancing the revenue collection and expenditure
 - (b) Establishing equilibrium between demand and supply of goods and services
 - (c) Use of taxation, public borrowing and public expenditure by Government for purposes of 'stabilization' or 'development'
 - (d) Deficiency as an instrument of growth

Ans. (c)

In economics, fiscal policy is the use of government revenue collection (mainly taxes) and expenditure (spending) to influence the economy.

End of Solution

7. Which of the following come under the offerings of 'MUDRA' Bank?
- 1. Portfolio Credit Guarantee
 - 2. Credit for large industries
 - 3. MUDRA Card
 - 4. Credit Enhancement

Select the correct answer using the codes given below:

- (a) 1, 2 and 3 only
- (b) 1, 3 and 4 only
- (c) 1, 2 and 4 only
- (d) 2, 3 and 4 only

Ans. (b)

MUDRA Bank has been established to refinance Micro Finance Institutions (MFIs) through the Pradhan Mantri Mudra Yojana. MUDRA Bank will work with coordinators at the national, state and regional levels. Additionally, it will also work with last mile financiers (LMFs) of micro businesses at the regional levels.

Source: MADE EASY Annual Current Affairs Magazine, 2018 (Pg. No. 34)

End of Solution

8. Which of the following is/are the key reasons for encouraging start up Entrepreneurship?
- 1. Innovations
 - 2. Focusing on service industry
 - 3. Bringing the values of proactivity into the society

Select the correct answer using the codes given below:

- (a) 1 only (b) 2 only
(c) 1 and 3 only (d) 1, 2 and 3

Ans. (c)

The key reasons for encouraging start up entrepreneurship are innovations and bringing the values of proactivity into the society.

Source: MADE EASY Annual Current Affairs Magazine, 2018 (Pg. No. 33)

End of Solution

9. Which of the following are the main objectives of Gold Monetization Scheme launched in the country?

1. To monetize gold holdings in the country
2. To increase export of gold from the country
3. To reduce India's import bill
4. To meet the targets of reduction in fiscal deficit

Select the correct answer using the codes given below:

- (a) 1 and 4 only (b) 2 and 4 only
(c) 2 and 3 only (d) 1 and 3 only

Ans. (d)

The purpose of Gold Monetization Scheme (GMS) is to mobilize unutilized gold from individuals, households and institutions and make them available to gold-based industries including jewellers.

Its primary objectives are to reduce dependence on imported gold and recycle the unutilized gold in the country.

Source: MADE EASY Annual Current Affairs Magazine, 2018 (Pg. No. 41)

End of Solution

10. A person travelled by car 70 km towards north to A then covered 30 km turning left to B. Again he turned towards left and travelled 110 km to C. Then he cycled at the rate of 10 km/hour towards the starting point. The time taken by him to reach the starting point from C will be

- (a) 3 hours (b) 5 hours
(c) 7 hours (d) 21 hours

Ans. (b)

$$\begin{aligned} \text{Time taken} &= \frac{\text{Distance}}{\text{Speed}} \\ &= \frac{50 \text{ km}}{10 \text{ km/hr}} \\ &= 5 \text{ hr} \end{aligned}$$

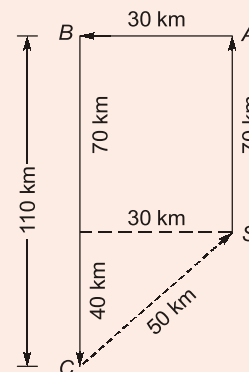

End of Solution

11. A student purchases some books for Rs. 1600. If he had bought 8 more books for the same amount, each book would cost Rs. 10 less. The number of books he buys is
- (a) 30 (b) 32
(c) 34 (d) 36

Ans. (b)

Let x be the number of books

Using options $\frac{1600}{x} - \frac{1600}{x+8} = 10$

$$x = 32$$

Alternatively

$$32 \times 50 = 40 \times 40$$

End of Solution

12. A hemisphere depression is cutout from one face of the cubical wooden block such that the radius r of the hemisphere is equal to half of the edge of the cube. What will be the surface area of the remaining solid?
- (a) $2r^2(\pi + 24)$ (b) $r^2(\pi + 24)$
(c) $2r^2(\pi + 36)$ (d) $r^2(\pi + 36)$

Ans. (b)

Required area = Trough area of hemisphere [A]

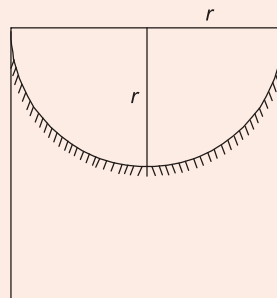

+ Area of five remaining faces of cube [B]

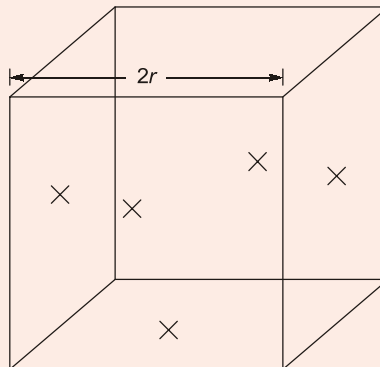

+ Left out area on the face of cube after taking out hemisphere [C]

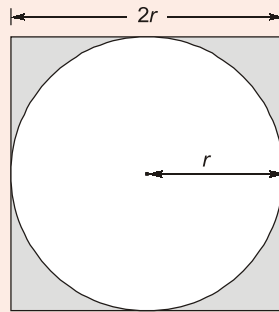

$$A = 2\pi r^2$$

$$B = 5 \times (2r)^2 = 20r^2$$

$$C = 4r^2 - \pi r^2$$

$$\text{Required area} = A + B + C$$

$$= \pi r^2 + 24r^2$$

$$= r^2 (\pi + 24)$$

End of Solution

13. A rod of length l is to be divided into two parts, such that if 5 times the smaller portion is added to half of the larger portion, it will always be less than l . This can be achieved by taking length of the larger portion more than

(a) $\frac{9}{10}l$

(b) $\frac{7}{8}l$

(c) $\frac{6}{7}l$

(d) $\frac{5}{6}l$

Ans. (a)

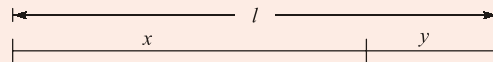

$$x + y = l$$

$$y = l - x$$

$$5y + \frac{x}{2} < l$$

$$5l - 5x + \frac{x}{2} < l$$

$$-\frac{9}{2}x < -4l$$

$$x > \frac{8}{9}l$$

Only option greater than $\frac{8}{9}l$ is option (a)

General Studies & Engineering Aptitude Batches for ESE 2020 (Preliminary Examination)



MADE EASY
India's Best Institute for IES, GATE & PSUs

Syllabus Covered

1. Current issues of national and international importance relating to social economic and industrial development.
2. Engineering Aptitude covering Logical reasoning and Analytical ability.
3. Engineering Mathematics and Numerical Analysis.
4. General Principles of Design, Drawing, Importance of Safety.
5. Standards and Quality practices in production, construction, maintenance and services.
6. Basic of Energy and Environment : Conservation, Environmental pollution and degradation, Climate Change, Environmental impact assessment.
7. Basic of Project Management.
8. Basics of Material Science and Engineering.
9. Information and Communication Technologies (ICT) based tools and their applications in Engineering such as networking, e-governance and technology based education.
10. Ethics and values in engineering profession.

Course Duration

Regular Batches : 2.5 months
Weekend Batches : 4 months

Timings

Regular : 6 to 7 days a week and 4-6 hours a day
Weekend : Sat, Sun & public holiday, 8 hours each day

Teaching Hours

250-300 hours

Batch Type	Commencing Dates	Venue	Timing
Regular Batch	20 th Feb, 2019	Ghitorni (Delhi)	8:00 AM to 12:00 PM
Weekend Batch	24 th Feb, 2019	Ghitorni (Delhi)	8:00 AM to 5:00 PM
Weekend Batch	24 th Feb, 2019	Noida Centre	8:00 AM to 5:00 PM

Fee Structure

Non-MADE EASY Students	Ex. MADE EASY Students
	Enrolled in Postal, Rank Improvement, Mains, GS, GATE, GATE + ESE Batches
<p>₹ 25,000</p> <ul style="list-style-type: none"> • GS & Engg Aptitude Books will be issued. 	<p>₹ 18,000</p> <ul style="list-style-type: none"> • GS & Engg Aptitude Books will NOT be issued. • Interested students can avail books by paying the fee of Rs. 2,000/-

Corporate office : 44-A/1, Kalu Sarai, New Delhi - 1100 16 ☎ 011-45124612, 9958995830

Noida office : D-28, Sector - 63, Noida, Uttar Pradesh - 201301 ☎ 0120-6524612, 08860378009

**ADMISSION
OPEN**

Alternatively

In option (a), let length of rod = 10

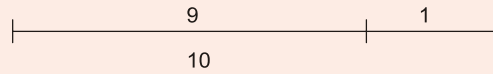

$$5 + 4.5 = 9.5 < 10$$

In option (b) let length of rod = 8 and likewise.

Only option (a) satisfies.

End of Solution

14. Which of the following conditions hold good for a train which crosses the bridge of length l in time t_1 and crosses another bridge of length $\frac{l}{2}$ in time t_2 ?

1. $t_2 = \frac{t_1}{2}$
2. $2t_2 > t_1$
3. $t_2 < \frac{t_1}{2}$
4. Speed of train is $\frac{l}{10}$ if $t_1 - t_2 = 5$

Select the correct answer using the codes given below:

- | | |
|------------------|------------------|
| (a) 1 and 4 only | (b) 2 and 4 only |
| (c) 1 and 3 only | (d) 2 and 3 only |

Ans. (b)

Let the length of train = x

Length of the bridge = l

Speed of train = s



$$\frac{l+x}{s} = t_1 \qquad \dots(i)$$

$$\frac{\frac{l}{2}+x}{s} = t_2 \qquad \dots(ii)$$

Option (1)

If $t_2 = \frac{t_1}{2}$

Replacing eq. (i) and (ii)

$$\frac{\frac{l}{2}+x}{s} = \frac{1}{2} \left(\frac{l+x}{s} \right)$$

$$2 \left(\frac{l}{2} + x \right) = (l+x)$$

$$x = 0$$

(Not possible)

Length of train must be greater than zero.
Therefore option (1) is false.

Option (2)

$$2(t_2) > t_1$$

$$\frac{2\left(\frac{l}{2} + x\right)}{s} > \frac{l+x}{s}$$

$$l + 2x > l + x$$

$$x > 0$$

Length of train has to be positive.
Therefore option (2) is true.

Option (3)

$$t_2 < \frac{t_1}{2}$$

$$\frac{\frac{l}{2} + x}{s} < \frac{1}{2} \left(\frac{l+x}{s} \right)$$

$$2\left(\frac{l}{2} + x\right) < l + x$$

$$x < 0$$

Length of train cannot be negative.
Therefore option (3) is false.

Option (4)

$$s = \frac{l}{10} \text{ if } t_1 - t_2 = 5$$

$$\frac{l+x}{s} = t_1 \quad \dots(i)$$

$$\frac{\frac{l}{2} + x}{s} = t_2 \quad \dots(ii)$$

Replacing $s = \frac{l}{10}$ in eq. (i) and (ii)

$$\frac{l+x}{\frac{l}{10}} = t_1 \quad \dots(iii)$$

$$\Rightarrow x = \frac{lt_1 - 10l}{10} \quad \dots(\text{iv})$$

$$\frac{\frac{l}{2} + x}{\frac{l}{10}} = t_2 \quad \dots(\text{v})$$

$$\Rightarrow x = \frac{lt_2 - 5l}{10} \quad \dots(\text{vi})$$

Eq. (iv) = eq. (vi) solve $t_1 - t_2 = 5$
Option (2) and (4) are true.

End of Solution

15. A tourist covers half of his journey by train at 60 km/h, half of the remainder by bus at 30 km/h and the rest by cycle at 10 km/h. Average speed of the tourist during the journey is
- (a) 36 km/h (b) 33 km/h
(c) 24 km/h (d) 18 km/h

Ans. (c)

Let total distance = D

$$\text{Average speed} = \frac{\text{Total distance}}{\text{Total time}} = \left(\frac{\frac{D}{\frac{D}{60} + \frac{D}{30} + \frac{D}{10}}}{\frac{D}{60} + \frac{D}{30} + \frac{D}{10}} \right) = 24 \text{ kmph}$$

End of Solution

16. In a lake, the tip of a bud of lotus is seen 10 cm above the surface of water. Forced by the wind, it gradually moved, and just submerged at a distance of 30 cm. The depth of water at the root of the lotus plant will be
- (a) 40 cm (b) 50 cm
(c) 60 cm (d) 70 cm

Ans. (a)

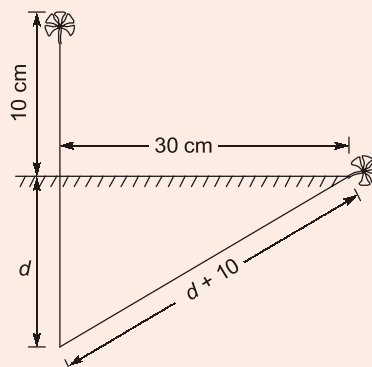

Applying Pythagoras Theorem

$$d^2 + 30^2 = (d + 10)^2$$

Using options, $d = 40$ (Pythagorean Triplet)

End of Solution

17. A man sold a chair and a table together for Rs. 7,600, thereby making a profit of 25% on the chair and 10% on the table. By selling them together for Rs. 7,500 he would make a profit of 10% on the chair and 20% on the table. Then the cost price of chair and table will be

- (a) Rs. 3000 and Rs. 4000 (b) Rs. 3500 and Rs. 4000
(c) Rs. 3000 and Rs. 3500 (d) Rs. 3500 and Rs. 3500

Ans. (c)

Using options

$$3000 \times 1.25 + 3500 \times 1.1 = 7600$$

$$3000 \times 1.10 + 3500 \times 1.20 = 7500$$

End of Solution

18. In two concentric circles, a chord length 80 cm of larger circle becomes a tangent to the smaller circle whose radius is 9 cm. The radius of the larger circle will be

- (a) 13 cm (b) 41 cm
(c) 52 cm (d) 75 cm

Ans. (b)

$$R = \sqrt{40^2 + 9^2}$$

$$R = 41$$

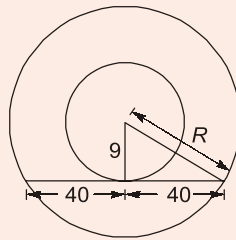
**End of Solution**

19. Professionals who breach the 'duty of care' are liable for injuries their negligence causes. This liability is commonly referred to as

- (a) Professional offense (b) Professional negligence
(c) Professional misdeed (d) Professional malpractice

Ans. (b)

The above given statement forms the definition of 'professional negligence'.

End of Solution

20. Information used in a business, generally unknown to the public, that the company has taken strong measures to keep confidential is called
- (a) A patent (b) A copyright
(c) A trade secret (d) A trade mark

Ans. (c)
The above given statement is the definition of a 'trade secret'.

End of Solution

21. A committee of 4 is to be formed from among 4 girls and 5 boys. What is the probability that the committee will have number of boys less than number of girls?
- (a) $\frac{2}{9}$ (b) $\frac{4}{9}$
(c) $\frac{4}{5}$ (d) $\frac{1}{6}$

Ans. (d)
Total number of ways to select 4 person out of 9 persons is 9C_4 .
For the committee to have number of boys less than number of girls means, the number of girls is 3 and number of boys is 1 (or) number of girls is 4 and number of boys is 0.

This can be done is ${}^4C_3 \times {}^5C_1 + {}^4C_4 \times {}^5C_0$

$$\therefore \text{Required probability} = \frac{{}^4C_3 \times {}^5C_1 + {}^4C_4 \times {}^5C_0}{{}^9C_4} = \frac{1}{6}$$

Source: Similar Problem : MADE EASY Workbook 2019, Pg. 35 (Problem No. 10)

End of Solution

22. The solution of initial value problem; $\frac{\partial u}{\partial x} = 2\frac{\partial u}{\partial t} + u$, where $u(x, 0) = 6e^{-3x}$ is
- (a) $u = 6e^{-3x+t}$ (b) $u = 6e^{-(2x+2t)}$
(c) $u = 6e^{-(3x+2t)}$ (d) $u = 6e^{-(3x+t)}$

Ans. (c)

$$\frac{\partial u}{\partial x} = 2\frac{\partial u}{\partial t} + u \quad \dots(i)$$

$$u(x, 0) = 6e^{-3x}$$

Separation of variables

Let, $u(x, t) = X(x)T(t)$

$$u_x = X' T$$

$$u_t = XT'$$

Put in eq. (i)

$$X'T = 2XT' + XT$$

Divide by XT

$$\frac{X'}{X} = \frac{2T'}{T} + 1 = k$$

$$X' = kX$$

$$(D - k)X = 0$$

AE: $m - k = 0$

$$m = k$$

$$X = C_1 e^{kx}$$

$$2T' = (k - 1)T$$

$$2T' - (k - 1)T = 0$$

AE: $2m - (k - 1) = 0$

$$m = \frac{(k-1)}{2}$$

$$T = C_2 e^{\frac{(k-1)}{2}t}$$

$$u(x, t) = XT$$

$$u(x, t) = C_1 C_2 e^{kx + \frac{(k-1)}{2}t}$$

$$u(x, 0) = C_1 C_2 e^{kx} = 6e^{-3x}$$

\therefore $C_1 C_2 = 6$
 $k = -3$

$$u(x, t) = 6e^{-3x-2t}$$

$$u(x, t) = 6e^{-(3x+2t)}$$

Source: MADE EASY Workbook 2019 (Problem No. 15)

End of Solution

23. Polar form of the Cauchy-Reimann equations is

(a) $\frac{\partial u}{\partial r} = r \frac{\partial v}{\partial \theta}$ and $\frac{\partial v}{\partial r} = -r \frac{\partial u}{\partial \theta}$

(b) $\frac{\partial u}{\partial r} = \frac{1}{r} \frac{\partial v}{\partial \theta}$ and $\frac{\partial v}{\partial r} = -\frac{1}{r} \frac{\partial u}{\partial \theta}$

(c) $\frac{\partial u}{\partial r} = \frac{1}{r} \frac{\partial v}{\partial \theta}$ and $\frac{\partial v}{\partial r} = -r \frac{\partial u}{\partial \theta}$

(d) $\frac{\partial u}{\partial r} = r \frac{\partial v}{\partial \theta}$ and $\frac{\partial v}{\partial r} = -\frac{1}{r} \frac{\partial u}{\partial \theta}$

Ans. (b)

We have, $f(re^{i\theta}) = u + iv$... (i)

Differentiating (i) partially w.r.t. r

$$r'(re^{i\theta})e^{i\theta} = \frac{\partial u}{\partial r} + i \frac{\partial v}{\partial r}$$
 ... (ii)

Differentiating (i) partially w.r.t. θ

$$r'(re^{i\theta})ire^{i\theta} = \frac{\partial u}{\partial \theta} + i\frac{\partial v}{\partial \theta} \quad \dots(iii)$$

From eq. (ii) and (iii)

$$ir\left[\frac{\partial u}{\partial r} + i\frac{\partial v}{\partial r}\right] = \frac{\partial u}{\partial \theta} + i\frac{\partial v}{\partial \theta}$$

Comparing on both sides, we get,

$$\frac{\partial u}{\partial r} = \frac{1}{r}\frac{\partial v}{\partial \theta}$$

$$\frac{\partial v}{\partial r} = -\frac{1}{r}\frac{\partial u}{\partial \theta}$$

Source: MADE EASY Theory Book (Pg. 282)

End of Solution

24. If $f(z)$ has a pole of order n at $z = a$, then Residue of function $f(z)$ at a is

$$(a) \text{ Res } f(a) = \frac{1}{(n)!} \left\{ \frac{d^{n-1}}{dz^{n-1}} ((z-a)^{n-1} f(z)) \right\}_{z=a}$$

$$(b) \text{ Res } f(a) = \frac{1}{(n-1)!} \left\{ \frac{d^{n-1}}{dz^{n-1}} ((z-a)^{n-1} f(z)) \right\}_{z=a}$$

$$(c) \text{ Res } f(a) = \frac{1}{(n)!} \left\{ \frac{d^{n-1}}{dz^{n-1}} ((z-a)^n f(z)) \right\}_{z=a}$$

$$(d) \text{ Res } f(a) = \frac{1}{(n-1)!} \left\{ \frac{d^{n-1}}{dz^{n-1}} ((z-a)^n f(z)) \right\}_{z=a}$$

Ans. (d)

If $f(z)$ is a pole of order n at $z = a$

$$\text{Then } \text{Res } f(z) = \lim_{z \rightarrow a} \frac{1}{(n-1)!} \frac{d^{n-1}}{dz^{n-1}} ((z-a)^n f(z))$$

Source: MADE EASY Theory Book (Pg. 293)

End of Solution

RANK IMPROVEMENT BATCHES for ESE 2020 & GATE 2020 at Delhi Centre



MADE EASY
India's Best Institute for IES, GATE & PSUs

Rank Improvement Batches are designed with a motive to provide more practice to students by focusing on numerical solving. Supplemented with exclusive workbooks having variety of questions, makes these batches a complete package to help repeater aspirants who have taken classroom coaching or prepared themselves for these exams to fill the gap and get ready for the next.

FEATURES :

- Comprehensive problem solving sessions
- Smart techniques to solve problems
- Techniques to improve accuracy & speed
- Systematic & cyclic revision of all subjects
- Doubt clearing sessions
- Weekly class tests for performance improvement
- Inclusive of interview guidance for PSUs
- Specially designed workbooks for technical subjects

ELIGIBILITY :

- Ex. MADE EASY students who have undergone classroom coaching from any centre of MADE EASY
- Students who have undergone classroom coaching from any other institute
- Qualified in GATE exam
- Qualified in ESE (Pre/Mains) written exam
- Qualified in any PSU exam
- M. Tech from reputed colleges

Streams	Timing	Date	Venue
CE	5:00 PM to 9:00 PM	20 th May, 2019	Saket-2
ME	5:00 PM to 9:00 PM	20 th May, 2019	Ghitorni
EE	5:00 PM to 9:00 PM	21 st May, 2019	Lado Sarai-1
EC	5:00 PM to 9:00 PM	21 st May, 2019	Lado Sarai-2

SYLLABUS COVERED

Complete GATE syllabus &
Technical syllabus of ESE

COURSE DURATION

Approximately 5 months
450-475 teaching hours

CLASS TIMING

5-6 days a week
4 hours a day

Note : These batches will be focusing on solving problems and doubt clearing sessions. Therefore if a student is weak in basic concepts & fundamentals then he/she is recommended to join regular classroom course.

Corporate office : 44-A/1, Kalu Sarai, New Delhi - 1100 16 ☎ 011-45124612, 9958995830

ADMISSION OPEN

☎ 011-45124612 | 🌐 www.madeeasy.in

30. Consider the following Repeat Unit Structure:

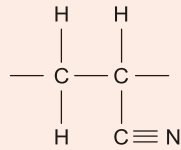

What is the above polymer?

- (a) Poly(amide – imide) (b) Polyacrylonitrile
(c) Polybutadiene (d) Polyethylene

Ans. (b)

The given polymer is polyacrylonitrile.

Source: MADE EASY Class Notes (GS Batch)

Chapter: Polymers, Heading: Copolymers (2nd example)

End of Solution

31. Which of the following measures is/are correct for using Mobile Equipment Working Platform (MEWP)?

1. Tyres are properly inflated and air filled
 2. SWL to be marked in platforms as identification for carrying loads
- (a) 1 only (b) 2 only
(c) Both 1 and 2 (d) Neither 1 nor 2

Ans. (c)

End of Solution

32. Ozone layer present in the atmosphere protects life on earth by not permitting harmful radiations present in the sunlight to penetrate through it. Ozone layer is formed by the reaction of

- (a) Chlorofluorocarbons (CFCs) on oxygen (O_2)
(b) Chlorine (Cl) on oxygen (O_2)
(c) Solar Ultraviolet rays on oxygen (O_2)
(d) Chlorine nitrate ($ClNO_3$) on oxygen (O_2)

Ans. (c)

UV (Ultra violet) rays once fall on the O_2 molecule in stratosphere then O_2 molecule is split into nascent oxygen ($O_2 = O + O$). Nascent oxygen is combined with O_2 molecule and forming ozone (O_3) $\{(O + O_2 = O_3)\}$. Thus, ozone formation is natural phenomena in stratosphere unlike the troposphere.

Source: MADE EASY Theory Book (Basics of Energy & Environment) {Pg. No. 168}

End of Solution

33. The insert command is used in 'Auto CAD' to insert

- (a) Objects in the current file (b) Objects in any file
(c) Blocks in any drawing file (d) Blocks and wblocks in the current drawing

Ans. (d)

Correct statement is “The insert command is used in AUTO CAD to insert blocks and wblocks in the current drawing.

Block is a collection of drawing entities combined so that it can be inserted in current drawing at the required insertion point. A block is valid for insertion only in the current drawing. On pressing insert tab the block related to current drawing are directly displayed as shown.

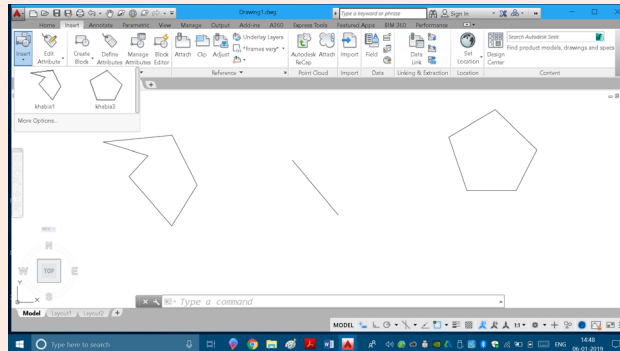

Wblock is a portion of drawing or a complete drawing. To insert a wblock we can press the browse tab in insert menu select the required wblock or a new drawing and then insert it. Only dwg or dxf file can be inserted as shown below.

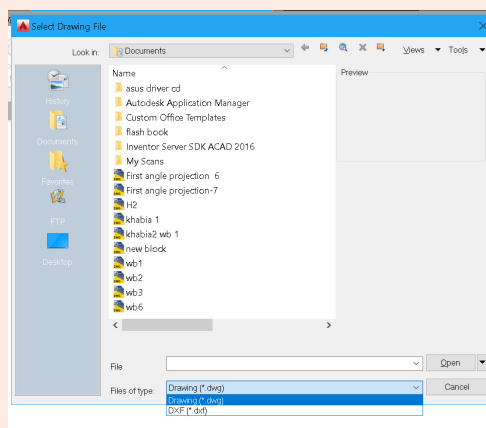
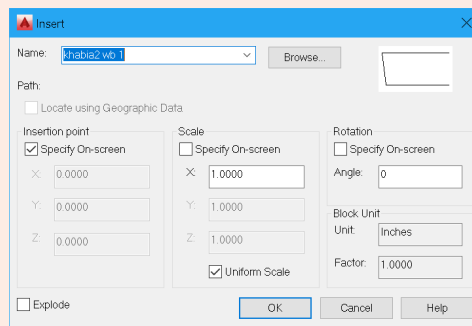

End of Solution

34. A cone resting on its base in horizontal plane (HP) is cut by a plane inclined to the axis and parallel to one of its generators, the sectional view will be
- (a) Ellipse (b) Parabola
(c) Hyperbola (d) Circle

Ans. (b)

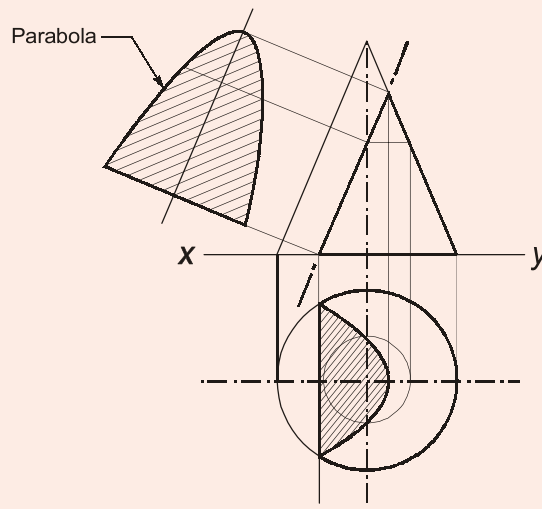

As per definition when a right cone is cut by a cutting plane whose inclination with axis is equal to inclination of generator with axis, then curve produce due to intersection of cutting plane and curved surface of right cone is a parabola. Drawing above further illustrates the definition.

Source: MADE EASY Class Notes, Theory Book (Pg.70) and Workbook (Q.No. 95)

End of Solution

35. Consider the following components:
1. Knowledge of psychology
 2. Knowledge of the theory of variation
 3. Knowledge of process
 4. Knowledge of the system and the theory of optimization
- Which of the above components comprise the basis of Deming's Systems of Profound Knowledge?
- (a) 1, 2 and 3 only (b) 1, 3 and 4 only
(c) 1, 2 and 4 only (d) 2, 3 and 4 only

Ans. (c)

End of Solution

36. Consider the following statements:
1. Greenfield Privatization or Incremental Privatization denotes encouragement to private sector in areas hitherto reserved for Public Enterprises.
 2. Cold Privatization refers to measures taken to distance Public Enterprises from the Government.

Which of the above statements is/are correct?

- (a) 1 only (b) 2 only
(c) Both 1 and 2 (d) Neither 1 nor 2

Ans. (c)

End of Solution

37. Which of the following steps are involved in the product improvement cycle?

1. Sell it in the market
2. Determine quality of performance
3. Design the product based on customer needs
4. Test it in the laboratory

Select the correct answer using the codes given below:

- (a) 1 and 3 only (b) 2 and 4 only
(c) 1, 3 and 4 only (d) 1, 2, 3 and 4

Ans. (d)

The product is injected/sold into the market and performance is evaluated based on feedback about product quality. Improvement in design is carried out based on customer needs and finally tested before infusion into the market.

Source: MADE EASY Class Notes

End of Solution

38. Who is responsible for establishing, documenting and maintaining procedures for post-production handling functions such as storage, packaging and delivery?

- (a) Production Manager (b) Marketing Manager
(c) Vendor (d) Quality Supervisor

Ans. (c)

End of Solution

39. A unit produces packing boxes. Out of hourly production of 4,000 boxes, 20 were found to be non-conforming. If the inspector randomly chooses a box from an hour's production, the probability of it being non-conforming is

- (a) 0.02 (b) 0.10
(c) 0.005 (d) 0.05

Ans. (c)

Hourly production = 4000 boxes
Non-conforming = 20 boxes

$$\text{Probability of being non-conforming} = \frac{20}{4000} = 0.005$$

Source: MADE EASY Class Notes

End of Solution

40. Which of the following are relevant factors regarding quality in service sector?

1. Timeliness of service
2. Customer participation
3. Company personnel motivation
4. Company culture

Select the correct answer using the codes given below:

- (a) 1, 3 and 4 only (b) 1, 2 and 3 only
(c) 1, 2, 3 and 4 (d) 2, 3 and 4 only

Ans. (c)

Source: MADE EASY Class Notes

End of Solution

41. Which one of the following tests can be resorted to in order to check the structural soundness conformance to the specified standards, when all other tests fail?

- (a) Destructive (b) Non-destructive
(c) Full scale load (d) Masonry

Ans. (b)

End of Solution

42. Which of the following are the sources of variation in quality control process in construction?

1. Material
2. Operator
3. Inspection activity

Select the correct answer using the codes given below:

- (a) 1, 2 and 3 (b) 1 and 2 only
(c) 1 and 3 only (d) 2 and 3 only

Ans. (a)

Source: MADE EASY Class Notes and Theory Book (Standard and Quality) Pg. No. 93-94

End of Solution

43. What is the break-even sale for the following products?

	Products		
	A	B	C
Sales (units)	5,000	6,000	4,000
Unit selling price (Rs.)	10	15	18
Unit variable price (Rs.)	6	4	13
Fixed cost of the product is (Rs. 20,000)			

- (a) Rs. 90,000 (b) Rs. 80,000
(c) Rs. 60,000 (d) Rs. 40,000



MADE EASY

India's Best Institute for IES, GATE & PSUs

RPSC Mains Batches

RAJASTHAN PUBLIC SERVICE COMMISSION

Assistant Engineer Examination, 2018
at Jaipur Centre

Batches Commencing from **17th Jan, 2019**

Exam Structure

G.S. + Hindi

- Paper-I
Hindi (100 Marks - 3 Hours)
- Paper-II
Social aspect of Engineering (100 Marks - 3 Hours)

Technical Syllabus

- Civil Engineering
Paper-I (200 Marks - 3 Hours)
- Civil Engineering
Paper-II (200 Marks - 3 Hours)

FEE STRUCTURE

SUBJECTS	TOTAL HOURS	NON-MADE EASY STUDENTS	EX-MADE EASY STUDENTS
G.S. + Hindi	225-250 Hours	₹19,500	₹15,500
Tech + G.S. + Hindi	700-750 Hours	₹52,500	₹43,500

Admission Open

MADE EASY JAIPUR : AB - 559, Kings Road, Nirman Nagar
Ph : 0141-4024612, 09166811228 | www.madeeasy.in

Ans. (d)

$$\begin{aligned} \text{Total sales} &= (5000 \times 10) + (6000 \times 15) + (4000 \times 18) \\ &= 50,000 + 90,000 + 72,000 \\ &= 2,12,000 \end{aligned}$$

$$\begin{aligned} \text{Total variable cost} &= (5000 \times 6) + (6000 \times 4) + (4000 \times 13) \\ &= 30,000 + 24,000 + 52,000 \\ &= 1,06,000 \end{aligned}$$

$$\begin{aligned} \text{Contribution overall} &= 2,12,000 - 1,06,000 \\ &= 1,06,000 \end{aligned}$$

$$\text{Contribution is } \frac{1,06,000}{2,12,000} = 50\% \text{ of sales}$$

Assume new sales to be x

For breakeven

$$0.5x - FC = 0$$

$$x = \frac{FC}{0.5} = \frac{20,000}{0.5} = 40,000$$

End of Solution

44. Which of the following approaches are correct regarding total quality?

1. Opportunity to improve
2. Adoption requires little change
3. React to competitive threats

Select the correct answer using the codes given below:

- | | |
|------------------|------------------|
| (a) 1 and 2 only | (b) 1 and 3 only |
| (c) 2 and 3 only | (d) 1, 2 and 3 |

Ans. (d)

Source: MADE EASY Class Notes and Theory Book (Standard and Quality) Pg. No. 51-52

End of Solution

45. Which of the following are constraints to the use of TQM in construction process?

1. A transient labour force.
2. The construction process is relatively short in duration.
3. Hierarchical and vertical organization structure.
4. The construction process has not focused on the detailed needs of the customer.

Select the correct answer using the codes given below:

- | | |
|------------------|------------------|
| (a) 1 and 4 only | (b) 2 and 3 only |
| (c) 1 and 2 only | (d) 3 and 4 only |

Ans. (c)

Source: MADE EASY Class Notes (Partially)

End of Solution

46. BOD of a waste water sample is estimated to be 180mg/l. Assuming 4 mg/l BOD can be consumed in the BOD bottle, the volume of undiluted sample to be added to a 300 m^l bottle is nearly
- (a) 6.7 m^l (b) 5.6 m^l
(c) 4.4 m^l (d) 3.3 m^l

Ans. (a)

End of Solution

47. Venturi scrubber, a device used to remove particulate matter from the atmosphere, works on the principle of
- (a) Settling by gravitational force
(b) Removal by centrifugal force
(c) Removal by electrically charged particles
(d) Removal by atomized water vapour

Ans. (d)

Venturi scrubber can remove particulate matter as well as larger particles. This type of technology is a part of the group of air pollution control devices collectively referred as 'wet scrubbers'. It is designed to effectively use the energy from the inlet gas stream to atomize the liquid being used to scrub the gas stream.

Note: The term 'scrubber' is used for those pollution control devices that use liquid to wash unwanted pollutants from a gas stream.

End of Solution

48. Environmental Impact Assessment (EIA) is aimed to help
- (a) Estimate future needs of the society
(b) Smooth implementation of a project
(c) Cope with rapid increase in population
(d) Resource conservation

Ans. (d)

Environmental impact assessment (EIA) study is required for the new projects regarding future impacts on the environmental components. It aims to achieve sustainable development taking into care the resource conservation.

Source: MADE EASY Theory Book (Basics of Energy & Environment) {Pg. No. 188}

End of Solution

49. Which one of the following is a terrestrial type of ecosystem?
- (a) Limnetic (b) Estuary
(c) Prairie (d) Reefs

Ans. (c)

Ecosystem is broadly terrestrial and aquatic. Aquatic includes pond, river, lake, wetlands, ocean (Coral reef, limnetic). While terrestrial ecosystems are forest, grassland (Temperate grassland-Prairies/Steppes).

Source: MADE EASY Theory Book (Basics of Energy & Environment) {Pg. No. 57}

End of Solution

50. What are the limitations of solar energy?
1. Collecting solar energy over large areas and converting it to other forms that can be conveniently transported, stored and used in existing equipment is not economical.
 2. Low density of solar energy as compared to coal, oil and gas.
 3. Its major applications are photothermal conversion, solar water heating, green housing technology and photo voltaic conversion.
- Select the correct answer using the codes given below:
- (a) 1, 2 and 3 (b) 1 and 2 only
(c) 1 and 3 only (d) 2 and 3 only

Ans. (b)
Third statement is advantage regarding solar energy rather than limitation. Therefore third statement is wrong and 1 and 2 are correct.

Source: MADE EASY Theory Book (Basics of Energy & Environment) {Pg. No. 6}

End of Solution

51. Acid rain results when gaseous emissions of Sulfur oxides (SO_x) and nitrogen oxides (NO_x) interact with water vapour and
- (a) Moonlight, and are chemically converted to strong acidic compounds such as sulfuric acid (H_2SO_4) and nitric acid (HNO_3)
 - (b) Sunlight, and are chemically converted to strong acidic compounds such as sulfuric acid (H_2SO_4) and nitric acid (HNO_3)
 - (c) Moonlight, and are chemically converted to weak acidic compounds such as sulfuric acid (H_2SO_4) and nitric acid (HNO_3)
 - (d) Sunlight, and are chemically converted to weak acidic compounds such as sulfuric acid (H_2SO_4) and nitric acid (HNO_3)

Ans. (b)
Acid rain has constituents of strong acid (H_2SO_4 and HNO_3).

Source: MADE EASY Theory Book (Basics of Energy & Environment) {Pg. No. 131}

End of Solution

52. The 'Minamata Tragedy' was caused by the eating of fish growing in the Minamata Bay contaminated with
- (a) Peroxy alylnitrate (b) Methyl isocyanate
 - (c) Potassium cyanide (d) Methylmercury

Ans. (d)
Minamata disease is caused by mercury presence (especially water pollution).

Source: MADE EASY Theory Book (Basics of Energy & Environment) {Pg. No. 147}

End of Solution

53. What are the advantages of Biomass as a source of energy?
1. Its storage and transportation is possible
 2. It is ecologically safe and is inoffensive
 3. Can be developed with present man and material abilities
 4. Low capital input required
- Select the correct answer using the codes given below:
- (a) 1, 2, 3 and 4 (b) 1, 2 and 3 only
(c) 1, 3 and 4 only (d) 2, 3 and 4 only

Ans. (a)

Source: MADE EASY Theory Book (Basics of Energy & Environment) {Pg. No. 20}

End of Solution

54. Consider the following data for a domestic biogas plant:
- Number of cows = 5
Retention time = 20 days
Temperature = 30°C
Dry matter consumed = 2 kg/day
Biogas yield = 0.24 m³/kg
Efficiency of burner = 60%
Methane proportion = 0.8
Heat of combustion of Methane = 28 MJ/m³
Density of dry material in fluid = 50 kg/m³
The power available from the digester will be nearly
- (a) 16.2 MJ/day (b) 24.3 MJ/day
(c) 32.3 MJ/day (d) 48.6 MJ/day

Ans. (c)

$$\begin{aligned}\text{Number of cows} &= 5 \\ \text{Total dry matter consumed} &= 5 \times 2 = 10 \text{ kg/d} \\ \text{Total biogas yield} &= 10 \times 0.24 = 2.4 \text{ m}^3/\text{d} \\ \text{Methane produced} &= 2.4 \times 0.6 \times 0.8 = 1.152 \text{ m}^3/\text{d} \\ \text{Total power available from digester} &= 1.152 \times 28 = 32.256 \text{ MJ/day}\end{aligned}$$

End of Solution

55. The best tool to ensure that there is neither piling up of stocks nor shortage of materials in a project to run it economically is
- (a) Economic Order Quantity
 - (b) ABC Analysis
 - (c) Inventory Control and Management
 - (d) Gantt Chart Method

Ans. (c)

End of Solution



56. A machine is expected to generate cash saving (after-tax) of Rs. 50,000 per annum over a period of 5 years. Salvage value of machine is 40% of the original cost. If accounting rate of return is 20%, cost of two such machines will be
- (a) Rs. 78,125 (b) Rs. 1,56,250
(c) Rs. 3,12,500 (d) Rs. 6,25,000

Ans. (c)

$$\text{Depreciation per annum} = \left(\frac{x - 0.4x}{5} \right)$$

x is assumed as initial cost of the machine

$$\text{ARR} = \left[\frac{50,000 - \frac{0.6x}{5}}{x} \right] = 0.2$$

$$50,000 - \frac{6x}{50} = 0.2x$$

$$50,000 = 0.2x + \frac{6x}{50}$$

$$= \frac{10x + 6x}{50}$$

$$16x = 50 \times 50,000$$

$$16x = 25,00,000$$

$$x = \frac{25,00,000}{16}$$

$$x = 1,56,250$$

$$\therefore 2x = 3,12,500$$

End of Solution

57. It is expected to receive Rs. 5,000 annually for 3 years with each receipt occurring at the end of the year. With a discount rate of 10%, the present value of the annuity will be nearly
- (a) Rs. 12,435 (b) Rs. 9,945
(c) Rs. 4,975 (d) Rs. 2,487

Ans. (a)

$$\text{TPV} = \sum \frac{A}{(1+i)^n}$$

$$= \frac{5000}{(1.1)} + \frac{5000}{(1.1)^2} + \frac{5000}{(1.1)^3}$$

$$= 4545 + 4132 + 3757$$

$$= 12435$$

End of Solution

58. In a project life cycle, the maximum percentage of effort is done in
- (a) Concept phase (b) Definition phase
(c) Planning and organizing phase (d) Implementation phase

Ans. (d)

Intensity of activities (% of work done) is highest in implementation phase of PLC.

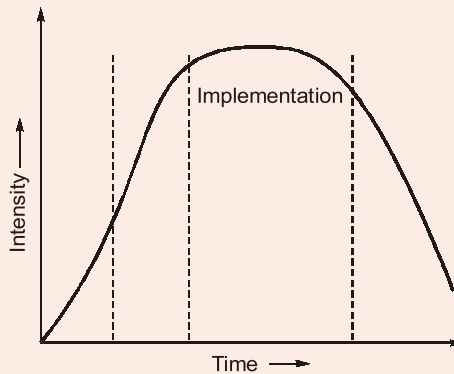

End of Solution

59. In progress of a project, the percentage of error will be less in
- (a) Definitive cost estimate (b) Detailed estimate
(c) Preliminary estimate (d) Study estimate

Ans. (a)

As the project progresses the error in cost estimation of the project decreases sharply from the rough order of magnitude estimates to definitive cost estimate.

End of Solution

60. In principle, the network should not be made complex. No control system, for that matter, can operate unless it is kept simple. This principle is called
- (a) CPM (b) PERT
(c) KISS (d) GERT

Ans. (c)

KISS principle states that most system work best if they are kept simple rather than complicated. Therefore simplicity should be key goal in project management and complexity should be avoided.

End of Solution

61. Which one of the following is a viable alternative to term-loans and are instruments for raising debt finance by large publicly traded firms?
- (a) Shares (b) Debentures
(c) Asset loans (d) Gold loans

Ans. (b)

Debentures are debt instruments which are used by firms/companies to raise money for financing project. Debenture acts as an alternative to term loans.

End of Solution

62. Which one of the following makes the design, assembly and operation of complex systems feasible and practical?
- (a) System Architecture (b) Modularization
(c) Standardization (d) Composition

Ans. (b)

Modularisation is a design approach that subdivides a system into smaller parts called modules that can be independently created and then used in different systems. A modular system can be characterised by functional partitioning into discrete scalable, reusable modules; rigorous use of well defined modular interfaces; and making use of industry standards for interfaces.

Source: MADE EASY Theory Book
(General Principles of Design, Drawing and Importance of Safety)
Pg. 36 (Article 5.2)

End of Solution

63. Which one of the following schedules shows the specific activities necessary to complete an activity or work package?
- (a) Project schedule (b) Master schedule
(c) Task schedule (d) Internal schedule

Ans. (c)

When the project activities have been defined, they are broken down into tasks and after time & resource allocation, task schedules are prepared which is specified activities necessary to complete a work package.

End of Solution

64. In a stable ceramic crystal structure, a cation is surrounded by three anions in the form of a planar equilateral triangle. The ratio of the cation-anion radius for the crystal is nearly
- (a) 0.16 (b) 0.24
(c) 0.32 (d) 0.41

Ans. (a)

For stable crystal structure all the anions which are surrounding a cation should be in direct contact with that cation. This cation-anion contact is established for a specific value of r_C/r_A which is determined from geometrical considerations and assuming hard spherical ions as shown below:

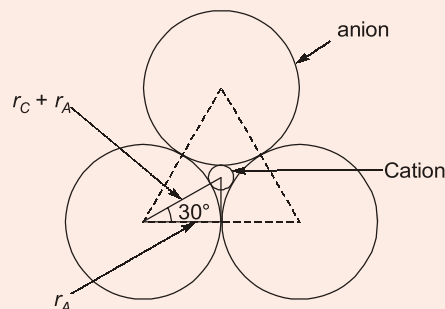



MADE EASY
India's Best Institute for IES, GATE & PSUs*

- ✓ Quality Teaching
- ✓ Comprehensive Study Material
- ✓ Well Planned Curriculum
- ✓ Professionally Managed

Announcing
NEW BATCHES
for **ESE 2020 & GATE 2020**
1 Yr/2Yrs CLASSROOM COURSES

... Early start ... Extra edge

- Suitable for college going, working professionals and passed out aspirants.
- For **Evening (Regular) Batches** classes will be held 6-7 days in a week for 3-4 hrs/day.
* Classes may be extended on weekends & public holidays.
- For **Morning (Regular) Batches** classes will be held 6-7 days in a week for 6 hrs/day.
- For **Weekend Batches** classes will be conducted on weekends and public holidays.
* Classes may be conducted on weekdays during semester breaks.

Batches Commencement Dates

	Delhi	Noida	Rest of India (Regular Batches)		
Weekend Batches	CE	12-Jan-2019	12-Jan-2019	Patna	25 th Feb'19
	ME	12-Jan-2019	12-Jan-2019	Lucknow	20 th Feb'19
	EE	13-Jan-2019	13-Jan-2019	Bhopal	14 th Jan'19
	EC	13-Jan-2019	13-Jan-2019	Indore	20 th Feb'19
	CS	19-Jan-2019		Pune	14 th Jan'19
Regular Batches	CE	15-Jan-2019, 14-Feb-2019		Hyderabad	17 th Feb'19
	ME	15-Jan-2019, 14-Feb-2019		Bhubaneswar	24 th Jan'19
	EE	17-Jan-2019, 18-Feb-2019		Kolkata	15 th Jan'19
	EC	17-Jan-2019		Jaipur	17 th Feb'19
	CS	16-May-2019			

Admission open

Corporate office : 44-A/1, Kalu Sarai, New Delhi - 1100 16 ☎ 011-45124612, 9958995830

Centres | Delhi | Hyderabad | Noida | Jaipur | Bhopal | Lucknow | Indore | Bhubaneswar | Pune | Kolkata | Patna
011-45124612 | 040-66774612 | 0120-6524612 | 0141-4024612 | 0755-4004612 | 09919111168 | 0731-4029612 | 09040299888 | 020-26058612 | 8981888880 | 0612-2356615

$$\cos 30^\circ = \frac{r_A}{r_C + r_A}$$

$$\Rightarrow \frac{r_C}{r_A} = 0.155 \simeq 0.16$$

Source: MADE EASY Class Notes (GS Batch)

Chapter: Ceramics, Heading: Ceramic Crystal Structure (Second Criteria)

End of Solution

65. During tensile testing of a material, if cross-sectional area of the specimen is doubled, the load required to produce the same elongation shall be
- (a) Double (b) Half
(c) Same (d) Four times

Ans. (a)

Elongation (δ) of a bar under tensile load is given by,

$$\delta = \frac{PL}{AE}$$

For same elongation (δ)

$$\delta_1 = \delta_2$$

$$\frac{P_1 L_1}{A_1 E_1} = \frac{P_2 L_2}{A_2 E_2}$$

$$\frac{P_2}{P_1} = \left(\frac{A_2}{A_1}\right)\left(\frac{E_2}{E_1}\right)\left(\frac{L_1}{L_2}\right)$$

$$\frac{P_2}{P_1} = \left(\frac{2A}{A}\right)\left(\frac{E}{E}\right)\left(\frac{L}{L}\right)$$

$$P_2 = 2P_1$$

Source: MADE EASY Class Notes (GS Batch)

Chapter: Mechanical Properties of Materials (Heading: Tension Test)

End of Solution

66. When two or more chemically different monomers are polymerized to form a cross link polymer along with some byproduct such as water, the process is known as
- (a) Crystallographic polymerization (b) Addition polymerization
(c) Copolymerization (d) Condensation polymerization

Ans. (d)

When two or more chemically different monomers are polymerized to form a cross-link polymer along with some by product such as water, the process is known as condensation polymerisation.

1. Source: MADE EASY Class Notes (GS Batch)

Chapter: Polymer, Heading: Condensation Polymerisation

**2. Source: MADE EASY Workbook GS (Basics of Material Science)
(Q.138; Page-127)**

End of Solution

- 67.** The number of atoms per unit length whose centres lie on the direction vector for a specific crystallographic direction is called
- (a) Linear density (b) Theoretical density
(c) Atomic density (d) Avogadro number

Ans. (a)

Linear density: It is defined as number of atoms per unit length whose centres lie on the direction vector for a specific crystallographic direction.

$$\text{Linear density} = \frac{\text{Number of atoms centred on direction vector}}{\text{Length of direction vector}}$$

End of Solution

- 68.** Which of the following features of atoms determine the degree to which the solute atoms dissolve in the solvent atoms?
1. Atomic size factor
2. Crystal structure
3. Electronegativity
- (a) 1 and 2 only (b) 1 and 3 only
(c) 2 and 3 only (d) 1, 2 and 3

Ans. (d)

Following are the factors which determine the limits of solubility. These are expressed as a series of rules called **William Hume-Rothery** rules. These are

1. Atomic size factor rule
2. Crystal structure rule
3. Valency rule
4. The electronegativity rule

End of Solution

- 69.** A state for ionic compounds wherein there is the exact ratio of cations to anions as predicted by the chemical formula is
- (a) Electroneutrality (b) Stoichiometry
(c) Equiliometry (d) Frankel defect



Ans. (b)

Stoichiometry may be defined as a state for any compounds where in there is the exact ratio of cations to anions as predicted by the chemical formula.

End of Solution

70. The capacity of a material to absorb energy when it is deformed elastically and then, upon unloading, to have this energy recovered is called
- (a) Ductility (b) Tensile strength
(c) Elasticity (d) Resilience

Ans. (d)

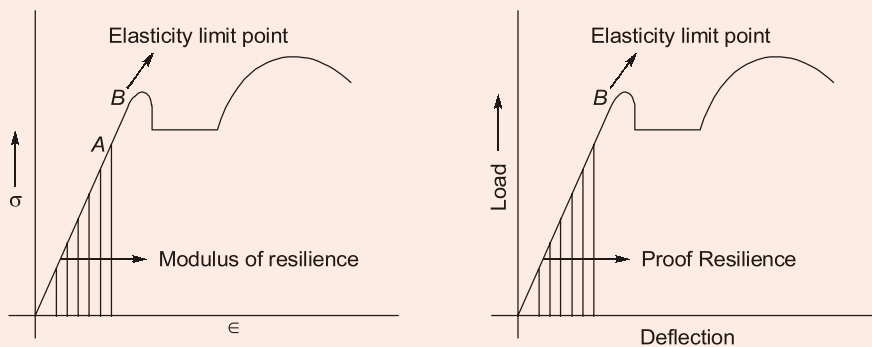

Resilience is the capacity of a material to absorb energy when it is deformed elastically and then, upon unloading to have this energy recovered.

Source: MADE EASY Class Notes (GS Batch)

Chapter: Mechanical Properties of Materials (Heading: Resilience)

End of Solution

71. In which one of the following phase transformations, there are no compositional alterations?
- (a) Incongruent transformations
(b) Congruent transformations
(c) Non-equilibrium transformations
(d) Equilibrium transformations

Ans. (b)

- Phase transformations for which there are no compositional alterations are called congruent transformations.

Ex.: allotropic transformations (e.g. α -Fe to γ -Fe) and melting of pure metals.

- Those transformations for which at least one of the phases will experience a change in composition are called incongruent transformations.

Ex.: eutectic and eutectoid reactions and melting of an alloy that belongs to an isomorphous system.

End of Solution

72. In a simple cubic structure, atomic power factor is nearly
(a) 0.9 (b) 0.7
(c) 0.5 (d) 0.3

Ans. (c)

$$\text{Atomic packing factor} = \frac{\text{Sum of atomic volume in a unit cell}}{\text{Volume of a unit cell}}$$

$$\Rightarrow \text{APF} = \frac{N \times \frac{4}{3} \pi r^3}{a^3}$$

For simple cubic

$$N = \frac{1}{8} \times 8 = 1 \text{ atom/unit cell}$$

$$r = \frac{a}{2}$$

$$\therefore \text{APF} = \frac{1 \times \frac{4}{3} \pi \left(\frac{a}{2}\right)^3}{a^3} = 0.52$$

Source: MADE EASY Class Notes (GS Batch)

Chapter : Crystallography, Heading: Simple Cubic Crystal Structure

End of Solution

73. Which of the following are the advantages of coding audiovisual objects?
1. It allows interaction with the content
 2. It improves reusability and coding the content
 3. It allows content-based scalability
- (a) 1 and 2 only (b) 1 and 3 only
(c) 2 and 3 only (d) 1, 2 and 3

Ans. (d)

Coding audio-video information for example music, videos, movies, etc (for example there is Moving Pictures Expert Group - MPEG) has led to multiple benefits. As every object has binary mask thus more interaction, modification and re-use is possible. There is also use of compression standards which obviously leads to better scalability of the content. It has also led to the growth of interactive web-based creative multi-media content and Digital TV. Coded multimedia audio-video digital content can be better synchronized and integrated.

End of Solution

74. The transmission of real-time streams across networks uses Bandwidth Allocation Mechanism (BAM), which is based on
- (a) Stream peak rate (b) Bucket rate
(c) Token bucket depth (d) Packet size

Ans. (a)

Bandwidth Allocation Mechanism (BAM) is based on the Stream Peak Rate, and it is used inside Premium Service Architecture in order to support real-time stored stream transmission. Thus, it helps in checking the need for additional bandwidth allocation in multi-media transmission in any communication channel.

End of Solution

75. The quality of service provided in a computer network is
- (a) Presentation layer issue (b) Session layer issue
(c) Network layer issue (d) Data link layer issue

Ans. (c)

Network Layer is layer of internet just above Data Link Layer and below Transport Layer in 7-Layered Open System Interconnection (OSI) Model. In a computer network issues like delay, transit time, jitter, routing, etc affect the quality of network services and these are in normal course part of Network Issue. Network Layer includes routing services, IP addressing, internet traffic control, etc. Though Application Layer – the top-most layer serves as the main layer for application services or Application Programming Interface (API).

End of Solution

76. The Pre-echo PE distortions in audio signal represents the
- (a) Theoretical limit on compressibility of particular signals
(b) Imaginary components of a signal
(c) Critical band analysis of a signal
(d) Histogram of the signals

Ans. (a)

Pre-echo, also referred to as forward echo, can occur when transient sound can cause a type of distortion, and it denotes theoretical limit on compressibility of a particular signal. Pre-echo occurs when signals with sharp attack begin near the end of transform block immediately following a region of low energy.

End of Solution

77. In a computer network, a point-to-point transmission, with one sender and one receiver is called
- (a) Unicasting (b) Multicasting
(c) Broadcasting (d) Internetworking

Ans. (a)

A transmission between a single transmitter and a single receiver is a unicast transmission, thus in it packets are sent to a single network destination in a particular address (one-to-one). Debra Cameron, '*Internet2*' – *The Future of the Internet and Next-generation Initiatives* "Unicast transmission is sent point to point from one sender to one receiver".

While, multicast transmission denotes transmission of information between one or several transmitters and several receivers (one-to-many). Whereas in broadcast it is one-to-all that is to all possible destinations.

End of Solution

78. The Protocol (http), the DNS name of the host, and the file name is identified through
- (a) Uniform Resource Locator
 - (b) Web Browser
 - (c) Web Server
 - (d) IP address

Ans. (a)

Domain name of a website is hosted on some IP Address, while Uniform Resource Locator (URL) is the unique web address of a web page. Thus, multiple web pages in a website have unique web addresses in that domain name. Hyper Text Transfer Protocol (HTTP) or its more secure version Hyper Text Transfer Protocol Secure (HTTPS) is used for data transmission in the web traffic. Uniform Resource Locator – main form of Uniform Resource Identifier (URI) – obvious, is made of retrieval method/protocol (HTTP here), the host server and the domain name and that web page address/location.

End of Solution

79. The traditional way to handle forms and other interactive Web pages is a system called
- (a) Graphical User Interface
 - (b) Common Gateway Interface
 - (c) Text Based User Interface
 - (d) Command Line Interface

Ans. (b)

Common Gateway Interface (CGI) has traditionally been used for interactive web pages or communication in then World Wide Web (WWW). Active Servers Pages (ASP) are used for more interactivity of web pages. Common Gateway Interface (CGI) specifications govern the interaction of web servers and external programs.

End of Solution

80. Pretty Good Privacy (PGP) which encrypts the data by using a block cipher is used in
- (a) FTP security
 - (b) e-mail security
 - (c) Browser security
 - (d) Bluetooth security

Ans. (b)

Pretty Good Privacy (PGP) is a program that uses encryption to protect the privacy of e-Mail or even other data files. Now it is more popular email encryption software used for digitally signing emails or other data thus enhancing security features.

End of Solution

81. The core elements of high-level programming languages are
- (a) Keywords, Expressions and Punctuation
 - (b) Functions, Keywords and Operators
 - (c) Keywords, Operators and Punctuation
 - (d) Functions, Expressions and Operators

Ans. (c)

Individual statements that are used in a program in a High-Level Language (HLL) are called statements, and a programming statement nearly in all high-level programming languages (say Application Programming Interfaces or APIs) includes keywords, operators and punctuation. While Machine Level Languages (MLLs) are binary based say Operating System (OS), High Level Languages (HLLs) say multiple Application Programs are based on Alpha-Numerals.

End of Solution

82. The philosophical study of beliefs and knowledge is better known as
- (a) Ontology
 - (b) Epistemology
 - (c) Entomology
 - (d) Etymology

Ans. (b)

The above statement forms the definition of Epistemology.

End of Solution

83. One branch of ethical philosophy-claims that it is possible to know right from wrong or good from bad in a very clear and objective manner, is called
- (a) Non-Cognitivism
 - (b) Ethical Pluralism
 - (c) Cognitivism
 - (d) Utilitarianism

Ans. (c)

The above statement defines Cognitivism.

End of Solution

84. Consider the following statements regarding '*Engineering Ethics*':
1. It is the activity of understanding moral values
 2. It resolves the moral issues and justifies moral judgments
 3. It would refer to the set of specifically moral problems and issues related to Engineering
- Which of the above statements are correct?
- (a) 1, 2 and 3
 - (b) 1 and 2 only
 - (c) 1 and 3 only
 - (d) 2 and 3 only

Ans. (a)

All the chosen statements are in coherence with scope of Engineering Ethics.

Source: MADE EASY Theory Book
(Ethics and Values in Engineering Profession) {Pg. No. 3}

End of Solution

MADE EASY

National Scholarship Test

For ESE 2020 & GATE 2020



Scholarship

worth

₹ **5**
Crores

Scholarship applicable on batches commencing between April 2019 to July 2019.

Talent and aspiration is always an invincible combination. But if these two are facing disability to prosper due to unfavourable economic conditions then achieving academic goals is like chasing rainbows.

If you are one amongst such talented aspirants who dream about Engineering Services, PSUs and IITs but economic condition is a hurdle in the way of your dreams. MADE EASY is taking an initiative to turn this stumbling block to building block by giving scholarship for coaching guidance and thereby assisting all such students in accomplishing their dreams.

MADE EASY is announcing scholarship worth Rs. 5 Crores for all students who wish to enroll in classroom programmes for ESE -2020 and GATE-2020.

Category	Scholarship % in Tuition fee
A	100%
B	75%
C	50%
D	25%
E	10%

Test Pattern & Syllabus

National Scholarship Test is objective type offline test.

Students can opt either TECHNICAL BASED PAPER or APTITUDE BASED PAPER to appear for NST.

Total Marks : 100 | Total Questions : 50 Q | Time Duration : 1 hour | Per Question : 2 marks | Negative Marking : 0.66 marks

Option 1 TECHNICAL BASED PAPER : SYLLABUS

CIVIL	MECHANICAL	ELECTRICAL	ELECTRONICS	COMPUTER SCIENCE
SOM : 8Q	Thermodynamics : 6Q	Networks : 8Q	Networks : 8Q	TOC : 8Q
RCC : 8Q	HMT : 6Q	Control Systems : 8Q	Control Systems : 8Q	Algorithm : 8Q
Soil Mechanics : 8Q	FM : 6Q	Electrical Machines : 8Q	EDC : 6Q	Operating Systems : 8Q
Environmental : 8Q	Production : 10Q	Power Systems : 8Q	Analog Electronics : 8Q	DBMS : 8Q
FM : 8Q	Industrial : 6Q	Measurements : 6Q	Digital Electronics : 6Q	Computer Networks : 6Q
Highway : 5Q	SOM : 8Q	Analog Electronics : 6Q	Communications : 8Q	Digital Electronics : 6Q
Survey : 5Q	TOM : 8Q	Digital Electronics : 6Q	Signal & Systems : 6Q	Compiler Designs : 6Q

Option 2 APTITUDE BASED PAPER : SYLLABUS

Engineering Mathematics : 20 Q

Reasoning & Aptitude : 20 Q

General English : 10 Q



Date of Test : 10th Mar, 2019

Last date to register : 25th Feb, 2019

Register online at :
www.madeeasy.in

Helpline :
☎ 011-45124612 | ✉ nst@madeeasy.in

85. A situation where very high prices are charged from customers for a limited period of time is known as
- (a) Gouging (b) Zipping
(c) Bamboozing (d) Hoodwinking

Ans. (a)
The above statement forms the definition of Gouging.

End of Solution

86. Consider the following steps for an individual regarding preparation for disclosure of unethical behaviour:
1. Study and document the facts and formulate a plan for an appeal.
 2. Take up the matter with higher management.
 3. Discuss the matter with immediate supervisor.
 4. If the internal appeal does not resolve the conflict, then he should notify the company that he intends to continue with an external review of the problem.
- What is the correct sequence of order of the above steps?
- (a) 2, 3, 1 and 4 (b) 1, 3, 2 and 4
(c) 3, 2, 4 and 1 (d) 1, 2, 3 and 4

Ans. (b)
The order of the statement chosen form the logical sequence with respect to an individual regarding preparation for disclosure of unethical behaviour.

End of Solution

87. Which of the following are the attributes of a profession?
1. The work requires sophisticated skills, use of judgment and exercise of discretion
 2. Membership in the profession does not require extensive formal education as well as practical training
 3. There are set standards for admission to the profession and conduct for members
 4. Significant public good results from practice of the profession
- Select the correct answer using the codes given below:
- (a) 1, 2 and 3 only (b) 1, 2 and 4 only
(c) 1, 3 and 4 only (d) 2, 3 and 4 only

Ans. (c)
The chosen statements are in line with the definition of profession.

Source: MADE EASY Theory Book
(Ethics and Values in Engineering Profession) {Pg. No. 121}

End of Solution

88. What are the core qualities of a professional practitioner?
1. Integrity both with themselves and with others
 2. Independence-to be free of secondary interests with other parties
 3. Competence
 4. Discretion-care with communications

Select the correct answer using the codes given below:

- (a) 1, 2, 3 and 4 (b) 1, 2 and 3 only
(c) 1 and 3 only (d) 3 and 4 only

Ans. (a)

The chosen statements form the core qualities of a professional practitioner.

**Source: MADE EASY Theory Book
(Ethics and Values in Engineering Profession) {Pg. No. 120}**

End of Solution

Q.89 When should whistle blowing be attempted?

1. There must be a clear and great harm that can be avoided
2. The whistleblower must be in a clear position to report on the problem
3. The whistleblower must have a reasonable chance of success in stopping the harmful activity
4. The whistleblower feels that all other lines of action within the context of the organization have been explored and shut off

Select the correct answer using the codes given below:

- (a) 1, 2, 3 and 4 (b) 1, 2 and 4 only
(c) 1, 3 and 4 only (d) 2 and 3 only

Ans. (b)

The chosen statements, while disregarding statement 3, are rational in tandem with attempting to whistleblowing.

**Source: MADE EASY Theory Book
(Ethics and Values in Engineering Profession) {Pg. No. 88}**

End of Solution

90. Which of the following are the salient features of the Patent Act 1970 ?

1. It codifies inventions which are not patentable
2. It provides for endorsement of patent with the words 'license of right'
3. It provides for revocation of patents in public interest
4. It has provision for validity period also for the patents

Select the correct answer using the codes given below:

- (a) 1, 2, 3 and 4 (b) 1, 2 and 4 only
(c) 1, 3 and 4 only (d) 2 and 3 only

Ans. (c)

Statement 2 was dropped vide amendment in the said Patent Act 1970, in 2002.

End of Solution

Directions : Each of the next **Ten (10)** items consists of two statements, one labelled as 'Statement (I)' and the other as 'Statement (II)'. You are to examine these two statements carefully and select the answers to these items using the codes given below:

Codes:

- (a) Both Statement (I) and Statement (II) are individually true; and Statement (II) is the correct explanation of Statement (I)
- (b) Both Statement (I) and Statement (II) are individually true; but Statement (II) is NOT the correct explanation of Statement (I)
- (c) Statement (I) is true; but Statement (II) is false
- (d) Statement (I) is false; but Statement (II) is true

91. **Statement (I) :** All projects have constraints or limitations that inhibit their ability to reach goals and objectives.

Statement (II) : Time and money are universal constraints in projects.

Ans. (b)

Projects are subject to several constraints including time, money, quality, resource and risks. Constraints tend to inhibit project management ability to reach the goals of the project. Besides time and money often vital constraints like quality and risks are constantly working throughout the project life cycle.

Source: MADE EASY Theory Book, Chapter-1, Basics of Project Management

End of Solution

92. **Statement (I) :** Training should be conducted among the line and low management for ensuring the importance of environmental protection plan.

Statement (II) : Environmental science is a developing subject and the people implementing environment strategies should remain up to date with the environmental control processes.

Ans. (a)

Environmental science is new and evolving branch of science. Therefore training is required to have expertise in tackling the environmental issues especially in lower management.

Source: MADE EASY Theory Book/Class Notes

End of Solution

93. **Statement (I) :** Metals having same crystal structure will have greater solubility.

Statement (II) : Differences in crystal structure limits the solid solubility.

Ans. (a)

According to Hume-Rothery rule, for appreciable solid solubility, the crystal structure of two elements must be identical.

End of Solution

94. **Statement (I)** : The tie line is constructed across the two-phase region at the temperature of the alloy.

Statement (II) : The overall alloy composition is located on the tie line.

Ans. (b)

As per lever rule, a tie line is constructed in the two-phase region. The fulcrum of the tie line will be on the overall composition of the alloy. The corner points of the tie line tell us the mass fractions of the two different phases present in the region.

End of Solution

95. **Statement (I)** : Cross linked polymers may be synthesized in which side-branch chains are connected to the main ones.

Statement (II) : Linear polymers are those in which the repeat units are joined together end to end in single chains.

Ans. (b)

- Linear polymers are those in which simple molecules join together end to end in single chains.

Source: 1. MADE EASY Theory Book (Basics of Material Science)

Linear chain structure (Page 118)

2. MADE EASY Class Notes: Discussion during thermoplastic material

- Crosslinked polymer has interlinking chains connecting adjacent linear chains.

Source: 1. MADE EASY Theory Book (Basics of Material Science)

Cross linked structure (Page 119)

2. MADE EASY Class Notes: Discussion in the Beginning for Basic Definitions in Polymers.

Also again during thermosetting plastics.

End of Solution

96. **Statement (I)** : Abrasive ceramics are used to wear, grind, or cut away other material, which necessarily is softer.

Statement (II) : The prime requisite for abrasive ceramic group of materials is hardness or wear resistance and a high degree of toughness is essential to ensure that the abrasive particles do not easily fracture.

Ans. (a)

Abrasive ceramics are used to wear, grind, or cut away other material, which necessarily is softer. Therefore, the prime requisite for this group of materials is hardness or wear resistance; in addition, a high degree of toughness is essential to ensure that the abrasive particles do not easily fracture. Furthermore, high temperatures may be produced from abrasive frictional forces, so some refractoriness is also desirable.

1. Source: MADE EASY Class Notes (GS Batch)

Chapter : Ceramics/Composites

Heading: (1) Properties of Ceramics (2) Cermet (Composites)

2. GS: Basics of Material Science, Workbook similar question

(Q.141; Page 127)

End of Solution



MADE EASY

India's Best Institute for IES, GATE & PSUs

- ✓ Quality Teaching
- ✓ Well Planned Curriculum
- ✓ Professionally Managed
- ✓ Outstanding Results

LAUNCHING

70 DAYS SUMMER GATE COURSE for GATE 2020 **New**

Especially designed for
2nd / 3rd / 4th year college going students

CE | ME/PI | EE | EC/IN | CS

"GATE Classroom Course During College Summer Holidays"

Salient Features

- **70 days intensive course**, 8 to 10 hrs classes per day.
- Total 600-650 teaching hours.
- Lectures will be delivered by experienced faculties.
- This course is also helpful in academic gains i.e. good results in university examinations, placements etc., hence highly beneficial for college going students.
- GATE exam relevant study material will be provided.
- Subjects will be culminated with class tests and doubt clearing sessions.

Admission
open from
1st Nov, 2018

Batches
starting from
19th May, 2019

Hostel/PG facility
will be arranged.

Batches
commencing from

CE
19-May-2019

ME/PI
19-May-2019

EE
19-May-2019

EC/IN
19-May-2019

CS
19-May-2019

For fee structure, batch schedule, online admission and other details, visit : www.madeeasy.in

MADE EASY Corporate Office : 44-A/1, Kalu Sarai (Near Hauz Khas Metro Station) New Delhi-16 • Ph : 011-45124612, 9958995830

97. **Statement (I)** : The prevention costs increase with the introduction of a quality system and may be a significant proportion of the total quality costs.

Statement (II) : Costs associated with education and training are not included in prevention costs.

Ans. (c)

Source: MADE EASY Class Notes and Theory Book (Standard and Quality) {Pg. No. 4-5}

End of Solution

98. **Statement (I)** : An emulator is not a mixture of hardware and software and it cannot be used to test and debug the hardware and software of an external system.

Statement (II) : Part of the hardware of an emulator is a multiwire cable which connects the host system to the system being developed.

Ans. (d)

End of Solution

99. **Statement (I)** : Agency-loyalty is acting to fulfill one's contractual duties to an employer.

Statement (II) : Agency-loyalty is entirely a matter of actions, whatever its motives.

Ans. (b)

End of Solution

100. **Statement (I)** : An EIA is a study of the probable changes in socio-economic and biophysical characteristics of the environment that may result from a proposed action.

Statement (II) : The purposes of an EIA is to help design projects, which do not disturb the quality of the environment by examining alternatives.

Ans. (b)

Source: MADE EASY Theory Book (Basics of Energy & Environment) {Pg. No. 186}

End of Solution

