

CCE RF
CCE RR
REVISED

A

ಕರ್ನಾಟಕ ಪ್ರೌಢ ಶಿಕ್ಷಣ ಪರೀಕ್ಷಾ ಮಂಡಳಿ, ಮಲ್ಲೇಶ್ವರಂ, ಬೆಂಗಳೂರು – 560 003
KARNATAKA SECONDARY EDUCATION EXAMINATION BOARD, MALLESWARAM,
BANGALORE – 560 003

ಎಸ್.ಎಸ್.ಎಲ್.ಸಿ. ಪರೀಕ್ಷೆ, ಮಾರ್ಚ್/ಏಪ್ರಿಲ್ – 2019
S. S. L. C. EXAMINATION, MARCH/APRIL, 2019

ಮಾದರಿ ಉತ್ತರಗಳು
MODEL ANSWERS

ದಿನಾಂಕ : 23. 03. 2019]

ಸಂಕೇತ ಸಂಖ್ಯೆ : **72**

Date : 23. 03. 2019]

CODE NO. : **72**

ವಿಷಯ : ಇಂಜಿನಿಯರಿಂಗ್ ಗ್ರಾಫಿಕ್ಸ್ - 2

Subject : ENGINEERING GRAPHICS - 2

(ಹೊಸ ಪಠ್ಯಕ್ರಮ / New Syllabus)

(ಶಾಲಾ ಅಭ್ಯರ್ಥಿ & ಪುನರಾವರ್ತಿತ ಶಾಲಾ ಅಭ್ಯರ್ಥಿ / Regular Fresh & Regular Repeater)

[ಗರಿಷ್ಠ ಅಂಕಗಳು : 50

[Max. Marks : 50

Qn. Nos.	Sub. Qn.No.	Value Points	Total
1.		A square prism of base side 40 mm and axis 60 mm is resting on its base on the ground. Draw its projections when a face is perpendicular to the V.P. 5	

RF + RR(A)-1006

[Turn over

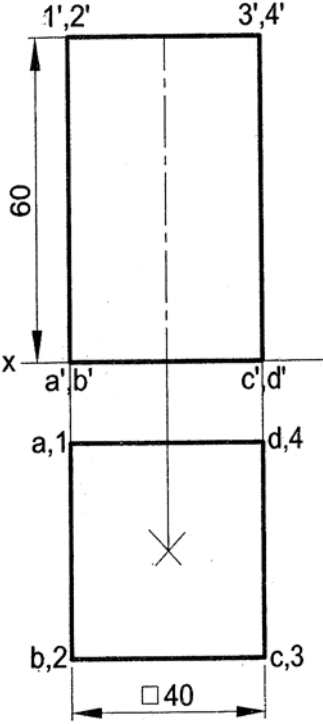
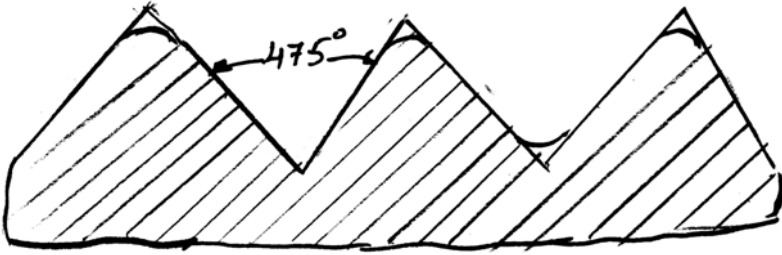
Qn. Nos.	Sub. Qn.No.	Value Points	Total
		<p><i>Ans.</i></p>  <p>Font view - 2½ Top view - 2½</p>	5
2.		<p>With a neat sketch show the proportions and angle of the following threads :</p> <p>a) B. A. thread b) Square thread.</p> <p><i>Ans.</i></p> <p>a)</p>  <p>B. A. Thread</p>	5

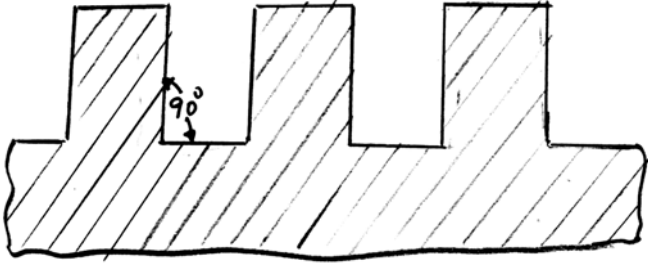
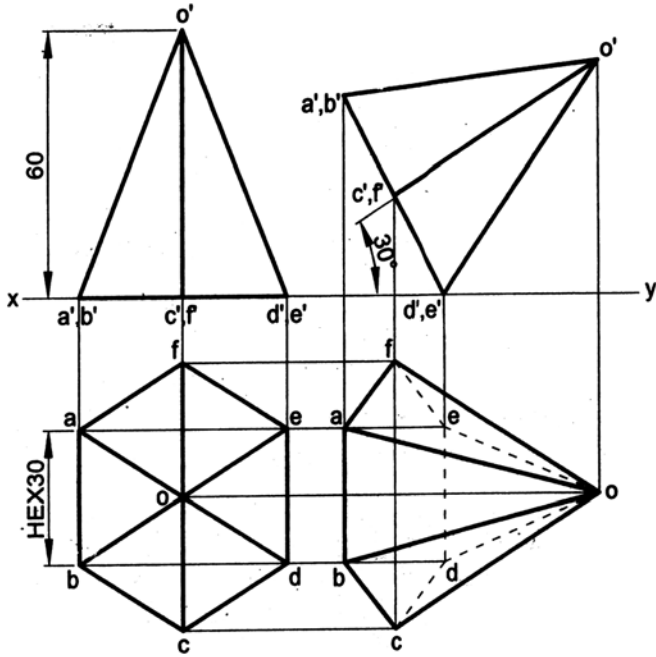
Qn. Nos.	Sub. Qn.No.	Value Points	Total
		<p>b)</p>  <p>Square Thread</p>	2½
3.		<p>A hexagonal pyramid of base side 30 mm and axis 60 mm has an edge of its base on the ground. Its axis is inclined at 30° to the ground and parallel to the V.P. Draw its projections.10 Ans.</p>  <p style="text-align: right;"> First stage = 5 (2½ + 2½) Second stage = 5 (Final projection) = 2½ + 2½ </p>	10
OR			

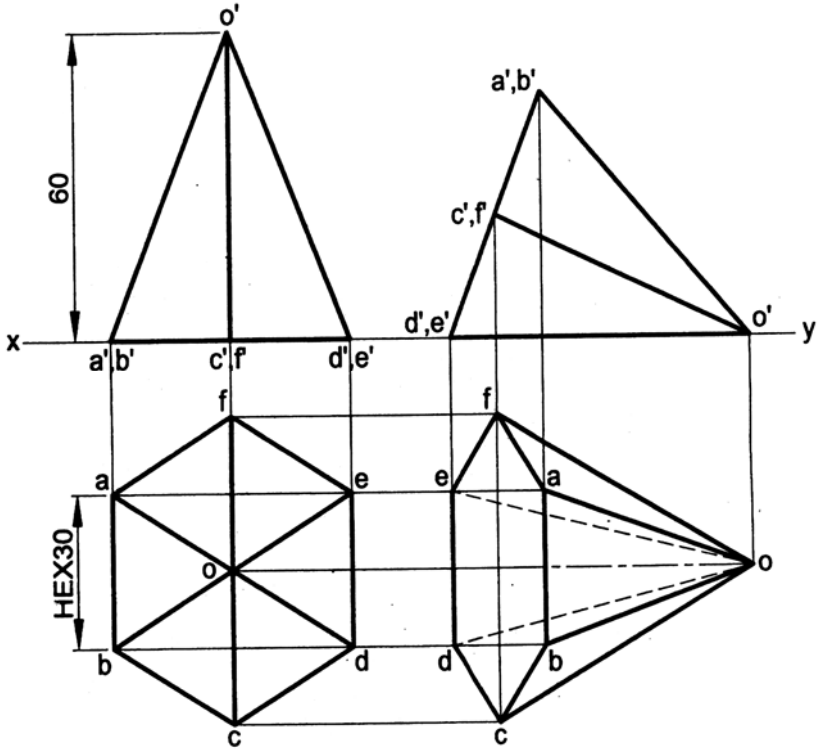
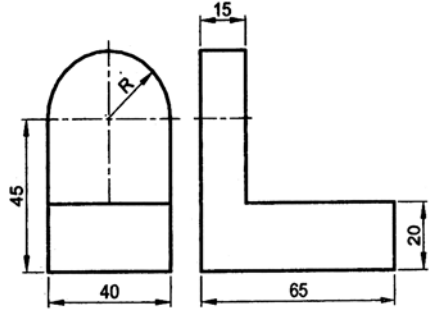
Qn. Nos.	Sub. Qn.No.	Value Points	Total
		<p>A hexagonal pyramid of base edge 30 mm and axis 60 mm has a triangular face on the ground and the axis parallel to the V.P. Draw its projections. 10</p> <p>Ans.</p>  <p style="text-align: right;"> First stage = 5 (2½ + 2½) Second stage = 5 (Final projection) = 2½ + 2½ </p>	10
4.		<p>The front and right hand side views of an angle plate are shown in figure No. 1. Draw its isometric view. 10</p>  <p style="text-align: center;">Figure No. 1</p>	

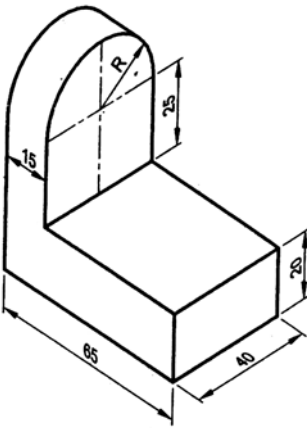
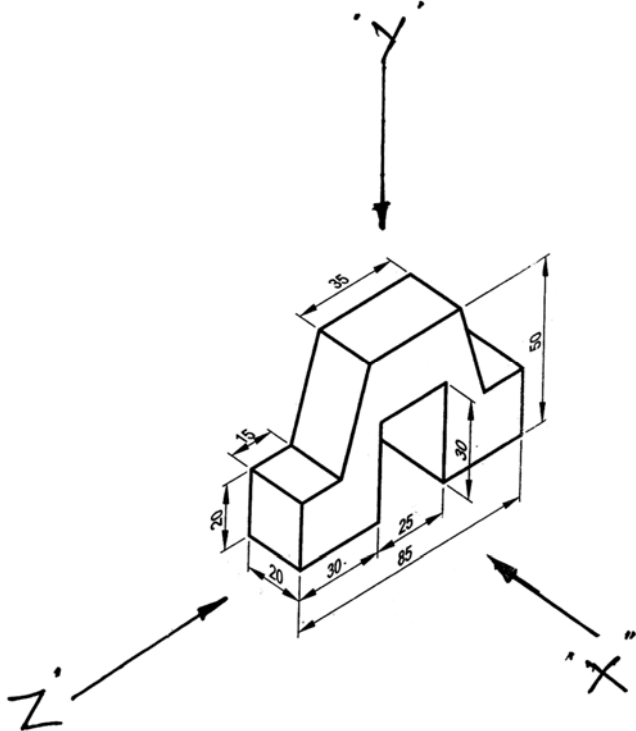
Qn. Nos.	Sub. Qn.No.	Value Points	Total
		<p>Ans.</p>  <p>Drawing of isometric view = 8 Dimensioning = 2</p>	10
5.		<p>The pictorial view of an object is shown in figure No. 2. Draw the following orthographic views and mark the dimensions :</p> <ol style="list-style-type: none"> Front view — looking in the direction of arrow 'X' Top view — looking in the direction of arrow 'Y' Side view — looking in the direction of arrow 'Z'.  <p>Figure No. 2</p>	10

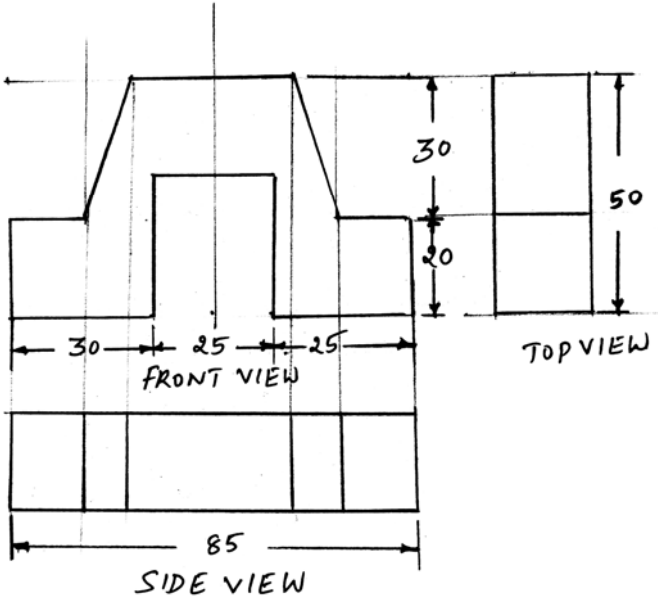
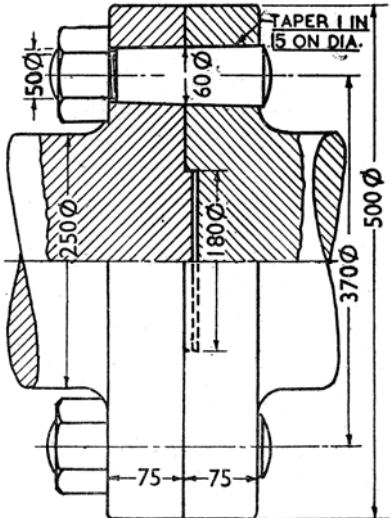
Qn. Nos.	Sub. Qn.No.	Value Points	Total
		<p>Ans.</p>  <p style="text-align: right;"> Front view = 3 Top view = 3 Side view = 3 Dimensioning = 1 </p>	<p>10</p>
<p>6.</p>		<p>Figure No. 3 shows the sectional elevation of a solid flanged coupling. Draw the sectional elevation of a solid flanged coupling to half full size (1 : 2 size) and mark dimensions.</p>  <p style="text-align: center;">SOLID FLANGED COUPLING Figure No. 3</p>	<p>10</p>

Qn. Nos.	Sub. Qn.No.	Value Points	Total
		<i>Ans.</i>	
		i) Draw the sectional elevation of a solid flanged coupling to half full size (1 : 2 size). 8	
		ii) Dimensioning. 2	
			10

