



Regd. Office : Aakash Tower, 8, Pusa Road, New Delhi-110005 | Ph.: 011-47623456

Answers & Solutions

for

NTSE (Stage-I) 2019-20

INSTRUCTIONS TO CANDIDATES

Read the following instructions carefully before you open the question booklet.

1. Use blue/black ballpoint pen only. There is no negative marking.
2. Part I : MAT : 1 - 100 questions
Part II : SAT : 101 - 200 questions
3. This test booklet contains 200 questions of one mark each. All the questions are compulsory.
4. Answer each question by darkening the one correct alternative among the four choices on the OMR SHEET with blue/black ballpoint pen.

Example :

Q. No.	Alternatives
Correct way : 1	① ② ● ④
Q. No.	Alternatives
Wrong way : 1	⊗ ⊖ ⊙ ④

Student must darkening the right oval only after ensuring correct answer on OMR Sheet.

5. Students are not allowed to scratch / alter / change out an answer once marked on OMR Sheet, by using white fluid / eraser / blade / tearing / wearing or in any other form.
6. Separate sheet has been provided for rough work in this test booklet.
7. Please handover the OMR Sheet to the invigilator before leaving the Examination Hall.
8. Darken completely the ovals of your answer on OMR Sheet in the time limit allotted for that particular paper.
9. Your OMR Sheet will be evaluated through electronic scanning process. Incomplete and incorrect entries may render your OMR Sheet invalid.
10. Use of electronic gadgets, calculator, mobile etc, is strictly prohibited.

PART-I : MENTAL ABILITY TEST (MAT)

Direction : (Q.1 to Q.5) : In each question, the numbers are arranged in a sequence based on certain principle. Select the answer from the given four alternatives under each sequence.

1. 2, 6, 15, 31, 56,?.....

- (1) 87 (2) 67
(3) 93 (4) 92

Answer (4)

Sol. 2, 6, 15, 31, 56, 92

4	9	16	25	36
2^2	3^2	4^2	5^2	6^2

2. 5040, 840, 168, 42, 14,?.....

- (1) 2 (2) 1
(3) 7 (4) 4

Answer (3)

Sol. 5040, 840, 168, 42, 14, 7

/	/	/	/	/
6	5	4	3	2

Divide

3. 14, 24, 41, 65, 96,?.....

- (1) 134 (2) 124
(3) 144 (4) 154

Answer (1)

Sol. 14, 24, 41, 65, 96, 134

∨	∨	∨	∨	∨
10	17	24	31	38
∨	∨	∨	∨	∨
7	7	7	7	7

4. 2, 3, 4, 4, 6, 12, 16, 12, 36,?....., 24

- (1) 64 (2) 256
(3) 48 (4) 28

Answer (2)

Sol. 2, 3, 4, 4, 6, 12, 16, 12, 36, 256 34

x2	x2	x2	x2	x2	x2	x2	x2	x2	x2

Each number power '2'
 $2^2 \rightarrow 4^2 \rightarrow 16^2 \rightarrow 256$

5. 5, 1, 11, 6, 17, 36, 23,?.....

- (1) 216 (2) 108
(3) 54 (4) 59

Answer (1)

Sol.

+6	+6	+6	+6	+6	+6	+6	+6
5,	1,	11,	6,	17,	36,	23,	216
x6	x6	x6	x6	x6	x6	x6	x6

Alternate number is multiply by 6

Direction : (Q.6 to Q.10) : Identify the wrong number/letters in the series.

6. 25, 62, 122, 214, 341

- (1) 122
(2) 62
(3) 214
(4) 341

Answer (1)

Sol. 25, 62, 122, 214, 341

Pattern $n^3 - 2$
 $N = 3, 4, 5, 6, 7$

7. 1, 3, 7, 15, 31, 65, 127

- (1) 7 (2) 31
(3) 15 (4) 65

Answer (4)

Sol. 1, 3, 7, 15, 31, 65, 127

Pattern is $(X2) + 1$

8. -1, 2, 2, 5, 7, 10, 14, 17, 23, 26

- (1) 17
(2) 7
(3) 23
(4) 10

Answer (No option is correct)

Sol. In the Given pattern there is no wrong term

+3	+5	+7	+9	+3	+5	+7	+9	+3	+5
-1,	2,	2,	5,	7,	10,	14,	17,	23,	26
+3	+5	+7	+9	+3	+5	+7	+9	+3	+5

9. AD, EG, IJ, MM, QP, UP
 (1) EG (2) UP
 (3) QP (4) MM

Answer (2)

Sol.

	+3	+3	+3	+3	+4	
AD,	EG,	IJ,	MM,	QP,	UP	
+4	+4	+4	+4	+4		

 Ans : UP

10. Z8, W5, T2, Q8, N5, K3
 (1) K3 (2) T2
 (3) Q8 (4) Z8

Answer (1)

Sol. Z8, W5, T2, Q8, N5, K3

$$z - 26 \rightarrow 2 + 6 = 8$$

$$w - 23 \rightarrow 2 + 3 = 5$$

$$T - 20 \rightarrow 2 + 0 = 2$$

$$Q - 17 \rightarrow 1 + 7 = 8$$

$$N - 14 \rightarrow 1 + 4 = 5$$

$$K - 11 \rightarrow 1 + 1 = 2$$

11. 'Sea' is related with 'Waves'. Then 'Candle' is related to:
 (1) Rays (2) Wax
 (3) Stand (4) Melt

Answer (1)

Sol. Sea to waves

Candle → rays

12. Which set of number is like the given set ?
 (80, 60, 45)
 (1) (16, 12, 9)
 (2) (16, 12, 5)
 (3) (20, 15, 11)
 (4) (160, 120, 180)

Answer (1)

$$\text{Sol. } 80 \times \frac{3}{4} = 60 \times \frac{3}{4} = 45 = (80, 60, 45)$$

$$16 \times \frac{3}{4} = 12 \times \frac{3}{4} \times 9 = (16, 12, 9)$$

Direction : (Q.13 and Q.14) : First two terms are connected by some relationship. The same relationship is applicable for the next terms. Identify the suitable pair.

13. Square : Cube ::
 (1) Rectangle : Cuboid
 (2) Triangle : Square
 (3) Quadrilateral : Cuboid
 (4) Cuboid: Rectangle

Answer (1)

14. 82 : 9 ::
 (1) 5: 26 (2) 6: 37
 (3) 35: 6 (4) 26: 5

Answer (4)

$$\text{Sol. } 82 : 9 \rightarrow 9^2 + 1 = 82$$

$$26 : 5 \rightarrow 5^2 + 1 = 26$$

15. If 'tee see pee' means 'prepare fruit juice', 'see kee tee' means 'Juice is nice' and 'lee ree mee' means 'it is tall', which word means 'nice' ?
 (1) Ree (2) Mee
 (3) Kee (4) Pee

Answer (Incorrect data)

Sol. In the question, given data is incorrect.

16. In a certain code HONEY is written as HPPHC then FORGE is written as :
 (1) FPTJJ
 (2) FPTJI
 (3) FQTJI
 (4) FPSJI

Answer (2)

Sol.

	H	O	N	E	Y		F	O	R	G	E
+0	+1	+2	+3	+4		+0	+1	+2	+3	+4	
H	P	P	H	C		F	P	T	J	I	

17. If A = 2, T = 40 and ACT = 48 then TAKE is:
 (1) 68 (2) 58
 (3) 74 (4) 76

Answer (3)

Sol. A-2, T-40

$$\text{ACT} = 1 + 3 + 20 = (24) \times 2$$

$$\text{ACT} = 48$$

$$\text{TAKE} = 20 + 1 + 11 + 5 = (37) \times 2$$

$$\text{TAKE} = 74$$

Direction : (Q.18 to Q.21) : The diagram and the numbers/letters follow certain principle. Select the missing number/ letter indicated.

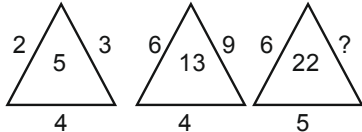
18. 
- (1) 8 (2) 12
(3) 11 (4) 33

Answer (No option is correct)

Sol. Same pattern will be followed only if 13 is replaced by 15 then answer will be option (1)

19.

4	5	6	7
6	18	28	?
10	7	8	7
- (1) 38 (2) 40
(3) 41 (4) 42

Answer (4)

- Sol.**

4	5	6	7	a
6	18	28	?	b
10	7	8	7	c

$$4^2 = 6 + 10 \quad a^2 = b + c$$

$$5^2 = 18 + 7$$

$$6^2 = 28 + 8$$

$$7^2 = ? + 7$$

↓

42

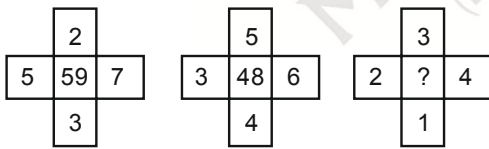
20. 
- (1) 22 (2) 26
(3) 28 (4) 30

Answer (1)

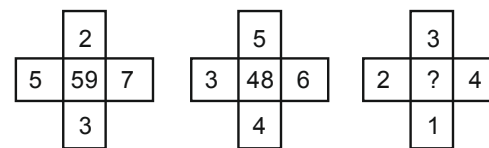
- Sol.** 
- $$7^2 + 5 + 2 + 3 = 59$$
- $$6^2 + 5 + 3 + 4 = 48$$
- $$4^2 + 3 + 2 + 1 = 22$$

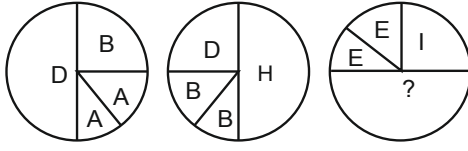
21. 
- (1) P
(2) Q
(3) R
(4) T

Answer (4)

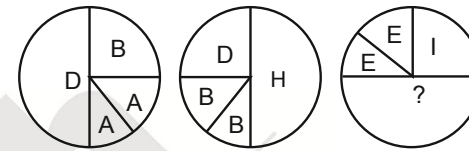
- Sol.** 
- $$D = B + A + A \quad H = D + B + B \quad ? = E + E + J$$
- $$4 = 2 + 1 + 1 \quad 8 = 4 + 2 + 2 \quad = 5 + 5 + 10 = 20 \quad T$$

Direction : (Q.22 to Q.24) : First two terms are connected by some relationship. The same relationship is applicable for the next terms in which one is blank space. Identify the blank space.

22. Tree : Plant :: Woman : ?
- (1) boy (2) child
(3) girl (4) mother

Answer (3)

23. Roof : floor :: ? : Dark
- (1) Tube light
(2) Bulb
(3) Bright
(4) Black

Answer (3)

24. 7 : 50 :: ? : 65
- (1) 9 (2) 64
(3) 8 (4) 11

Answer (3)

- Sol.** 7 : 50 → $7^2 + 1 = 49 + 1 = 50$
? : 65 → $64 + 1 = 8^2 + 1$
? = 8

25. Drama is related to Director in the same way as 'Magazine' is related to :

- (1) Story (2) Editor
(3) Reader (4) Printer

Answer (2)

26. The age of the father is twice the age of the elder son. Twelve years hence, the age of the father will be thrice that of the younger son. If the difference between the elder and younger son is 15, the age of the father is :

- (1) 21 (2) 42
(3) 63 (4) 84

Answer (2)

Sol. Age of father = 2 [Age of elder son] ... (1)

12yr hence age of father

= 3[Age of younger son] ... (2)

If differ of elder and younger = 15yr

Elder son – younger son = 15

(x) (y)

$x - y = 15 \Rightarrow x = 15 + y \rightarrow (3)$

(1) $\Rightarrow f = 2[15 + y] \Rightarrow f = 30 + 2y \rightarrow (4)$

(2) $\Rightarrow f + 12 = 3[y + 12] \rightarrow f + 12$

$= 3y + 36 \Rightarrow f = 3y + 24 \rightarrow (5)$

$\Rightarrow (4) = (5)$

$30 + 2y = 24 + 3y$

$\Rightarrow y = 6$

$\Rightarrow x = 15 + 6 = 21$

(1) $\Rightarrow f = 2(x) = 2(21) = 42$

\therefore Age of father = 42

27. In an examination, a student got thrice as many sums wrong as he got right. If he attended 120 problems in all, the number of problems incorrectly done is :

- (1) 90 (2) 30
(3) 40 (4) 60

Answer (1)

Sol. \therefore Suppose student got x sum right and 3x sums wrong

$\Rightarrow x + 3x = 120$

$4x = 120$

$x = 30$

\therefore Wrong sums = 90

28. The number of neither composite nor prime number in the set of Natural numbers is :

- (1) 2 (2) 3
(3) 1 (4) 0

Answer (3)

29. In a group of cows and hens, the number of legs are 16 more than thrice the number of heads. The possible number of cows and hens are respectively :

- (1) 20, 4
(2) 4, 20
(3) 18, 6
(4) 6, 18

Answer (1)

Sol. Number of cows = x, Number of hens = y

$4x + 2y = 3(x + y) + 16$

$4x + 2y = 3x + 3y + 16$

$x - y = 16$

So possibility

30. Which of the following statement is **correct** ?

- (1) The number of real numbers between 1 and 2 is same as 1 and 3.
(2) The first positive real number is 0.
(3) The non-negative integer starts with 1.
(4) The number of natural numbers is finite.

Answer (1)

31. If South becomes north-east and North becomes south-west then north-west becomes:

- (1) East
(2) West
(3) North
(4) South

Answer (4)

Sol. South \rightarrow North East

North \rightarrow South West

North West \rightarrow South

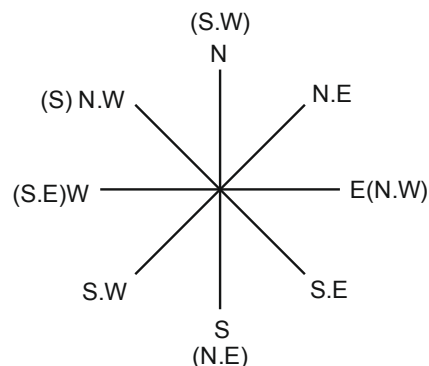

32. One evening during sunset, a person is standing facing a pole. The shadow of the pole fell exactly to his left. The person faces the direction :

- (1) South (2) East
(3) West (4) North

Answer (1)

Sol. Left (Shadow)

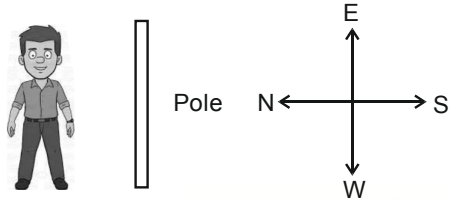

Right (Sun set)

Person facing south

33. The number of two digit combinations having 9 as at least one of the digits from the digit 0, 6, 9, 5, 4 is :

- (1) 9 (2) 12
(3) 6 (4) 8

Answer (4)

Sol. 90, 96, 99, 95, 94 – 1st digit '9'

69, 59, 49 – 2nd digit '9'

Total – 8

34. In a row of students, a boy is 12th from the left end and 18th from the right end. The total number of students is a/ an :

- (1) Prime number (2) Composite number
(3) Even number (4) Can't be predicted

Answer (1)

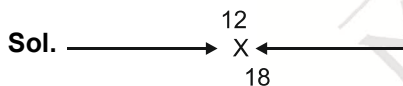

$$\text{Total strength} = 12 + 18 - 1 = 29$$

35. Six different bells in a tower toll at the intervals of 9 sec, 12 sec, 15 sec, 18 sec, 21 sec and 24 sec respectively. If all of them toll at 6 am, the next time they toll together is :

- (1) 7.42 am
(2) 6.42 am
(3) 8.00 am
(4) 9.00 am

Answer (2)

Sol. $\begin{array}{r} 3 \overline{) 9, 12, 15, 18, 21, 24} \\ \underline{3, 4, 5, 6, 7, 8} \\ 2 \overline{) 1, 4, 5, 2, 7, 8} \\ \underline{1, 2, 5, 1, 7, 4} \\ \underline{ 1, 1, 5, 1, 7, 2} \end{array}$

$$\begin{aligned} \text{L. C. M} &= 3 \times 3 \times 2 \times 2 \times 5 \times 7 \times 2 \\ &= 9 \times 4 \times 10 \times 7 \\ &= 360 \times 7 \\ &= 2520 \text{ second} \\ &= 42 \text{ min} \end{aligned}$$

$$\therefore 6 : 42 \text{ min}$$

36. In the series 5 8 6 4 9 8 5 4 2 6 7 9 8 1 3 5 4 2, the number of pairs of alternate numbers have difference 3, is

- (1) 4 (2) 2
(3) 3 (4) 1

Answer (1)

Sol. $5 \ 8 \ 6 \ 4 \ 9 \ 8 \ 5 \ 4 \ 2 \ 6 \ 7 \ 9 \ 8 \ 1 \ 3 \ 5 \ 4 \ 2$
 $\quad \quad \quad \underbrace{\quad \quad \quad}_3 \quad \underbrace{\quad \quad \quad}_3 \quad \underbrace{\quad \quad \quad}_3 \quad \underbrace{\quad \quad \quad}_3$

$$\text{Total} = 4$$

37. The arrangement of alphabetical order of the words:

- (a) Music (b) Monk
(c) Minimum (d) Maximum
(1) (d), (c), (b), (a) (2) (a), (c), (d), (b)
(3) (d), (c), (a), (b) (4) (d), (a), (c), (b)

Answer (1)

38. Select the combination of number so that the letters arranged accordingly will form a meaningful word :

R T F I U

1 2 3 4 5

- (1) 3, 1, 5, 4, 2 (2) 1, 3, 5, 4, 2
(3) 3, 5, 1, 4, 2 (4) 3, 2, 5, 4, 1

Answer (1)

Sol. F R U I T

1 1 1 1 1
3 1 5 4 2

39. The letter ninth to the left of seventeenth letter from the right end of the English alphabets is :

- (1) B (2) Z
(3) Y (4) A

Answer (4)

Sol. ⇒ Ninth to the left of seventeenth letter from Right End

Means $9 + 17 = 26$ Letter from Right End i.e, 'A'

40. A group of letters is given which are numbered 1, 2, 3, 4, 5, 6. Choose the combination of numbers, so that letters arranged form a meaningful word.

R O P N E S

1 2 3 4 5 6

- (1) 3, 5, 1, 6, 2, 4 (2) 1, 3, 5, 6, 2, 4
(3) 3, 5, 6, 1, 2, 4 (4) 3, 5, 2, 1, 6, 4

Answer (1)

Sol. PERSON
| | | | | |
3 5 1 6 2 4

Direction : (Q.41 to Q.45) : Select from the given diagrams (a), (b), (c) or (d) the one that illustrates the relationship among given classes.

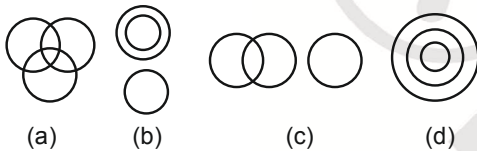

41. Birds, Tigers, Peacocks :

- (1) (b) (2) (c)
(3) (a) (4) (d)

Answer (1)

42. Languages, Tamil, Telugu :

- (1) (a) (2) (b)
(3) (d) (4) none of these

Answer (4)

43. Football fans, Cricket fans, Kabadi fans :

- (1) (b) (2) (c)
(3) (a) (4) (d)

Answer (3)

44. Human-beings, Indians, Tamilians :

- (1) (a) (2) (d)
(3) (c) (4) (b)

Answer (2)

45. Tamil Nadu, Punjab, Haryana :

- (1) (c) (2) (a)
(3) (d) (4) (b)

Answer (1)

Direction : (Q.46 to Q.50) : In the following figure, Rectangle, Square, Circle and Triangle represent the regions of rice, gram, maize and wheat cultivation respectively. On the basis of the given figure answer the questions.

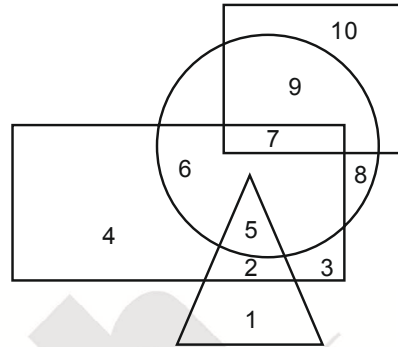

46. Which region cultivates all the four ?

- (1) 7 (2) 5
(3) 6 (4) None

Answer (4)

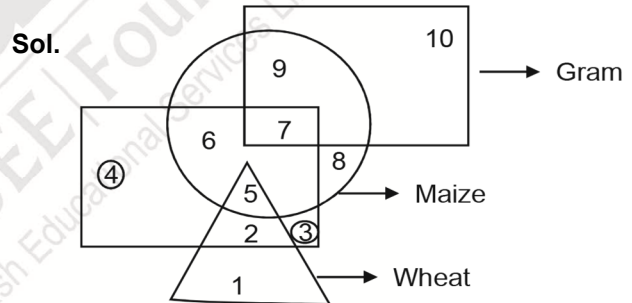

47. Which region cultivates only rice?

- (1) 6 (2) 4
(3) 5 (4) 3

Answer (No option is correct)

Sol. Region cultivates only rice will be represented by 4 and 3

Hence no option is correct

48. Which region cultivates wheat and maize?

- (1) 5 (2) 2
(3) 6 (4) 7

Answer (1)

49. Which region cultivates all except rice ?

- (1) 1, 8, 9, 10 (2) 2, 8, 9, 10
(3) 1, 7, 8, 9 (4) 1, 4, 7, 9

Answer (1)

50. Which region cultivates gram only ?

- (1) 9
- (2) 7
- (3) 8
- (4) 10

Answer (4)

Direction : (Q.51 and Q.52) : Read the given statements and answer the questions 51 and 52.

- (i) $A + B$ means 'A is the father of B'
- (ii) $A - B$ means 'A is the wife of B'
- (iii) $A \times B$ means 'A is the brother of B'
- (iv) $A \div B$ means 'A is the daughter of B'

51. $A - B + C$ means:

- (1) A is the mother of C
- (2) C is the mother of A
- (3) B is the mother of C
- (4) C is the mother of B

Answer (1)

Sol. $A - B + C$

52. $A \times B \div C$:

- (1) C is mother of B
- (2) B is mother of C
- (3) A is mother of C
- (4) A is mother of B

Answer (1)

Sol. $A \times B \div C$

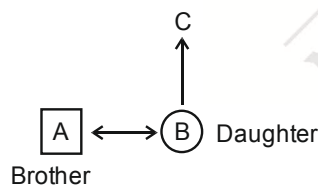

'C' Gender unknow

Direction : (Q.53 to Q.55) : Study the following information and answer the questions (53 to 55) given below. There is a group of five persons A, B, C, D and E.

- (i) A, B and C are Tall
- (ii) A, D and E are Educated
- (iii) D, C and E are Urban
- (iv) A, B and E are Hardworking

53. Which of the following persons is neither educated nor hardworking ?

- (1) A
- (2) C
- (3) D
- (4) E

Answer (2)

Sol. (Direction 53 to 55)

	Tall	Eudcated	Urban	Hardworking
A	Y	Y		Y
B	Y			Y
C	Y		Y	
D		Y	Y	
E		Y	Y	Y

54. Which of the following persons is neither urban nor educated but is hardworking?

- (1) A
- (2) C
- (3) B
- (4) D

Answer (3)

55. Which of the following persons is either tall or hardworking?

- (1) A, B, C, E
- (2) all
- (3) A, B, D, E
- (4) A,B,C,D

Answer (1)

56. How many numbers from 1 to 100 are there each of which is exactly divisible by 6 but also contain 6 as a digit in it ?

- (1) 6
- (2) 4
- (3) 5
- (4) 7

Answer (3)

Sol. 6, 12, 18, 24, 30
36, 42, 48, 54, 60
66, 72, 78, 84, 90
96

} Divisible by '6'

\Rightarrow Contains '6' as digit

6, 36, 60, 66, 96

\therefore Total : 5

Direction : (Q.57 and Q.58) : Five boys P, Q, R, S and T took part in a race. R finished before T but behind S. P finished before Q but behind T.

57. Who won the race?

- (1) Q
- (2) P
- (3) R
- (4) S

Answer (4)

Sol. T S
P R
Q T

∴ 1 2 3 4 5
S R T P Q

58. Who got the last place ?

- (1) Q (2) S
(3) P (4) T

Answer (1)

Sol. T S
P R
Q T

∴ 1 2 3 4 5
S R T P Q

Direction : (Q.59 and Q.60) : Arrange the given words in a meaningful sequence and choose the most appropriate sequence from the given alternatives.

59. (a) appendix (b) contents
(c) chapters (d) introduction
(1) (a), (c), (b), (d) (2) (a), (b), (c), (d)
(3) (d), (c), (b), (a) (4) (c), (d), (a), (b)

Answer (2)

60. (a) Protect (b) Relief
(c) Flood (d) Rain
(1) (c), (d), (a), (b) (2) (c), (a), (d), (b)
(3) (a), (b), (c), (d) (4) (d), (c), (a), (b)

Answer (4)

If '−' means '×', '×' means '+', '+' means '÷' and '÷' means '−' then answer the question 61 and 62.

61. $8 + 4 - 3 \times 2 \div 1 =$
(1) 8 (2) 7
(3) 22 (4) 21

Answer (2)

Sol. $8 + 4 - 3 \times 2 \div 1 = ?$

Changes

$$= \frac{8}{4} \times 3 + 2 - 1$$

$$= 2 \times 3 + 2 - 1$$

$$\Rightarrow 6 + 2 - 1$$

$$= 7$$

62. $12 \times 8 + 2 - 4 \div 6 =$
(1) 7 (2) 16
(3) 18 (4) 8

Answer (No option is correct)

Sol. $12 \times 8 + 2 - 4 \div 6$

Changes

$$= 12 + \frac{8}{2} \times 4 - 6$$

$$= 12 + 4 \times 4 - 6$$

$$= 12 + 16 - 6$$

$$= 22$$

No option is correct

63. If '−' means '÷', '+' means '×', '÷' means '−', '×' means '+' then which of the following is correct ?
(1) $36 - 12 \times 6 \div 3 + 3 = 60$
(2) $52 \div 4 + 5 \times 8 - 2 = 36$
(3) $42 - 8 \times 3 \div 4 + 3 = 38$
(4) $49 - 10 + 8 \div 4 + 4 = 40$

Answer (2)

Sol. $52 \div 4 + 5 \times 8 - 2$

Changes

$$52 - 4 \times 5 + 8 / 2 = 36 = > 52 - 4 \times 5 + 4 = 36$$

$$\Rightarrow 52 - 20 + 4 = 36 = > 32 + 4 = 36$$

64. If $8 * 1 = 81$, $9 * 1 = 100$ then $7 * 1 =$ is :
(1) 50 (2) 64
(3) 51 (4) 48

Answer (2)

Sol. $8 * 1 = 81$ $9 * 1 = 100$ $7 * 1 = ?$
 $(8 + 1)^2 = 81$ $(9 + 1)^2 = 100$ $(7 + 1)^2 = 64$

65. If $37 + 42 = 16$, $43 + 54 = 16$, $25 + 34 = 14$ then $65 + 35 =$
(1) 100 (2) 91
(3) 18 (4) 19

Answer (4)

Sol. $37 + 42 = 16$ $43 + 54 = 16$ $25 + 34 = 14$
↓
 $3 + 7 + 4 + 2 = 16$ $4 + 3 + 5 + 4 = 16$ $2 + 5 + 3 + 4 = 14$
 $65 + 35$
 $\Rightarrow 6 + 5 + 3 + 5 = 19$

Direction : (Q.66 and Q.67) : Choose the best alternative as the answer.

66. If $A + B > A + C$ and $A + B > A - C$ then

- (1) $B > 0$ (2) $A > 0$
(3) $C > 0$ (4) None of these

Answer (1)

Sol. $A + B > A + C$ & $A + B > A - C$
 $B - C > 0$ $B + C > 0$
 $\Rightarrow B > 0$

67. Danger always involves:

- (1) Fear (2) Help
(3) Attack (4) Enemy

Answer (1)

68. When the time is 4.20 the angle between the hands of the clock is :

- (1) 0° (2) 15°
(3) 20° (4) 10°

Answer (4)

Sol. 4 : 20

$$\Rightarrow \left| 30H - \frac{11}{2}m \right| = \theta$$

$$\Rightarrow \left| 120 - \frac{11}{2} \times 20 \right| = \theta$$

$$\Rightarrow |120 - 110| = \theta \Rightarrow \theta = 10$$

Direction : (Q.69 to Q.73) : Read the following information carefully and answer the questions given below :

- (i) There is a group of 5 persons P, Q, R, S and T.
(ii) Among them there is an Agriculturist, a Teacher, a Lawyer, a Doctor and an Editor by profession.
(iii) Three of them P, R and the Editor prefer meals to tiffin and two of them Q and the Lawyer prefer tiffin to meals.
(iv) The doctor, S and P are friends to one another but two of these prefer tiffin to meals.
(v) Agriculturist is R's Brother.

69. Who is Doctor ?

- (1) Q (2) R
(3) S (4) T

Answer (1)

Sol. Meals to tiffin

P - Agriculturist

R - Teacher

The Editor - T

Tiffin to meals

Q - The doctor

The lawyer (S)

70. Who is Agriculturist?

- (1) T (2) S
(3) R (4) P

Answer (4)

Sol. Meals to tiffin

P - Agriculturist

R - Teacher

The Editor - T

Tiffin to meals

Q - The doctor

The lawyer (S)

71. Which of the following groups prefer tiffin?

- (1) P, R, T (2) P, R
(3) Q, S (4) P, S

Answer (3)

Sol. Meals to tiffin

P - Agriculturist

R - Teacher

The Editor - T

Tiffin to meals

Q - The doctor

The lawyer (S)

72. Who is Teacher?

- (1) Q (2) R
(3) P (4) T

Answer (2)

Sol. Meals to tiffin

P - Agriculturist

R - Teacher

The Editor – T

Tiffin to meals

Q - The doctor

The lawyer (S)

73. Who is the Editor?

(1) T

(2) P

(3) Q

(4) S

Answer (1)

Sol. Meals to tiffin

P - Agriculturist

R - Teacher

The Editor – T

Tiffin to meals

Q - The doctor

The lawyer (S)

Direction : (Q.74 and Q.75) : In each of the questions given below, two statements I and II are followed by the conclusions numbered 1 and 2. Read the conclusion and give the answer.

74. Statement (I) : All women are mothers

(II) : All mothers are sisters

Conclusion (1) : All women are sisters

(2) : Some women are not sisters

(1) Only conclusion (1) follows

(2) Only conclusion (2) follows

(3) Either conclusion (1) or (2) follow

(4) Neither conclusion (1) nor (2) follows

Answer (1)

Sol.

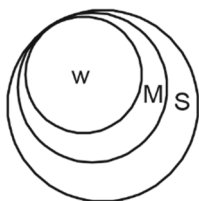

75. Statement (I) : Some books are Tables

(II) : Some Tables are pencils

Conclusion (1) : All books are pencils

(2) : Some pencils are books

(1) Only conclusion (1) follows

(2) Only conclusion (2) follows

(3) Either conclusion (1) or (2) follow

(4) Neither conclusion (1) nor (2) follows

Answer (4)

Sol.



Direction : (Q.76 to Q.80) : Out of the four figures (1), (2), (3), (4) given in each problem, three are similar in a certain way. One figure is not like other three. Select that figure.

76.

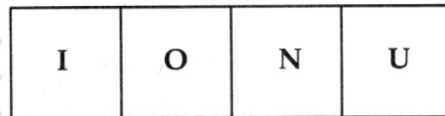

(1)

(2)

(3)

(4)

Answer (3)

Sol.

77.

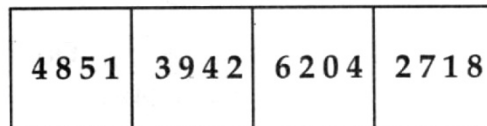

(1)

(2)

(3)

(4)

Answer (3)

Sol. Sum of digits

$$4 + 8 + 5 + 1 = 18$$

$$3 + 9 + 4 + 2 = 18$$

$$6 + 2 + 0 + 4 = 12$$

$$2 + 6 + 1 + 8 = 18$$

78.

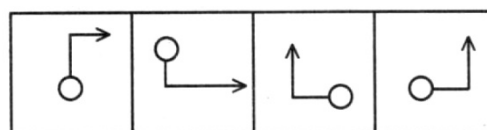

(1)

(2)

(3)

(4)

Answer (2)

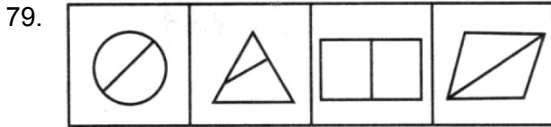

(1) (2) (3) (4)

Answer (2)

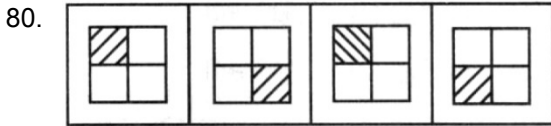

(1) (2) (3) (4)

Answer (3)

Direction : (Q.81 to Q.85) : In each of the following questions find the answer figures (1), (2), (3) or (4) which would continue the given series of four figures (A), (B), (C) and (D).

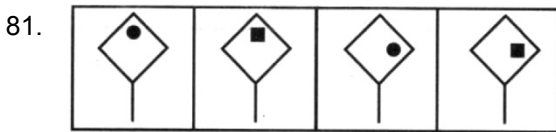

(A) (B) (C) (D)

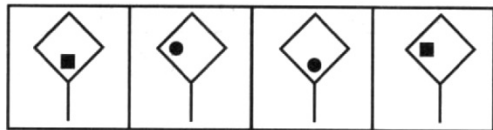

(1) (2) (3) (4)

Answer (3)

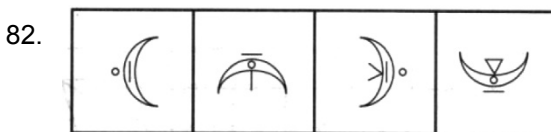

(A) (B) (C) (D)

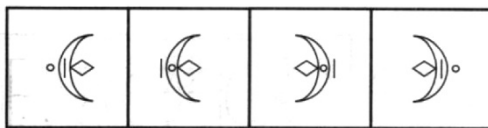

(1) (2) (3) (4)

Answer (1)

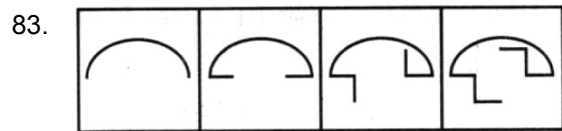

(A) (B) (C) (D)

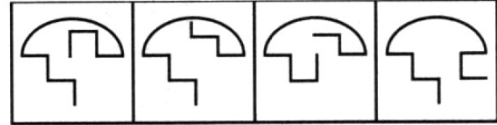

(1) (2) (3) (4)

Answer (2)

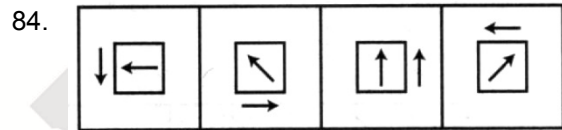

(A) (B) (C) (D)

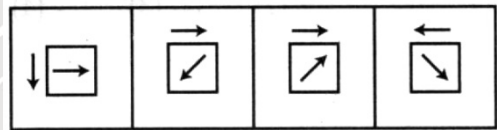

(1) (2) (3) (4)

Answer (1)

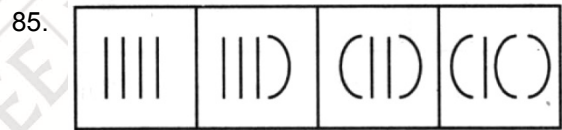

(A) (B) (C) (D)



(1) (2) (3) (4)

Answer (2)

Direction : (Q.86 to Q.88) : Figures A and B are related in some manner. Find the same relationship between figures C and D by choosing the alternatives (1), (2), (3) or (4) to replace the figure in D.



(A) (B) (C) (D)



(1) (2) (3) (4)

Answer (1)

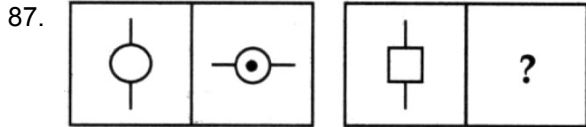

- (A) (B) (C) (D)

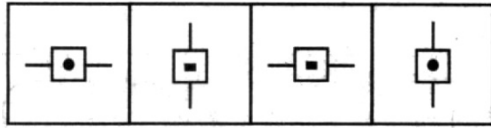

- (1) (2) (3) (4)

Answer (3)

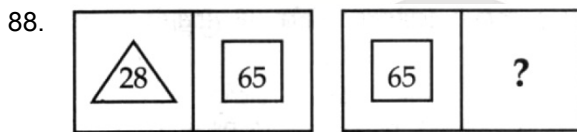

- (A) (B) (C) (D)

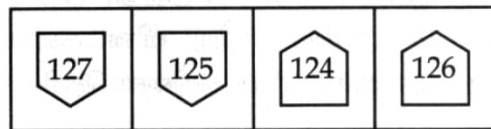



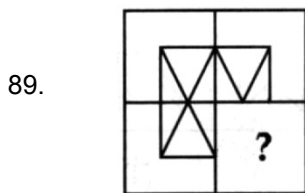

- (1) (2) (3) (4)

Answer (4)





Direction : (Q.89 and Q.90) : Identify the missing portion to complete the given figure from the alternatives (1), (2), (3) and (4).

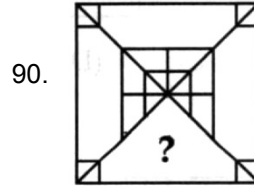

- (1)  (2)  (3)  (4) 

Answer (3)



- (1)  (2)  (3)  (4) 

Answer (2)

91. Find the number of quadrilaterals in the figure :

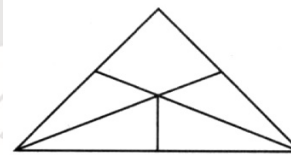

- (1) 0 (2) 2 (3) 3 (4) 4

Answer (4)

92. Find the number of triangles in the figure :

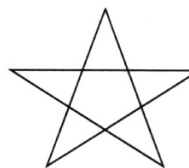

- (1) 8 (2) 7 (3) 5 (4) 10

Answer (4)

93. When a box is unfolded, the figure looked like the given one. What are the faces opposite to 4 and 5 respectively ?



- (1) 2, 6
- (2) 6, 2
- (3) 1, 3
- (4) 2, 4

Answer (2)

94. A die is thrown three times and its three different positions are given below. Find the number on the face opposite to 3.

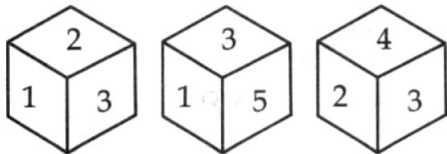

- (1) 6
- (2) 5
- (3) 4
- (4) 2

Answer (1)

Sol.

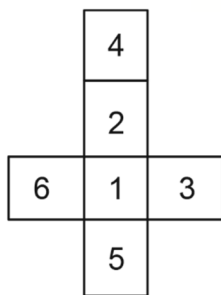

95. The water image of PENCIL is :

- (1) ꞆENICꞆ (2) ꞆENICꞆ
- (3) ꞆENICꞆ (4) ꞆENICꞆ

Answer (2)

96. The water image of 4 5 6 7 8 is :

- (1) 4 5 6 7 8 (2) 4 5 6 7 8
- (3) 4 5 6 7 8 (4) 4 5 6 7 8

Answer (1)

97. The mirror image of PROPER is:

- (1) ꞆROꞆER (2) ꞆROꞆER
- (3) ꞆROꞆER (4) ꞆROꞆER

Answer (4)

98. The mirror image of the given diagram :



- (1) (2)
- (3) (4)

Answer (2)

99. In a hockey tournament each of 5 teams will play other team exactly once. The number of matches will be played is:

- (1) 5 (2) 4
- (3) 20 (4) 10

Answer (4)

100. Which letter is midway between 22nd letter from the left and 21st letter from the right in English alphabets ?

- (1) N (2) M
- (3) L (4) O

Answer (1)

Sol. $\frac{1^{st}}{\text{left}} \rightarrow \frac{2^{nd}}{\text{Right}}$
 $\frac{2^{nd}}{\text{left}} \rightarrow \frac{21}{\text{Right}}$
 $22 + 6 = \frac{28}{2} = 14$
 'N'

110. If $\cos(A - B) = \frac{\sqrt{3}}{2}$ and $\sin(A + B) = 1$ then the value of A and B is :
- (1) 45° and 15°
 - (2) 30° and 15°
 - (3) 60° and 30°
 - (4) None of these

Answer (3)

Sol. $\cos(A - B) = \frac{\sqrt{3}}{2} = \cos 30^\circ$

$\sin(A + B) = 1 = \sin 90^\circ$

$A + B = 90^\circ$

$A - B = 30^\circ$

111. Which statement is true ?
- (1) A triangle can have two right angles
 - (2) Each of the angles of a triangle can be less than 60°
 - (3) Each of the angles of a triangle can be greater than 60°
 - (4) Each of the angles of a triangle can be equal to 60°

Answer (4)

112. If the diagonals of a rhombus are 18 cm and 24 cm, then its side is :

- (1) 16 cm
- (2) 15 cm
- (3) 20 cm
- (4) 17 cm

Answer (2)

Sol.

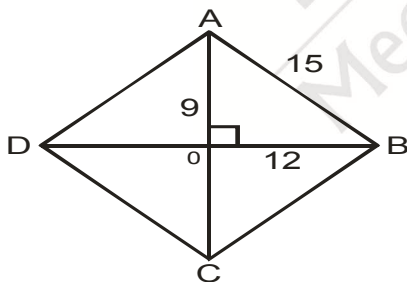

113. Which of the following numbers will completely divide $4^{61} + 4^{62} + 4^{63} + 4^{64}$?
- (1) 3
 - (2) 10
 - (3) 11
 - (4) 13

Answer (2)

Sol. $4^{60}[4 + 4^2 + 4^3 + 4^4] = 4^{60} \times 340$

114. The diagonal of a rectangle is $\sqrt{41}$ cm and its area is 20 cm^2 . The perimeter of a rectangle must be :

- (1) 9 cm
- (2) 18 cm
- (3) 20 cm
- (4) 41 cm

Answer (2)

Sol. $l^2 + b^2 = 41$

$lb = 20$

$(l, b) = (5, 4)$

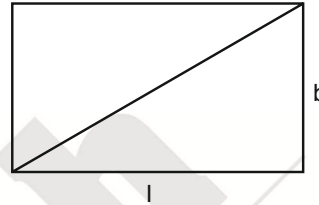

115. The scientific notation of 108000000 km is :

- (1) 1.08000000 km
- (2) 10.80×10^6 km
- (3) 1.08×10^8 km
- (4) 1.08×10^9 km

Answer (4)

116. Cards marked from 1 to 50 are placed in the box and mixed thoroughly, a card is drawn at random from the box. What is the probability of this card to be a multiple of 5?

- (1) $\frac{1}{5}$
- (2) 0
- (3) $\frac{1}{25}$
- (4) 1

Answer (1)

Sol. $P(A) = \frac{10}{50} = \frac{1}{5}$

117. The graph of the line $x - y = 0$ passes through the point

- (1) (2, 3)
- (2) (3, 4)
- (3) (5, 6)
- (4) (0, 0)

Answer (4)

118. If $(9x + 7), (2x + 9)$ are the factors of a quadratic polynomial, then the co-efficient of x is :

- (1) 9
- (2) 2
- (3) 18
- (4) 95

Answer (4)

Sol. $(9x + 7) \cdot (2x + 9)$

$18x^2 + 95x + 63$

- (a) Formation of real and inverted images of objects
(b) Controls the amount of light entering the pupil
(c) Pathway of the light to retina
(d) Refracts or bends the light onto the lens
- (i) Pupil
(ii) Cornea
(iii) Iris
(iv) Retina
- (1) (a)-(iv), (b)-(iii), (c)-(i), (d)-(ii)
(2) (a)-(iv), (b)-(iii), (c)-(ii), (d)-(i)
(3) (a)-(iii), (b)-(iv), (c)-(ii), (d)-(i)
(4) (a)-(ii), (b)-(i), (c)-(iii), (d)-(iv)

Answer (1)

Sol. Conceptual

128. Pick out the correct pair/pairs:

- (a) Radiation - Heat is transferred in the form of waves. It can occur even in vacuum
(b) Conduction – Transfer of heat in fluids. It doesn't take place in vacuum
(c) Convection – Transfer of heat in solids. It can occur in vacuum
- (1) (a) only
(2) (b) and (c) only
(3) (a) and (c) only
(4) (c) only

Answer (1)

Sol. Convection is a process of transferring heat by movement of particles and conduction can take place in solids.

129. Correct the given statement

The Spectral lines having frequency equal to the incident ray frequency is called 'Raman Lines'

- (1) Rayleigh Lines (2) Stokes Lines
(3) Anti Stokes Lines (4) Tyndall Effect

Answer (1)

Sol. Conceptual

130. The only moon in the solar system that moves in the opposite direction to the direction in which its planet spins?

- (1) Sputnik (2) Titan
(3) Ganymede (4) Triton

Answer (4)

Sol. Neptune's moon-Triton

131. The reason for using red light in traffic signals to stop vehicles.

- (1) Red light has shorter wavelength
(2) Red light has longer wavelength
(3) Red light is very bright and attractive
(4) Red light has highest angle of refraction

Answer (2)

Sol. Conceptual

132. Which one of the following is not related to Joule's Law of Heating?

- (1) $H = I^2 RT$
(2) $H = VIt$
(3) $H = VIRt^2$
(4) $H = VQ$

Answer (3)

Sol. $H = I^2 RT$

$$H = \frac{V^2}{R} t$$

$$H = VIt$$

$$H = VQ \text{ but not } H = VIRt^2$$

133. Convert 1 Kilowatt into Horsepower:

- (1) 1.43 HP
(2) 746000 HP
(3) 1.34 HP
(4) 0.746 HP

Answer (3)

Sol. 1 H.P = 746 watt

$$\frac{1}{746} \text{ H.P} = 1 \text{ watt}$$

$$\frac{1000}{746} \text{ H.P} = 1 \text{ kW}$$

$$1.34 \text{ H.P} = 1 \text{ kW}$$

134. Pick the odd one out :

- (1) CCl_4
(2) NaCl
(3) CuCl_2
(4) CaCl_2

Answer (1)

Sol. Fact

135. Match the following :

- | | |
|--------------------------|--|
| (a) Tyndall Effect | (i) Separates blood cells from blood samples |
| (b) Brownian Movement | (ii) Separates different coloured dyes |
| (c) Centrifugation | (iii) Colloidal Particles Moves in zig-Zag direction |
| (d) Paper Chromatography | (iv) Not observed In true solution |
- (1) (a) – (iv), (b) – (iii), (c) – (i), (d) – (ii)
 (2) (a) – (iii), (b) – (iv), (c) – (i), (d) – (ii)
 (3) (a) – (iii), (b) – (i), (c) – (iv), (d) – (ii)
 (4) (a) – (i), (b) – (iii), (c) – (ii), (d) – (iv)

Answer (1)

Sol. Fact

136. The Law of Multiple Proportion was proposed by

- | | |
|-----------------|---------------------|
| (1) John Dalton | (2) Jeremias Richer |
| (3) Neil Bohr | (4) Rutherford |

Answer (1)

Sol. Fact

137. Assertion **(A)** : Bronze is an alloy.

Reason **(R)** : Alloy bears the characteristics of both metal and non - metal

- (1) Both **(A)** and **(R)** are correct.
 (2) Both **(A)** and **(R)** are wrong.
 (3) **(A)** is correct but **(R)** doesn't explain **(A)**
 (4) **(A)** is correct and **(R)** explains **(A)**

Answer (3)

Sol. Fact

138. Find the odd one out:

- | | |
|--------------------|---------------------|
| (1) Galvanization | (2) Bessemerisation |
| (3) Electroplating | (4) Anodizing |

Answer (2)

Sol. Fact

139. $2\text{PbO} + \text{C} \rightarrow 2\text{Pb} + \text{CO}_2$ is an example of _____ reaction.

- | | |
|---------------|-------------------|
| (1) Reduction | (2) Redox |
| (3) Oxidation | (4) Decomposition |

Answer (2)

Sol. Fact

140. The ratio of conc. HCl and conc. HNO_3 in 'King's Water' is“

- | | |
|-----------|-----------|
| (1) 4 : 1 | (2) 1 : 4 |
| (3) 3 : 1 | (4) 1 : 3 |

Answer (3)

Sol. Fact

141. Find the incorrect pair:

- | | |
|-------------------------|--------------------------------------|
| (1) Ammonium Hydroxide | – Removes grease stains from clothes |
| (2) Calcium Hydroxide | – White washing of building |
| (3) Sodium Hydroxide | – Manufacture of soap |
| (4) Magnesium Hydroxide | – Manufacture of fertilizer |

Answer (4)

Sol. Fact

142. Which one of the following resin codes in plastic items are unsafe ?

- | | |
|-------------|-------------|
| (1) 1, 2, 3 | (2) 3, 6, 7 |
| (3) 3, 4, 5 | (4) 5, 6, 7 |

Answer (2)

Sol. Fact

143. Which among the following is highly toxic and inflammable gas ?

- | | |
|-------------------|--------------------|
| (1) CO | (2) CO_2 |
| (3) CS_2 | (4) CaC_2 |

Answer (1)

Sol. CO and CO_2 are the only two gases given in the options, out of which CO is the most toxic.

144. The reason for unstability of nano particles :

- | | |
|----------------|---------------|
| (1) Hydrolysis | (2) Hydration |
| (3) Combustion | (4) Reduction |

Answer (3)

Sol. Fact

145. Occult fingerprints are made visible by the use of _____ which turns purple.

- (1) Cyanoacrylate (2) Potassium di-chromate
(3) Nin-hydrin (4) Silver nitrate

Answer (3)

Sol. Fact

146. Pick out the correct formula for blue vitriol :

- (1) $\text{CuSO}_4 \cdot 5\text{H}_2\text{O}$ (2) $\text{CuSO}_4 \cdot 7\text{H}_2\text{O}$
(3) $\text{CuSO}_4 \cdot 6\text{H}_2\text{O}$ (4) $\text{CuSO}_4 \cdot 9\text{H}_2\text{O}$

Answer (1)

Sol. Fact

147. When exposed to sunlight, parenchyma cells may develop chloroplasts and are known as _____

- (1) Collenchyma (2) Chromoplast
(3) Chlorenchyma (4) Aerenchyma

Answer (3)

Sol. Chlorenchyma

148. Give the correct equation of photosynthesis :

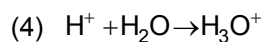
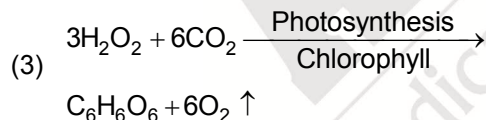
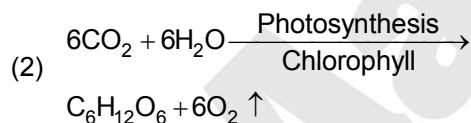
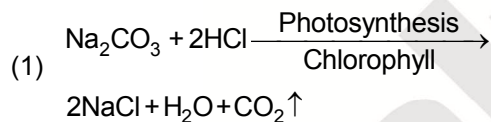

Answer (2)

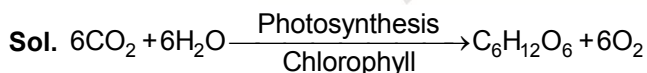

149. In some bacteria, outside the cell wall, there is an additional slimy protective layer called _____ made up of _____

- (1) Epiderm, monosaccharides
(2) DNA, mitochondria
(3) Capsule, polysaccharides
(4) Ribosomes, protein

Answer (3)

Sol. Capsule, Polysaccharides

150. Which is/are wrong about the adaption of hydrophytes ?

- (a) Air chambers provide mechanical support to plant
(b) Floating leaves have short leaf stalk
(c) Roots are poorly developed
(d) Submerged leaves are broad and big
(1) (a) only (2) (b) and (d) only
(3) (c) only (4) (a) and (c) only

Answer (2)

Sol. B and D only

151. 'AYUSH' refers to the systems of medicines of :

- (1) Unani (2) Siddha
(3) Ayurveda (4) All of the above

Answer (4)

Sol. All of the above

152. Father of Plant Anatomy :

- (1) Nehemiah Grew
(2) Robin Hill
(3) Sachs
(4) Kolliker

Answer (1)

Sol. Nehemiah Grew

153. **Assertion (A)** : The opening and closing of the stomata is due to change in turgidity of the guard cell :

Reason (R) : Evaporation of water in plants through stomata in leaves is called Transpiration.

- (1) (A) is correct but (R) is incorrect
(2) (A) is incorrect and (R) is correct
(3) (A) is correct but (R) doesn't explain (A)
(4) (A) is correct and (R) explains (A)

Answer (3)

Sol. (A) is correct but (R) doesn't explain (A)

154. When leech attaches itself to the body of the host, continuous supply of blood is maintained by the presence of _____ in its salivary gland.

- (1) Botryoidal tissue (2) Parapodia
(3) Hirudin (4) Setae

Answer (3)

Sol. Hirudin

155. Which acts as the 'Pacemaker of the Heart'?

- (1) Superior Venacava
- (2) Sino Atrial Node
- (3) Aortic Arch
- (4) Inferior Venacava

Answer (2)

Sol. Sino atrial node

156. Pick out the incorrect pair:

- (1) Rh factor – Landsteiner and Wiener
- (2) Circulation of Blood – Dacastello and Steini
- (3) AB Blood Group – William Harvey
- (4) Purkinje Fibre – Wilhelm His

Answer (2) & (3)

Sol. Circulation of Blood – Dacastello and Steini

AB Blood group – William Harvey

157. Find the odd one out:

- (1) Jejunum
- (2) Ileum
- (3) Caecum
- (4) Villi

Answer (3)

Sol. Caecum

158. Functions of Areolar connective tissue:

- (a) Joins skin to Muscle
 - (b) Fills space inside organs
 - (c) Provides shape to body and protects soft tissues and organs
 - (d) Helps to repair tissues after injury
- (1) (a) and (d) only
 - (2) (a), (b) and (c) only
 - (3) (a), (b) and (d) only
 - (4) All of the above

Answer (3)

Sol. (a), (b) and (d) only

159. Match the following:

- | | |
|-------------|--------------------------------------|
| (a) Trypsin | (i) Converts fat to smaller droplets |
| (b) Amylase | (ii) Acts on protein |
| (c) Bile | (iii) Digests fat |
| (d) Lipase | (iv) Breakdown starch to Maltose |
- (1) (a) – (ii), (b) – (i), (c) – (iii), (d) – (iv)
 - (2) (a) – (iii), (b) – (ii), (c) – (i), (d) – (iv)
 - (3) (a) – (ii), (b) – (iv), (c) – (i), (d) – (iii)
 - (4) (a) – (iv), (b) – (iii), (c) – (ii), (d) – (i)

Answer (3)

Sol. (a) – (ii), (b) – (iv), (c) – (i), (d) – (iii)

160. Which among the following has three chambered heart?

- | | |
|-----------|----------|
| (1) Tiger | (2) Rat |
| (3) Frog | (4) Fish |

Answer (3)

Sol. Frog

161. 'Never was so much owed by so many to so few' was the saying of:

- | | |
|-----------------------|--------------------|
| (1) Mussolini | (2) Hitler |
| (3) Winston Churchill | (4) Woodrow Wilson |

Answer (3)

162. Match the following:

- | | |
|-------------------------------|---|
| (a) Chinese Civilization | (i) Hammurabi's Law code |
| (b) Mesopotamian Civilization | (ii) Invention of Gun Powder |
| (c) Indus Valley Civilization | (iii) The Great Sphinx |
| (d) Egyptian Civilization | (iv) Developed the System of weights and measures |
- (1) (a)-(ii), (b)-(i), (c)-(iv), (d)-(iii)
 - (2) (a)-(ii), (b)-(iii), (c)-(iv), (d)-(i)
 - (3) (a)-(iv), (b)-(iii), (c)-(i), (d)-(ii)
 - (4) (a)-(i), (b)-(ii), (c)-(iii), (d)-(iv)

Answer (1)

163. Find the odd one out :

- | | |
|------------------|-------------------|
| (1) Kurinjipattu | (2) Pattinapalai |
| (3) Aingurunuru | (4) Nedunal Vadai |

Answer (3)

164. Identify the two cities in India which started declining in 1750's due to the increasing power of the European companies :

- (1) Madras and Bombay
- (2) Calcutta and Madras
- (3) Surat and Hoogly
- (4) Hoogly and Madras

Answer (3)

165. Utopia, a satire on political evil was written by :

- | | |
|---------------------|-----------------|
| (1) Sir Thomas More | (2) Cervantes |
| (3) Erasmus | (4) Machiavelli |

Answer (1)

166. **Assertion (A)** : Men disguised as Native American boarded the cargo vessel carrying tea and threw the tea overboard which was hailed as 'Boston Tea Party'.

Reason (R) : This incident led to the compromise between England and rebellious colonies.

- (1) Both (A) and (R) are correct
- (2) Both (A) and (R) are incorrect
- (3) (A) is correct but (R) does not explain (A).
- (4) (A) is correct and (R) explains (A).

Answer (1)

167. Arrange the following events in the chronological order:

- | | |
|----------------------|-----------------------|
| (a) Great Depression | (b) Battle of Marne |
| (c) Fascist party | (d) Battle of Jutland |
| (1) (a),(c),(b),(d) | (2) (b),(d),(c),(a) |
| (3) (d),(a),(c),(b) | (4) (a),(d),(b),(c) |

Answer (2)

168. The founder of Widow Remarriage Association:

- | | |
|-------------------|-------------------------|
| (1) M.G. Ranade | (2) Devendranath Tagore |
| (3) Jyotiba Phule | (4) Ayyankali |

Answer (1)

169. The number of member countries in UNO as in August 2019 :

- | | |
|---------|---------|
| (1) 190 | (2) 194 |
| (3) 192 | (4) 193 |

Answer (4)

170. The British Engineer who diverted the flow of Periyar River towards East and built a dam in Tamil Nadu :

- (1) Colonel Penny Cuick
- (2) Arthur Cotton
- (3) Robert Clive
- (4) Leopold II

Answer (1)

171. Find the incorrect statement :

- (1) Prakrit was the language spoken by the people during Mauryan period
- (2) Erythrean Sea refers to the water around the Red Sea.
- (3) The Cheras wore garlands made from the flowers of neem tree
- (4) Nalli, Ai, Kari and Pegan were Velirs.

Answer (3)

172. The difference in Local time between Gujarat and Arunachal Pradesh :

- (1) 1 hour 57 minutes 12 seconds
- (2) 1 hour 56 minutes 13 seconds
- (3) 1 hour 52 minutes 28 seconds
- (4) 1 hour 55 minutes 10 seconds

Answer (3)

173. Laccadive, Minicoy and Amindivi was renamed as 'Lakshadweep Island' in the year _____

- | | |
|----------|----------|
| (1) 1983 | (2) 1973 |
| (3) 1993 | (4) 1975 |

Answer (2)

174. Pick the odd one out :

- | | |
|-------------------|-----------------|
| (1) Wulur Lake | (2) Dal Lake |
| (3) Nainital Lake | (4) Chilka Lake |

Answer (4)

175. In India, bauxite deposits are abundantly found in :

- (1) Rajasthan
- (2) Odisha
- (3) Jammu and Kashmir
- (4) Andhra Pradesh

Answer (2)

176. The company which provides Helicopter services to Oil and Natural Gas Corporation :

- | | |
|---------------------|---------------|
| (1) Indian Airlines | (2) Air India |
| (3) Pawan Hans | (4) Vayu doot |

Answer (3)

177. Pick out the odd one out :

- | | |
|--------------|---------------|
| (1) Almora | (2) Shiwaliks |
| (3) Ranikhet | (4) Chamba |

Answer (2)

178. Match the following :

- | Rivers | Origin |
|--------------|----------------|
| (a) Tapti | (i) Amarkantak |
| (b) Narmada | (ii) Sihawa |
| (c) Godavari | (iii) Multai |
| (d) Mahanadi | (iv) Nasik |

- (1) (a)-(i),(b)-(iii),(c)-(iv),(d)-(ii)
- (2) (a)-(iii),(b)-(i),(c)-(iv),(d)-(ii)
- (3) (a)-(iv),(b)-(ii),(c)-(iii),(d)-(i)
- (4) (a)-(ii),(b)-(i),(c)-(iii),(d)-(iv)

Answer (2)

179. **Statement (I)** : 75% of Indian rainfall is received from South –west Monsoon.

Statement (II) : Tamil Nadu which is located in the leeward side receives abundant rainfall.

- (1) Statement (I) and (II) are correct
- (2) Statement (I) and (II) are incorrect
- (3) Statement (I) is correct and (II) is incorrect
- (4) Statement(I) is incorrect and (II) is correct

Answer (3)

180. _____ are long furrows which are formed when the joints of limestone rocks are corrugated by groundwater.

- (1) Sink holes
- (2) Caverns
- (3) Stalactites
- (4) Lappies

Answer (4)

181. Which among the following statement/ statements is/are correct ?

- (a) Troposphere is called 'Weather making layer'.
- (b) Exosphere is characterised by Aurora Australis and Aurora Borealis.
- (c) Thermosphere is called Ozonosphere.
- (d) Stratosphere is referred as Homosphere/ Heterosphere.

- (1) (a) and (b) only (2) (c) and (d) only
- (3) (a) only (4) (a), (b) and (c) only

Answer (1)

182. The significance of 'The Grand Banks' of New Foundland :

- (1) Mining activities (2) Oil drilling
- (3) Fishing ground (4) Mineral fuels

Answer (3)

183. _____ has been described as the 'Key to the Constitution'.

- (1) Fundamental Rights
- (2) Preamble
- (3) Directive Principles of State policy
- (4) Emergency Provision

Answer (2)

184. Which among the statements related to the qualification for the election as president is/are incorrect ?

- (a) he should be a citizen of India
- (b) He must have attained the age of twenty five years.
- (c) He must not hold any office of profit anywhere in India.
- (d) He must be a member of parliament or state Legislature.

- (1) (b) only (2) (a) and (c) only
- (3) (b) and (d) only (4) (a), (c) and (d) only.

Answer (3)

185. Who was India's 12th President?

- (1) Dr. A.P.J. Abdul Kalam
- (2) Mrs. Pratibha Patil
- (3) Dr. Pranab Mukherjee
- (4) Dr. K.R. Narayanan

Answer (2)

186. Who is appointed according to Article 216 ?

- (1) Chief Justice of High Court
- (2) Chief Justice of India
- (3) President
- (4) Prime Minister

Answer (1)

187. Rule 49 – O describes :

- (1) Transparency of the election proceedings.
- (2) Conduct of free and fair election.
- (3) Auditing procedure of the expenditure incurred by the contesting party
- (4) Not willing to elect any candidate.

Answer (4)

188. _____ is exempted from RTI Act :

- (1) Education Department
- (2) Intelligence Bureau
- (3) Municipal Corporation
- (4) Village Panchayat

Answer (2)

189. The new Panchayat Raj came into being in Tamil Nadu :

- (1) 1993 (2) 1994
- (3) 1995 (4) 1992

Answer (2)

190. Pick the odd one out :

- (1) Aruna Roy (2) Arvind Kejriwal
(3) Mithali Raj (4) Nikil Dev

Answer (3)

191. The first chairman of National Human Rights Commission :

- (1) Justice Fathima Bee
(2) Justice H.L. Dattu
(3) Justice J.S. Verma
(4) Justice Ranganath Misra

Answer (4)

192. Which writ upholds the fundamental rights of the citizen?

- (1) Certiorari (2) Mandamus
(3) Quo-Warranto (4) Prohibition

Answer (2)

193. POCSO Act was passed in the year :

- (1) 2012 (2) 2009
(3) 2010 (4) 2011

Answer (1)

194. Match the following :

- | | |
|----------------------------|--|
| (a) Net National Product | (i) GDP – Depreciation |
| (b) Gross Domestic Product | (ii) GNP – Depreciation |
| (c) Net Domestic Product | (iii) $GMP = C + I + G + (X - M) + NFIA$ |
| (d) Gross National Product | (iv) $GDP = C + I + G + (X-M)$ |

- (1) (a)-(i), (b)-(iii), (c)-(iv), (d)-(ii)
(2) (a)-(ii), (b)-(iv), (c)-(i), (d)-(iii)
(3) (a)-(iii), (b)-(ii), (c)-(iv), (d)-(i)
(4) (a)-(iv), (b)-(i), (c)-(ii), (d)-(iii)

Answer (2)

195. Pick the odd one out :

- (1) Iron
(2) Wood
(3) Coal
(4) Glass

Answer (4)

196. The author of the book “An Uncertain Glory” :

- (1) Jean Bodin
(2) Samuelson
(3) Adam Smith
(4) Amartya Sen

Answer (4)

197. The leading Solar producing state in India :

- (1) Telangana
(2) Karnataka
(3) Tamil Nadu
(4) Kerala

Answer (2)

198. The water consumed in production process of an agricultural and industrial product :

- (1) Virtual water (2) Rain water
(3) Hard water (4) Soft water

Answer (1)

199. An index used to measure the real development in an economy :

- (1) GDP (2) HDI
(3) IIP (4) CPI

Answer (2)

200. The Noble prize winner in Economics in 2018 :

- (1) Amartya Sen
(2) Richard Thaler
(3) William D. Nordhaus and Paul M. Romer
(4) Oliver Hart and Bengt Holmstorm

Answer (3)

