



# Aakash

## Medical | IIT-JEE | Foundations

(Divisions of Aakash Educational Services Pvt. Ltd.)

Regd. Office : Aakash Tower, 8, Pusa Road, New Delhi-110005

Ph.: 011-47623456 Fax : 011-47623472

Time : 3 Hours

# Answers & Solutions

Max. Marks : 200

*for*

## NTSE (Stage-I) 2017-18

### INSTRUCTIONS TO CANDIDATES

- Use blue/black ball point pen only. There is no negative marking.
- This test booklet contains 200 questions of one mark each. All the questions are compulsory.
- Part-I : MAT : 1 - 50 questions  
Part-II : Language : 1 - 50 questions  
Part-III : SAT : 1 - 100 questions
- Answer each question by darkening the one correct alternative among the four choices on the OMR Sheet with blue/black ball point pen.

Example :

Q. No.	Alternatives
Correct way :	1    ①   ②   ●   ④
Q. No.	Alternatives
Wrong way :	1    ⊗   ⊕   ⊖   ⊙

Student must darkening the right oval only after ensuring correct answer on OMR Sheet.

- Disparity in mentioning (SC, ST & PH) in application form and OMR Sheet can make your candidature invalid.
- Students are not allowed to scratch/ alter/ change out an answer once marked on OMR Sheet, by using white fluid/ eraser/ blade/ tearing/ wearing or in any other form.
- Separate Sheet has been provided for rough work in this test booklet.
- Please handover the OMR Sheet to the invigilator before leaving the Examination Hall.  
\*Take all your question booklets with you.
- Darken completely the ovals of your answers on OMR Sheet in the time limit allotted for that particular paper.
- Your OMR Sheet will be evaluated through electronic scanning process. Incomplete and incorrect entries may render your OMR Sheet invalid.
- Use of electronic gadgets, calculator, mobile etc., is strictly prohibited.

**PART-I : MENTAL ABILITY TEST (MAT)**

1. In the given equation which set of signs among the alternative replace the symbols  $\alpha$  and  $\beta$  respectively to make it meaningful ?

- (1) + and -                      (2)  $\times$  and -  
(3)  $\times$  and +                      (4) - and +

**Answer (4)**

**Sol.**  $93 \alpha 63 \div 21 - 23 \beta 43 = 110$

$93 \alpha 3 - 23 \beta 43 = 110$

If  $\alpha = -$  and  $\beta = +$  then

$93 - 3 - 23 + 43 = 110$  is correct

LHS = RHS

2. Which one of the following equations is not meaningful by substituting the set of mathematical signs (+,  $\times$ , =,  $\div$ ) sequentially in them?

- (1)  $10 * 14 * 5 * 160 * 2$   
(2)  $14 * 16 * 3 * 180 * 3$   
(3)  $12 * 15 * 4 * 144 * 2$   
(4)  $16 * 18 * 2 * 156 * 3$

**Answer (2)**

**Questions (3 to 4)**

**Direction:** Compare column-I and column-II to answer the given questions:

**Column-I**

- (i) 120  
(ii) 150  
(iii) 180  
(iv) 200

**Column-II**

- a.  $10n^2 + 10n$   
b.  $3n^3 + 3$   
c.  $2n^2 + 2n$   
d.  $n^3 + 3n$   
e.  $n^2 + n^2/2$   
f.  $4n^3 + 4n$

3. Which one of the given rules in column-II the number 200 follows?

- (1)  $2n^2 + 2n$                       (2)  $3n^3 + 3$   
(3)  $10n^2 + 10n$                       (4)  $n^3 + 3n$

**Answer (3)**

**Sol.**  $f(n) = 10(n^2) + 10n$

If  $n = 4$

$f(n) = 10(4)^2 + 10 \times 4 = 200$

4. Which number in column-I follows the rule  $(4n^3 + 4n)$ ?

- (1) 120                                      (2) 150  
(3) 180                                      (4) 200

**Answer (1)**

**Sol.**  $f(n) = 4n^3 + 4n$

If  $n = 3$ ;  $f(n) = 4 \times 27 + 12$   
 $= 108 + 12 = 120$

**Questions (5 - 6):**

**Directions:** Find the correct water images for the following problem figures from the given alternatives.

5.

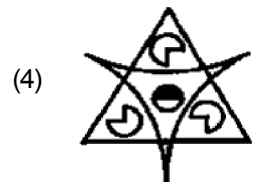
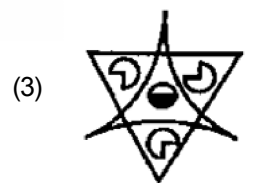
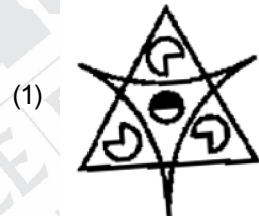
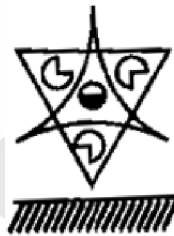

**Answer (2)**







(3) 1200

(4) 1400

**Answer (2)**

**Sol.**  $66 \times 6 + 4$

$$396 + 4 = 400$$

$$166 \times 6 + 4$$

$$996 + 4 = 1000$$

21. SAMOHT : SINNZT :: RELHEM : ?

(1) LFGMDS

(2) LFGMDS

(3) SFMIFN

(4) RDKGDL

**Answer (1)**

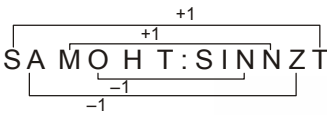
**Sol.** 

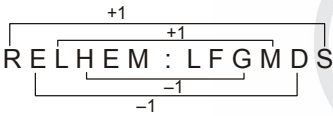

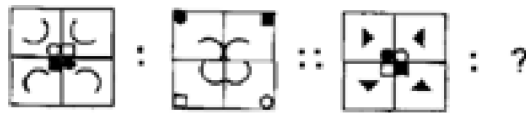
22. 

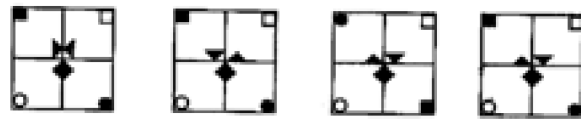

(1)

(2)

(3)

(4)

**Answer (4)**

**Sol.** All elements get diagonally interchanged.

23. 



(1)

(2)

(3)

(4)

**Answer (3)**

**Sol.** Number of sides of polygon =  $7 - 1 = 6$

Outside = 3 curves out & 3 curves in + 1 straight

$$3 = \frac{\text{Number of sides of Hexagon}}{2}$$

**Direction:** Find the wrong number in the given series.

24. 200, 300, 500, 900, 1800, 3300

(1) 3300

(2) 1800

(3) 900

(4) 500

**Answer (2)**

**Sol.** Differences

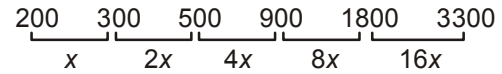

where  $x = 100$

$$2 \times 2 - 1 = 3$$

$$3 \times 2 - 1 = 5$$

$$5 \times 2 - 1 = 9$$

$$9 \times 2 - 1 = 17 \text{ — written 18}$$

$$17 \times 2 - 1 = 33$$

25. **Direction:** Take the given statements as true and decide which of the conclusions logically follow from the statements.

Statements:

(1) Some cows are horses.

(2) Some camels are goats.

(3) All goats are horses.

Conclusions:

I. Some cows are not horses.

II. Some horses are not goats.

III. Some camels are horses.

IV. All horses are camels.

(1) Conclusions I, II and III only follow

(2) Conclusions II, III and IV only follow

(3) Conclusions I and II only follow

(4) Conclusions III and IV only follow

**Answer (1)**

**Sol.**

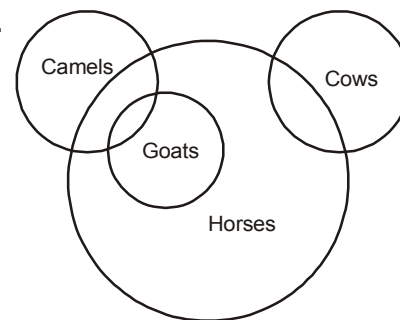

**Questions (26 – 27):**

A high school in Belagavi has 800 students.



(3) 20

(4) 21

**Answer (2)**

**Sol.** Let

= x

= y

= z

**Column 1 :** Sum  $2x + y = 9$  .....(I)

**Row 1 :** Sum  $x = 2y = 12$  .....(II)

$\Rightarrow y = 5$

**Column 2 :** Sum  $2z + y = 23$

Put  $y = 5$

$z = 9$

+ + =  $y + y + z = 5 + 5 + 9 = 19$

34. In the given Matrix find the missing section.

18	21	19	22
20			24
19	22		23
21	24	22	25

(1) 

21	23
	20

(2) 

19	22
	24

(3) 

22	20
	19

(4) 

23	21
	20

**Answer (4)**

**Sol.**  $\left. \begin{matrix} 18 \\ 20 \end{matrix} \right\} +2$   
 $\left. \begin{matrix} 20 \\ 19 \end{matrix} \right\} -1$   
 $\left. \begin{matrix} 19 \\ 21 \end{matrix} \right\} +2$

35. The three pairs of opposite faces of a cube are given

as follows:

**A D**

**B E**

**C F**

Identify the correct figure from the given alternatives, when the cube is unfolded.

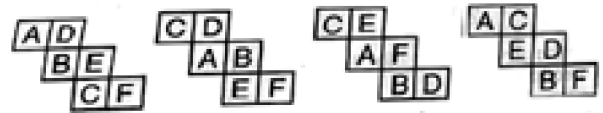

(1)

(2)

(3)

(4)

**Answer (3)**

36. When the problem figure is folded into a cube, which of the following cubes will be formed?

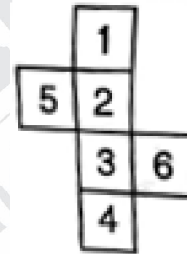

A

B

C

D

(1) A and C only

(2) B and D only

(3) A only

(4) D only

**Answer (1)**

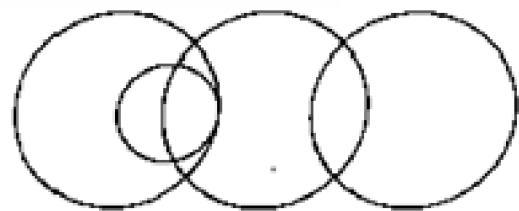

37. Which one of the following relations are represented by the above Venn Diagram?

- (1) Doctors, Engineers, Professors, Businessman
- (2) Professors, Engineers, Doctors, Industrialists
- (3) Lawyers, Doctors, Engineers, Professors
- (4) Doctors, Surgeons, Professors, Engineers

**Answer (4)**

**Questions (38 – 39)**

In a school 90 students play different kinds of games.

Among them,

- (a) 15 play Cricket, Hockey and Football
- (b) 15 play Cricket and Football only
- (c) 10 play Hockey and football only
- (d) Totally 30 play only two kinds of games
- (e) Equal number of students play only on of the games.

38. Find the number of students who play Hockey and Cricket only.

- (1) 5
- (2) 10
- (3) 15
- (4) 20

**Answer (1)**

**Sol.** Total = 90

$$3x + 5 + 10 + 15 + 15 = 90$$

$$3x = 90 - 45$$

$$x = \frac{45}{3} = 15$$

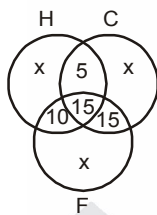

39. Find the number of students who play cricket.

- (1) 40
- (2) 45
- (3) 50
- (4) 55

**Answer (3)**

**Sol.** Number of students who play cricket

$$= x + 5 + 15 + 15$$

$$= 15 + 5 + 15 + 15 = 50$$

40. A square shaped paper is folded as shown and punched. The problem figure shows the paper when unfolded. Which among the alternatives indicates the position of the punch made when it was folded?

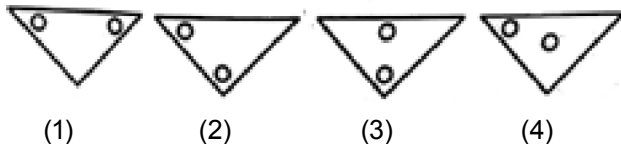
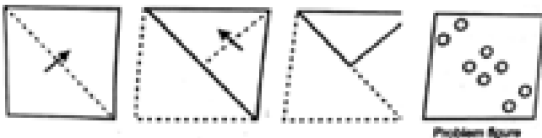

**Answer (2)**

41. Find the missing letters in the given Matrix.

G	C	X	?
C	Y	T	N
X	T	?	I
R	?	I	C

- (1) S, G, N
- (2) R, Q, X
- (3) R, O, N
- (4) Y, P, G

**Answer (3)**

**Sol.**

G	C	X	? <sub>R</sub>
C	Y	T <sub>+1</sub>	N
X	T	? <sub>M</sub>	I
R	? <sub>N</sub>	I	C

Same

42. Find the missing letters in the given Patterns

- (1) A, M
- (2) V, E
- (3) F, Q
- (4) T, P

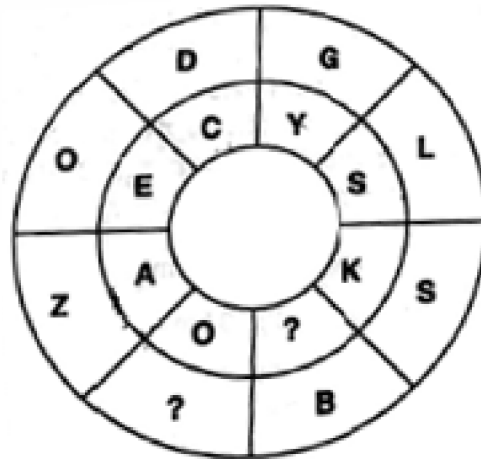

**Answer (1)**

**Sol.**

$$\begin{array}{ccccccc}
 D & \rightarrow & G & \rightarrow & L & \rightarrow & S & \rightarrow & B \\
 & & +2 & & +4 & & +6 & & +8 & & +10 \\
 & & & & & & & & & & \textcircled{M} \\
 C & \rightarrow & Y & \rightarrow & S & \rightarrow & K & \rightarrow & \textcircled{A} \\
 & & -3 & & -5 & & -7 & & -9 & & 
 \end{array}$$

43. A person starts from a place A and moves towards North. He then turns to South east direction and moves. Again he turns towards North and moves for sometime. He then turns to his left and moves. After sometime he turns to South-east and moves. Finally he moves in the west direction and rests at G. Which of the option figures indicates his complete movement?

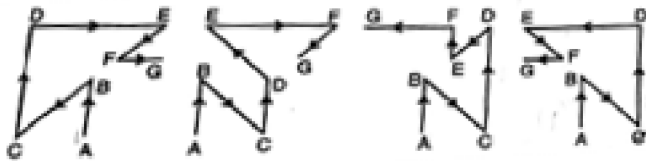

- (1) (2) (3) (4)

**Answer (4)**

44. A motor cyclist moves from a place A to B in East direction. From B he turns to left and moves for 2 km. He then takes a right down and rides for 1.5 km. Again he turns right and moves for 2 km. He then takes a left turn and rides for 2.5 km and stops. If he is distance of 7 km from starting place A, find the distance between A and B.

- (1) 2.5 km (2) 3 km  
(3) 4 km (4) 1 km

**Answer (2)**

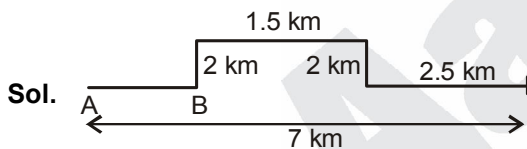

**Questions (45 – 46):**

**Directions:** In the questions below the numbers in the figures are related. Identify their relationship and find the missing numbers in the given figures.

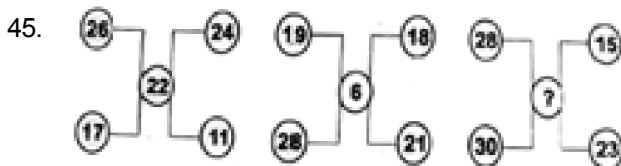

- (1) 20 (2) 18  
(3) 16 (4) 14

**Answer (1)**

**Sol.** Sum of even – sum of odd = central number

$$(26 + 24) - (17 + 11) = 22$$

$$(28 + 18) - (21 + 19) = 6$$

$$(28 + 30) - (15 + 23) = 20$$

46.

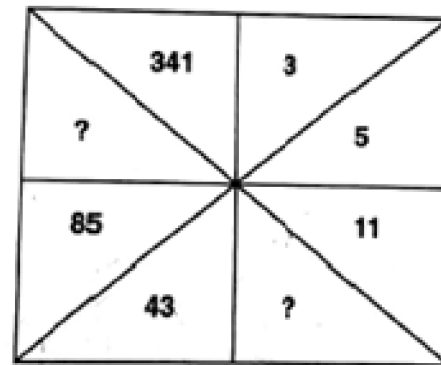

- (1) 18, 151 (2) 18, 169  
(3) 21, 171 (4) 21, 189

**Answer (3)**

**Sol.**  $2 \times 3 - 1 = 5$

$$2 \times 5 + 1 = 11$$

$$2 \times 11 - 1 = 21$$

$$2 \times 21 + 1 = 43$$

$$2 \times 43 - 1 = 85$$

$$2 \times 85 + 1 = 171$$

$$2 \times 171 - 1 = 341$$

**Questions (47 – 48):**

**Directions:** The given problem figure has one or more dots. Observe the dot positions and identify the option figure which is exactly suitable to keep the dots with the same conditions.



(1)

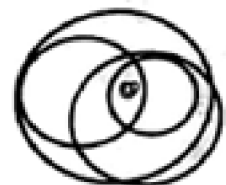

(2)

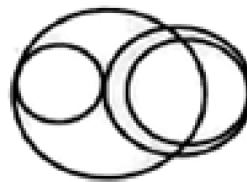

(3)

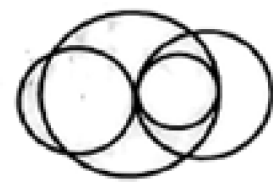

(4)

**Answer (2)**

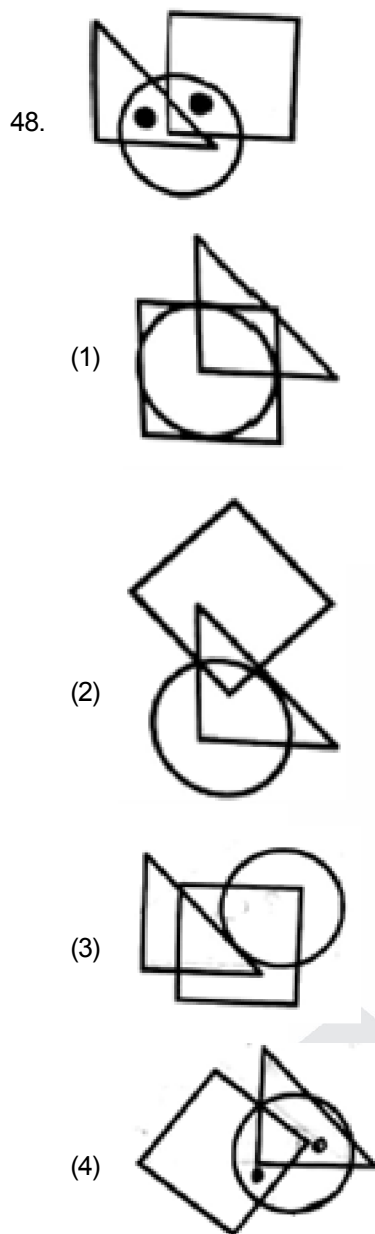

**Answer (4)**

49. The average body weights of 4 men A, B, C and D is 50 kg.

Decide whether the data given in the statements I, II and III are sufficient to find the individual body weights of B and D

I. The weight of A is 65 kg and of C is 45 kg

II. The sum of the weights of B and D is 90 kg

III. D has the least weight compared to A, B and C

(1) Data in I and II are sufficient

(2) Data in II and III are sufficient

(3) Data in I, II and III are sufficient

(4) Data in I, II and III are not sufficient

**Answer (4)**

50. A set of two figures is given as problem figure. Find which one of the option figures is formed, when the upper figure is superimposed on the lower one.

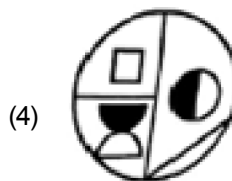
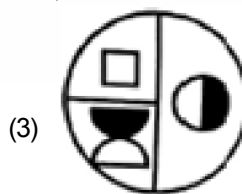
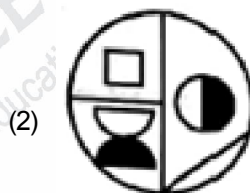

**Answer (1)**



## PART-II : LANGUAGE COMPREHENSIVE TEST

**Questions (1-5) :** Read the following passage and answer the questions given below :

The crowd surged forward through the narrow streets of Paris. There was a clatter of shutters being closed hastily by trembling hands - the citizens of Paris knew that once the fury of the people was excited there was no telling what they might do. They came to an old house which had a workshop on the ground floor. A head popped out of the door to see what it was all about. 'Get him ! Get Thimonier! Smash his devilish machines!' yelled the crowd.

They found the workshop without its owner. M. Thimonier had escaped by the back door. Now the fury of the demonstrators turned against the machines that were standing in the shop, ready to be delivered to buyers. They were systematically broken up and destroyed - dozens of them. Only when the last wheel and spindle had been trampled under foot did the infuriated crowd recover their senses.

'That's the end of, M'sieur Thimonier and his sewing machines', they said to one another and went home satisfied. Perhaps now they would find work; for they were all unemployed tailors and seamstresses who believed that their livelihood was threatened by that new invention.

1. Shutters were being closed hastily because the shopkeepers
  - (1) wanted to attack the crowd
  - (2) feared their shops would be invaded
  - (3) wanted to show their solidarity with the crowd
  - (4) wanted to protect Thimonier

**Answer (2)**

2. The people thought that
  - (1) Their lives were in danger
  - (2) The sewing machines were dangerous
  - (3) Thimonier was depriving them of their livelihood
  - (4) Thimonier was mad

**Answer (3)**

3. The aim of the crowd was to
  - (1) kill Thimonier
  - (2) drive Thimonier away
  - (3) bring discredit to Thimonier
  - (4) scare Thimonier

**Answer (1)**

4. The crowd was protesting against
  - (1) The misdoings of Thimonier
  - (2) The closure of workshops
  - (3) Thimonier keeping the Invention a secret
  - (4) The newly invented sewing machine

**Answer (4)**

5. The passage throws light on
  - (1) What mischief an inventor can do to ordinary people
  - (2) How dangerous an invention can prove to be
  - (3) Why inventions should be avoided altogether
  - (4) How a well-meant invention can be misunderstood

**Answer (4)**

**Questions (6-10):** Read the following passage and answer the questions given below :

It is generally acknowledged that children learn a lot from their parents. It is not so commonly admitted that parents learn a great deal from their children. As adults, it is easy to assume that we are always right, but the laugh was on me one beautiful day.

My daughter Kashmira knew how much I loved flowers. One day when she was nine years, she picked some branches from our neighbour's blossoming fruit tree. Realising she intended to please me, I didn't scold her, but chose a different approach.

"These are lovely, dear, but do you realise that if you had left them on the tree, each of these blossoms would have become a cherry ?"

"No, they wouldn't have", she said firmly. "Oh, yes, they would have each of these blossoms would have grown into a cherry".

"Well okay, mother, if you insist", she finally conceded, "but they were plums last year".

6. What is not commonly acknowledged is that
  - (1) children learn a lot from their parents
  - (2) parents teach their children a great deal
  - (3) parents learn a great deal from their children
  - (4) children learn a great deal in spite of their parents

**Answer (3)**

7. What the daughter picked from the neighbour's garden were some
  - (1) branches
  - (2) flowers
  - (3) branches with fruit
  - (4) branches with blossoms

**Answer (4)**

8. The mother did not scold the daughter because
- (1) she loved flowers
  - (2) she decided to indirectly make her daughter realise her mistake
  - (3) she liked cherry blossoms
  - (4) she did not understand why her daughter had done so

**Answer (2)**

9. "The laugh was on me" means that
- (1) the mother was caught in the wrong
  - (2) the daughter was wrong
  - (3) people laughed at the mother
  - (4) the mother laughed at herself

**Answer (1)**

10. Ultimately the daughter
- (1) proved that she had not picked the branch with the blossom
  - (2) reminded her that she loved flowers
  - (3) reminded her that the branch with blossoms was from a plum tree
  - (4) proved that those blossoms would not yield any fruit

**Answer (3)**

**Questions (11 - 15):** Read the following poem and answer the questions given below:

**A Bird Came Down The Walk**

Emily Dickinson

A Bird, came down the walk  
He did not know I saw  
He bit an Angle worm in halves  
And ate the fellow, raw.  
And then, he drank a Dew  
From a convenient Grass-  
And then hopped sidewise to the wall  
To let a Bettie pass-  
He glanced with rapid eyes,  
That hurried all abroad-  
They looked like frightened Beads, I thought,  
He stirred his velvet Head -

Like one in danger, cautious,  
I offered him a crumb,  
And he unrolled his feathers,  
And rowed him softer Home-  
Than Oars divide the Ocean,  
Too silver for a seam,  
Or Butterflies, off Banks of Noon,  
Leap, plashless as they swim.

11. The poet called the grass 'convenient' because
- (1) the bird could see the beetle in the grass
  - (2) grass is greener on the other side
  - (3) the bird could see the worm in the grass
  - (4) It was easy for the bird to have dew from it

**Answer (4)**

12. The poet describes the eyes of the bird like this
- (1) like frightened beads
  - (2) watery like dew
  - (3) like grass
  - (4) Like butterflies

**Answer (1)**

13. Which of the following is a metaphor?
- (1) A bird came down the walk
  - (2) He stirred his velvet Head
  - (3) He bit an angle worm In halves
  - (4) And then hopped sideways to the wall

**Answer (2)**

14. The antonyms for 'careless', 'cooked', 'courageous' and 'slow' is
- (1) Convenient, raw, frightened, rapid
  - (2) Cautious, hurried, frightened, rapid
  - (3) Cautious, raw, hopped, rapid
  - (4) Cautious, raw, frightened, rapid

**Answer (4)**

15. The bird did not do which of the following?
- (1) Let the beetle pass
  - (2) Unroll his feathers
  - (3) Cook the worm and eat it
  - (4) Glance with rapid eyes

**Answer (3)**



22. The ties that bind a family together are \_\_\_\_\_ that they can hardly withstand any strain.

- (1) twisted
- (2) tenace
- (3) tentative
- (4) tenuous

**Answer (4)**

23. Being \_\_\_\_\_, the judge gave a favourable verdict.

- (1) pugnacious
- (2) sagacious
- (3) malicious
- (4) tenacious

**Answer (2)**

24. A restaurant that presents spick and span look will naturally \_\_\_\_\_ more

- (1) accommodate
- (2) welcome
- (3) avoid
- (4) attract

**Answer (4)**

25. He admired precision in everything, but it never hampered his quick \_\_\_\_\_.

- (1) decision
- (2) dealing
- (3) finalisation
- (4) action

**Answer (1)**

26. One \_\_\_\_\_ and you know who among them is the culprit.

- (1) peep
- (2) sight
- (3) look
- (4) gaze

**Answer (3)**

**Sol.** Look. Look and gaze though mean the same action, they differ. Look is to see something very quickly. Gaze is a intended long look, often used as a synonym for awe. So in the context of the given question look is apt answer. The merit of a person is that he just need a look to find out who is the culprit.

27. Authority \_\_\_\_\_ when it is not supported by the moral purity of its user.

- (1) crumbles
- (2) waits
- (3) empowers
- (4) prevails

**Answer (1)**

**Questions (28 – 37) :** In the following passage there are some numbered blanks. Fill the blanks by selecting the most appropriate word for each blank from the given options:

The recent trend is not towards segregation but (Q. No. 28) \_\_\_\_\_. More and more handicapped children are now being educated (Q. No.29) \_\_\_\_\_ the ordinary schools. The trend towards integration is increasing because of two recent developments. First there has been marked (Q. No. 30) \_\_\_\_\_ in attitude among both the parents of the (Q. No. 31) \_\_\_\_\_ children and the professionals who work with them. The second reason is (Q. No. 32) \_\_\_\_\_ increasing range of aids (Q. No. 33) \_\_\_\_\_ to enable disabled children to be integrated and gain access to the ordinary curriculum. A few years (Q. No. 34) \_\_\_\_\_, aids for disabled in education were either non existent or were bulky and expensive. Many of these new aids are now (Q. No. 35) \_\_\_\_\_ and (Q. No. 36) \_\_\_\_\_. During the past few years, there has been considerable (Q. No. 37) \_\_\_\_\_ in this area.

- 28. (1) unity
- (2) joining
- (3) Integration
- (4) separation

**Answer (3)**

**Sol.** The question could have been,

I look forward to seeing (rather than see) my friend again. Look forward is always followed by gerund (ing form)

- 29. (1) out
- (2) of
- (3) for
- (4) in

**Answer (1)**

- 30. (1) migration
- (2) change
- (3) improvement
- (4) show

**Answer (2)**

- 31. (1) handicapped
- (2) school
- (3) reason
- (4) primary

**Answer (2)**

- 32. (1) rarely
- (2) strongly
- (3) rapidly
- (4) hardly

**Answer (3)**

- 33. (1) available
- (2) exported
- (3) detected
- (4) ago

**Answer (1)**

- 34. (1) hence
- (2) ago
- (3) noticed
- (4) exported

**Answer (2)**



35. (1) big (2) short  
(3) small (4) easy

**Answer (3)**

36. (1) free (2) inexpensive  
(3) easy (4) cost

**Answer (2)**

37. (1) difficulty (2) education  
(3) debate (4) development

**Answer (4)**

**Questions (38-40) :** Choose the appropriate phrasal verbs to complete the sentences.

38. I \_\_\_\_\_ see my friend again.  
(1) look for (2) look out  
(3) look forward to (4) look into

**Answer (3)**

39. I'm afraid; we have \_\_\_\_\_ of apple juice, will an orange juice do ?  
(1) run out (2) run into  
(3) run away (4) run after

**Answer (1)**

40. Your website has helped me a lot to \_\_\_\_\_ the good work.  
(1) keep in (2) keep out  
(3) keep for (4) keep up

**Answer (4)**

**Questions (41 - 43):** Select the meaning of the underlined phrases / idioms.

41. "When pigs fly she'll tidy up her room"  
(1) in the evening  
(2) something that will never happen  
(3) spending a lot of time  
(4) to do it exactly

**Answer (2)**

42. I Let the cat out of the bag about their wedding plans.  
(1) to think about somebody's plan  
(2) to allow the cat to go out of the bag  
(3) agreeing with someone  
(4) to accidentally reveal a secret

**Answer (4)**

43. That girl is so emotional. She'll start crying at the drop of a hat.  
(1) Instantly (2) accidentally  
(3) badly (4) horribly

**Answer (1)**

**Questions (44 – 48) :** Select the most appropriate option to fill in the blanks from the given alternatives.

44. Our rich culture inspires us to take \_\_\_\_\_ in our heritage.  
(1) prided (2) proudly  
(3) pride (4) proud

**Answer (3)**

45. With the changing times, most of the students have become business like; they are \_\_\_\_\_ and want to take only those courses which they find rewarding.  
(1) idealistic (2) pragmatic  
(3) enthusiastic (4) partial

**Answer (2)**

**Sol.** Pragmatic means dealing with things sensibly and realistically based on practical rather than theoretical consideration. While partial means incomplete and carries a negative connotation.

46. Mohan's career has taken some \_\_\_\_\_ twists and turns.  
(1) interesting (2) interactive  
(3) intuitive (4) Incentive

**Answer (1)**

47. She was remarkably \_\_\_\_\_ in singing and dancing.  
(1) conducive (2) fluctuating  
(3) intimidate (4) accomplished

**Answer (4)**

48. Einstein recognised and \_\_\_\_\_ to the scientific world the importance of Bose's discovery  
(1) recommended (2) proclaimed  
(3) proposed (4) acknowledged

**Answer (2)**

**Questions (49 – 50) :** Select the word which means the opposite of the underlined word.

49. Though the murderer was convicted by the District Court, he was \_\_\_\_\_ by the High Court.  
(1) arrested (2) fascinated  
(3) acquitted (4) betrayed

**Answer (3)**

50. They tried to make him confident but he still looked \_\_\_\_\_.  
(1) rejected (2) evident  
(3) provident (4) diffident

**Answer (4)**

**PART-III : SCHOLASTIC APTITUDE TEST (SAT)**

1. When vector  $\vec{A}$  is multiplied by a scalar number-2, then
- (1) The magnitude of vector will be doubled and the direction will be same
  - (2) The magnitude of vector will be doubled and the direction will be opposite.
  - (3) The magnitude and direction of vector remains same
  - (4) The magnitude of vector will be halved and direction is reversed.

**Answer (2)**

**Sol.**  $\vec{A}(-2) = -2\vec{A}$

2. The figure shows velocity-time graph of one dimensional motion of an object. The shaded area represents.

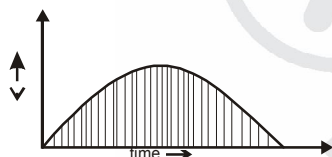

- (1) Momentum
- (2) Acceleration
- (3) Distance travelled
- (4) Speed

**Answer (3)**

**Sol.** Area under V-t graph

= distance travelled by the object

3. Two bodies of masses  $m$  and  $4m$  are moving with equal linear momentum. The ratio of their kinetic energy is.
- (1) 1 : 8
  - (2) 4 : 1
  - (3) 1 : 1
  - (4) 1 : 2

**Answer (2)**

**Sol.**  $P_1^2 = P_2^2 \Rightarrow 2m_1k_1 = 2m_2k_2$

$$\Rightarrow \frac{k_1}{k_2} = \frac{m_2}{m_1} = \frac{4m}{m} = \frac{4}{1}$$

4. In concave mirror the object is placed beyond C. Then the nature and size of the image formed is
- (1) Real, erect and diminished
  - (2) Real, inverted and diminished
  - (3) Virtual, erect and magnified
  - (4) Real, inverted and magnified.

**Answer (2)**

5. **Assertion (A):** The phenomenon of total internal reflection occurs only when the incident light ray travels from denser medium to the rarer medium.

**Reason (R):** When the light ray travels from denser medium to rarer medium the refracted ray bends away from the normal.

**Considering the above:**

- (1) Both A and R are true and R is the correct explanation to A
- (2) Both A and R are true and R is not the correct explanation to A
- (3) Both A and R are false
- (4) A is false and R is true

**Answer (1)**

6. Two bodies of masses 2 kg and 16 kg are separated by a distance of 4m. The gravitational force between these two bodies is ( $G = 6.67 \times 10^{-11} \text{ Nm}^2 \text{ kg}^{-2}$ )

- (1)  $6.67 \times 10^{-11} \text{ N}$
- (2)  $13.34 \times 10^{-11} \text{ N}$
- (3)  $20.01 \times 10^{-11} \text{ N}$
- (4)  $26.68 \times 10^{-11} \text{ N}$

**Answer (2)**

**Sol.**  $F = \frac{Gm_1m_2}{r^2} = \frac{G \times 2 \times 16}{4^2} = 2G$

7. The ascending order of frequency of the given electromagnetic waves is

- (1) IR-rays, Visible-rays, UV-rays, X-rays, Gamma rays
- (2) IR-rays, Visible-rays, X-rays, Gamma rays.
- (3) Gamma rays, X-rays, UV-rays, Visible rays, IT-rays
- (4) Gamma rays, X-rays, Visible rays, UV-rays, IR-rays.

**Answer (1)**

8. To prepare a compound microscope the type of lenses used are

- (1) Eye lens is convex lens of comparatively lower focal length and object lens is convex lens of comparatively higher focal length.
- (2) Eye lens is concave lens of comparatively lower focal length and object lens is concave lens of comparatively higher focal length.
- (3) Eye lens is convex lens of comparatively higher focal length and object lens is convex lens of comparatively lower focal length.
- (4) Eye lens is concave lens of comparatively higher focal length and object lens is concave lens of comparatively lower focal length.

**Answer (3)**



9. **Assertion (A):** Due to variation of pressure speed of sound does not change.

**Reason (R):** The variation of pressure is proportional to variation of density.

**Consider the above:**

- (1) Both A and R are correct and R is the correct explanation to A
- (2) A is correct and R is the wrong explanation to A
- (3) Both A and R are wrong
- (4) A is wrong and R is correct

**Answer (3)**

**Sol.** Assertion (A)

$$v = \sqrt{\frac{\gamma P}{\rho}} \quad v \propto \sqrt{P} \text{ if } \rho = \text{constant}$$

Reason (R)

$$P = \frac{\rho RT}{M} \quad P \propto \rho, \text{ If } T = \text{constant}$$

Since it is not mentioned, whether  $\rho$  and  $T$  are constant or not, both assertion and reason are wrong.

10. When 1 mg of matter is converted into energy, the amount of energy released is

- (1) 90 J
- (2)  $9 \times 10^5 \text{ J}$
- (3)  $9 \times 10^3 \text{ J}$
- (4)  $9 \times 10^{10} \text{ J}$

**Answer (4)**

**Sol.**  $E = mc^2 = (1 \times 10^{-6} \text{ kg})(3 \times 10^8 \text{ m/s})^2 = 9 \times 10^{10} \text{ J}$

11. If the temperature of sun is doubled, the energy received by the earth increases by.

- (1) 2 times
- (2) 8 times
- (3) 16 times
- (4) 32 times

**Answer (3)**

**Sol.**  $E \propto T^4$

12. The circuit diagram which shows the conversion of both the half cycles of AC into DC is ( $D_1$  and  $D_2$  are diodes,  $R_L \rightarrow$  load resistance)

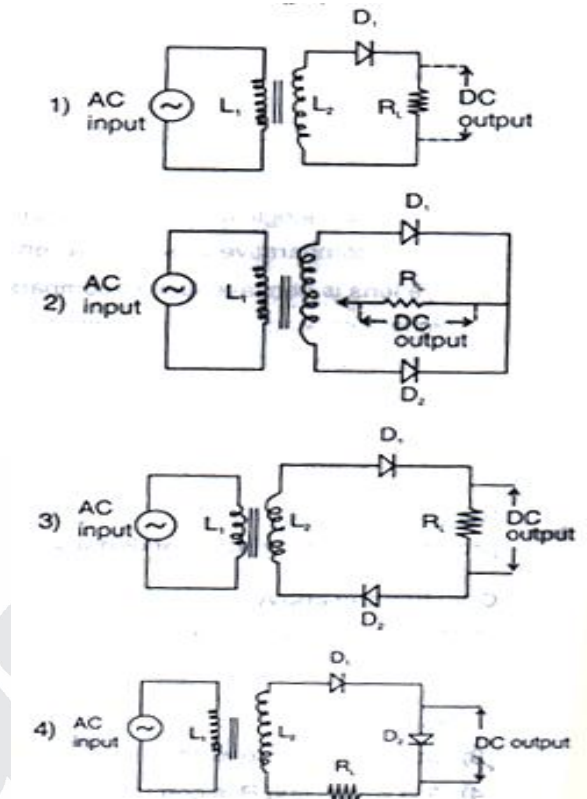

**Answer (2)**

13. In the given circuit the effective resistance between A and B is

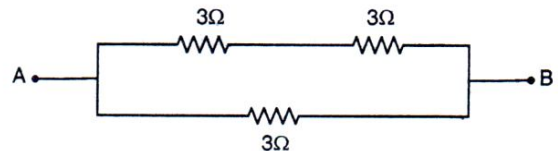

- (1)  $9\Omega$
- (2)  $6\Omega$
- (3)  $1.5\Omega$
- (4)  $2\Omega$

**Answer (4)**

**Sol.**  $R = \frac{6 \times 3}{6 + 3} = 2\Omega$

14. **Assertion (A):** 'Ge is a better semiconductor than 'Si' but 'Si' is widely used than 'Ge'

**Reason (R):** Structure of 'Si' crystals cannot be damaged as easy as that of 'Ge' at higher temperature.

- (1) A and R are false
- (2) A is false and R is true
- (3) A and R are true
- (4) A is true and R is false

**Answer (3)**

15. The atoms having the bigger size among each of the following pair are
- Mg (At.No.12) or Cl (At.No.17)
  - Na (At.No.11) or K (At.No.19)
- (1) Mg and K                      (2) Mg and Na  
(3) Cl and Na                      (4) Cl and K

**Answer (1)**

16. The highly significant isomers among the following compounds are
- Methane
  - Propane
  - Butane
  - Hexane
- (1) A and B                      (2) A and D  
(3) B and C                      (4) C and D

**Answer (4)**

17. When the universal indicator solution is added to three unknown colourless solutions P,Q and R they change to Blue, Violet and Orange colours respectively. The increasing order of the pH values of these solutions are
- (1)  $Q > R > P$                       (2)  $R > Q > P$   
(3)  $Q > P > R$                       (4)  $P > Q > R$

**Answer (3)**

18. Only selected steps of silicon preparation are jumbled below after inserting few irrelevant steps. The option with correct order of only right steps is
- Heat the fire clay crucible
  - Mixture of silica and magnesium powders are taken in the fire clay crucible.
  - Water is added to the crucible
  - Crystal form of silicon is obtained
  - Hydrofluoric acid is used
  - Amorphous form of silicon is obtained
- (1) a b d e                      (2) b c e f  
(3) b a d e                      (4) b a e f

**Answer (4)**

19. An element reacts with water to form a solution which turns phenolphthalein solution pink is
- (1) S                                  (2) Ca  
(3) C                                  (4) Ag

**Answer (2)**

20. The equation  $Mg_{(s)} + CuO_{(s)} \rightarrow MgO_{(s)} + Cu_{(s)}$  represents
- decomposition reaction
  - displacement reaction
  - combination reaction
  - double displacement reaction
  - redox reaction
- (1) a and b                      (2) c and d  
(3) b and e                      (4) d and e

**Answer (3)**

21. Select the correct option that confirms the chemicals taken in the test tubes A and B on the basis of the following statements related to its properties.

**Statement (A):** Chemicals of 'A' gives burning taste and 'B' has the smell of Vinegar.

**Statement (B):** Chemicals of 'A' turns blue litmus paper to red and 'B' gives brisk effervescence with sodium hydrogen carbonate.

- A has ethanol and B does not ethanoic acid
- A does not have ethanol and B has ethanoic acid
- A has ethanol and B has ethanoic acid
- A has ethanoic acid and B has ethanol

**Answer (2)**

22. The solution to be mixed with lead nitrate to obtain yellow precipitate is
- Potassium iodide
  - Potassium sulphide
  - Potassium nitride
  - Potassium chloride

**Answer (1)**

**Sol.** [Hint :  $Pb(NO_3)_2 + KI \rightarrow PbI_2 + 2KNO_3$ ]  
Yellow

23. An element 'X' forms two oxides 'XO' and 'XO<sub>2</sub>'. The oxide 'XO' is neutral but 'XO<sub>2</sub>' is acidic in nature. The element 'X' is
- Sulphur                      (2) Calcium  
(3) Hydrogen                      (4) Carbon

**Answer (4)**

**Sol.** Hint: XO    XO<sub>2</sub>  
                  CO    CO<sub>2</sub>  
                  Neutral Acidic

24. The type of the bond in the compound XY where X and Y belongs to 1st and 17th groups of the periodic table respectively is

- (1) Hydrogen bond                      (2) Ionic bond  
 (3) Polar bond                            (4) Covalent bond

**Answer (2)**

**Sol.** Hint: Ionic bond

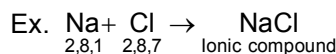

25. The organic compounds, whose both melting and boiling points are either positive or negative values only

- a. Methane                                b. Trichloromethane  
 c. Ethanol                                 d. Ethanoic acid  
 (1) a and b                                (2) b and c  
 (3) a and d                                (4) c and d

**Answer (3)**

26. The characteristics and its trends of certain range of elements in a periodic table are matched. The correct option is

- a. Electronegative character from 'Na' to 'Al'                      I. Decreases  
 b. Non metallic character from F to I                      II. Remains constant  
 c. Number of valence electrons from Be to Ca                      III. Increases  
 (1) a-II, b-I, c-III                            (2) a-III, b-II, c-I  
 (3) a-II, b-III, c-I                            (4) a-III, b-I, c-II

**Answer (4)**

27. Match Column-I with Column-II and identify the correct answer

- | Column-I                   | Column-II                 |
|----------------------------|---------------------------|
| A. Virus                   | i. Ring worm              |
| B. Bacteria                | ii. Filariasis            |
| C. Protozoa                | iii. Tetanus              |
| D. Nematoda                | iv. Sleeping sickness     |
|                            | v. Polio                  |
| (1) A-ii, B-v, C-i, D-iii  | (2) A-iii, B-iv, C-v, D-i |
| (3) A-v, B-iii, C-iv, D-ii | (4) A-ii, B-i, C-v, D-iii |

**Answer (3)**

**Sol.** Virus-Polio; Bacteria-Tetanus; Protozoa-Sleeping sickness; Nematoda-Filariasis

28. If the sebaceous glands are not functioning then

- (1) the body will not be able to regulate the body temperature  
 (2) the skin will turn darker with more melanin  
 (3) the hair will fail to grow  
 (4) the skin will turn dry and rough

**Answer (4)**

**Sol.** Sebaceous glands are known to produce oil which keep skin moisturised.

29. The joint between humerus and ulna that moves in one plane only

- (1) Gliding joint  
 (2) Hinge joint  
 (3) Pivot joint  
 (4) Ball and socket joint

**Answer (2)**

**Sol.** Hinge joints allows movement only in one plane. End of one bone is deep convex in shape and the other end of bone is deep concave, which forms the joint.

30. Read the following statements and select the correct option

- A. It is a colourless, highly acidic liquid  
 B. It contains an enzyme called pepsin  
 C. It kills any germs which may have entered along with the blood  
 D. It converts protein into peptides  
 (1) Pancreatic juice                      (2) Bile juice  
 (3) Gastric juice                         (4) Saliva

**Answer (3)**

31. **Assertion (A):** Colour blindness is more common in males than in females.

**Reason (R):** Colour blindness defect is due to dominant genes which occur in the 'Y' chromosomes.

Select the correct option from the given alternatives.

- (1) 'A' is true and 'R' is false  
 (2) 'A' is false and 'R' is true  
 (3) Both 'A' and 'R' are true and 'R' explains 'A'  
 (4) Both 'A' and 'R' are true but 'R' does not explain 'A'

**Answer (1)**

**Sol.** Colors blindness is X linked recessive disorder which expresses itself only in homozygous recessive condition. Hence females behave as carriers without getting affected by the defected X chromosome. As males have one copy of X chromosome they express the condition.

32. Study the labelled diagram below and select the correct option

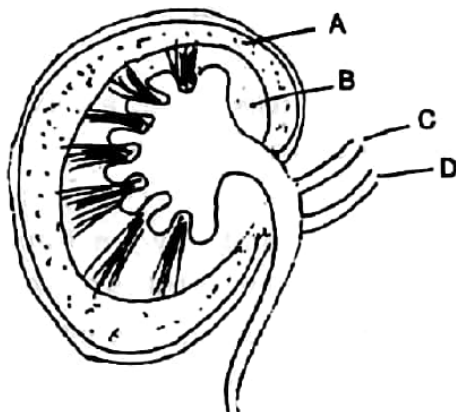

- |                 |                 |
|-----------------|-----------------|
| (1) A. Medulla  | B. Cortex       |
| C. Renal artery | D. Renal vein   |
| (2) A. Cortex   | B. Medulla      |
| C. Renal vein   | D. Renal artery |
| (3) A. Cortex   | B. Medulla      |
| C. Renal artery | D. Renal vein   |
| (4) A. Medulla  | B. Cortex       |
| C. Renal vein   | D. Renal artery |

**Answer (3)**

33. Read the following statements and select the correct option.

- A. Oxytocin causes constriction of uterus muscles during child birth  
 B. Insulin stimulates deposition of extra glucose of the blood as glycogen in liver and muscles
- (1) 'A' is false 'B' is true  
 (2) 'A' is true 'B' is false  
 (3) Both 'A' and 'B' are true  
 (4) Both 'A' and 'B' are false

**Answer (3)**

**Sol.** Oxytocin is also called as child birth hormone as it brings about contraction of smooth muscles of uterus wall.

Insulin reduces blood sugar level by enhancing its uptake by cells and by glycogenesis in liver and muscles.

34. A plant that shows viviparous germination
- (1) Green pea                      (2) Rhizophora  
 (3) Bean                              (4) Green gram

**Answer (2)**

**Sol.** Rhizophora also called as mangrove plant seeds germinate while being attached to parent plant called viviparous germination.

35. Identify the correct statements about photosynthesis
- A. Mesophyll cells in a leaf are the principal centre of photosynthesis  
 B. Splitting of water ( $H_2O$ ) molecules into hydrogen and oxygen ions in the presence of light is called polymerisation  
 C. Conversion of glucose into starch is called photolysis  
 D. The electrons are used in converting ADP into energy rich compound ATP by adding one phosphate group  $P_i$  is called photophosphorylation

- (1) 'A' and 'D' only              (2) 'A' and 'C' only  
 (3) 'B' and 'C' only              (4) 'C' and 'D' only

**Answer (1)**

**Sol.** Splitting of  $H_2O$  molecule in the presence of light energy is called photolysis.

Conversion of glucose into starch is called polymerisation.

36. If the common salt is sprinkled on lawn grass, it is killed at the spot. This is due to
- (1) Plasmolysis                      (2) Adhesion  
 (3) Capillary action              (4) Imbibition

**Answer (1)**

**Sol.** Sprinkling salt on grass creates hypertonic condition which causes plasmolysis in plant cells. Prolonged plasmolysis causes death of grasses.

37. Read the following statements and select the correct option.
- A. Auxins help to prevent fruit and leaf drop at early stages  
 B. Abscisic acid promotes seed germination
- (1) 'A' is false and 'B' is true  
 (2) 'A' is true and 'B' is false  
 (3) Both 'A' and 'B' are true  
 (4) Both 'A' and 'B' are false

**Answer (2)**

**Sol.** Abscisic acid inhibits seed germination.



38. Cretinism and myxedema are due to
- (1) Hyper secretion of growth hormone
  - (2) Hypo secretion of growth hormone
  - (3) Hyper secretion of thyroxin
  - (4) Hypo secretion of thyroxin

**Answer (4)**

**Sol.** Cretinism-reduces growth and causes mental retardation in children due to reduced secretion of thyroxine in adults.

Myxedema-Swelling of body tissues due to fluid retention caused by reduced secretion of thyroxine.

39. Rahul's friends are suffering from some diseases. Ritika is suffering from rickets, Satish has haemophilia and Soumya has  $H_1N_1$ . Then who can communicate disease to Rahul?
- (1) Ritika and Soumya only
  - (2) Satish and Soumya only
  - (3) Soumya only
  - (4) Ritika only

**Answer (3)**

**Sol.** Soumya has  $H_1N_1$  which is caused by virus and is a communicable disease.

Rickets and hemophilia are vitamin D deficiency and genetic disorder respectively. Which cannot be transmitted.

40. Refer to the given Venn diagram below and select the correct option regarding 'X', 'Y' and 'Z'.

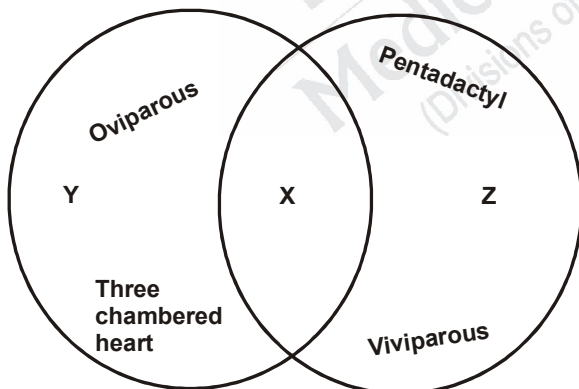

- (1) 'Y' can be lizard, 'Z' can be tiger and there is no such organism as 'X'
- (2) 'X' can be bat and 'Z' can be ostrich
- (3) 'Y' can be snake and 'Z' can be emu
- (4) There is no such organism as 'Z'

**Answer (1)**

**Sol.** Y-Lizard-Reptiles have 3 chamberd heart and are oviparous

Z-Tiger-Pentadactyl *i.e.*, 5 digits and viviparous

41. Bhagath Singh, Jathindas, Batukeshwar and others founded a Revolutionary Association called
- (1) Hindusthan Army for Independence
  - (2) Hindusthan Socialist Republic Army
  - (3) Hindusthan Socialist Revolutionary Army
  - (4) Hindusthan Kissan Movement Sabha

**Answer (2)**

42. Choose the group of correct statements related to II Carnatic War
- a. Battle between Nasir Jung and Muzaffar Jung for the throne of Hyderabad Nizam.
  - b. Britishers helped Anwaruddin.
  - c. French helped Chandra Saheb under the leadership of Duplex.
  - d. Britishers defeated Nasir Jung in a battle
- (1) a, b and c
  - (2) a and d
  - (3) a, b and d
  - (4) a, c and d

**Answer (1)**

43. The idea of Indian National Army (INA) was Conceived by
- (1) Subhaschandra Bose
  - (2) Ross Behari Bose
  - (3) Mohan Singh
  - (4) Aravind Ghosh

**Answer (3)**

44. Choose the correct of the incidents of Indian freedom movement in a chronological order:
- a. Poona Agreement
  - b. Direct Action Day
  - c. August Offer
  - d. Establishment of Forward Block Party
- (1) a, d, c, b
  - (2) b, a, d, c
  - (3) a, d, b, c
  - (4) d, a, b, c

**Answer (1)**

45. Choose the correct group of areas in which Britishers introduced the Ryotwari system.

- a. Madras                                      b. Bengal  
c. Sindh                                         d. Assam  
(1) a and b                                      (2) a, b and c  
(3) b, c and d                                   (4) a, c and d

**Answer (4)**

46. Identify the correct statements related to French Revolution

- a. Priests and rich class people are exempted from paying taxes and led a luxurious life.  
b. Agricultural and industrial developments were stumbled.  
c. Count Cavour made a secret pact with France.  
d. Louis XVI of Bourbon dynasty led a luxurious and extravagant life.  
(1) a, b and c                                      (2) a, c and d  
(3) b, c and d                                      (4) a, b and d

**Answer (4)**

47. Choose the group of nations which belong to Triple Alliance during First World War

- a. Germany                                      b. Russia  
c. Austria                                         d. Italy  
(1) a and b                                      (2) a, b and c  
(3) a, c and d                                      (4) a, b, c and d

**Answer (3)**

48. The principle based on which the insurer is liable only for those losses which have been insured against is

- (1) Principle of indemnity  
(2) Principle of contributions  
(3) Principle of loss minimization  
(4) Principle of proximate cause

**Answer (4)**

49. Match the items in List-A Entrepreneurs with List-B Entrepreneurship

- |                        |                       |
|------------------------|-----------------------|
| a. Naresh Goyal        | I. Infosys            |
| b. Kiran Mazumdar Shah | II. Reliance          |
| c. Narayan Murthy      | III. Balaji Telefilms |
| d. Dhirubai Ambani     | IV. Biocan            |
|                        | V. Jet Airways        |

- |     |     |     |    |    |
|-----|-----|-----|----|----|
|     | a   | b   | c  | d  |
| (1) | V   | IV  | I  | II |
| (2) | IV  | V   | I  | II |
| (3) | III | V   | I  | II |
| (4) | V   | III | IV | II |

**Answer (1)**

50. Metternich remarked "When France Sneezes, the rest of Europe catches cold". Identify the most appropriate justification for this statement

- (1) French revolution sparked nationalism  
(2) French revolution inspired world nations  
(3) The development in France ignited uprising in Belgium and breaking away from UK  
(4) France became the leader of Europe

**Answer (3)**

51. The Kannada speaking region which came under the rule of Madras province in 19th century is

- (1) Raichur                                      (2) Bellari  
(3) Bijapura                                      (4) Gulbarga

**Answer (2)**

52. Match personals in List-A with appropriate positions in List-B

- | List-A                     | List-B                             |
|----------------------------|------------------------------------|
| a. Shaikh Abdulla          | I. State Reorganisation Commission |
| b. Fazal Ali               | II. Chief of Razakars              |
| c. Sardar Vallabhbai Patel | III. King of Jammu and Kashmir     |
| d. Qasim Razvi             | IV. First Home Minister of India   |
| e. Raja Harisingh          | V. Founder of National Conference  |

- |     |   |   |    |     |     |
|-----|---|---|----|-----|-----|
|     | a | b | c  | d   | e   |
| (1) | I | V | IV | III | II  |
| (2) | V | I | IV | III | II  |
| (3) | V | I | II | IV  | III |
| (4) | V | I | IV | II  | III |

**Answer (4)**

53. Identify the group of Financial Institutions with gives loan to small scale industries.

- (1) IDBI, IFCI, SFC, SIDBI  
(2) RBI, NABARD, IFCI, IDBI  
(3) NABARD, IDBI, RBI, SFC  
(4) SIDBI, RBI, NABARD, IDBI

**Answer (1)**



54. Identify the correct group of Nationalised Banks
- (1) Canara Bank, State Bank of India, Vijaya Bank, Dena Bank, IDBI Bank
  - (2) IDBI Bank, ICICI Bank, Karnataka Bank, Dena Bank, Canara Bank
  - (3) IDBI Bank, Vijaya Bank, ICICI Bank, Karnataka Bank, Canara Bank
  - (4) Vijaya Bank, Canara Bank, HDFC Bank, ICICI Bank, Dena Bank

**Answer (1)**

55. The correct statement that is related to French East India Company is that it was,
- (1) Private Company
  - (2) Private Company controlled by the French Government
  - (3) Officially a State owned company
  - (4) Controlled by the French Merchant

**Answer (3)**

56. The correct decreasing order of the neighbouring countries based on the length of the border that India shares is
- (1) China, Bangladesh, Nepal, Pakistan
  - (2) Bangladesh, Pakistan, China, Nepal
  - (3) China, Bangladesh, Pakistan, Nepal
  - (4) Bangladesh, China, Pakistan, Nepal

**Answer (4)**

57. Choose the right arrangement of mountain ranges of India from South to North.
- (1) Western Ghats, Vindhya Ranges, Satpura Hills, Aravali Hills
  - (2) Western Ghats, Aravali Hills, Satpura Hills, Vindhya Ranges
  - (3) Western Ghats, Satpura Hills, Vindhya Ranges, Aravali Hills
  - (4) Vindhya Ranges, Western Ghats, Aravali Hills, Satpura Hills

**Answer (3)**

58. Match Column 'A' with Column 'B' and choose correct answer.

Column-A	Column-B
a. Kaziranga National Park	I. Assam
b. Sundarbans	II. West Bengal
c. Gir National park	III. Gujarat
d. Tandova National Park	IV. Maharashtra

- |     | a  | b   | c   | d   |
|-----|----|-----|-----|-----|
| (1) | I  | II  | III | IV  |
| (2) | I  | III | II  | IV  |
| (3) | I  | IV  | III | II  |
| (4) | IV | II  | I   | III |

**Answer (1)**

59. **Assertion (A):** Increase in population, urbanisation, Industrialisation lead to the increased use of fossil fuels.

**Reason (R):** Over use of conventional energy resources has resulted in the phenomenon of green house effect.

Select the correct option from the given alternatives.

- (1) A is true, R is false
- (2) A is false, R is true
- (3) Both A and R are true, but R is not correct explanation of A
- (4) Both A and R are true and R is the correct explanation of A

**Answer (4)**

60. Choose the group of statements, which are correct with respect to "Golden Quadrilateral and Corridor Project".
- a. This project covers National Highways with the length of 15,000 kms.
  - b. The project was started in the year 2001
  - c. Total cost of the proposed project was Rs. 54,000 crores
  - d. This is the largest project taken up and no country in the world has taken up such project
- (1) a, b and c
  - (2) b, c and d
  - (3) a, b, c and d
  - (4) a, c and d

**Answer (4)**

61. **Assertion (A):** Majority of paper industries are found in West Bengal.

**Reason (R):** News print paper is being imported from Norway, Sweden, Canada and the U.S.A.

Select correct option from the given alternatives.

- (1) A true, R false
- (2) A false, R true
- (3) Both A and R are true, but 'R' is not the correct explanation of 'A'
- (4) Both 'A' and 'R' are true, but 'R' is the correct explanation of 'A'

**Answer (3)**

62. The total population of an area divided by its geographical area gives
- (1) Population index
  - (2) Distribution of population
  - (3) Population Density
  - (4) Population growth rate

**Answer (3)**

63. Match Column 'A' with Column 'B' and choose correct answer.

Column-A	Column-B
a. Rawat Bata	I. Thermal Electricity
b. Barauni	II. Wind Energy
c. Nagarcoil	III. Atomic Energy
d. Baramar	IV. Solar Energy

	a	b	c	d
(1)	III	I	II	IV
(2)	I	III	II	IV
(3)	III	I	IV	II
(4)	IV	III	II	I

**Answer (1)**

64. Section 25 of Indian Constitution provides following right to Citizens of India
- (1) Guarantees educational facilities to all
  - (2) Guarantees reservation in political field to scheduled castes and tribes
  - (3) Guarantees reservation in the employment sector to scheduled castes and tribes
  - (4) Guarantees free entry to all people to social and religious places

**Answer (4)**

65. The main cause for Land degradation in Punjab, Haryana and Western part of Uttar Pradesh
- (1) Intensive Agriculture
  - (2) Over Irrigation
  - (3) Deforestation
  - (4) Mining

**Answer (2)**

66. Match Column 'A' with Column 'B' and choose correct answer.

Column-A	Column-B
a. group of people pelting stones	I. Movement
b. people assembled near a theatre to buy tickets	II. Campaign

- c. A group protesting against a project in a peaceful way
- d. A group of people involved in bringing awareness

	a	b	c	d
(1)	III	IV	I	II
(2)	I	II	III	IV
(3)	III	I	IV	II
(4)	IV	II	I	III

**Answer (1)**

67. Choose the group of correct answer with respect to the statements about South West Monsoon
- a. Trade winds transform as South West Monsoon after they cross Equator
  - b. These enter India in two branches
  - c. Most of the country's region receive rain during South West Monsoon except Tamil Nadu
  - d. The western region of the Western Ghats is called rain-shadow region

- (1) b and c only
- (2) a, b and c
- (3) b, c and d
- (4) a, b and d

**Answer (2)**

68. Match the nations and the respective names of cyclones and choose correct answer.

A	B
a. India	I. Thane
b. Bangladesh	II. Giri
c. Myanmar	III. Mujan
d. Oman	IV. Jal

	a	b	c	d
(1)	IV	II	I	III
(2)	II	III	I	IV
(3)	II	III	IV	I
(4)	IV	III	II	I

**Answer (1)**

69. Match the following and choose correct answer.

<b>Animals/Birds</b>	<b>Category of Existence species</b>
a. Indian Rhino	I. Rare species
b. Hornbill	II. Extinct species
c. Asiatic cheetah	III. Vulnerable species
d. Ganges Dolphin	IV. Endangered species

	a	b	c	d
(1)	IV	II	I	III
(2)	IV	I	II	III
(3)	III	II	IV	I
(4)	III	II	I	IV

**Answer (2)**

70. Arrange the area covered by types of soil in India, in increasing order

- (1) Laterite soil, Red soil, Black soil, Alluvial soil
- (2) Laterite soil, Black soil, Red soil, Alluvial Soil
- (3) Alluvial soil, Black soil, Red soil, Laterite soil
- (4) Alluvial soil, Red soil, Black soil, Laterite soil.

**Answer (1)**

71. Match list 01 of Heads/Ministers of Executive of Indian Government with List 02 of their "functions" and select the correct answer using the codes given below.

**List-01**  
**(Heads of Executive of Indian Government)**

- A. President
- B. Vice President
- C. Prime Minister
- D. Finance Minister

**List-02**  
**(Functions)**

- I. Chairperson of the NITI Ayoga
- II. Appointment of Chief Minister to States
- III. Appointment of Governors of State
- IV. Presentation of Union Budget
- V. Act as Ex-Officio Chairperson of Rajya Sabha

**Codes:**

- |           |       |       |      |
|-----------|-------|-------|------|
| (1) A-i,  | B-v   | C-iv  | D-ii |
| (2) A-ii  | B-iii | C-iv  | D-i  |
| (3) A-iii | B-v   | C-i   | D-iv |
| (4) A-iv  | B-ii  | C-iii | D-i  |

**Answer (3)**

72. List-A is the list of Regional Parties, List-B is their existence in the State and List -C is their symbol.

<b>List-A</b> <b>(Regional Parties)</b>	<b>List-B</b> <b>(State their existence)</b>	<b>List-C</b> <b>(Symbol)</b>
A. Shivassena	E. Tamil nadu	I. Arrow
B. AIADMK	F. Maharashtra	J. Two leaves
C. Peoples Democratic Party	G. Bihar	K. Ink pot and pen
D. JD (U)	H. Jammu & Kashmir	L. Bow and arrow

The correctly matched set related to the above table is

- (1) AFL, BEJ, CHK, DGI
- (2) AFK, BGI, CEL, DHJ
- (3) AEL, BGK, CHJ, DFL
- (4) AHI, BGJ, CFL, DEK

**Answer (1)**

73. First Indian Women President is coded as (P), Prime Minister as (Q), Governor as (R) and Chief Minister as (S) and their names are given below.

- a. Indira Gandhi
- b. Suchetha Kripalani
- c. Prathiba Patil
- d. Sarojini Naidu

Which one of the following choices represents PQRS order?

- (1) c a b d
- (2) d c b a
- (3) d a b c
- (4) c a d b

**Answer (4)**

74. Regional Co-operation Organisations of different nations are given below.

- I. SAARC
- II. ASEAN
- III. European Union
- IV. African Unity

Identify the correct choice of these organisations in the chronological order of establishment.

- (1) I III IV II
- (2) IV II I III
- (3) III I II IV
- (4) II IV III I

**Answer (2)**

75. Read the following statements and select the correct option.

**Assertion (A):** The Governor of a State cannot be dismissed by the Chief Minister.

**Reason (R):** The Governor of a State is not elected.

- (1) Both 'A' and 'R' are true and 'R' is the correct explanation of 'A'
- (2) Both 'A' and 'R' are true and 'R' is not the correct explanation of 'A'
- (3) 'A' is true but 'R' is false
- (4) 'R' is true but 'A' is false

**Answer (2)**

76. Which of the following statement/statements about Anti Defection Law is/are correct?

- A. The Constitution Act of 1985 is popularly known as the Anti Defection Law.
- B. Independently elected member of Parliament or a State Legislature will not be disqualified if he/she join any political party after elections.

**Choices:**

- (1) Only A is correct
- (2) Only B is correct
- (3) Both A and B are correct
- (4) Both A and B are incorrect

**Answer (1)**

77. Calculate the Male Literacy Rate from given data and choose the correct answer from the given choices.

Gender	Total Persons	Literate persons
Male	1350	981
Female	785	435
Total	2135	1416

- (1) 78.5%
- (2) 66.3%
- (3) 55.4%
- (4) 72.6%

**Answer (4)**

78. The following are the major changes that occurred in agriculture as a result of Green Revolution in India.

- a. Use of high yield variety seeds in wheat grains only
- b. The poor and marginal small farmers avail the benefits of improved technology
- c. Construction of granaries, cold storages warehouses to store the surplus produce
- d. The improved technology of Green Revolution was restricted and practices in northern states of India i.e., Punjab, Haryana, Rajasthan States.

Which of the above signifies post harvest technology of Green Revolution?

- (1) a and b
- (2) c and d
- (2) b and c
- (3) d and a

**Answer (2)**

79. Whom would you consider as unemployed related to the following situations?

- A. A farmer in farm produces 100 kg paddy in one acre of land during every season. In addition one year his adult son Raju joined him in farming. But output remained the same.
  - B. Raghu has income by his huge property to lead comfort life. So he does not work.
- (1) Raju is unemployed
  - (2) Raghu is unemployed
  - (3) Both Raju and Raghu are unemployed
  - (4) Both Raju and Raghu are not unemployed

**Answer (3)**

80. Indicators of development are given below.

- a. National Income
- b. Per capita Income
- c. Life expectancy
- d. Educational Achievement
- e. Rate of women's job participation
- f. Standard of living

Which of the above indicators are measured in Human Development Index?

- (1) a, b, c
- (2) c, d, f
- (3) a, b, e
- (4) d, e, f

**Answer (2)**

81. The area of two concentric circles are  $1386 \text{ cm}^2$  and  $962.5 \text{ cm}^2$ . The width of the ring is

- (1) 4.2 cm
- (2) 3.8 cm
- (3) 3.5 cm
- (4) 2.8 cm

**Answer (3)**

**Sol.**

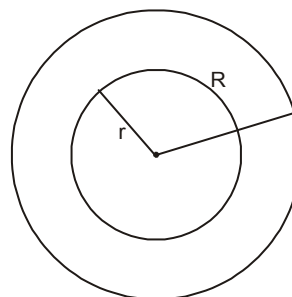

$$\pi R^2 = 1386$$

$$\Rightarrow \boxed{R = 21}$$

$$\pi r^2 = 962.5$$

$$\boxed{r = 17.5}$$

$$\boxed{w = R - r = 21 - 17.5 = 3.5\text{cm}}$$

82. On increasing the radius of the base and height of a cone each by 20%, then the percentage increase in the volume will be

- (1) 20%                                      (2) 40.8%  
 (3) 60%                                      (4) 72.8%

**Answer (4)**

**Sol.** Option 4

$$\text{Volume of cone, } V = \frac{1}{3}\pi r^2 h$$

$$\begin{aligned} \text{New volume of cone} &= \frac{1}{3}\pi \left(\frac{6}{5}r\right)^2 \left(\frac{6h}{5}\right) \\ &= \frac{1}{3}\pi \left(\frac{36}{25}r^2\right) \left(\frac{6h}{5}\right) \\ &= \left(\frac{216}{125}\right) \frac{1}{3}\pi r^2 h \\ &= (1.728) \left(\frac{1}{3}\pi r^2 h\right) \end{aligned}$$

$$\begin{aligned} \% \text{ Increase in Volume} &= \frac{\text{New vol} - \text{old vol}}{\text{old vol}} \\ &= \frac{1.728V - V}{V} \times 100 = 72.8\% \end{aligned}$$

83. If -4 is a root of the quadratic equation  $x^2 + px - 4 = 0$  and the equation  $x^2 + px + m = 0$  has equal roots, then the value of "m" is

- (1) -4                                      (2)  $\frac{25}{4}$   
 (3) +4                                      (4)  $\frac{-25}{4}$

**Answer (Given options are wrong)**

**Sol.** Given options are wrong

$$\text{'-4' is a root of equation } x^2 + px - 4 = 0$$

$$\Rightarrow 16 - 4p - 4 = 0$$

$$\Rightarrow 4p = 12$$

$$\boxed{p = 3}$$

$$x^2 + 3x + m = 0 \text{ has equal roots}$$

$$\Rightarrow b^2 - 4ac = 0$$

$$9 - 4m = 0$$

$$\boxed{m = 9/4}$$

84. Statement-I: If  $\sqrt{5 + \sqrt{24}} = \sqrt{x} + \sqrt{y}$  then  $x + y = 5$  and  $xy = 24$ .

Statement-II: The square root of  $(5 - \sqrt{24})$  is  $(\sqrt{3} - \sqrt{2})$ .

- (1) Both statement-I and II are wrong  
 (2) Statement-I is wrong, but statement-II is right  
 (3) Both statement-I and II are right  
 (4) Statement-I is right, but statement-II is wrong

**Answer (2)**

$$\text{Sol. } \sqrt{5 + \sqrt{24}} = \sqrt{x} + \sqrt{y}$$

$$\Rightarrow \sqrt{5 + 2\sqrt{6}} = \sqrt{x} + \sqrt{y}$$

$$\Rightarrow \sqrt{3} + \sqrt{2} = \sqrt{x} + \sqrt{y}$$

$$\boxed{x = 3} \quad \boxed{y = 2}$$

$$x + y = 3 + 2 = 5$$

$$xy = 3 \cdot 2 = 6$$

Statement-I is false; statement-II is true.

85. The value of  $\cos^2 5^\circ + \cos^2 10^\circ + \cos^2 15^\circ + \dots + \cos^2 85^\circ + \cos^2 90^\circ$  is

- (1)  $9\frac{1}{2}$                                       (2) 9  
 (3)  $8\frac{1}{2}$                                       (4) 8

**Answer (3)**

$$\text{Sol. } (\cos^2 5^\circ + \cos^2 85^\circ) + (\cos^2 10^\circ + \cos^2 80^\circ) +$$

$$\dots + (\cos^2 40^\circ + \cos^2 50^\circ) + \cos^2 45^\circ$$

$$(1+1+\dots+1) + \frac{1}{2} = 8 + \frac{1}{2} = 8\frac{1}{2}$$

86. If  $(x + a)$  is the factor of the polynomials  $(x^2 + px + q)$  and  $(x^2 + mx + n)$  then the value of 'a' is

- (1)  $\frac{n-q}{m-p}$                                       (2)  $\frac{m-p}{n-q}$   
 (3)  $\frac{q-n}{m-p}$                                       (4)  $\frac{m-p}{q-n}$



**Answer (1)**

**Sol.** Given  $(x + a)$  is a factor of  $x^2 + px + q$  &  
 $x^2 + mx + x$

$$x^2 - pa + q = x^2 - ma + n$$

$$(m-p)a = n-q$$

$$a = \frac{n-q}{m-p}$$

87. The lowest common multiple of two numbers is 14 times their greatest common divisor. The sum of LCM and GCD is 600. If one number is 80 then other number is

- (1) 600                                      (2) 520  
(3) 280                                      (4) 40

**Answer (3)**

**Sol.** LCM = 14 GCD

$$\text{LCM} + \text{GCD} = 600$$

$$\Rightarrow 15\text{GCD} = 600$$

$$\boxed{\text{GCD} = 40}$$

$$\text{LCM} = 14 \cdot 40 = 560$$

$$\text{LCM} \times \text{GCD} = a \cdot b$$

$$\Rightarrow 560 \times 40 = 80 \times b$$

$$\boxed{b = 280}$$

88. The shaded portion in the given Venn diagram represents

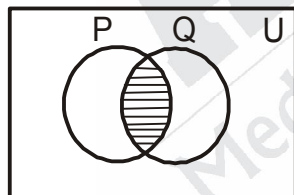

- (1)  $P' \cup Q'$                                       (2)  $P' \cap Q'$   
(3)  $(P' \cap Q)'$                                       (4)  $(P' \cup Q)'$

**Answer (4)**

**Sol.**  $(P' \cup Q)' = P \cap Q$

89. In  $\triangle ABC$ , the altitudes AL, BM and CN are intersect at 'O'. The value of  $AN \times BL \times CM$  is same as

- (1)  $BN \times LC \times AM$                                       (2)  $AL \times CN \times BM$   
(3)  $OL \times OM \times ON$                                       (4)  $OC \times OB \times OA$

**Answer (1)**

**Sol.**

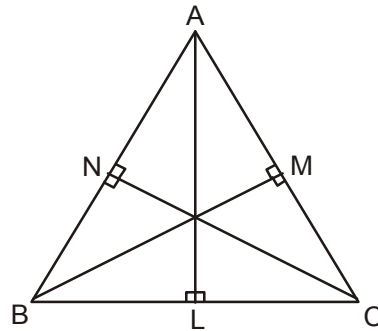

Clearly  $\triangle ALB$  is similar to  $\triangle CNB$  .....(1)

$$\frac{AL}{CN} = \frac{BL}{BN} = \frac{AB}{BC}$$

Clearly  $\triangle BMC$  is similar to  $\triangle ALC$  .....(2)

$$\frac{BM}{AL} = \frac{CM}{CL} = \frac{BC}{AC}$$

Clearly  $\triangle BMA$  is similar to  $\triangle CNA$

$$\frac{BM}{CN} = \frac{AM}{AN} = \frac{AB}{AC} \dots\dots\dots(3)$$

multiplying equation (1), (2) & (3)

$$\therefore \boxed{AN \cdot BL \cdot CM = BN \cdot LC \cdot AM}$$

90. If the letters of the word "FATE" are arranged as in a dictionary without repetition, then the rank of the arrangement of "FAET" is

- (1) 12    (2) 13  
(3) 14    (4) 15

**Answer (2)**

**Sol.** F A T E

$$A \square \square \square - 3! = 6$$

$$\square A \square \square - 3! = 6$$

$$\square \square A \square - = 1$$

$$\text{Rank} = 6 + 6 + 1 = 13$$

91. There are 12 points in a plane of which 4 are collinear. The number of straight lines and triangles can be formed from these points are respectively

- (1) 60 and 220    (2) 66 and 220  
(3) 65 and 216    (4) 61 and 216

**Answer (4)**

**Sol.** Total no. of points '12' out of which '4 are collinear

$$\text{No. of St. lines are } 12C_2 - 4C_2 + 1$$

$$= 66 - 6 + 1 = 61$$

$$\text{No. of triangles are} = 12C_3 - 4C_3$$

$$= 216$$



92. In  $\triangle ABC$ ,  $AC = BC$  and  $AD \perp BC$ . The value of  $AD^2 - BD^2$  is

- (1)  $2BD \times CD$                       (2)  $2AC \times CD$   
 (3)  $2(BD + CD)$                   (4)  $2(AC + CD)$

**Answer (1)**

**Sol.**

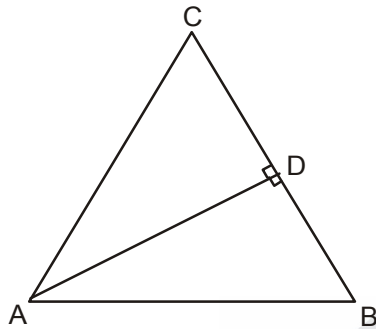

$$\begin{aligned} AD^2 - BD^2 &= (AC^2 - CD^2) - BD^2 \\ &= AC^2 - CD^2 - (BC - CD)^2 \\ &= -2CD^2 + 2BC \cdot CD \\ &= 2CD(BC - CD) = 2CD \cdot BD \end{aligned}$$

93. A box contains some black balls and 30 white balls. If the probability of drawing a black ball is two fifths of a white ball, then the number of black balls in the box is

- (1) 6                                      (2) 12  
 (3) 18                                    (4) 30

**Answer (2)**

**Sol.** Let number of balls be 'x'

$$\begin{aligned} \Rightarrow \frac{x}{x+30} &= \frac{2}{5} \times \frac{30}{x+30} \\ \Rightarrow x &= 12 \end{aligned}$$

94.

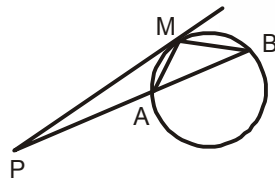

In the given figure, PM is a tangent to the circle and  $PA = AM$  then,

- A.  $\triangle PMB$  is isosceles  
 B.  $PA \times PB = MB^2$   
 (1) A is true, but B is false  
 (2) B is true, but A is false  
 (3) Both A and B are false  
 (4) Both A and B are true

**Answer (4)**

**Sol.** In  $\triangle APM$ ,  $PA = AM \Rightarrow \angle APM = \angle PMA$

By alternate segment theorem

$$\angle AMP = \angle MBA$$

In  $\triangle PMB$ ,  $\angle BPM = \angle PBM \Rightarrow PM = MB$

$\triangle PMB$  is an isosceles triangle

Clearly  $\triangle PBM$  is similar to  $\triangle PMA$

$$\frac{BP}{MP} = \frac{BM}{MA} = \frac{MP}{AP}$$

$$\boxed{AP \cdot BP = PM^2}$$

$$AP \cdot BP = MB^2$$

Both A and B are true

95. The correct relation is

- |                         |                            |
|-------------------------|----------------------------|
| <b>A</b>                | <b>B</b>                   |
| I. a, b, c are in G.P   | a. $2b = a + c$            |
| II. a, b, c are in A.P  | b. $a + c = \frac{2ac}{b}$ |
| III. a, b, c are in H.P | c. $b^{1/2} = ca$          |
|                         | d. $b = (ac)^{1/2}$        |

- (1) I-c, II-b, III-a  
 (2) I-c, II-a, III-d  
 (3) I-d, II-a, III-b  
 (4) I-d, II-b, III-c

**Answer (3)**

**Sol.** a, b, c are in G.P then  $b^2 = ac$

$$b = (ac)^{1/2}$$

a, b, c are in H.P then  $a + c = \frac{2ac}{b} \Rightarrow ab + bc = 2ac$

$$\Rightarrow \frac{1}{c} + \frac{1}{b} + \frac{2}{b}$$

96. The standard Deviation (S.D) and mean of two groups A and B are given below.

Group	Standard Deviation	Mean
A	3	70
B	4.2	60

The true statement among the following is

- I. A is more consistent than B  
 II. B is more consistent than A  
 III. A is more efficient than B  
 IV. B is more efficient than A

- (1) Only I and III are true
- (2) Only I and IV are true
- (3) Only II and III are true
- (4) Only II and IV are true

**Answer (1)**

**Sol.** C.A. =  $\frac{\sigma}{x} \times 100$

C.A. =  $\frac{\sigma}{x} \times 100$

Group A.....C.V. =  $\frac{3}{70} \times 100 = \frac{30}{7} = 4.2$

Group B.....C.V. =  $\frac{4.2}{60} \times 100 = \frac{42}{6} = 7$

A is more constant than B

A is more efficient than B.

97. The angle of elevation of the top of a tower from two points at a distance of 'a' and 'b' ( $a > b$ ) from its foot and in the same straight line from its are  $30^\circ$  and  $60^\circ$ . The height of the tower is

- |                 |                           |
|-----------------|---------------------------|
| (1) $a\sqrt{3}$ | (2) $\frac{b}{\sqrt{3}}$  |
| (3) $\sqrt{ab}$ | (4) $\frac{1}{\sqrt{ab}}$ |

**Answer (3)**

**Sol.**

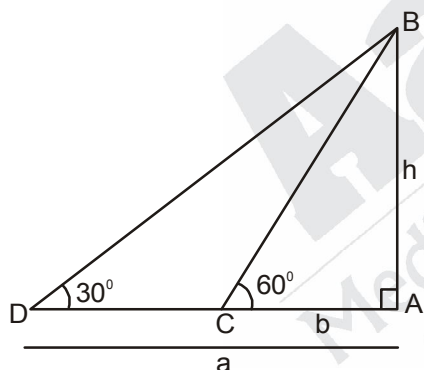

In  $\triangle ABC$ ,  $\frac{h}{b} = \sqrt{3} \Rightarrow h^2 = ab$

& In  $\triangle BAD$ ,  $\Rightarrow h = \sqrt{ab}$

$\frac{h}{a} = \frac{1}{\sqrt{3}}$

98. The condition of points (a,0), (0,b) and (1,1) lie on straight line will be

- |                 |                          |
|-----------------|--------------------------|
| (1) $ab = 1$    | (2) $\frac{a+b}{ab} = 1$ |
| (3) $a - b = 1$ | (4) $\frac{ab}{a-b} = 1$ |

**Answer (2)**

**Sol.** A(a,0), B(0,b), C(1,1) lie on a straight line slope of

$\overline{AB} = \text{slope of } \overline{BC}$

$\frac{b-0}{0-a} = \frac{1-b}{1-0}$

$\frac{b}{a} = \frac{1-b}{1}$

$\Rightarrow b = a - ab$

$\Rightarrow a + b = ab \Rightarrow \boxed{\frac{a+b}{ab} = 1}$

99. The ratio of income of two persons is 11 : 7 and the ratio of their expenditures is 9 : 5. If each of them manage to save Rs 400 per month then the sum of their monthly income is

- |               |               |
|---------------|---------------|
| (1) Rs. 3,600 | (2) Rs. 3,200 |
| (3) Rs. 2,800 | (4) Rs. 1,700 |

**Answer (1)**

**Sol.** Ratio of income = 11:7  $\Rightarrow 11x, 7x$

Ratio of expenditure = 9:5  $\Rightarrow 9y, 5y$

Solving,

$11x - 9y = 400 \dots\dots\dots(1)$

$7x - 5y = 400 \dots\dots\dots(2)$

$\Rightarrow (1) \times 5 \Rightarrow 55x - 45y = 2000$

$(2) \times 9 \Rightarrow 63x - 45y = 3600$

$\frac{-8x = -1600}{-8x = -1600}$

$\boxed{x = 200}$

Income = 2200 + 1400 = 3600

100. If  $y = a + a^2 + a^3 + \dots \dots \dots$  where  $|a| < 1$  then, the value of 'a' is

- |                     |                     |
|---------------------|---------------------|
| (1) $\frac{y}{1+y}$ | (2) $\frac{y}{1-y}$ |
| (3) $\frac{1+y}{y}$ | (4) $\frac{1-y}{y}$ |

**Answer (1)**

**Sol.**  $y = a + a^2 + a^3 \dots\dots\dots, |a| < 1$

$\Rightarrow y = \frac{a}{1-a}$

$\Rightarrow y - ay = a$

$\Rightarrow y = (y+1)a$

$\boxed{a = \frac{y}{y+1}}$

