



Aakash

Medical | IIT-JEE | Foundations

(Divisions of Aakash Educational Services Pvt. Ltd.)

Regd. Office : Aakash Tower, 8, Pusa Road, New Delhi-110005

Ph.: 011-47623456 Fax : 011-47623472

Time : 3 Hours

Answers & Solutions

Max. Marks : 200

for

NTSE (Stage-I) 2017-18

INSTRUCTIONS TO CANDIDATES

- Use blue/black ball point pen only. There is no negative marking.
- This test booklet contains 200 questions of one mark each. All the questions are compulsory.
- Part-I : MAT : 1 - 50 questions
Part-II : Language : 1 - 50 questions
Part-III : SAT : 1 - 100 questions
- Answer each question by darkening the one correct alternative among the four choices on the OMR Sheet with blue/black ball point pen.

Example :

Q. No.	Alternatives
Correct way :	1 ① ② ● ④
Q. No.	Alternatives
Wrong way :	1 ⊗ ⊕ ③ ④

Student must darkening the right oval only after ensuring correct answer on OMR Sheet.

- Disparity in mentioning (SC, ST & PH) in application form and OMR Sheet can make your candidature invalid.
- Students are not allowed to scratch/ alter/ change out an answer once marked on OMR Sheet, by using white fluid/ eraser/ blade/ tearing/ wearing or in any other form.
- Separate Sheet has been provided for rough work in this test booklet.
- Please handover the OMR Sheet to the invigilator before leaving the Examination Hall.
*Take all your question booklets with you.
- Darken completely the ovals of your answers on OMR Sheet in the time limit allotted for that particular paper.
- Your OMR Sheet will be evaluated through electronic scanning process. Incomplete and incorrect entries may render your OMR Sheet invalid.
- Use of electronic gadgets, calculator, mobile etc., is strictly prohibited.

PART-I : MENTAL ABILITY TEST (MAT)

Directions (Q.1 & Q.2) : In each of the following questions write which term in sequence replaces the questions mark?

1. BJ, DL, HP, PX, ?

- (1) FN (2) FX
(3) TB (4) VD

Answer (1)

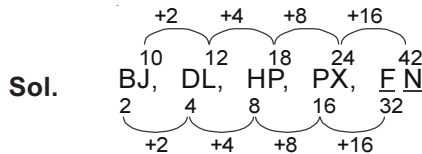

2. AYCD, EUGH, IQKL, ?

- (1) AYCD (2) BXDE
(3) MNAB (4) MZBC

Answer (4)



Directions (Q.3 to Q.5) : Find the odd term.

3. (1) 141 (2) 101
(3) 107 (4) 131

Answer (1)

Sol. All numbers are prime except 141.

4. (1) 6131 (2) 2191
(3) 3312 (4) 3164

Answer (4)

Sol. Product of digits of numbers in 18 except for 3164.

5. (1) DHLP (2) FNUB
(3) BDFH (4) KVGR

Answer (2)

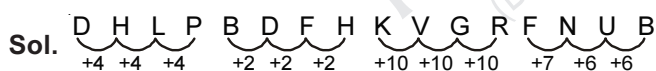

6. In the following question a specific group of number is given. From the given alternatives, find out the right number which matches the given group.

341, 572, 781

- (1) 634 (2) 891
(3) 909 (4) 990

Answer (2)

Sol. 341 → 11 × 31
572 → 11 × 52
781 → 11 × 71

In the same way 891 → 11 × 81

7. In a mathematical language if + means ÷, – mean ×, ÷ means + and × means – are used then,

$(200 + 5) \div 25 \div (20 - 5) \times 10 ?$

- (1) 125 (2) 100
(3) 155 (4) 40

Answer (3)

Sol. $(200 \div 5) + 25 + (20 \times 5) - 10 = 40 + 25 + 100 - 10 = 155$

Directions (Q.8 & Q.9) : In each of the following questions there is a specific relationship between the first and second figure. The same relationship exists between the third and the fourth figure which will replaced the question mark. Select the correct term from the given alternatives.



- (1) (2)
(3) (4)

Answer (1)

Sol. Vertices are joined to the center.



- (1) (2)
(3) (4)

Answer (4)

10. Six teachers of a workshop have sat down for a photo session as shown below. A is sitting in between K and S. M is at a corner. There is no one sitting in between N and S. Then where is the person 'J' sitting?

- (1) At the central position between K and M
(2) At the central position between N and A
(3) At the central position between S and K
(4) At the central position between M and A

Answer (1)

Sol. Seating arrangement → M J K A S N

11. Find out the correct number from the given alternatives to replace the question mark

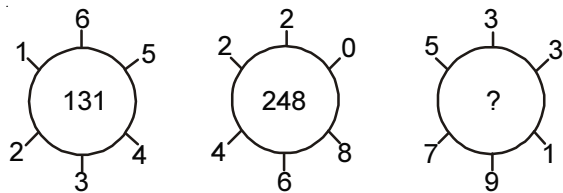

- (1) 132 (2) 262
(3) 274 (4) 320

Answer (2)

Sol.

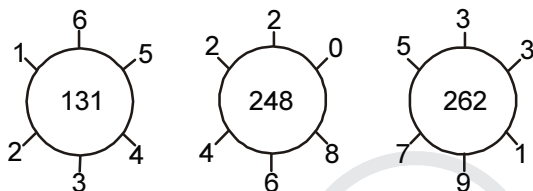

1st digit → 2 - 1 = 1	4 - 2 = 2	7 - 5 = 2
2nd digit → 6 - 3 = 3	6 - 2 = 4	9 - 3 = 6
3rd digit → 5 - 4 = 1	8 - 0 = 8	3 - 1 = 2

12. If the figure given along side is folded to construct a cube, find out the correct cubical figure from the given alternative figure.

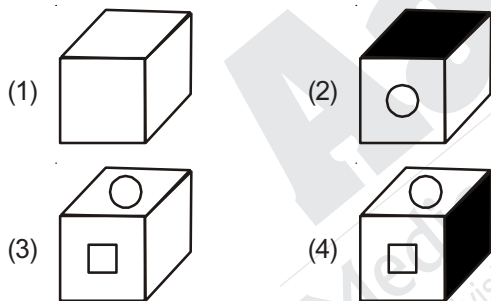
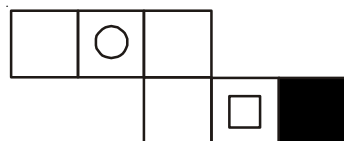

Answer (2)

13. In a certain code language ZEAL = 11, written then in that language BEAT = ?

- (1) 7 (2) 13
(3) 14 (4) 19

Answer (1)

Sol.

$$\begin{array}{cccc} Z & E & A & L \\ \downarrow & \downarrow & \downarrow & \downarrow \\ 26 & 5 & 1 & 12 \end{array} = 44 \rightarrow \frac{44}{4} = 11$$

$$\begin{array}{cccc} B & E & A & T \\ \downarrow & \downarrow & \downarrow & \downarrow \\ 2 & 5 & 1 & 20 \end{array} = 28 \rightarrow \frac{28}{4} = 7$$

14. On a playground J, K, L, M, O, P, Q, R are sitting in one row to watch a cricket match. L is at the right side of M and is occupying third place from N at the right side. K is sitting either at first or last position. Q is in between O and P. O is sitting at the third position at the left side of K. O is sitting next to 'J' at the right side. Who is sitting at the centre among them?

- (1) L (2) O
(3) J (4) Q

Answer (3)

Sol. Seating arrangement → N R M L J O Q P K

15. The following figure is rotated in anti clockwise direction and its mirror image is obtained. Select the correct mirror image from four alternatives given.

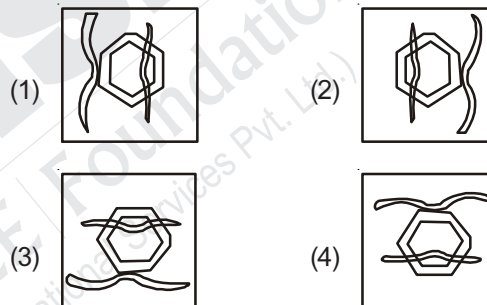

Answer (2)

Directions (Q.16 & Q.17) : In a certain code language the word EXPAND has been written in four different code languages. Understanding the code, find out the correct code language for the word given in each of the following questions.

EXPAND =

- (1) FYQBOE (2) EYRDRI
(3) EPNXAD (4) DWOZMC

16. (1) SOLVE = SPNYI

Answer (2)

$$\begin{array}{cccccc} S & O & L & V & E & \rightarrow & E & X & P & A & N & D \\ +0\downarrow & +1\downarrow & +2\downarrow & +3\downarrow & +4\downarrow & & +0\downarrow & +1\downarrow & +2\downarrow & +3\downarrow & +4\downarrow & +5\downarrow \\ S & P & N & Y & I & & E & Y & R & D & R & I \end{array}$$

17. (2) LARGE = KZQFD

Answer (4)

$$\begin{array}{cccccc} L & A & R & G & E & \rightarrow & E & X & P & A & N & D \\ -1\downarrow & -1\downarrow & -1\downarrow & -1\downarrow & -1\downarrow & & -1\downarrow & -1\downarrow & -1\downarrow & -1\downarrow & -1\downarrow & -1\downarrow \\ K & Z & Q & F & D & & D & W & O & Z & M & C \end{array}$$

Directions (Q.25 & Q.26) : In the following square numbers are written with a specific rule. Find the rule and decide which alternative will be in place of question mark.

25.

13	61	2
?	5	29
10	122	26

- (1) 49 (2) 58
(3) 71 (4) 102

Answer (2)

Sol. $5 \times 2 = 10$

$61 \times 2 = 122$

$13 \times 2 = 26$

$29 \times 2 = 58$

26.

-7	1	28
-4	17	8
?	56	73

- (1) -1 (2) 12
(3) 41 (4) 63

Answer (3)

Sol. $-7, -4, 1, 8, 17, 28, 41, 56, 73$
 $+3 \quad +5 \quad +7 \quad +9 \quad +11 \quad +13 \quad +15 \quad +17$

27. A square piece of paper is folded and cut at specific spots as shown in the figure. The paper when unfolded will look like as shown in area of the alternatives. Select the correct alternatives.

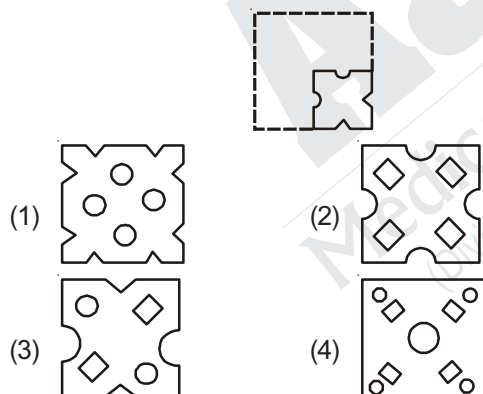

Answer (1)

Directions (Q.28 & Q.29) : In each of the following question, write which term in sequence replaces the question mark.

28. 2, 6, 21, 88, ?

- (1) 440 (2) 356
(3) 445 (4) 352

Answer (3)

Sol. 2, 6, 21, 88, ? \rightarrow 445
 $2 \times 2 + 2 \quad 6 \times 3 + 3 \quad 21 \times 4 + 4 \quad 88 \times 5 + 5$

29. 6, 30, 18, 128, ?

- (1) 36 (2) 38
(3) 98 (4) 90

Answer (2)

Sol. 6, 30, 18, 128, ?
 $\downarrow \quad \downarrow \quad \downarrow \quad \downarrow \quad \downarrow$
 $2^2+2 \quad 3^3+3 \quad 4^2+2 \quad 5^3+3 \quad 6^2+2 = 38$

Directions (Q.30 & Q.31) : Two charts are given below :

Containing two groups of letters. In chart one the rows and columns are labelled with 0 to 4 number. In chart two rows and columns are labelled with the numbers 5 to 9. The letter in the chart is identified first by its row number and then by its column number. For example 5 is denoted by 22,41 number.

Chart-I

	0	1	2	3	4
0	F	O	M	S	R
1	S	R	F	O	M
2	O	M	S	R	F
3	R	F	O	M	S
4	M	S	R	F	O

Chart-II

	5	6	7	8	9
5	A	T	D	I	P
6	I	P	A	T	D
7	T	D	I	P	A
8	P	A	T	D	I
9	D	I	P	A	T

30. Which group of words represent the word MOST?

- (1) 40, 44, 22, 89
(2) 33, 20, 11, 79
(3) 21, 00, 03, 88
(4) 02, 13, 34, 56

Answer (4)

31. Which groups of words represent the word ROAD?

- (1) 42, 32, 79, 58
(2) 23, 32, 98, 99
(3) 11, 13, 67, 69
(4) 04, 20, 55, 78

Answer (3)

32. A school boy was having Deepavali vacation from 11 October to 28 October 2012. It was Monday on the 10th Day before the start of the vacation. After the vacation, the school excursion was arranged on the 7th day from the reopening of the school. On which Day was the school excursion arranged.

- (1) Sunday
(2) Friday
(3) Thursday
(4) Tuesday

Answer (1)

Directions (Q.33 & Q.34) : In each of the following, the question figures change in a particular order. Decide which figure from the given alternatives will replace the question mark.

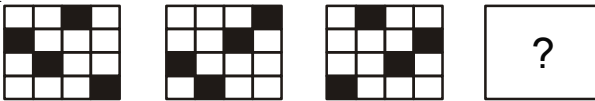
33. 

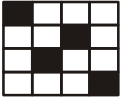
(1) 

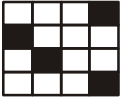
(2) 

(3) 

(4) 

Answer (3)

Sol. Shaded square is shifting columnwise.

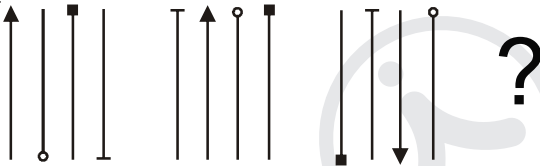
34. 

(1) 

(2) 

(3) 

(4) 

Answer (2)

Sol. Arrow is shifting right and is rotated by 180° alternatively.

Directions (Q.35 & Q.36) : In each of the following questions there is a specific relationship between the first and second term. The same relationship exists between third and fourth term. Understanding this relationship, Find out the correct alternative to replace the question mark.

35. AMK : SPJ :: KNM : ?

(1) CQN (2) BQL
(3) CQL (4) BLQ

Answer (3)

Sol. AMK : SPJ :: KNM : CQL

$\begin{matrix} \text{A} & \text{M} & \text{K} & & \text{S} & \text{P} & \text{J} \\ & \nearrow & \nearrow & \nearrow & & \nearrow & \nearrow \\ & +18 & +3 & -1 & & +18 & +3 & -1 \end{matrix}$

36. N9M : P11Q :: V14T : ?

(1) X17Z (2) X16W
(3) X15Y (4) X16X

Answer (4)

Sol. N9M : P11Q :: V14T : X16X

$\begin{matrix} \text{N} & 9 & \text{M} & & \text{P} & 11 & \text{Q} \\ & \nearrow & \nearrow & \nearrow & & \nearrow & \nearrow \\ & +2 & +2 & +4 & & +2 & +2 & +4 \end{matrix}$

37. Seema went 9 km to west. She turned to right and went 7 km. She turned to left and went 8 km. From there she turned back and went 11 km. Then she turned to right and went 7 km.

How much distance is she from origin?

(Seema turns every time in 90° angle)

- (1) 9 km (2) 6 km
(3) 3 km (4) 7 km

Answer (2)

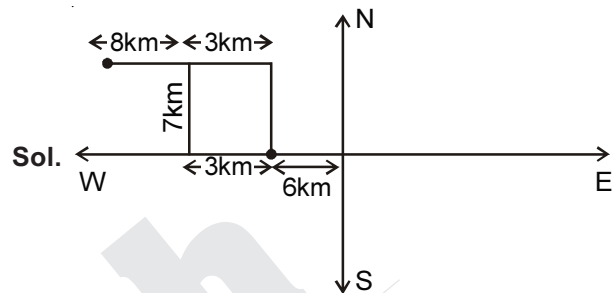

38. A rhythmic arrangement of number given. The missing numbers appear in the same order in one of the alternative answer. Find the correct alternative.

0 - 0100 - 10 - 1111 - -

- (1) 01011 (2) 01101
(3) 01111 (4) 01110

Answer (3)

Sol. 000100110011111111 1 Number of zeroes are decreasing.

Directions (Q.39 & Q.40) : Madhav and Govind play Hockey and Volleyball. Hemant and Madhav play Hockey and Baseball. Ramesh and Govind play Cricket and Volleyball. Hemant, Ramesh and Anand play Football and Baseball. Then, answer the following questions.

39. Who plays Hockey, Cricket and Volleyball?

- (1) Madhav (2) Govind
(3) Hemant (4) Anant

Answer (2)

Sol.

	Hockey	Volleyball	Baseball	Cricket	Football
Madhav	✓	✓	✓		
Govind	✓	✓		✓	
Hemant	✓		✓		✓
Ramesh		✓	✓	✓	
Anant			✓		✓

40. Who does not play Baseball? Choose the correct alternative.

- (1) Govind (2) Hemant
(3) Madhav (4) Ramesh

Answer (1)

Directions (Q.41 & Q.42) : In the following figure, three different position of a cube has been shown. Observe the figure and answer questions that follow.

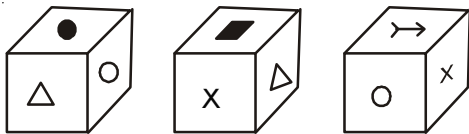

41. Which sign will be on the surface opposite to surface having X sign?

- (1) ○ (2) ●
(3) △ (4) →

Answer (2)

42. Which sign will be on the surface opposite to surface having ■ sign

- (1) ○ (2) ●
(3) → (4) X

Answer (1)

43. In the figure given below, a transparent square shaped paper is folded along the dotted lines. What figure will be obtained? Find the figure from the alternative figure given.

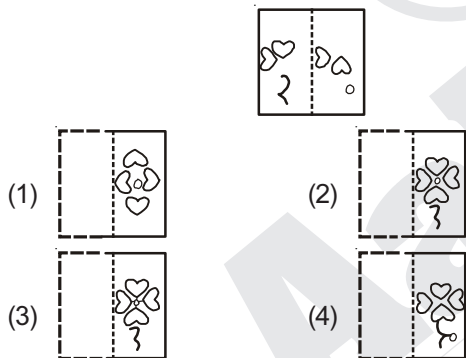

Answer (4)

Directions (Q.44 & Q.45) : In each of the following questions there is a specific relationship between the first and second number. The same relationship exists between the third and fourth number which will replace the question mark. Select the correct term from the alternatives given.

44. 583 : ? :: 488 : 378

- (1) 291 (2) 293
(3) 487 (4) 581

Answer (2)

Sol. $5 + 8 + 3 = 16$ and $4 + 8 + 8 = 20$
 $2 + 9 + 3 = 14$ and $3 + 7 + 8 = 18$
↓ - 2 and ↓ - 2

45. 13 : 19 :: 13 : ?

- (1) 41 (2) 37
(3) 33 (4) 47

Answer (1)

Sol. 13, 11, 19 → 31, 37, 41 (Prime numbers)

46. In the following question in every row the numbers outside the bracket are related to number inside the bracket in a specific manner. From the given alternatives find the right number which matches and will replace the question mark.

64 (87) 343 49 (76) 216 36 (?) 512

- (1) 68
(2) 59
(3) 52
(4) 48

Answer (1)

Sol. $\sqrt{64} = 8, \sqrt[3]{343} = 7 \rightarrow 87$

Similarly, $\sqrt{36} = 6, \sqrt[3]{512} = 8 \rightarrow 68$

47. After folding a square piece of paper, it appears as shown in the left side question figure. The paper when unfolded will look like as shown in one of the alternatives. Select the correct alternative.

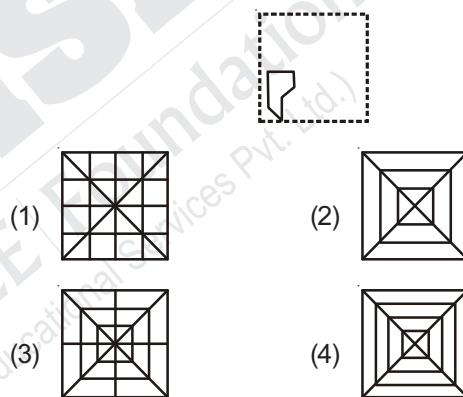

Answer (3)

48. The following question figure given at left side is incomplete. Select the correct alternative which can complete the figure.

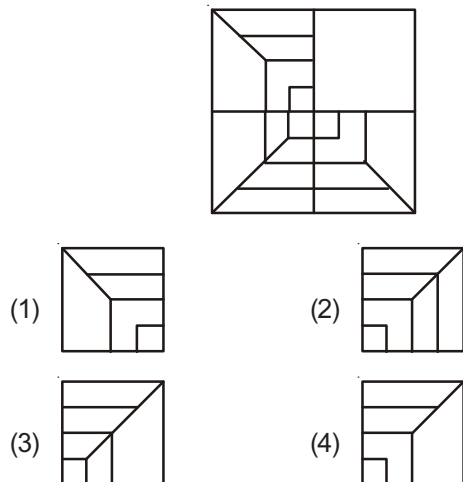

Answer (4)

Directions (Q.49 & Q.50) : In the following diagram, three geometrical figure have been drawn intersecting each other. The labels have been given to different parts. Each figure represent a specific group of people. Observe the figure closely and answer the questions that follow.

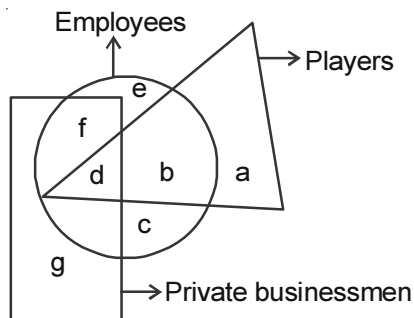

49. How many employee players do private business?
 (1) b
 (2) a
 (3) c
 (4) d

Answer (4)

50. How many players are unemployed?
 (1) b
 (2) d
 (3) a
 (4) c

Answer (3)

PART-II : LANGUAGE TEST

Directions (Q.1 to Q.5) :

Read the passage and answer the questions based on it.

Parents of children who were saved by fisherman Abdul Sattar flocked the Triveni Kala Sangam on Wednesday Afternoon to greet Abdul Bhai, who rescued most of the children in last week's school bus tragedy.

Abdul was awarded the Times Hero Award by Rajya Sabha Deputy Chairperson Najma Heptullah. 'I find a God in this man', said Raj Kumari Devi, whose ten year old son, Arun, was rescued by him, 'This man emerged like an angel. None of us knew swimming. We did not know how to reach the scene of the accident, which was in the middle of the river', said Arun's father, Chand Sharma was another happy soul. Her two sons were saved by Sattar. Chand says, "We were helplessly roaming around the river bank, while this man was struggling to save my children. I shall never forget contribution of this man to our life. We go to the temple, bu these are the true Gods amongsts us. I wish I could give him every little belonging that I have. He is great.' Abdul Sattar is a simple fisherman. He has spent twenty five of his life worrying over his daily meal, what he wears and a fixed dwelling unit for his family. But the man made a mark when the recent school tragedy ocured in the Yamuna. He saved the lives of most of the children, who were drowning in the river.

1. What is Abdul Sattar?
 (1) A teacher
 (2) A fisherman
 (3) A carpenter
 (4) A driver

Answer (2)

Sol. A fisherman

2. Pick out the antonym for 'remember'?
 (1) Save
 (2) Rescue
 (3) Forget
 (4) Forgot

Answer (3)

Sol. Forget

3. Which award is mentioned in the passage?
 (1) Times Hero award
 (2) Times Heroine award
 (3) Padmashri award
 (4) Padmabhushan award

Answer (1)

Sol. Times Hero award

4. "He is great", who has made this statement?
 (1) Abdul Sattar
 (2) Najma Heptullah
 (3) Rajkumari Devi
 (4) Chand Sharma

Answer (4)

Sol. Chand Sharma

5. Which of these pairs is the odd man out?
 (1) Last week
 (2) Little belonging
 (3) Happy soul
 (4) Little family

Answer (1)

Sol. Last week

Directions (Q.6 to Q.10) :

Read the passage and answer the questions based on it.

Anaemia is a major public health problem that affects women and children throughout their life. In young boys and girls, anaemia limits their growth development, reduces their concentration, affects their learning capabilities and makes them susceptible towards infection, thereby increasing school drop-out rates, reducing their physical fitness and work productivity.

In girls, anaemia leads to early delivery in future, birth of low weight babies, higher infant mortality rates and higher maternal mortality rates

Anamia is a preventable disorder. Adding rich food items to the diet and taking iron-folic items to the diet and taking iron- folic acid table regularly go a long way in maintaining natural haemoglobin levels and reducing prevalence of anaemia.

6. The major public health problem mentioned in the passage is
- | | |
|-------------|---------------|
| (1) Anaemia | (2) Typhoid |
| (3) Malaria | (4) Swine flu |

Answer (1)**Sol.** Anaemia

7. In young boys and girls Anaemia affects their
- | | |
|---------------------------|---------------------------|
| (1) Teaching capabilities | (2) Learning capabilities |
| (3) Eating habits | (4) Physical fitness |

Answer (2)**Sol.** Learning capabilities

8. We should take tablets regularly
- | | |
|-------------|---------------------|
| (1) Calcium | (2) Iron-folic acid |
| (3) Vitamin | (4) Tonic |

Answer (2)**Sol.** Iron-folic acid

The answer is given is the last third line of the comprehension.

9. We can prevent Anaemia by maintaining natural
- | |
|-------------------------------|
| (1) Oxygen level |
| (2) Red and white blood cells |
| (3) Haemoglobin level |
| (4) Calcium level |

Answer (3)**Sol.** Haemoglobin level

The answer is given in the last second line of the comprehension

10. Which word in the passage means 'curable'?
- | | |
|-----------------|-----------------|
| (1) Major | (2) Susceptible |
| (3) Preventable | (4) Natural |

Answer (3)**Sol.** Preventable

The closest meaning to the word curable in the passage is preventable.

Directions (Q.11 to Q.15) :

Read the passage and answer the questions based on it.

Shree was working in the stone quarries at Turbhe. He had a son, Shekhar. He was blind from birth. His father had never let him out of the house as he was afraid of his safety. One day when he was twelve, five boys from the local Municipal School came to Shekhar's house. They were shocked to know that he had never stepped out of his house since, his birth. The boys were members of an 'Arambh' project that tries to get children to be educated. They told Shree that he should send his boy to school. Shree didn't like the idea. He belonged to a poor family. After repeated visits, the boys again visited and told Shree that the school admission was free. Shekhar was very clever. He got 2nd rank in his S.S.C. Exam. The school headmistress called Shree and said, "Your son has proved the best in the school and I am proud of him, He was really a hard working boy."

11. Where was shree working?

- | |
|-----------------------------|
| (1) In the stone quarry |
| (2) In the stone lorry |
| (3) In the municipal school |
| (4) In an 'Arambh' project |

Answer (1)**Sol.** In the stone quarry

The answer is given in the first line of the passage.

12. How many boys came to Shekhar's house?

- | | |
|------------|-----------|
| (1) Twelve | (2) Five |
| (3) Two | (4) Seven |

Answer (2)**Sol.** Five

The answer is on the third line of the passage given

13. The phrase 'to let one out' means

- | |
|----------------------------------|
| (1) To be shocked |
| (2) To go out |
| (3) To give permission to go out |
| (4) To agree |

Answer (4)**Sol.** To agree

The meaning of the phrase 'to let one out' means to give permission to go out. In the passage the boys father not permit his blind child to go out as he was afraid of his safety.

14. The boys were shocked to know that
- (1) He belonged to a poor family
 - (2) He had never stepped out of his house, since his birth
 - (3) He had never visited school
 - (4) None of the above

Answer (2)

Sol. He had never stepped out of his house, since his birth

The answer is on the fourth line of the passage.

15. The school head mistress was proud of Shekhar as
- (1) He was blind from his birth
 - (2) He was an honest boy
 - (3) He was really a hard working boy
 - (4) He was an educated person now

Answer (3)

Sol. He was really a hard working boy

The Clearly given in the passages second last and last line.

16. S1 : Once I decided to prepare tea myself for my friends.
S2 :
S3 :
S4 :
S5 : Finally I strained tea and served it with biscuits.
P : I added five tea spoons of sugar and three tea spoons of tea powder.
Q : I took three cups of water in a vessel.
R : Then I switched on the gas stove and boiled water.
- (1) PQR
 - (2) QRP
 - (3) PRQ
 - (4) QPR

Answer (4)

Sol. QRP

He decided to make tea. Switched on the gas, added ingredients and finally served it.

17. S1 : The menace of plastic in the state came to the fore when thin plastic bags choked the drains and caused water logging.
S2 :
S3 :
S4 :
S5 : But the anti plastic movement is gaining steam in cities.

- P : Later the government decided to ban only bags of thickness less than 50 microns.
Q : In the aftermath of the incident the government proposed a complete ban on plastics.
R : However it may be a long time before plastic is completely banned in the state due to its widespread utility.

- (1) PRQ
- (2) PQR
- (3) QPR
- (4) QRP

Answer (4)

Sol. QPR

First government proposed complete ban then decided to ban bags of thickness less than 50 microns and finally concluded that it may take long time.

18. A : Sparrow was the first bird I was introduced to
B :
C : Later the roads were widened and the birds left our area.
- (1) Sparrows love feeding on grains.
 - (2) As a child I would keep watching them after my school hours.
 - (3) Fruiting trees attract many birds
 - (4) I know it doesn't understand our language

Answer (2)

Sol. As a child I would keep watching them after my school hours.

Since writer is talking about his childhood. Option (2) is most relevant.

19. A : The leopard was found in the basement of the school.
B :
C : After an 18 hours operation forest department officials finally captured the leopard.
- (1) The leopard had entered in the premises of NES School
 - (2) The leopard had entered in the premises of police station.
 - (3) The leopard was kept in a cage.
 - (4) Even today leopards are being hunted everyday

Answer (1)

Sol. The leopard had entered in the premises of NES School

In statement A they mentioned school therefore option (1) is most appropriate.

20. Superstitions introduce fears in the mind and weaken it by the power of suggestion.

- (1) Rational (2) Vague
(3) Valid (4) Weak

Answer (2)

Sol. Vague

Most suitable answer is vague meaning unclear, indefinite and uncertain.

21. My greatest guru is my mother. She gave me of life.

- (1) Values (2) Meals
(3) Education (4) Message

Answer (1)

Sol. Values

Values is the most appropriate answer as values are given by mother.

22. If we had the that however difficult things are right now, it will not remain so forever.

- (1) Impression (2) Conviction
(3) Belief (4) Thought

Answer (3)

Sol. Belief

Belief is the only option suiting the situation.

23. While you deliver a speech, always be.....

- (1) Shy (2) Nervous
(3) Confident (4) Stubborn

Answer (3)

Sol. (3) Confident

Confident is the only positive quality.

24. We should have 'balanced diet' every day. Here balanced diet means

- (1) Delicious food
(2) Limited nutritious food
(3) Food that is oily and Spicy
(4) Local food

Answer (2)

Sol. (2) Limited nutritious food

All the other options are unhealthy

25. Many people consume packaged food because.....

- (1) It was become a matter of convenience
(2) It has become a matter of convenience
(3) It is become a matter of convenience
(4) It had become a matter of convenience

Answer (2)

Sol. (2) It has become a matter of convenience

Present Continuous

26. Previously they used to live Paris.

- (1) with (2) by
(3) within (4) in

Answer (4)

Sol. (4) in

Paris is a place to live 'in'.

27. She always avoids artificial products and goes only for the natural?

- (1) does she? (2) doesn't she?
(3) don't she? (4) will she?

Answer (2)

Sol. (2) doesn't she?

The sentence is positive which requires

28. If it rains tomorrow, we paper boats.

- (1) prepare (2) will prepare
(3) could preparing (4) are preparing

Answer (2)

Sol. (2) will prepare

Future Simple.

29. you like to have tea or coffee?

- (1) can (2) will
(3) would (4) should

Answer (3)

Sol. Would

30. She has got green fingers. This means

- (1) She's got no experience of life.
(2) She steals things.
(3) She's good at gardening.
(4) She's got fingers green in colour.

Answer (3)

Sol. She's good at gardening

31. Peace and Progress always go **hand in hand**.

- (1) go together
(2) depart from each other
(3) separate from each other
(4) go parallel

Answer (1)

Sol. go together

32. He has been learning English **off and on** for sometime past.

- (1) regularly (2) irregularly
(3) steadily (4) carefully

Answer (2)

Sol. irregularly

33. **By and by** the teacher came into the room, and there was pin drop silence in the class.

- (1) before time
- (2) some time afterwards
- (3) in time
- (4) in a short time

Answer (4)

Sol. in a short time

34. After a lot of efforts when his scheme has **fallen through**, he felt very sad.

- (1) succeeded
- (2) collapsed
- (3) failed
- (4) passed

Answer (3)

Sol. Failed

35. His **maiden speech** in the parliament was a great success.

- (1) first speech(2) last speech
- (3) good speech(4) long speech

Answer (1)

Sol. First speech

Directions (Q.36 to Q.43) :

The earth is the (36) _____ planet of the solar system. No other planet other than the (37) _____ has life on it. As the earth is a (38) _____ there is magnetic field around the earth. It diverts the harmful rays from the (39) _____ towards the polar regions of the earth. The sun which is at the centre of the solar system is a yellow coloured (40) _____. Mercury is (41) _____ to the sun. (42) _____ is the largest planet of the solar system. Mars is called the (43) _____ planet.

Direction

- 36. (1) first
- (2) second
- (3) third
- (4) last

Answer (3)

Sol. Third

- 37. (1) earth
- (2) Neptune
- (3) Uranus
- (4) Saturn

Answer (1)

- 38. (1) Star
- (2) Planet
- (3) Magnet
- (4) Asteroid

Answer (2)

- 39. (1) Moon
- (2) Sun
- (3) Mercury
- (4) Mars

Answer (2)

- 40. (1) star
- (2) planet
- (3) satellite
- (4) super nova

Answer (1)

- 41. (1) largest
- (2) closest
- (3) farthest
- (4) smallest

Answer (2)

- 42. (1) Jupiter
- (2) Mars
- (3) Earth
- (4) Venus

Answer (1)

- 43. (1) yellow
- (2) blue
- (3) white
- (4) red

Answer (4)

- 44. I have kept a reserve funnel in case accidents.
- (1) with
- (2) of
- (3) in
- (4) to

Answer (2)

Sol. of

- 45. The is a person who is mending shoes.
- (1) shopkeeper
- (2) carpenter
- (3) cobbler
- (4) buyer

Answer (3)

Sol. Cobbler meaning a person whose job is Mending Shoes.

- 46. The train at 6.30 A.M. everyday, so the platform is crowded.
- (1) arrives
- (2) arrived
- (3) arriving
- (4) will arrive

Answer (1)

Sol. Shows habitual/scheduled action

- 47. Little Rohan is very much interested to watch the ships in the ocean.
- (1) saling
- (2) selling
- (3) sailing
- (4) celling

Answer (3)

Sol. Sailing

- 48. My mantra to be happy is very **simple**.
- (1) imperfect
- (2) unhappy
- (3) difficult
- (4) worst

Answer (3)

Sol. Antonyms of simple is difficult.

- 49. Solar energy is modular and **scalable** and can be generated at the point of use.
- (1) measurable
- (2) immeasurable
- (3) countable
- (4) valuable

Answer (1)

Sol. Considering the synonyms of the under line word.

- 50. Our problems are so **colossal** and we are very small.
- (1) strong
- (2) extremely large
- (3) small
- (4) difficult

Answer (2)

Sol. Considering the synonyms of the underlined word.

PART-III : SCHOLASTIC APTITUDE TEST (SAT)

1. Twinkling stars are seen due to _____
- (1) Irregular emission of light from stars
 - (2) Weather changes
 - (3) Stars are far away
 - (4) Refractive index of air in the given region goes on changing and randomly.

Answer (4)

Sol. Refractive index of air in the given region goes on changing and randomly. That is it varies with altitude.

2. Government of India celebrates 28 February as 'National Science Day' in the memory of
- (1) Dr. Hargovind Khurana
 - (2) Dr. C.V. Raman
 - (3) Dr. Vikram Sarabhai
 - (4) Dr. A.P.J. Abdul Kalam

Answer (2)

Sol. Fact

3. $F = G \frac{m_1 \times m_2}{R^2}$ is the formula to prove _____
- (1) Newton's First law of motion
 - (2) Newton's Second law of motion
 - (3) Newton's Third law of motion
 - (4) Newton's Law of Gravitation

Answer (4)

Sol. Newton's law of gravitation.

$$F \propto m_1 m_2 \quad \dots(i)$$

$$F \propto \frac{1}{r^2} \quad \dots(ii)$$

Now, combining equation (i) and (ii), we get

$$F \propto \frac{m_1 m_2}{r^2}$$

$$\therefore F = \frac{Gm_1 m_2}{r^2}$$

4. Calculate pressure exerted by a screw on the wooden plank if area of contact of the screw is 0.5 mm^2 and its weight is 50 N.
- (1) $100 \times 10^6 \text{ N/m}^2$
 - (2) $50 \times 10^6 \text{ N/m}^2$
 - (3) $100 \times 10^6 \text{ N}$
 - (4) $50 \times 10^6 \text{ N}$

Answer (1)

Sol. $F = 50 \text{ N}$

$$A = 0.5 \text{ mm}^2 \\ = 0.5 \times 10^{-6} \text{ m}^2$$

$$\therefore \frac{F}{A} = P \Rightarrow P = \frac{50}{0.5 \times 10^{-6}} = 100 \times 10^6 \frac{\text{N}}{\text{m}^2}$$

5. The distance of distinct vision is _____ cm.
- (1) 20
 - (2) 25
 - (3) 30
 - (4) 35

Answer (2)

Sol. Fact

6. Observe the Columns I, II and III, match them and select the correct answer from given options.

I		II		III	
A.	Resistors in series	(a)	Required to move a unit positive charge from one point to another point	(i)	$Q = R1/A$
B.	Potential difference	(b)	Used to increase effective resistance in a circuit	(ii)	$I = Q/t$
C.	Electric current	(c)	Net charge flowing through any cross section of a conductor in the given time	(iii)	$R(s) = R_1 + R_2 + R_3 \dots R(n)$
D.	Resistivity	(d)	Depends on the material of the conductor	(iv)	$V = W/Q$

- (1) A – b – iii, –a–iv, C – c – ii, D – d – i
- (2) A – c – iv, b – b – iii, C – d – i, D – a – ii
- (3) A – d – ii, B – b – i, C – a – iii, D – c – iv
- (4) A – a – i, B – b – iii, C – d – iv, D – c – ii

Answer (1)

Sol. Fact

7. MRI stands for _____
- (1) Managing Response Index
 - (2) Magnetic Resonance Index
 - (3) Magnetic Resonance Imaging
 - (4) Managing Response Imaging

Answer (3)

Sol. Magnetic Resonance Imaging

8. Which of the following is not property of magnetic lines of force.
- (1) The tangent at any point on the magnetic lines of pole gives the direction of the magnetic field at that point.
 - (2) No two magnetic lines of pole can intersect each other.
 - (3) Magnetic lines of force are crowded where the magnetic field is strong and far from each other where field is weak
 - (4) They are closed continuous curves. They start from south pole and end on north pole.

Answer (4)

Sol. Following is not property of magnetic lines of force.

*They are closed continuous curves. They start from south pole and end on north pole

9. Select the incorrect statement stated below related to concave mirror.

- (1) Outer surface is coated with opaque substance
- (2) Inner surface is polished and thus reflective.
- (3) It is called as converging mirror
- (4) It is used to observe the phenomenon of refraction.

Answer (4)

Sol. Incorrect statement

It is used to observe the phenomenon of refraction

10. Observe the diagram of ' Electric DC generator, and select the correct pairing of labelling.

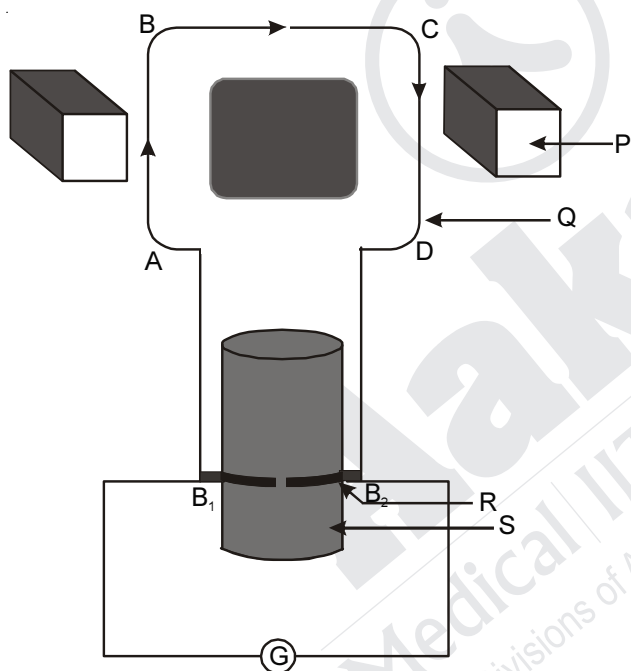

- (1) P-Strong magnet, Q-Armeature, R-Splitring, S-Axle
- (2) P-Iron core, Q-Armeature, R-Splitring, S -Axle
- (3) P-Strong magnet, Q-Iron core, R-Axle, S-Wire
- (4) P-Iron core, Q-Axle, R-Splitring, S-Strong magnet

Answer (1)

Sol. P – Strong magnet

Q – Armeature

R – Splitring

S – Axle

11. A current of 0.4A is flowing through a bulb for 3 minutes. Find the charge that is flowing through the circuit.

- (1) 12C.
- (2) 36C.
- (3) 72C.
- (4) 450C.

Answer (3)

Sol. $q = ?$

$$I = 0.4 \text{ A}$$

$$t = 3 \text{ min} = 3 \times 60 \text{ seconds} = 180 \text{ seconds}$$

$$\therefore Q = I t$$

$$= 0.4 \times 180$$

$$= 72\text{C}$$

12. Observe the adjacent ray diagram and select the correct option of position, nature and size of images.

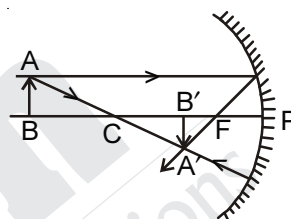

- (1) Beyond C, Real and Inverted, Enlarged
- (2) Between C and F, Real and inverted, Diminished
- (3) Beyond C, Real and inverted, Enlarged
- (4) Between C and F, Virtual and Erect, Diminished

Answer (2)

Sol. Fact

13. Observe the circuit diagram and select the incorrect option given below in answers.

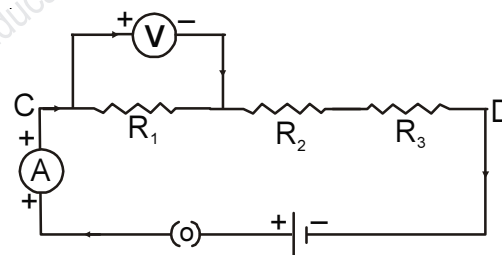

- (1) Electric circuit is open.
- (2) Resistors R_1 , R_2 and R_3 are connected in series
- (3) Ammeter 'A' is connected in series.
- (4) Voltmeter 'V' is connected in parallel.

Answer (1)

Sol. Incorrect option

Given circuit is closed (.)

14. Which of the following Element loses and electron most easily.

- (1) Na
- (2) Mg
- (3) K
- (4) Ca

Answer (3)

Sol. Potassium has more size it can loose electron easily

15. Which of the following species does not have electrons equal to 18.

- (1) K^+ (2) Cl^-
 (3) Ca^{2+} (4) K

Answer (4)

Sol. Potassium contains 19 electrons.

16. Which of the following is a double displacement reaction.

- (1) $NH_3 + HCl \longrightarrow NH_4Cl$
 (2) $CuSO_{4(aq)} + Fe(s) \longrightarrow FeSO_4 + Cu$
 (3) $Na_2SO_4 + BaCl_2 \longrightarrow BaSO_4 + 2 NaCl$
 (4) $CaCO_{3(s)} \xrightarrow{\Delta} CaO_{(s)} + CO_{2(g)}$

Answer (3)

Sol. Fact

17. The colour of anhydrous copper sulphate is _____

- (1) Blue (2) White
 (3) Pink (4) Green

Answer (2)

Sol. Fact

18. Ajay has a sting by red ant, it causes itching & irritation. The sting consist of which of the following acid.

- (1) Acetic acid (2) Butyric acid
 (3) Carbonic acid (4) Formic acid

Answer (4)

Sol. Stings of red ants contain formic acid

19. Which of the following compound is alkaline in aqueous medium.

- (1) Na_2CO_3 (2) $NaCl$
 (3) H_2CO_3 (4) $CuSO_4$

Answer (1)

Sol. Na_2CO_3 is produced from strong base $NaOH$ and weak acid H_2CO_3 . So the resulting solution is alkaline in nature.

20. Which of the following compound conduct electricity in aqueous solution which is a covalent compound.

- (1) Calcium Chloride
 (2) Hydrogen Chloride
 (3) Magnesium Oxide
 (4) Lithium Fluoride

Answer (2)

Sol. Hydrogen chloride completely ionises in aqueous state to form H^+ and Cl^- . So it conducts electricity.

21. Which of the following metal does not react with dilute HCl .

- (1) Copper (2) Aluminium
 (3) Iron (4) Zinc

Answer (1)

Sol. Copper is less reactive than hydrogen. So it cannot displace hydrogen from HCl . Copper is present below the hydrogen in reactivity series.

22. Select a pair homologous from the following.

- (1) C_3H_6 and C_4H_{10}
 (2) CH_3COOH and C_2H_5COOH
 (3) C_4H_8 and C_3H_4
 (4) $(CH_3)_2CO$ and C_3H_7CHO

Answer (2)

Sol. CH_3COOH and C_2H_5COOH have same functional group and differ by $-CH_2$ group.

23. According to IUPAC rule, which of the following compound is prop - 1 - ene.

- (1) $CH_3 - CH_2 - CH_3$
 (2) $CH_3 - CH = CH_2$
 (3) $CH_3 - CH = CH - CH_3$
 (4) $CH_3 - C \equiv CH$

Answer (2)

Sol. $\overset{3}{C}H_3 - \overset{2}{C}H = \overset{1}{C}H_2$ prop-1-ene

24. Stainless steel alloy is a mixture of.

- (1) $Fe + C + Cr + Ni$ (2) $Ni + C + Cr + Al$
 (3) $Fe + Cu + Al + C$ (4) $Fe + Zn + C + Ni$

Answer (1)

Sol. Fact

25. Which of the following elements will form an acidic oxide.

- (1) An element with atomic number 7
 (2) An element with atomic number 3
 (3) An element with atomic number 12
 (4) An element with atomic number 19

Answer (1)

Sol. Nitrogen is the element with atomic number 7 that forms acidic oxide like N_2O_5 .

26. Which of the following general formulae represents the alkyl group.

- (1) C_nH_{2n} (2) C_nH_{2n+1}
 (3) C_nH_{2n+2} (4) C_nH_{2n-1}

Answer (2)

Sol. Fact

27. Raw material required for photosynthesis is and water.
- (1) Chloroplast (2) Sunlight
(3) Nitrogen (4) Carbon-dioxide

Answer (4)

Sol. Apart from water, the other raw material required for photosynthesis is carbon dioxide.

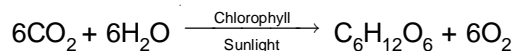

28. Find the odd man.
- (1) Uterus (2) Ovary
(3) Vagina (4) Testis

Answer (4)

Sol. Uterus, ovary and vagina are parts of female reproductive system. Testis is a part of male reproductive system.

29. The prescribed limit of sound in decibels in silent zone during daytime is.
- (1) 50 (2) 114
(3) 104 (4) 109

Answer (1)

Sol. Fact

30. A green house gas N_2O remains for how many years in the atmosphere?
- (1) 100 (2) 114
(3) 104 (4) 109

Answer (2)

Sol. Fact

31. In human being blood goes through the heart times during each cycle.
- (1) one (2) three
(3) two (4) four

Answer (3)

Sol. Humans have four chambered heart. Human heart shows double circulation in which blood passes twice through the heart during each cardiac cycle.

32. Response to stimulus of touch is called
- (1) Tropic movement
(2) Photo-tropic movement
(3) Hydro-tropic movement
(4) Seismonastic movement

Answer (4)

Sol. Movement in response to stimulus of touch is seismonastic movement. It is shown by sensitive plants like *Mimosa*. Tropic movements are growth movements that are brought about in response to the direction of different external stimuli.

33. Find the odd man.
- (1) Fragmentation (2) Regeneration
(3) Budding in Yeast (4) Budding in Hydra

Answer (2)

Sol. Fragmentation and budding are different modes of asexual reproduction. Regeneration is a means to generate lost body parts. It is not the same as reproduction.

34. The total number of pairs of chromosomes in human beings are
- (1) 22 (2) 23
(3) 46 (4) 44

Answer (2)

Sol. Human beings have 23 pairs of chromosomes.

35. Match the column

Column A		Column B	
(i)	Darwin	(a)	Heritability of acquired characteristics
(ii)	Lamarck	(b)	Inheritance
(iii)	Mendel	(c)	Natural selection

- (1) (i) – (c), (ii) – (a), (iii) – (b)
(2) (i) – (b), (ii) – (c), (iii) – (a)
(3) (i) – (b), (ii) – (a), (iii) – (c)
(4) (i) – (a), (ii) – (c), (iii) – (b)

Answer (1)

Sol. Charles Darwin gave the theory of natural selection. Jean Baptiste Lamarck gave the theory of heritability of acquired characteristics. According to Gregor Johann Mendel inheritance of traits follow particular laws.

36. Which plant does not belong to group Thallophyta
- (1) Ulothrix (2) Spirogyra
(3) Chara (4) Funaria

Answer (4)

Sol. *Funaria* is a Bryophyte. *Ulothrix*, *Chara* and *Spirogyra* belong to division Thallophyta.

37. The excretory product in crystalline form of the plants cause itching.
- (1) Phyroid (2) Raphyids
(3) Graphyid (4) Cyanide

Answer (2)

Sol. In some plants waste is in the form of calcium oxalate crystals called Raphyids (raphides)

38. From different areas of the brain which is vision area?

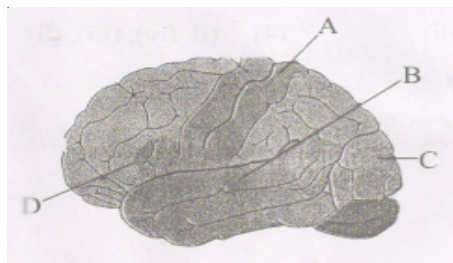

- (1) A (2) B
(3) C (4) D

Answer (3)

Sol. The part labelled as (C) is the vision area (Occipital lobe) of the brain

39. In female reproductive system ovaries secrete hormone.
- (1) testosterone (2) estrogen
(3) auxin (4) thyroxine

Answer (2)

Sol. Estrogen is female sex hormone secreted by ovaries

40. Find the odd man.
- (1) Adiantum (2) Equisetum
(3) Selaginella (4) Riccia

Answer (4)

Sol. *Riccia* is a Bryophyte. *Adiantum*, *Selaginella* and *Equisetum* are Pteridophytes

41. Select the correct chronological order from the given.
- (i) America declared war against Germany
(ii) Austria declared war against Serbia
(iii) Assassination of Austrian Prince Francis Ferdinand
(iv) Italy entered into war from England and France side
- (1) (ii), (iii), (i), (iv) (2) (iii), (ii), (iv), (i)
(3) (iv), (i), (iii), (ii) (4) (i), (iv), (iii), (ii)

Answer (2)

42. Who took lead and sacrificed the cold war?
- (1) Nikita Khrushchev
(2) Eisenhower
(3) Truman
(4) Gorbochev

Answer (4)

43. First colony established by England in America is _____.
- (1) Mary Land (2) Virginia
(3) New York (4) New Jersey

Answer (2)

44. In which continent did the first international trade revolution take place?
- (1) America (2) Africa
(3) Europe (4) Asia

Answer (3)

45. Which one of the following options is applicable to the 'Nanking Treaty' ?
- (1) Won the Hong Kong Island
(2) The business of opium was granted
(3) Christian missionaries got permission to spread their religion in China.
(4) A group of six ports was opened for the foreign traders.

Answer (1)

46. Identify the incorrect pair of the following.
- (1) Assembly – To observe the administration of UNO
(2) Security Council – Permission to new membership
(3) Economic and social committee – To protect human rights and fundamental rights
(4) Secretariat To interpret international law.

Answer (4)

47. Find the correct option of the constructive effect of imperialism.
- (1) Destruction of village autonomy
(2) Decline of values
(3) Rise of new leadership
(4) Suppression of under depended nations.

Answer (3)

48. Which policy of Linen was opposed by the extremist communist leaders?
- (1) Give land to landless farmers
(2) Allow private industry business to a limited extend
(3) To provide workers with basic needs instead of wages
(4) Domination of the working class in the government

Answer (2)

49. In which of following place parallel government was not established ?
- (1) Meerut (2) Poria
(3) Baliya (4) Midnapur

Answer (1)

50. Out of following which issue was solved peacefully by the United Nations?
- (1) The attack of Italy on Ethiopia
 - (2) Hitler's attack on Austria
 - (3) Japan's attack on Manchuria
 - (4) Italy's attack on Kaifu Island

Answer (4)

51. 'People's Party' was established by _____ .
- (1) Sultan Majid
 - (2) Kamal Pasha
 - (3) General Tojo
 - (4) Emperor Genro

Answer (2)

52. Which one of the following is not an 'Input Devices' of a computer?
- (1) Key Board
 - (2) Mouse
 - (3) Monitor
 - (4) Scanner

Answer (3)

53. The discovery of the fact that the universe is not a divine creation was made to the world by _____ .
- (1) Newton
 - (2) Holdmant
 - (3) Copernicus
 - (4) Galileo

Answer (1)

54. Which king motivated the navigators in Europe?
- (1) Nicholas
 - (2) Pancham George
 - (3) William
 - (4) Henry

Answer (4)

55. Which Asian country was involved in Africa's imperialistic policy?
- (1) Thailand
 - (2) Iraq
 - (3) Arab
 - (4) Iran

Answer (3)

56. In the given diagram which alphabet indicates the rain shadow area.

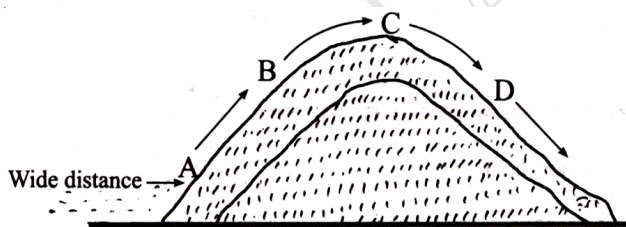

- (1) A
- (2) B
- (3) C
- (4) D

Answer (4)

57. _____ is a weight loosing raw material.
- (1) Sugar cane
 - (2) Cotton
 - (3) Wool
 - (4) Silk

Answer (1)

58. Which physical division is shown?



- (1) Southern plateau region
- (2) Western plain region
- (3) Northern mountainous region
- (4) Eastern coastal plain

Answer (3)

59. How many state capitals are connected by the Golden Quadrilateral other than Dehli?
- (1) Five
 - (2) Seven
 - (3) Six
 - (4) Eight

Answer (3)

60. Areawise which is the largest division of India?
- (1) North Indian plain region
 - (2) The Indian plateau region
 - (3) Northern mountainous region
 - (4) Ghat coastal plain region and island

Answer (1)

61. Asia's biggest Agricultural University is at _____ .
- (1) Hissar
 - (2) Ambala
 - (3) Ludhiana
 - (4) Amritsar

Answer (1)

62. In the given map which alphabet represents the Godavari delta?

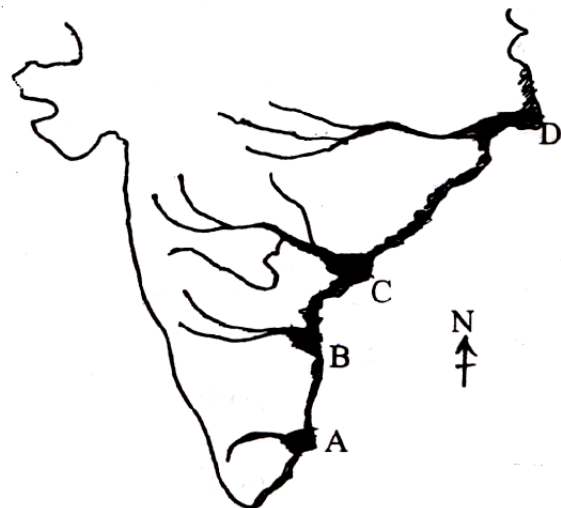

- (1) A
- (2) B
- (3) C
- (4) D

Answer (3)

63. Which of the following feature is not formed by the rivers of Ganga Plain?

- (1) Meanders (2) Ox-bow lakes
(3) Natural levees (4) 'V' shaped valley

Answer (2)

64. Which of the following is not the sub division of Deccan Plateau

- (1) Satpura–Mahadeo–Maikal ranges
(2) Maharashtra plateau
(3) Malwa plateau
(4) Karnataka plateau

Answer (3)

65. Which of the following has wrong correlation.

Type of Vehicle		Degree	Percentage
A	Public Transport	58	17.1
B	Professional vehicle	14	3.8
C	Three wheelers	14	3.8
D	Two wheelers	274	76.1

- (1) A (2) B
(3) C (4) D

Answer (3)

66. Which of the following is not the subdivision of Central Highlands?

- (1) Malwa plateau (2) Chota nagpur plateau
(3) The Vindhya ranges (4) Dandakaranya

Answer (4)

67. Find the correct pair.

- (1) North Mountainous region Chinar
(2) Rajasthan Plain Dhak
(3) Deccan Plateau Khipbush
(4) Punjab Haryana plain Sandalwood

Answer (1)

68. Find the incorrect pair.

- | State | Coastal area |
|-----------------|--------------|
| (1) Karnataka | Kalangut |
| (2) Kerala | Kovalam |
| (3) Maharashtra | Guhagar |
| (4) Goa | Kolwa |

Answer (1)

69. Proper sequence of peaks in the eastern ghats from South to North.

- (1) Nimgiri, Mahendragiri, Nallamala, Palkonda
(2) Palkonda, Nallamala, Mahendragiri, Nimgiri
(3) Nallamala, Palkonda, Mahendragiri, Nimgiri
(4) Nimgiri, Mahendragiri, Pulkonda, Nallamala

Answer (2)

70. In the middle ganga plain silk sarees are manufactured at _____.

- (1) Gorakhpur (2) Samastipur
(3) Mirzapur (4) Bhagalpur

Answer (4)

71. Who creates government and decides the powers of the regional level governments?

- (1) Legislature (2) Judiciary
(3) Executive (4) Constitution

Answer (4)

72. Kanshi Ram is 1984 founder _____ party.

- (1) Samajwadi Party
(2) Bahujan Vikas Party
(3) Bahujan Samaj Party
(4) Bharip Bahujan Maha Sangh

Answer (3)

73. In which country's electoral system does the vote of an indigenous person have more value than that of an Indian person?

- (1) Fiji (2) Estonia
(3) Mexico (4) Finland

Answer (1)

74. Due to the efforts of Eminent Social activists Anna Hazare, which right has been passed by the Indian Government?

- (1) Right to Relaxation (2) Labour Rights
(3) Right to Information (4) Human Rights

Answer (3)

75. Which one of the following is the first political work of the citizen?

- (1) to bring about people together
(2) to cast a vote
(3) to be present at meeting conducted
(4) to comment on the government

Answer (2)

76. Which of the following is not part of the consumer's Redressal Agencies'?

- (1) The taluka Forum
(2) The district Forum
(3) The State Commission
(4) The National Commission

Answer (1)

77. Who will be benefited during Inflation?

- (1) Debtors
(2) A person with steady Income
(3) A person investing in equities
(4) Creditors

Answer (1)

78. Monetary measures to control inflation is _____ .
- (1) Reduction in Public expenditure
 - (2) Increase in cash reserve ratio
 - (3) Increase in taxes
 - (4) Surplus budget

Answer (2)

79. Which of the following is extremely necessary for men?
- (1) Car
 - (2) Health
 - (3) Fan
 - (4) Furniture

Answer (2)

80. Identify the statement which relates to 'optimum population' ?
- (1) Available resources are not used enough
 - (2) Creates stress on available resources
 - (3) Population is not enough to consume resources completely
 - (4) Indicates ideal size of population of a country.

Answer (4)

81. How many numbers between 10 to 300, when divided by 4, leave remainder 3?
- (1) 71
 - (2) 72
 - (3) 73
 - (4) 74

Answer (3)

Sol. Required numbers are 11, 15, 19 299

$$a_n = 11 + (n - 1)4 = 299$$

$$\Rightarrow n = \frac{299 - 11}{4} + 1 = 73$$

82. Which of the following are the roots of the quadratic equation $x^2 + 2\sqrt{2}x - 60$?
- (1) $-3\sqrt{2}, \sqrt{2}$
 - (2) $3\sqrt{2}, -2\sqrt{2}$
 - (3) 3, 2
 - (4) 3, $2\sqrt{2}$

Answer (1)

Sol. $x^2 + 2\sqrt{2}x - 60 = 0$

$$\Rightarrow x = \frac{-2\sqrt{2} \pm \sqrt{8 - 4 \times 1 \times -60}}{2} = -3\sqrt{2}, \sqrt{2}$$

83. The expenditure incurred on different items in a family is shown in the adjacent pie diagram. If the amount of house rent is ₹10,000 then find the amount incurred on education.

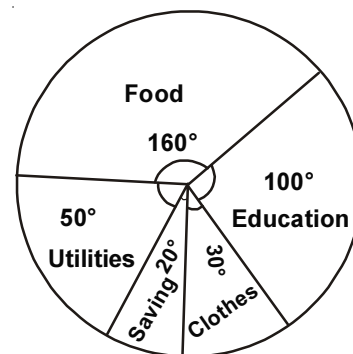

- (1) ₹20,000
- (2) ₹32,000
- (3) ₹72,000
- (4) ₹30,000

Answer (1)

Sol. $50 = \frac{10000}{x} \times 360$

$$\Rightarrow x = \frac{10000}{50} \times 360 = 72000$$

$$\therefore \text{Amount incurred on education} = \frac{x \times 360}{72000}$$

$$\Rightarrow 100 = \frac{x}{200}$$

$$\Rightarrow x = 20000$$

84. A train travels some distance at a constant speed. If the speed of the train would have increased by 15Km/hr, then it would have required 2 hours less. But if the speed of the train would have decreased by 5km/hr, then to cover the same distance it would have required 1 hour more. Find the distance covered by the train.
- (1) 120 km
 - (2) 240 km
 - (3) 360 km
 - (4) 400 km

Answer (3)

Sol. Let speed of train be v and time taken by it be t ,

$$\therefore \text{Distance travelled} = vt$$

$$\Rightarrow vt = (v + 15)(t - 2) = (v - 5)(t + 2)$$

$$\Rightarrow vt = vt - 2v + 15t - 30$$

$$\Rightarrow 15t = 2v + 30 \quad \dots(i)$$

$$\text{and } vt = vt + v - 5t - 5$$

$$\Rightarrow v - 5 = 5t \quad \dots(ii)$$

solving (i) and (ii)

$$v = 45 \text{ km/hr}$$

$$t = 8 \text{ hours}$$

$$\therefore \text{Distance} = 45 \times 8 = 360 \text{ km}$$

85. $(\sqrt[3]{3} + \sqrt[3]{2})(\sqrt[3]{9} + \sqrt[3]{4} - \sqrt[3]{6}) = ?$

- (1) 5 (2) $\sqrt[3]{5}$
(3) $\sqrt[3]{5}$ (4) $\sqrt[3]{5}$

Answer (1)

Sol. $\left(\frac{1}{3^{\frac{1}{3}}} + \frac{1}{2^{\frac{1}{3}}} \right) \left(9^{\frac{1}{3}} + 4^{\frac{1}{3}} - 6^{\frac{1}{3}} \right)$
 $= \left(\frac{1}{3^{\frac{1}{3}}} + \frac{1}{2^{\frac{1}{3}}} \right) \left(3^{\frac{2}{3}} - 3^{\frac{1}{3}} \times 2^{\frac{1}{3}} + 2^{\frac{2}{3}} \right) = \left(\frac{3}{2^{\frac{1}{3}}} + 3^{\frac{2}{3}} \right)$
 $= 3 + 2 = 5$

86. The number obtained by adding 12 to a natural number is 160 times of the multiplicative inverse of that natural number. Find the number.

- (1) 20 (2) 16
(3) 12 (4) 8

Answer (4)

Sol. $N + 12 = \frac{160}{N}$
 $\Rightarrow N^2 + 12N - 160 = 0$
 $\Rightarrow (N + 20)(N - 8) = 0$
 $\Rightarrow N = -20, 8$

87. There are 50 cards marked with the numbers 1 to 50. One card is drawn at random. What is the probability that number on the card is a prime number?

- (1) $\frac{3}{10}$ (2) $\frac{1}{5}$
(3) $\frac{1}{4}$ (4) $\frac{2}{15}$

Answer (1)

Sol. Sample space $S = \{1, 2, 3, \dots, 50\}$
 $\therefore n(S) = 50$
 Event $E = \{2, 3, 5, 7, 11, 13, 17, 19, 23, 29, 31, 37, 41, 43, 47\}$
 $\therefore n(E) = 15$
 \therefore Probability $p(E) = \frac{n(E)}{n(S)} = \frac{15}{50} = \frac{3}{10}$

88. If the polynomial $x^3 + 2x^2 - \alpha x - 12$ is divided by $(x - 4)$ the remainder is 52. Find the value of ' α '.

- (1) $\frac{11}{2}$ (2) -5
(3) 8 (4) -8

Answer (3)

Sol. Since remainder is 52 therefore according to remainder theorem,

$4^3 + 2(4)^2 - \alpha(4) - 12 = 52$
 $64 + 32 - 4\alpha - 12 = 52$
 $\therefore \alpha = 8$

89. When two simultaneous equations are solved by Cramer's Rule. We get $x = 9$ and $D = 4$; If

$D_x = \begin{vmatrix} 7 & m \\ 5 & 8 \end{vmatrix}$ then find the value of m .
 (1) -4 (2) 4
 (3) -9 (4) 9

Answer (2)

Sol. Given $D = 4, x = 9$

$\begin{vmatrix} 7 & m \\ 5 & 8 \end{vmatrix} = D_x$
 $56 - 5m = 36$
 $m = 4$

90. Following table gives the number of trees planted by the students in a school on 'Environment Day'. Observe the table and find mode of the trees planted by the students.

Number of plants	0 - 10	10 - 20	20 - 30	30 - 40	40 - 50	50 - 60
Number of students	30	42	50	80	50	40

- (1) 80 (2) 50
(3) 45 (4) 35

Answer (4)

Sol. Mode = $l + \frac{f_m - f_1}{2f_m - f_1 - f_2} \times h$
 given $f_m = 80, f_1 = 50, f_2 = 50, l = 30$
 $= 30 + \frac{80 - 50}{2 \times 80 - 50 - 50} \times 10$
 $= 30 + \frac{30}{60} \times 10$
 $= 30 + 5$
 $= 35$

91. $\frac{\cos^2 30^\circ + \cos 30^\circ \sin 30^\circ + \sin^2 30^\circ}{\cos^3 30^\circ - \sin^3 30^\circ} = ?$

- (1) 1 (2) $\sqrt{3} + 1$
(3) $\sqrt{3} - 1$ (4) $\frac{1}{\sqrt{3} - 1}$

Answer (2)

Sol. Number of discs = $\frac{\pi r_1^2 h_1}{\pi r_2^2 h_2}$

$$= \frac{\pi \times (3.3)^2 \times 40}{\pi \times (1.1)^2 \times 0.2}$$

$$= 9 \times \frac{40}{0.2}$$

$$= 9 \times 200$$

$$= 1800$$

96. In the adjacent figure $PM \perp QS$. $RN \perp QS$. Diagonals QS and PR intersect at 'O' A (ΔPMO); A (ΔRNO) = 1:4 then find.

A (ΔPQS) : A (ΔRQS)

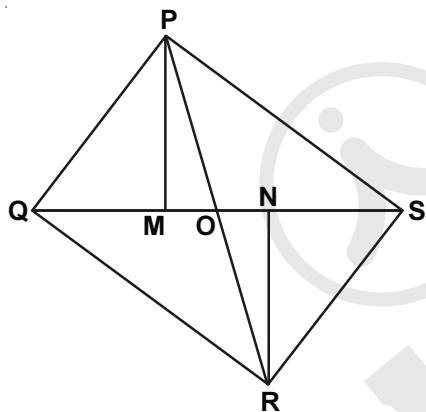

(1) $\frac{1}{16}$

(2) $\frac{1}{8}$

(3) $\frac{1}{4}$

(4) $\frac{1}{2}$

Answer (4)

Sol. $\frac{PM^2}{PN^2} = \frac{1}{4} \Rightarrow \frac{PM}{PN} = \frac{1}{2}$

$$\frac{\text{ar}(\Delta PQS)}{\text{ar}(\Delta RQS)} = \frac{\frac{1}{2} \times QS \times PM}{\frac{1}{2} \times QS \times PN} = \frac{PM}{PN} = \frac{1}{2}$$

97. The longest side of a triangle is 20 cm. and other side is 10 cm. The area of the triangle is 80 cm². Find the length of the remaining side of the triangle.

(1) $2\sqrt{65}$

(2) $5\sqrt{10}$

(3) $10\sqrt{3}$

(4) 15

Answer (1)

Sol. Area of triangle = 80 cm²

$$= 80 = \sqrt{\left(\frac{x+30}{2}\right)\left(\frac{x-10}{2}\right)\left(\frac{x+10}{2}\right)\left(\frac{30-x}{2}\right)}$$

$$-80^2 = \frac{(x^2 - 100)(900 - x^2)}{4 \times 4}$$

$$-80^2 \times 16 = x^4 - 1000x^2 + 90000$$

$$x^4 - 1000x^2 + 192400 = 0$$

$$x = 2\sqrt{65}$$

98. In the adjoining figure 'O' is the center of the circle

$AB = BC$, $m\angle AOD = x$ and $m\angle ACB = y$ then find $\frac{x}{y}$

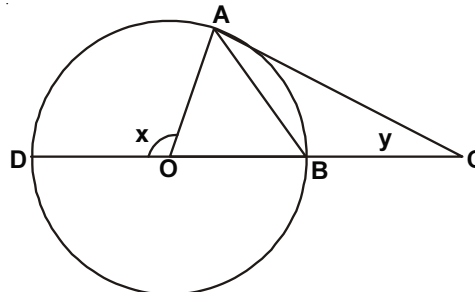

(1) $\frac{1}{2}$

(2) 2

(3) 4

(4) $\frac{1}{4}$

Answer (3)

Sol. In ΔAOB , $\angle ABO = \angle BAO = z$

$$2z + 180 - x = 180 \Rightarrow z = \frac{x}{2}$$

ΔABC , $\angle BAC = \angle BCA = y$

$$y + 180 - \frac{x}{2} + y = 180 \Rightarrow 2y = \frac{x}{2}$$

$$\Rightarrow \frac{x}{y} = 4$$

99. In the adjoining figure if $AB = 16$ and $CD = 40$ then find the ratio of A (ΔOCD): A (ΔOAB)

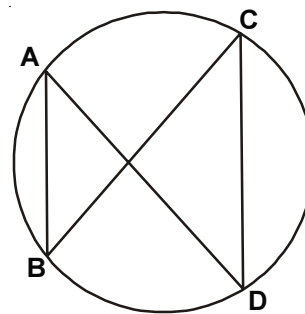

(1) $\frac{5}{2}$

(2) $\frac{2}{9}$

(3) $\frac{25}{4}$

(4) $\frac{4}{25}$

Answer (3)

Sol.

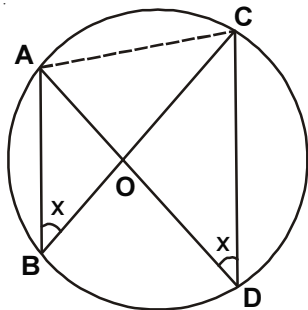

$\angle AOB = \angle COD$ (vertically opposite angles)

$\angle ABO = \angle CDO$ (angles in same segment)

$\Rightarrow \Delta AOB \sim \Delta COD$ (by AA)

$$\therefore \frac{\text{ar}(\Delta COD)}{\text{ar}(\Delta AOB)} = \frac{CD^2}{AB^2} = \left(\frac{40}{16}\right)^2 = \left(\frac{5}{2}\right)^2 = \frac{25}{16}$$

100. In the adjoining figure $\square ABCD$ and $\square PBCQ$ are parallelogram $BC = 12$ cm $PR = 8$ cm. Find A (ΔPSB).

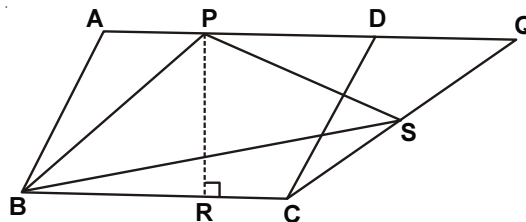

(1) 96 cm^2

(2) 72 cm^2

(3) 48 cm^2

(4) 36 cm^2

Answer (3)

Sol. $\text{ar} (ABCD) = \text{ar} (PQCB)$

$$\text{ar} (\Delta PSB) = \frac{1}{2} \text{ar} (PQCB)$$

and, $\text{ar} (PQCB) = 12 \times 8 = 96 \text{ cm}^2$

$$\therefore \text{ar} (\Delta PSB) = \frac{1}{2} \text{ar} (PQCB) = \frac{1}{2} \times 96 = 48 \text{ cm}^2$$

