

**GENERAL SCIENCE, Paper - I**

(Physical Science)

(English version)

Parts A and B

Time : 2 hrs. 45 min]

[Maximum Marks : 40

**Instructions :**

1. This paper contains **Part-A** and **Part-B**.
2. Answer the questions under **Part-A** on separate answer book. Write the answers to the questions under **Part-B** on the question paper itself and attach it to the answer book of **Part-A**.
3. Answer **all** the questions. Internal choice is given to the questions under Section-III.
4. In the duration of 2.45 hours, 15 minutes of time is allotted to read the question paper.

**Part - A**

Time : 2 hours

Marks : 30

**Instructions :**

1. **Part-A** comprises **THREE** Sections I, II and III.
2. **All** the questions are **compulsory**.
3. There is no over all choice. However, there is an internal choice to the questions under Section-III.

**SECTION - I**

**NOTE :** (i) Answer **all** the questions.

4×1=4

(ii) Answer each question in 1 or 2 sentences.

(iii) Each question carries **ONE** mark.

1. We use P.V.C. pipes for water supply instead of metal pipes. Why ?

19E(A)/New

**NA**

P.T.O.

2. Optical Fibre Cable (OFC) are oftenly used in tele-communications. What is the working principle behind the OFC ?

3.

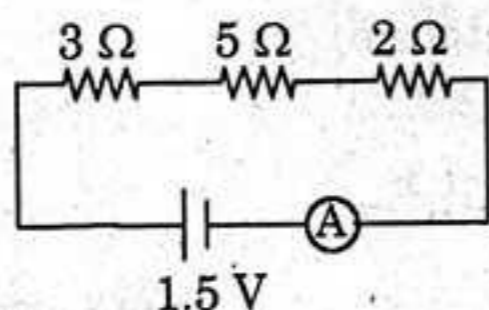

Find the quantity of current in the above circuit.

4. Roasting and Calcination are the methods to extract crude metals from ores. What is the difference between Roasting and Calcination?

### SECTION - II

**NOTE :** (i) Answer **all** the questions.

$5 \times 2 = 10$

(ii) Answer each question in 4 or 5 sentences.

(iii) Each question carries **TWO** marks.

5. Balance the chemical equation by indicating the physical states of the substances for the following reaction :

Barium chloride and Sodium sulphate aqueous solutions react to give Barium sulphate precipitate and aqueous Sodium chloride.

6. A convex lens is made of five different materials as shown in the figure. How many images does it form ? Why ?



7. The electronic configuration of Sodium is  $1s^2 2s^2 2p^6 3s^1$ . What information that it gives ?



8. We can save the household wiring and devices by using fuses. Write any four points by appreciating the role of fuse.
9. Potassium, Sodium, Magnesium are high reactive metals and occur as chlorides in nature. Suggest and explain the suitable method for the extraction of the above metals from their ores.

### SECTION - III

- NOTE :** (i) Answer **all** the questions. 4×4=16  
 (ii) Answer each question in 8-10 sentences.  
 (iii) There is internal choice for each question.  
 (iv) Only one option from each question is to be attempted.  
 (v) Each question carries **FOUR** marks.

10. Sudheer wants to verify the laws of reflection. What apparatus he requires to prove them? State the laws of reflection and write the experimentation process he follows.

**OR**

How can you verify with experiment "The magnetic field lines are closed loops" ?

11. Elements of one short period of the Periodic Table are given below in the order from left to right.

Li, Be, B, C, N, F, Ne

*Answer the following.*

- (i) To which period, do these elements belong ?  
 (ii) One element of this period is missing. Which is the missing element and where it should be placed ?  
 (iii) Which of the above elements belong to the family of halogens ? What is its electro-negativity value ?  
 (iv) How does the metallic character varies in the Period ?

**OR**

[4]

**OR**

The arrangement of electrons in different shells of atoms of 18th Group elements is given in the table.

Element	Z	Electronic configuration			
		K	L	M	N
Helium (He)	2	2			
Neon (Ne)	10	2	8		
Argon (Ar)	18	2	8	8	
Krypton (Kr)	36	2	8	18	8

*Answer the questions :*

- (i) What is the general electronic configuration of the above elements except He ?
- (ii) What is the valency of Argon ?
- (iii) Write Lewis dot structure of Neon.
- (iv) Why the above elements do not take part in bond formation ?

12. Write the factors that effect the process of evaporation. Explain with suitable examples.

**OR**

Alkanes are considered as Paraffins. So, they undergo substitution reactions but not addition reactions. Explain with suitable example.

13. Revathi is a front bench student. She is unable to draw the picture drawn on the black-board. She got permission from the teacher and sat in the back row. What could be the defect that Revathi is suffering from? Draw the diagram, which shows the correction of the above defect ?

**OR**

Draw a neat diagram showing a base solution in water conducts electricity. Why the solution of sugar/glucose in water do not conduct electricity ?



19E(B)

**GENERAL SCIENCE, Paper - I**

*(Physical Science)*

*(English version)*

**Parts A and B**

**Time : 2 hrs. 45 min.]**

**[Maximum Marks : 40**

**Instructions :**

1. Answer all the questions.
2. Each question carries  $\frac{1}{2}$  mark.
3. Marks will **not** be awarded in any case of over-writing, rewritten or erased answers.
4. Write the CAPITAL LETTER (A, B, C, D) showing the correct answer for the following questions in the brackets provided against them.

**Part - B**

**Time : 30 min.**

**Marks : 10**

**SECTION - IV**

**NOTE :** (i) Answer **all** the questions.

(ii) Each question carries  $\frac{1}{2}$  mark.

$20 \times \frac{1}{2} = 10$

14.  $\text{BaCl}_2 + \text{Na}_2\text{SO}_4 \rightarrow \text{BaSO}_4 + 2 \text{NaCl}$  represents .....

[ ]

- (i) Decomposition reaction
  - (ii) Displacement reaction
  - (iii) Precipitation reaction
  - (iv) Double displacement reaction
- (A) Only (i) (B) (ii) & (iii)  
(C) (iii) & (iv) (D) Only (iv)

15. A test tube immersed at a certain angle in a tumbler of water to have a mirror surface for a certain viewing position. It is due to .....

[ ]

(Note : Water should not enter into the test tube).

- (A) Reflection (B) Refraction  
(C) Total internal reflection (D) Scattering

19E(B)/New

**NA**

**P.T.O.**

16. In torches, search-lights and head-lights of vehicles, the bulb is placed ..... [ ]  
 (A) between the pole and the focus of the reflector.  
 (B) at the focus of the reflector.  
 (C) at the centre of curvature of the reflector.  
 (D) between the focus and the centre of curvature of the reflector.
17. The unit of refractive index is ..... [ ]  
 (A) Centimeter (B) Diapter  
 (C) Degree (D) No units
18. Match the following : [ ]  
 (i) Scattering P. Eye defect  
 (ii) Dispersion Q. VIBGYOR  
 (iii) Power of lens R. Retina  
 (iv) Cones and rods S. Colour of the sky.  
 (A) (i) - S, (ii) - Q, (iii) - R, (iv) - P  
 (B) (i) - Q, (ii) - S, (iii) - P, (iv) - R  
 (C) (i) - S, (ii) - Q, (iii) - P, (iv) - R  
 (D) (i) - Q, (ii) - S, (iii) - R, (iv) - P
19. A real and inverted image of the same size is formed by a convex lens, when the object is placed ..... [ ]  
 (A) at F  
 (B) at C  
 (C) between F & C.  
 (D) between F and Optical centre.
20. The angle of vision of a normal human being is about ..... [ ]  
 (A)  $160^\circ$  (B)  $60^\circ$   
 (C)  $6^\circ$  (D)  $16^\circ$
21. Which of the following, do not obey the Octet rule ? [ ]  
 (A)  $O_2$  (B)  $F_2$   
 (C)  $BCl_3$  (D)  $N_2$





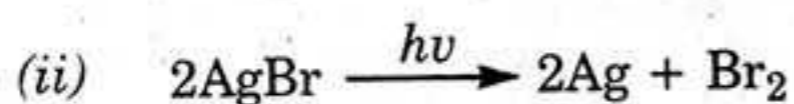
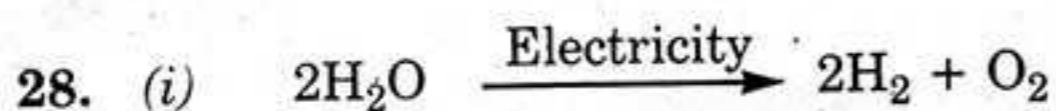

The above reactions are examples for ..... [ ]

- (A) Chemical combination. (B) Chemical decomposition.  
(C) Chemical displacement. (D) Double displacement.

29. The refractive index values of different material are given under : [ ]

Material	Refractive index
Crown glass	1.52
Ruby	1.71
Ice	1.31
Sapphire	1.77

Imagine, in which of the above, the velocity of light is greater ?

- (A) Sapphire (B) Crown glass  
(C) Ice (D) Ruby

30. The electro-magnetic spectrum consists of both visible light and invisible light like X-rays,  $\gamma$ -rays, I.R., U.V. rays, microwaves and radio waves.

Among these, the radiation with large wave-length is ..... [ ]

- (A)  $\gamma$ -rays (B) U.V. rays  
(C) I.R. (D) Radio-waves.

31. Na, Mg, Zn, Fe, Ag and Au are the few metals of reactivity series of metals. Ramu : Fe is a moderate reactive metal.

Raju : Mg is not a moderate reactive metal. [ ]

- (A) Ramu correct; Raju incorrect. (B) Ramu incorrect; Raju correct.  
(C) Both Ramu & Raju correct. (D) Both Ramu & Raju incorrect.

32. The doctor checked the body temperature of a 10th class student and said his body temperature is 310K. The body temperature of that boy in celsius scale is ..... [ ]

- (A) 273°C (B) 30°C  
(C) 98.4°C (D) 37°C

33. The Carboxylic acid which is used as a preservative in preparation of pickles is ..... [ ]

- (A) Methanoic acid (B) Ethanoic acid  
(C) Propanoic acid (D) Butanoic acid