

**PART 02 — BASIC ENGINEERING AND SCIENCE**

(Common to all candidates)

31. Free body diagram of point C of the Derrick shown below is

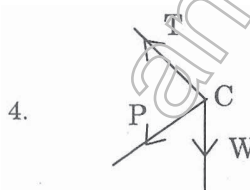
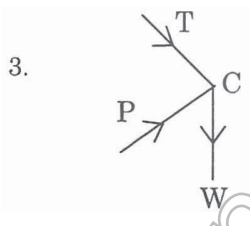
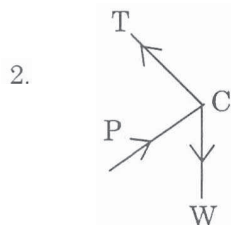
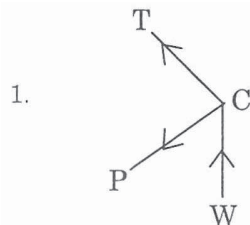
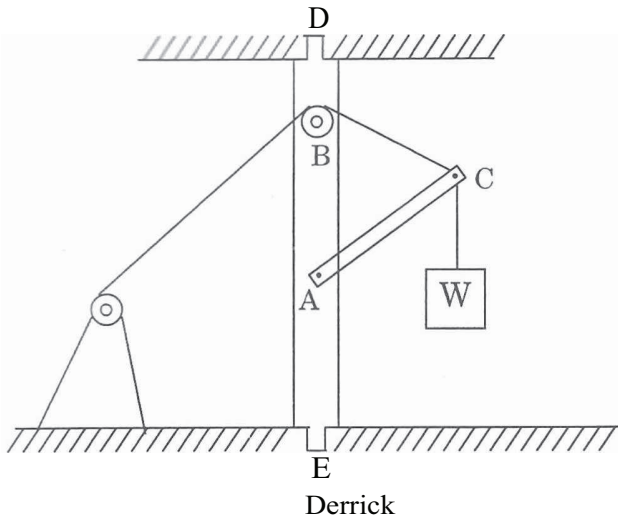

32. A 200 kg block is in contact with a plane inclined at  $30^\circ$  to the horizontal. A force  $P$ , parallel to and acting up the plane, is applied to the body. If the coefficient of static friction is 0.20, the value of  $P$  to just cause motion up the plane is

1. 1.35 kg
2. 13.5 kg
3. 135 kg
4. 530 kg

33. Find the moment of the Force 'F' acting along the edge 'CB' of a cube of edge 1 m about the centre of the base of the cube OCDE, shown below.

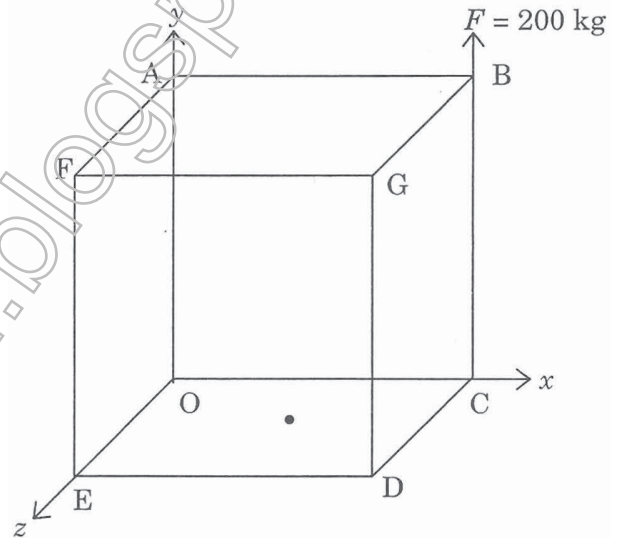

1. 4140 Nm
2. 144 Nm
3. 1414 Nm
4. 4144 Nm

34. The motion of a particle is given by  $a = 6v^{1/2}$  where  $a$  is in  $\text{m/sec}^2$  and  $v$  is in  $\text{m/sec}$ , when  $t = 0, v = 0$ . Find the relation between  $v$  and  $t$

1.  $v = 9t^2$
2.  $t = v/4$
3.  $v^2 = 9t$
4.  $t = 9v^2$

35. A particle of mass 10 kg is moving along the circumference of a circle of radius 10 m. If the tangential velocity of the particle is 5 m/sec, then the kinetic energy gained by the body in 10 rotations is
1. 500 J
  2. 0 J
  3. 400 J
  4. 1250 J
36. The packing factor for  $\gamma$ -iron is
1. 0.34
  2. 0.52
  3. 0.68
  4. 0.74
37. Which one among the following is a thermoset material?
1. Rubber
  2. Nylon
  3. Urea formaldehyde
  4. Teflon
38. Which metal among the following would not undergo corrosion?
1. Copper
  2. Gold
  3. Silver
  4. Iron
39. Domain structure is exhibited by
1. ferromagnets
  2. paramagnets
  3. diamagnets
  4. both dia and paramagnets
40. At absolute zero, the probability of occupation of energy levels below the Fermi energy level, by electrons, is
1. 1
  2.  $1/2$
  3.  $1/3$
  4.  $1/4$
41. A water column of volume 6.5 litres is subjected to a direct pressure of  $1.8 \times 10^6 \text{ N/m}^2$ . Determine the change in volume of water column if the bulk modulus of water is taken as  $2 \times 10^9 \text{ N/mm}^2$
1.  $5.85 \times 10^{-6} \text{ m}^3$
  2.  $58.5 \times 10^{-3} \text{ m}^3$
  3.  $2.05 \times 10^{-4} \text{ m}^3$
  4.  $1.85 \times 10^{-5} \text{ m}^3$
42. Density index of a material is
1. greater than one
  2. less than one
  3. equal to one
  4. indeterminate
43. The constituent of cement that imparts quick setting quality to cement is
1. Magnesia
  2. Iron oxide
  3. Alumina
  4. Silica
44. A surveyor's mark cut on a stone or rock or any reference point to indicate a level in a levelling survey is called
1. reduced level
  2. change point
  3. levelling mark
  4. bench mark
45. According to the United States Bureau of soil classification, the soil is designated as 'coarse clay' if the particle size varies from
1. 0.0001 mm to 0.002 mm
  2. 0.02 mm to 0.06 mm
  3. 0.2 mm to 0.6 mm
  4. 0.6 mm to 2 mm

46. Two capacitors A and B are placed in series. Capacitors  $C_A = 100 \mu\text{F}$  and  $C_B = 50 \mu\text{F}$ . The maximum energy stored in the circuit when 240 V, 50 Hz supply is applied to the circuit is

1. 19.2 J
2. 1.92 J
3. 192 J
4. 12.9 J

47. With reference to the network shown below, by applying Thevenin's theorem, find the equivalent voltage of the network when viewed from the terminals CD

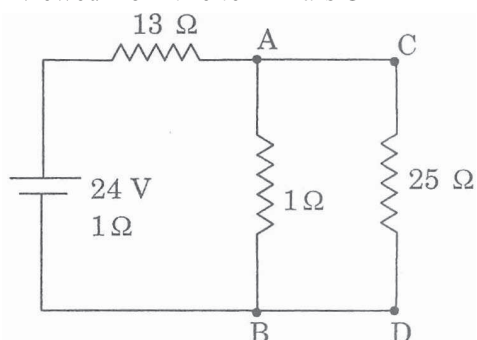

1. 12 V
2. 6 V
3. 18 V
4. 21.5 V

48. "In a Delta/Star transformation of meshes, it must be remembered that the resistance of each arm of the star is given by the \_\_\_\_\_ of the resistance of the two delta sides that meet at its ends divided by the \_\_\_\_\_ of the three delta resistances."

1. product, product
2. sum, product
3. product, sum
4. sum, sum

49. An alternating voltage of  $(8 + j6)V$  is applied to a series a.c. circuit and the current passing is  $(2 + j5)A$ . The impedance of the circuit is

1.  $8.6 \Omega$
2.  $18.6 \Omega$
3.  $1.68 \Omega$
4.  $1.86 \Omega$

50. A moving coil ammeter is wound with 40 turns and gives full scale deflection with 5 A. How many turns would be required on the same bobbin to give full scale deflection with 20 A?

1. 10
2. 40
3. 12
4. 21

51. The percentage of carbon in eutectoid steel is

1. 0.8
2. 0.4
3. 0.02
4. 1.2

52. Which one of the following is not using electron as a source of energy?

1. Solar cell
2. MHD generator
3. Fuel cell
4. Atomic power plant

53. Temporary metal forming process is

1. Welding
2. Brazing
3. Mechanical bonding
4. Soldering

54. Under isobaric conditions, the Gibb's phase rule takes the form

1.  $F = C - P + 2$
2.  $F = C - P + 1$
3.  $F = C - P + 3$
4.  $F = C - P$

55. Which one of the following metals is more ductile?

1. Copper
2. Silver
3. Gold
4. Nickel

56. Express the following switching circuit in binary logic notation

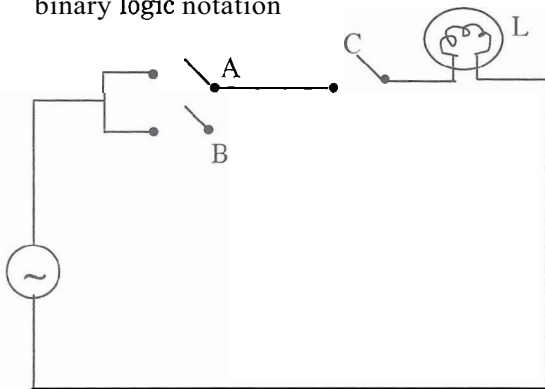

1.  $L = (AC + BC)$
2.  $L = (A + B) \cdot C$
3.  $L = (A + B) + C$
4.  $L = A + (B + C)$

57. Applying DeMorgan's theorem find the equivalent of  $(x + yz)'$

1.  $(x' + y') \cdot z'$
2.  $(x' + z') \cdot y'$
3.  $(y' + x') + z'$
4.  $x' \cdot (y' + z')$

58. LAN stands for

1. Local Access Network
2. Local Area Network
3. Link Access Network
4. Listed Area Network

59. An electronic semiconductor device that is fabricated with permanently stored information, which cannot be erased is called

1. Random Access Memory
2. Read Only Memory
3. Memory Data Register
4. Memory Address Register

60. Which of the following are the system directories in Unix?

1. /bin, /etc, /lib, /tmp
2. /local, /usr, /dev, /bin
3. /bash, /etc, /lib, /tmp
4. /sys, /dev, /bin, /usr

61. If  $\theta$  is the angle between the vectors  $\vec{a}$  and  $\vec{b}$  such that  $|\vec{a} \times \vec{b}| = \sqrt{10}$  and  $\vec{a} \cdot \vec{b} = \sqrt{30}$ , then the value of  $\cos \theta$  is

1.  $1/3$
2.  $1/2$
3.  $\frac{2}{\sqrt{3}}$
4.  $\frac{\sqrt{3}}{2}$

62. If  $a = \sqrt{2}i$ , then which of the following is true?

1.  $a = (\pm\sqrt{2})i$
2.  $a + i = 1$
3.  $a - i = 1$
4.  $a = (-\&)i$

63. The value of the determinant given below is

$$A = \begin{vmatrix} \alpha^2 & \alpha^3 & \alpha^4 \\ \alpha^3 & \alpha^4 & \alpha^5 \\ \alpha^4 & \alpha^6 & \alpha^7 \end{vmatrix}$$

1.  $\alpha^9$
2.  $\alpha^{13}$
3.  $2\alpha^2$
4.  $0$

64. Which of the following points lies on the circle with centre  $(3, -2)$  and radius 3 units?

1.  $(3, 1)$
2.  $(1, 3)$
3.  $(-1, 3)$
4.  $(-3, 1)$

65. A die and a coin are thrown together. The probability of obtaining a prime number on the die and tail on the coin is

1.  $1/2$
2.  $(1/2)^2$
3.  $(1/2)^3$
4.  $(1/2)^4$

- Two coils connected in series have resistances of  $600\ \Omega$  and  $300\ \Omega$  and temperature coefficient of  $0.001$  and  $0.004$  respectively at  $20^\circ\text{C}$ . The resultant of the combination at  $20^\circ\text{C}$  is
- $954\ \Omega$
  - $549\ \Omega$
  - $1094\ \Omega$
  - $850\ \Omega$
67. A boat is at rest under the action of three forces, two of which are  $F_1 = 4i$  and  $F_2 = 6j$ . Then the  $z$ -component of the third force is
- $-4$  units
  - $-6$  units
  - $0$  units
  - $-10$  units
68. A body that absorbs all the radiation falling on it is called a
- good absorber
  - perfect black body
  - black body
  - good emitter
69. Quantum nature of light is not supported by the phenomenon of
- Compton effect
  - Photoelectric emission
  - Emission or absorption spectrum
  - Diffraction of light
70. Current carriers in an electrolyte are
- electrons and negative ions
  - electrons and positive ions
  - positive and negative ions
  - electrons and ions
71. A real gas would approach the behaviour of an ideal gas at
- low temperature and high pressure
  - low temperature and low pressure
  - high temperature and low pressure
  - high temperature and high pressure
72. Boron trifluoride ( $\text{BF}_3$ ) will act as
- a base
  - an acid
  - both as a base and an acid
  - neither a base nor an acid
73. An electric current is passed through an aqueous solution given below. Which one shall deposit?
- Urea
  - Silver Nitrate
  - Ethyl alcohol
  - Glucose
74. The element of highest electronegativity is
- Flourine
  - Chlorine
  - Oxygen
  - Caesium
75. Which one of the following involves a polar bond?
- $\text{Cl} - \text{Cl}$
  - $\text{O} - \text{O}$
  - $\text{Br} - \text{Br}$
  - $\text{H} - \text{Cl}$