

Pre-Board Examination 1- 2019-20

Sub: SCIENCE (086)

Class: X

Marks: 80

Date: -

Time: 3 hrs.

General Instructions:

This paper consists of 9 printed pages and there are 30 questions in all.

1. The question paper comprises three sections – A, B and C. Attempt all the sections.
2. All questions are compulsory.
3. Internal choice is given in each section.
4. All questions in Section A are one-mark questions comprising MCQ, VSA type and assertion-reason type questions. They are to be answered in one word or in one sentence.
5. All questions in Section B are three-mark, short-answer type questions. These are to be answered in about 50 - 60 words each.
6. All questions in Section C are five-mark, long-answer type questions. These are to be answered in about 80 – 90 words each.

SECTION A

1. Select saturated hydrocarbons from the following: 1
 C_3H_6 , C_4H_{10} , C_3H_4 , C_6H_{14} , C_5H_{10}
2. **Answer question numbers 2.1–2.4 on the basis of your understanding of the following paragraph and the related studied concepts.**

The sight of sunrise and sunset is the prettiest. Isn't it? But if you notice carefully, you'll notice the sun appears red during sunrise and sunset. Do you know, why? Well, it's because of 'Scattering of Light'. But what does one mean when they say scattering of light? The molecules of air and other fine particles in the atmosphere have size smaller than the wavelength of visible light. These are more effective in scattering light of shorter wavelengths at the blue end than light of longer wavelengths at the red end. The red

light has a wavelength about 1.8 times greater than blue light. Thus, when sunlight passes through the atmosphere, the fine particles in air scatter the blue colour (shorter wavelengths) more strongly than red. The scattered blue light enters our eyes. If the earth had no atmosphere, there would not have been any scattering. Then, the sky would have looked dark.

Why do stars appear higher than they actually are? Does this have something to do with the scattering of light? Well, the answer to this is 'No'. Stars appear higher than they are because of 'Atmospheric Refraction'.

- 2.1 Explain giving reason why the sky appears blue to an observer from the surface of the earth? 1
- 2.2 Why do stars twinkle? 1
- 2.3 'Danger' signal lights are red in colour. Give reason. 1
- 2.4 What will be the colour of sky for an astronaut staying in the international space station orbiting the earth? Justify your answer giving reason. 1
3. **Question numbers 3.1-3.4 are based on the two tables given below. Study these tables and answer the questions that follows:**

Table A

Normal Hemoglobin Count Ranges Widely Accepted by Physicians.	
Birth	13.5 to 24.0 g/dl (mean 16.5 g/dl)
<1 month:	10.0 to 20.0 g/dl (mean 13.9 g/dl)
1 to 2 months:	10.0 to 18.0 g/dl (mean 11.2 g/dl)
2 to 6 months:	9.5 to 14.0 g/dl (mean 12.6 g/dl)
0.5 to 2 yrs:	10.5 to 13.5 g/dl (mean 12.0 g/dl)
2 to 6 yrs:	11.5 to 13.5 g/dl (mean 12.5 g/dl)
6 to 12 yrs:	11.5 to 15.5 g/dl (mean 13.5 g/dl)

Table B

Females	
Age 12 to 18 yrs:	12.0 to 16.0 g/dl (mean 14.0 g/dl)
Age > 18 yrs:	12.1 to 15.1 g/dl (mean 14.0 g/dl)
Male	
Age 12 to 18 yrs:	13.0 to 16.0 g/dl (mean 14.5 g/dl)
Age > 18 yrs:	13.6 to 17.7 g/dl (mean 15.5 g/dl)

- 3.1 Infer the disease which can be diagnosed from the given data in a girl studying in high school and has hemoglobin 8 g/dl. 1
- 3.2 A student of class 10, likes to eat a diet rich in carbohydrates, junk food has been found anaemic. Hence, he finds it difficult to concentrate on his studies. To help him out of this situation, name any four foods that he must include in his diet. 1
- 3.3 A person of 18 years has pale skin, feels dizzy after mild exercise and feels very tired. He got his Hb levels tested. His tests may have shown haemoglobin levels- 1
- (a) $14 > \text{g/dl}$ (b) $< 11 \text{ g/dl}$
(c) $> 16 \text{ g/dl}$ (d) $< 17 \text{ g/dl}$
- 3.4 Role of haemoglobin is not to 1
- (a) Attach oxygen entering the lungs
(b) Serve as respiratory pigment
(c) Gives red colour to the blood
(d) To transport lymph 1
4. Name the nuclear process that is responsible for energy release on (a) sun and (b) nuclear reactor.
5. A current flow through a horizontal power line from east to west direction. What is the direction of magnetic field at a point directly below it? 1
6. In a circuit if two resistors of 5Ω and 10Ω are connected in series, Find the ratio of current passing through the two resistors. 1
7. Why are thermal power plants set up near coal or oil fields? 1
8. Write the number of vertical columns in the modern periodic 1

- table. What are these columns called?
9. Ethanoic acid was added to sodium bicarbonate solution and the gas evolved was tested with a burning splinter Which one of the following four observations is correct? 1
- (i) The gas burns with a pop sound and the flame gets extinguished.
 - (ii) The gas does not burn, but the splinter burns with a pop sound.
 - (iii) The flame extinguishes and the gas does not burn.
 - (iv) The gas burns with a blue flame and the splinter burns brightly.
10. If pH of a solution is 13, it means that it is 1
- (i) weakly acidic
 - (ii) strongly acidic
 - (iii) weakly basic
 - (iv) strongly basic
11. Identify the group which is not a Dobereiner triad 1
- (i) Li, Na, K
 - (ii) Be, Mg, Cr
 - (iii) Ca, Sr, Ba
 - (iv) Cl, Br, I

OR

Across a period metallic character -----

- (i) increases
- (ii) decreases
- (iii) remains the same
- (iv) none of these

For question numbers 12 and 13, two statements are given-one labelled Assertion (A) and the other labelled Reason (R). Select the correct answer to these questions from the codes (a), (b), (c) and (d) as given below:

- (a) Both the assertion and reason are correct, and the reason is the correct explanation of the Assertion.
- (b) Assertion and reason are correct, but the reason is not the correct explanation of the assertion.
- (c) Assertion is true, but reason is false.
- (d) Assertion is false, but reason is true.

12. **Assertion (A):** Copper reacts with silver nitrate solution. 1
Reason(R): Copper is placed higher in the metal activity series than silver. Thus, it can displace silver from silver nitrate solution
13. **Assertion (A):** Acquired traits cannot be passed on from one generation to next generation. 1
Reason(R): Inaccuracy during DNA copying of acquired trait is minimum.
14. Wild cabbage has evolved into new varieties like cabbage, 1
broccoli and cauliflower by
a) Genetic drift
b) Natural selection
c) Reproductive isolation
d) Artificial selection

SECTION B

15. For the current carrying solenoid as shown below, draw magnetic field lines. 3
Out of the three points A, B and C at which point the field strength is maximum, and at which point it is minimum?

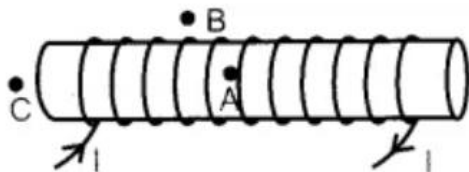

16. (i) Draw a diagram to show a parallel combination of three resistors. 3
(ii) Find the number of 176Ω resistor connected in parallel to make a combination required to carry 5 A current from a source of 220 V.
17. Sudha finds out that the sharp image of the windowpane of her science laboratory is formed at a distance of 15 cm from the lens. She now tries to focus the building visible to her outside the window instead of the windowpane without disturbing the lens. In which direction will she move the screen to obtain a sharp image of the building? What is the approximate focal length of this lens? 3

OR

An object placed on a meter scale at 8 cm mark was focused on a white screen placed at 92 cm mark, using a converging lens placed on the scale at 50 cm mark.

- (i) Find the focal length of converging lens.
- (ii) Find the position of image formed if the object is shifted towards the lens at a position of 29.0 cm.
- (iii) State the nature of image formed if the object is further shifted towards the lens.

18. 2 g of ferrous sulphate crystals were heated in a hard glass test tube and observations recorded. 3

(i) What type of odour is observed on heating ferrous sulphate crystals?

(ii) Write balanced chemical equation for the above reaction.

(iii) What type of reaction is taking place?

19. For making cake, baking powder is taken. If at home your mother uses baking soda instead of baking powder in cake 3

(i) How will it affect the taste of the cake and Why?

(ii) How can baking soda be converted into baking powder?

(iii) What is the role of tartaric acid in baking powder?

OR

A compound which is prepared from gypsum has the property of hardening when mixed with a proper quantity of water.

(i) Identify the compound.

(ii) Write the chemical equation for its preparation.

(iii) For what purpose is it used in hospitals?

20. An element X (atomic number 17) reacts with an element Y (atomic number 20) to form a divalent halide. 3

(i) Where in the periodic table are elements X and Y placed?

(Mention group & period both)

(ii) Classify X and Y as metal(s), non-metal(s) or metalloid(s).

(iii) What will be the nature of the oxide of element Y? Identify the nature of bonding in the compound formed.

21. Mention three important features of fossils which help in the study of evolution. 3

22. (i) Create a terrestrial food chain depicting four trophic levels. 3

(ii) Why do we not find food chains of more than four trophic levels in nature?

OR

How will you create an artificial aquatic ecosystem, which is

- self-sustainable?
23. How does Auxin promote the growth of a tendril around a support? 3
24. What is a dam? Write two main advantages and ill-effects of constructing a big dam. 3

SECTION C

25. (a) Write balanced chemical equations for the following reactions:
- (i) Calcium metal reacts with water 1
- (ii) Cinnabar is heated in the presence of air 1
- (iii) Manganese dioxide is heated with Aluminium powder 1
- (b) What are alloys? 1
- (c) What are the constituents of Solder? 1

OR

- (a) Write two chemical equations to show that Aluminum oxide is an amphoteric oxide. 2
- (b) Compound X and Aluminum are used to join railway tracks
- (i) Identify the compound X. 1
- (ii) Name the reaction. 1
- (iii) Write balanced chemical equation for the above reaction. 1
26. (a) How would you bring about the following conversions? Write the reaction and name the process involved.
- (i) Ethanol to Ethene 1
- (ii) Ethanol to Ethanoic acid 1
- (b) An organic compound A is an essential constituent of wine and beer. Oxidation of A yields an organic compound B which is present in vinegar. 1
- (i) Name the compounds A and B
- (ii) What happens when A and B react in the presence of an acid catalyst. 1
- (iii) Write balanced chemical equation for the reaction. 1
27. a) i) What is Excretion? Draw a well labeled diagram of excretory system in human. 2

- ii) Name the functional unit of Kidney. 1
- b) How do plants excrete their waste? 2
28. a. Why does bread mould grow profusely on a moist slice of bread rather than on a dry slice of bread? 2
- b. Name the organism in which binary fission occurs in a definite orientation than others. Draw different stages of binary fission shown by this organism. 2
- c. Complete the diagram D and E by indicating the regenerated regions in Planaria. 1

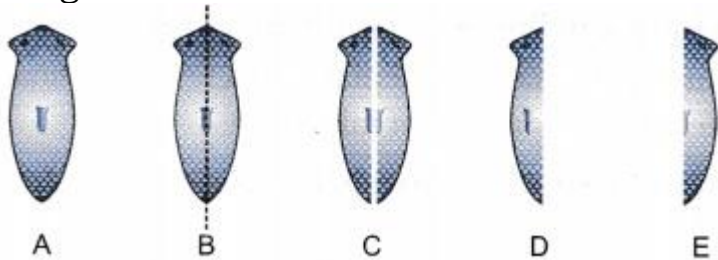

OR

- a) Explain the role of placenta in the development of human embryo. 2
- b) Give example of two bacterial and two viral sexually transmitted diseases. Name the most effective contraceptive which prevents spread of such diseases. 3
29. (a) State the function of fuse in the domestic electric circuit. Write its most important characteristic, Name the material generally used to prepare a good fuse wire. 3
- (b) An electric oven of 2KW power rating is operated in a domestic electric circuit (220 V) that has a current rating 5A. 2
- (i) What is the current drawn?
- (ii) What will happen to the fuse wire? Justify your answer.

OR

Find out the following in the electric circuit given in the figure.

- (i) Effective resistance of two 8Ω resistors in the combination. 5
- (ii) Current flowing through 4Ω resistor.
- (iii) Potential difference across 4Ω resistor.

- (iv) Power dissipated in 4Ω resistor.
- (v) Difference in ammeter readings, if any.

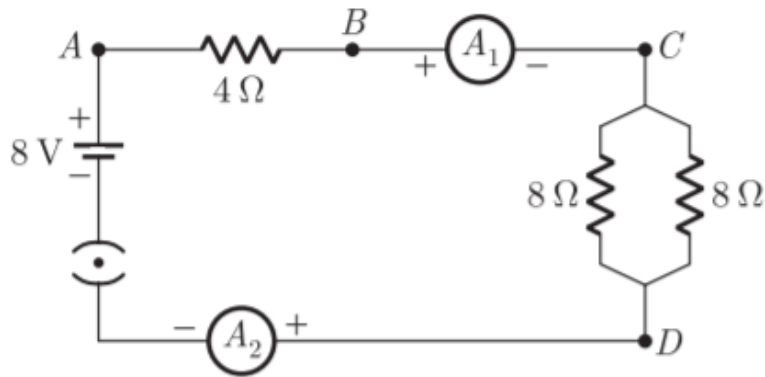

30. Study the given diagram and answer the questions below:

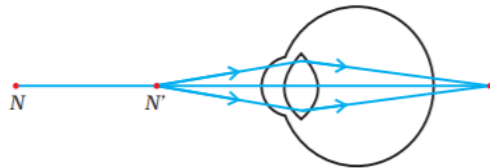

- (i) Which defect of vision is represented in this case?
Give reason for your answer. 1
- (ii) What could be the two causes of this defect? 2
- (iii) With the help of a diagram show how this defect can be corrected using a suitable lens. 2