

**GATE 2012 Online Examination**  
**AG : AGRICULTURAL ENGINEERING**

Duration: Three Hours

Maximum Marks: 100

**Read the following instructions carefully.**

1. The computer allotted to you at the examination center runs a specialized software that permits only one answer to be selected for multiple choice questions using a mouse. Your answers shall be updated and saved on a server periodically and at the end of the examination.
2. To login, enter your Registration Number and password provided in the envelope. Go through the symbols used in the test and understand the meaning before you start the examination. You can view all questions by clicking on the View All Questions button in the screen after the start of the examination.
3. To answer a question, select the question using the selection panel on the screen and choose the correct answer by clicking on the radio button next to the answer. To change the answer, just click on another option. If you wish to leave a previously answered question unanswered, click on the button next to the selected option.
4. The examination will automatically stop at the end of 3 hours.
5. There are a total of 65 questions carrying 100 marks. Except questions Q.26 – Q.30, all the other questions are of multiple choice type with only **one** correct answer. Questions Q.26 - Q.30 require a numerical answer, and a number should be entered using the virtual keyboard on the monitor.
6. Questions Q.1 – Q.25 carry 1 mark each. Questions Q.26 – Q.55 carry 2 marks each. The 2 marks questions include two pairs of common data questions and two pairs of linked answer questions. The answer to the second question of the linked answer questions depends on the answer to the first question of the pair. If the first question in the linked pair is wrongly answered or is unattempted, then the answer to the second question in the pair will not be evaluated.
7. Questions Q.56 – Q.65 belong to General Aptitude (GA) section and carry a total of 15 marks. Questions Q.56 – Q.60 carry 1 mark each, and questions Q.61 – Q.65 carry 2 marks each.
8. Unattempted questions will result in zero mark and wrong answers will result in **NEGATIVE** marks. There is no negative marking for questions of numerical answer type, i.e., for Q.26 – Q.30. For all 1 mark questions,  $\frac{1}{3}$  mark will be deducted for each wrong answer. For all 2 marks questions,  $\frac{2}{3}$  mark will be deducted for each wrong answer. However, in the case of the linked answer question pair, there will be negative marks only for wrong answer to the first question and no negative marks for wrong answer to the second question.
9. Calculator is allowed. Charts, graph sheets or tables are **NOT** allowed in the examination hall. Do the rough work in the Scribble Pad provided.
10. You must sign this sheet and leave it with the invigilators at the end of the examination.

---

**DECLARATION:** I hereby declare that I have read and followed all the instructions given in this sheet.

<b>Registration Number</b>	<b>AG</b>							
<b>Name</b>								
<b>Signature</b>								

<b>Verified that the above entries are correct.</b> Invigilator's signature:	
---------------------------------------------------------------------------------	--

---

**Q. 1 – Q. 25 carry one mark each.**

- Q.1 The matrix  $\begin{bmatrix} 0 & 2 & -3 \\ -2 & 0 & 4 \\ 3 & -4 & 0 \end{bmatrix}$  is
- (A) diagonal (B) symmetric (C) skew symmetric (D) triangular
- Q.2 The line  $y = x - 1$  can be expressed in polar coordinates  $(r, \theta)$  as
- (A)  $r = \cos \theta$  (B)  $r = \sin \theta$   
 (C)  $r(\cos \theta + \sin \theta) = 1$  (D)  $r(\cos \theta - \sin \theta) = 1$
- Q.3 The type of pump used in forced water cooling system of a tractor engine is
- (A) piston (B) centrifugal (C) gear (D) vane
- Q.4 Which one of the following statements is NOT appropriate regarding cone index
- (A) It reflects strength of soil  
 (B) It is a composite parameter  
 (C) It is dimensionless  
 (D) It is measured at a constant penetration rate of 30 mm/s
- Q.5 The draft and total power requirement of a rotary cultivator operating in concurrent mode as compared to a spring tyne cultivator of equal cutting width under the same operating conditions, respectively are
- (A) higher and higher (B) lower and lower  
 (C) lower and higher (D) higher and lower
- Q.6 The soil erodibility factor needs to be determined for use in the universal soil loss equation. The length, in m and slope, in % of the experimental plot to be used for this purpose, respectively are
- (A) 19, 12 (B) 21, 11 (C) 22, 9 (D) 23, 8
- Q.7 The difference between Fore Bearing and Back Bearing of a traverse line is
- (A) exactly  $90^\circ$  (B) less than  $180^\circ$  (C) exactly  $180^\circ$  (D) greater than  $180^\circ$
- Q.8 A pumping device that combines the advantages of both centrifugal and reciprocating pumps is known as
- (A) air lift pump (B) hydraulic ram  
 (C) jet pump (D) rotary pump
- Q.9 If  $\nu$  is the kinematic viscosity of air – water vapour mixture and  $D_{AB}$  is the mass diffusivity of water vapour in air then the ratio  $\nu / D_{AB}$  is known as
- (A) Stanton number (B) Prandtl number  
 (C) Schmidt number (D) Sherwood number
- Q.10 Work index in size reduction can be obtained by multiplying Bond's energy constant with
- (A) 10 (B)  $\sqrt{10}$  (C)  $\sqrt[3]{10}$  (D)  $\sqrt[4]{10}$

- Q.11 The tangent line to  $y = f(x)$  at the point  $(x_0, y_0)$ , assuming  $f'(x) \neq 0$ , intersects the  $x$  axis at
- (A)  $(x_0 - [y_0/f'(x_0)], 0)$  (B)  $(x_0 + [y_0/f'(x_0)], 0)$   
(C)  $(x_0 - [f'(x_0)/y_0], 0)$  (D)  $(x_0 + [f'(x_0)/y_0], 0)$
- Q.12 Approximate percentage of scores that fall within  $\pm\sigma$  (standard deviation) of the mean in a normal distribution is
- (A) 34 (B) 68 (C) 95 (D) 99
- Q.13 The integrating factor of the differential equation  $(x+1) \frac{dy}{dx} - y = \sin x$  is
- (A)  $x$  (B)  $(x+1)$  (C)  $1/x$  (D)  $1/(x+1)$
- Q.14 The constituent of producer gas which occupies the highest percentage by volume and helps in increasing its overall calorific value is
- (A) CO (B) CO<sub>2</sub> (C) H<sub>2</sub> (D) CH<sub>4</sub>
- Q.15 During field operation, the shank of a tractor drawn rigid tyne sweep type cultivator is mainly subjected to
- (A) bending (B) shear (C) torsion (D) bending and torsion
- Q.16 A slider is moving on a straight link at a sliding velocity of  $0.5 \text{ m s}^{-1}$ . The straight link is pivoted at one end and makes angular movement at a rate of  $1.0 \text{ rad s}^{-1}$ . Coriolis acceleration of the slider in  $\text{m s}^{-2}$  is
- (A) 0.25 (B) 0.50 (C) 1.00 (D) 4.00
- Q.17 The power developed and the exhaust gas temperature of a diesel engine compared to a spark ignition engine of the same size and running at the same speed respectively, are
- (A) higher and lower (B) higher and higher  
(C) lower and higher (D) lower and lower
- Q.18 In a semi-modular outlet, the discharge
- (A) is independent of water levels in the distributary and the water course  
(B) depends upon the water levels of both distributary and water course  
(C) depends upon the water level in the distributary  
(D) depends upon the water level in the water course
- Q.19 The relationship between outflow  $Q$  in  $\text{m}^3 \text{ s}^{-1}$  and storage  $S$  in  $\text{m}^3$  for an emergency spillway in a reservoir is  $Q = S/4000$ . Inflow, outflow and storage are assumed to be zero at time  $t = 0$ . If the inflow rate is  $300 \text{ m}^3 \text{ s}^{-1}$  at the end of  $t = 3$  hours, the outflow rate in  $\text{m}^3 \text{ s}^{-1}$  is
- (A) 152.84 (B) 164.84 (C) 172.34 (D) 184.84
- Q.20 A trapezoidal grassed waterway is constructed along a longitudinal gradient of 4%. If the cross-sectional area of flow is  $1.52 \text{ m}^2$ , wetted perimeter is  $12.5 \text{ m}$  and Manning's  $n$  for the waterway is  $0.04 \text{ m}^{-1/3} \text{ s}$ , the flow through the waterway in  $\text{m}^3 \text{ s}^{-1}$  is
- (A) 1.9 (B) 2.1 (C) 2.3 (D) 2.5

- Q.21 A single acting reciprocating pump discharges 3.5 litres of water per second at 40 rpm. The pump has a piston diameter of 150 mm and a stroke of 300 mm. The percentage slip is  
 (A) 0.85 (B) 1.97 (C) 3.53 (D) 6.05
- Q.22 A pair of parallel glass panes, each of 3 mm thickness traps 2 mm layer of stagnant air. Thermal conductivities of glass and air are 0.5 and  $0.02 \text{ W m}^{-1} \text{ K}^{-1}$ , respectively. If the film heat transfer coefficient of air is  $10 \text{ W m}^{-2} \text{ K}^{-1}$ , then Biot Number is  
 (A) 1.50 (B) 1.00 (C) 0.06 (D) 0.04
- Q.23 Two small parallel plane square surfaces, each measuring  $4 \text{ mm} \times 4 \text{ mm}$  are placed 0.5 m apart (centre to centre) with  $30^\circ$  angle between the radial distance and both the surface normals. The view factor between the two surfaces is  
 (A)  $1.53 \times 10^{-5}$  (B)  $1.76 \times 10^{-5}$  (C)  $3.82 \times 10^{-3}$  (D)  $4.41 \times 10^{-3}$
- Q.24 Tomato catsup with  $10 \text{ Pa s}^n$  consistency coefficient and 0.8 flow behaviour index is flowing in a pipe. Generalized coefficient of viscosity of catsup, in  $\text{Pa s}^n$  is  
 (A) 2.66 (B) 6.93 (C) 15.91 (D) 23.87
- Q.25 A packed bed of 480 kg solid particles having particle size of 0.15 mm and density of  $800 \text{ kg m}^{-3}$  is fluidized using air at  $25^\circ \text{C}$  and 1 atmospheric pressure. If the cross section of the empty bed is  $0.45 \text{ m}^2$  and voidage at minimum fluidizing condition is 0.5, then the minimum height of the fluidized bed, in m is  
 (A) 7.4 (B) 5.4 (C) 2.7 (D) 1.0

**Q. 26 to Q. 55 carry two marks each.**

- Q.26 The value of  $\int_0^{\pi/2} \cos x \, dx$  using trapezoidal rule with two equal intervals is  
 (A) 0.95 (B) 1.00 (C) 1.22 (D) 1.29
- Q.27 A tractor power take-off (PTO) driven stationary peg tooth type wheat thresher operating at a cylinder speed of 540 rpm requires a torque of 250 Nm at PTO. The minimum net engine power required, in kW is  
 (A) 13 (B) 16 (C) 18 (D) 21
- Q.28 A border strip of  $8 \times 250 \text{ m}$  is being irrigated by a border stream of 50 lps. The infiltration capacity of the soil is  $25 \text{ mm h}^{-1}$  (assumed to be constant throughout the period of irrigation). The average depth of the advancing sheet of water over the land is 70 mm. The time required to irrigate the border strip, in minutes, will be  
 (A) 16.7 (B) 25.7 (C) 54.7 (D) 67.7
- Q.29 Decimal reduction times for *Bacillus subtilis* are 37 s and 12 s at temperatures of  $120^\circ \text{C}$  and  $125^\circ \text{C}$ , respectively. The temperature rise, in  $^\circ \text{C}$ , necessary to reduce the first value of decimal reduction time at  $120^\circ \text{C}$  by a factor of 10 is  
 (A) 7.18 (B) 10.36 (C) 13.06 (D) 16.07

- Q.30 A tall silo having height to diameter ratio of 2 is holding 480 tons wheat of bulk density  $960 \text{ kg m}^{-3}$ . The angle of internal friction for wheat is  $25^\circ$  and for wheat and wall surface is  $24^\circ$ . Applying Airy formula, the maximum lateral pressure in kPa at the bottom of the bin section is  
 (A) 40.24 (B) 41.79 (C) 42.83 (D) 42.92
- Q.31 The eigenvalues of the matrix  $\begin{bmatrix} 6 & 1 \\ -2 & 3 \end{bmatrix}$  are  
 (A) (3, 6) (B) (1, -2) (C) (5, 4) (D) (1, 6)
- Q.32 If  $f'(x) = e^x$  and  $f(0) = 5$ , then from Mean Value Theorem, the value of  $f(1)$  lies between  
 (A) 2 and  $(2 + e)$  (B) 3 and  $(2 + e)$  (C) 3 and  $(3 + e)$  (D) 6 and  $(5 + e)$
- Q.33 The inverse Laplace Transform of  $\frac{s^2}{(s-3)^3}$  can be written as  $\frac{e^{3t}}{2}[At^2 + Bt + C]$ . The values of  $A$ ,  $B$  and  $C$ , respectively are  
 (A) 3, 5 and 7 (B) 2, 10 and 12 (C) 10, 12 and 4 (D) 9, 12 and 2
- Q.34 A two wheel drive tractor, weighing 15.84 kN with a wheel base of 2160 mm, has the static weight divided between the front and rear axles in the ratio of 30 : 70 on a horizontal level surface. The hitch point is at a height of 700 mm from the ground and at a horizontal distance of 120 mm to the rear side from the center of the rear axle. Pull acts at an angle of  $12^\circ$  downwards from the horizontal. The maximum pull in kN, when the front wheels would just start rising from the ground is  
 (A) 1.48 (B) 14.46 (C) 39.04 (D) 85.54
- Q.35 A horizontal axis drag type wind mill with square blades and a horizontal axis lift type wind mill with airfoil section blades having same rotor size are installed at a height of 10 m above the ground. The average wind speed is  $25 \text{ km h}^{-1}$ . The maximum power coefficient for drag type and lift type wind mills is 0.148 and 0.593, respectively. If the maximum power extracted by drag type wind mill is 5 kW, the corresponding power extracted by lift type wind mill, in kW is  
 (A) 8.43 (B) 12.63 (C) 18.03 (D) 20.03
- Q.36 The thresher of a wheat combine harvester has an optimal throughput capacity of 2400 kg (crop) per hour. The harvester has a forward velocity of  $4.5 \text{ km h}^{-1}$ . Sample tests have revealed that the yield of crop in the field is 3000 kg (grain) per ha. Grain to straw ratio is 60 : 40. If the above throughput is to be maintained, the width of cut of the harvester in m, neglecting turning losses, is  
 (A) 0.71 (B) 1.07 (C) 1.78 (D) 2.96
- Q.37 In a disc clutch, the inside and outside radii of the clutch plate are 50 and 100 mm, respectively. If the axial force exerted on the disc is 4 kN, the maximum pressure experienced by the clutch plate in  $\text{N mm}^{-2}$  under uniform wear conditions is  
 (A) 0.13 (B) 0.17 (C) 0.25 (D) 0.51
- Q.38 A regime channel carrying a discharge of  $25 \text{ m}^3 \text{ s}^{-1}$  is designed using Lacey's regime theory. The side slope of the channel is  $\frac{1}{2} H : 1 V$ , and Lacey's silt factor is unity. The bottom width and depth of flow in the channel, in m, respectively are  
 (A) 20.26, 1.38 (B) 20.26, 1.56 (C) 23.75, 1.56 (D) 32.78, 1.56

- Q.39 Flow is taking place through a layered soil system, having two homogeneous soils M and N, as shown in the figure. The head lost in soil N is 20 times the head lost in soil M.

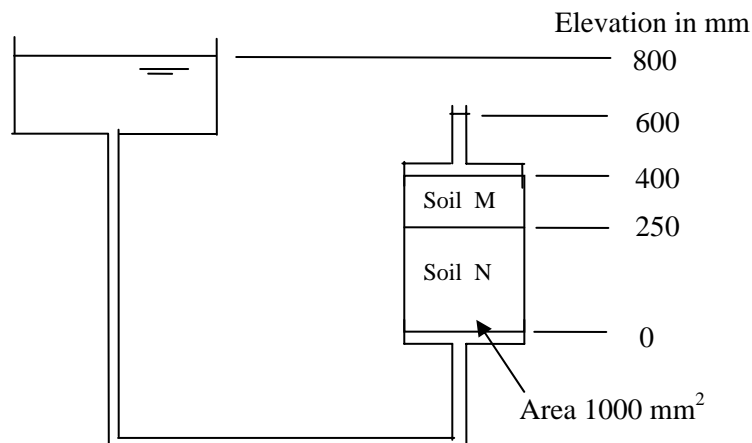

- If the permeability of soil M is  $3 \times 10^{-4} \text{ mm s}^{-1}$ , the permeability of soil N, in  $\text{mm s}^{-1}$ , will be
- (A)  $4 \times 10^{-4}$       (B)  $3 \times 10^{-4}$       (C)  $2.5 \times 10^{-5}$       (D)  $1.5 \times 10^{-5}$
- Q.40 A trapezoidal canal, having a bottom width of 5.0 m and a side slope of 1 H : 1 V, is carrying a discharge of  $20 \text{ m}^3 \text{ s}^{-1}$ . The critical depth, in m, is
- (A) 1.09      (B) 1.18      (C) 2.12      (D) 2.62
- Q.41 A 200 mm well fully penetrates a confined aquifer. After a long period of pumping at a rate of 1400 litres per minute, the drawdowns in the observation wells located at 25 m and 40 m from the pumping well are found to be 2.6 m and 1.9 m, respectively. The transmissivity of the aquifer in  $\text{m}^2 \text{ day}^{-1}$  is
- (A) 190      (B) 198      (C) 206      (D) 215
- Q.42 Tile drains have to be installed in an agricultural land having soil permeability of  $2.3 \times 10^{-3} \text{ mm s}^{-1}$ . An impermeable stratum exists at 3.2 m below the land surface, and it is desired to keep the water level at least 1.0 m below the land surface. The average discharge of the drainage system is  $2.0 \text{ mm day}^{-1}$ . If the tile drains are planned to be placed at 1.5 m below the land surface, the drain spacing in m, assuming the equivalent depth to be the same as the tile depth, is
- (A) 10.6      (B) 12.4      (C) 13.9      (D) 19.7
- Q.43 It is proposed to construct bench terraces on a 10% hill slope. If the batter slope is  $\frac{1}{2} \text{ H} : 1 \text{ V}$ , the percentage area that will be lost for cultivation due to bench terracing is
- (A) 4.68      (B) 5.47      (C) 6.25      (D) 6.78
- Q.44 Air at  $70^\circ \text{C}$  and 0.015 humidity ratio is cooled adiabatically by spraying water. The final temperature of the air is  $55^\circ \text{C}$ . Specific heat capacities of dry air and water vapour are  $1.005$  and  $1.88 \text{ kJ kg}^{-1} \text{ K}^{-1}$ , respectively and latent heat of vapourization of water at  $0^\circ \text{C}$  is  $2501.7 \text{ kJ kg}^{-1}$ . The absolute humidity of the outlet air, in kg water vapour per kg dry air is
- (A) 0.017      (B) 0.019      (C) 0.021      (D) 0.023

- Q.45 Final mass flow rate of osmotically dehydrated cherries after finish drying from 18% dry basis moisture content to 11.5% wet basis moisture content is 5000 kg per hour. The dryer efficiency is 70%, latent heat of vapourization is  $2345 \text{ kJ kg}^{-1}$ , specific heat of air is  $1.005 \text{ kJ kg}^{-1} \text{ K}^{-1}$ , drying temperature is  $50 \text{ }^\circ\text{C}$  and the specific volume of ambient air at  $25 \text{ }^\circ\text{C}$  is  $0.866 \text{ m}^3 \text{ kg}^{-1}$ . The necessary air flow requirement for the drying system in  $\text{m}^3 \text{ min}^{-1}$  is
- (A) 477                      (B) 587                      (C) 625                      (D) 702
- Q.46 A single effect vacuum evaporator has 100 tubes of 25 mm diameter. One thousand kg feed of milk per hour with 15% TS is concentrated to 20% TS in the evaporator. Film heat transfer coefficients on either sides of the tube are  $5000$  and  $800 \text{ W m}^{-2} \text{ K}^{-1}$ . Thermal conductivity of 1.5 mm thick SS tubes is  $15 \text{ W m}^{-1} \text{ K}^{-1}$ . Latent heat of vapourization under vacuum is  $2309 \text{ kJ kg}^{-1}$ . For  $10 \text{ }^\circ\text{C}$  temperature difference across the tube wall, the height of each tube, in m is
- (A) 1.36                      (B) 2.13                      (C) 2.56                      (D) 3.17
- Q.47 One thousand units of mixed fruit bar, each weighing 100 g with a surface area of  $0.01 \text{ m}^2$ , are frozen from  $70 \text{ }^\circ\text{C}$  molten mass condition to  $-20 \text{ }^\circ\text{C}$  frozen storage condition within 3 hours. The specific heat capacity values of the bar are  $3.6 \text{ kJ kg}^{-1} \text{ K}^{-1}$  and  $1.97 \text{ kJ kg}^{-1} \text{ K}^{-1}$  before and after freezing point ( $0 \text{ }^\circ\text{C}$ ) respectively. If the latent heat of crystallization is  $250 \text{ kJ kg}^{-1}$ , the cooling capacity of the refrigeration unit required in tons of refrigeration is
- (A) 0.77                      (B) 1.43                      (C) 1.66                      (D) 4.32

### Common Data Questions

Common Data for Questions 48 and 49:

A diesel engine running in dual fuel mode with diesel as pilot fuel and producer gas as primary fuel produces 3.5 kW at rated engine speed and is coupled directly to a generator for producing electricity. The amount of diesel and producer gas consumed per hour is 460 ml and  $12.5 \text{ m}^3$ , respectively.

- Q.48 Assuming calorific value of diesel and producer gas as 35280 and  $3.97 \text{ MJ m}^{-3}$ , respectively, the brake thermal efficiency of the engine in percentage is
- (A) 17.19                      (B) 19.13                      (C) 22.79                      (D) 25.32
- Q.49 If generator efficiency is 90%, the maximum electricity produced, in kW is
- (A) 2.85                      (B) 3.00                      (C) 3.15                      (D) 3.50

Common Data for Questions 50 and 51:

The hourly discharge observations at the mouth of a watershed due to 2 cm excess rainfall during 0 to 1 h and 3 cm excess rainfall during 1 to 2 h are given in the table below. Assume a constant base flow of  $1 \text{ m}^3 \text{ s}^{-1}$ .

Time (h)	0	1	2	3	4	5	6
Discharge ( $\text{m}^3 \text{ s}^{-1}$ )	1	7	26	37	27	13	1

- Q.50 The area of the watershed, in  $\text{km}^2$  is
- (A) 7.56                      (B) 8.24                      (C) 8.35                      (D) 8.86
- Q.51 The peak of 1 h unit hydrograph in  $\text{m}^3 \text{ s}^{-1}$  for the watershed and its time of occurrence in h, respectively are
- (A) 6, 1                      (B) 7, 2                      (C) 8, 2                      (D) 9, 1

## Linked Answer Questions

Statement for Linked Answer Questions 52 and 53:

Soybean is to be planted with a precision planter that meters 54 seeds per revolution of the metering disc powered from a ground wheel of diameter 490 mm. The desired plant population is 44800 per ha with a row to row spacing of 0.75 m. The germination percentage is 84. The planter is to be operated at  $2.5 \text{ km h}^{-1}$  with a 10% skid of ground wheel.

Q.52 The angular speed of ground wheel in rpm is

- (A) 20.3                      (B) 24.6                      (C) 28.3                      (D) 32.6

Q.53 The angular speed ratio of metering disc to ground wheel for obtaining the desired plant population is

- (A) 0.125:1                      (B) 0.150:1                      (C) 0.225:1                      (D) 0.250:1

Statement for Linked Answer Questions 54 and 55:

A 1 hp motor is used for running a dual cylinder reciprocating compressor of a refrigeration system based on R-134a refrigerant having  $185 \text{ kJ kg}^{-1}$  cooling capacity. COP of the system is 4.2 and overall efficiency of the compressor is 80%. Specific volume of the refrigerant vapour at suction temperature is  $0.15 \text{ m}^3 \text{ kg}^{-1}$ . The compressor with bore diameters of 40 mm each runs at 1440 rpm.

Q.54 The mass flow rate of the refrigerant in  $\text{kg min}^{-1}$  is

- (A) 1.634                      (B) 1.090                      (C) 0.813                      (D) 0.240

Q.55 The compressor stroke length in mm is

- (A) 16.8                      (B) 33.7                      (C) 50.5                      (D) 67.4



**General Aptitude (GA) Questions****Q. 56 – Q. 60 carry one mark each.**

Q.56 Choose the most appropriate alternative from the options given below to complete the following sentence:

**I \_\_\_ to have bought a diamond ring.**

- (A) have a liking (B) should have liked  
(C) would like (D) may like

Q.57 Choose the most appropriate alternative from the options given below to complete the following sentence:

**Food prices \_\_\_ again this month.**

- (A) have raised (B) have been raising  
(C) have been rising (D) have arose

Q.58 Choose the most appropriate alternative from the options given below to complete the following sentence:

**The administrators went on to implement yet another unreasonable measure, arguing that the measures were already \_\_\_ and one more would hardly make a difference.**

- (A) reflective (B) utopian (C) luxuriant (D) unpopular

Q.59 Choose the most appropriate alternative from the options given below to complete the following sentence:

**To those of us who had always thought him timid, his \_\_\_ came as a surprise.**

- (A) intrepidity (B) inevitability (C) inability (D) inertness

Q.60 The arithmetic mean of five different natural numbers is 12. The largest possible value among the numbers is

- (A) 12 (B) 40 (C) 50 (D) 60

**Q. 61 - Q. 65 carry two marks each.**

Q.61 Two policemen, A and B, fire once each at the same time at an escaping convict. The probability that A hits the convict is three times the probability that B hits the convict. If the probability of the convict not getting injured is 0.5, the probability that B hits the convict is

- (A) 0.14 (B) 0.22 (C) 0.33 (D) 0.40

- Q.62 The total runs scored by four cricketers P, Q, R, and S in years 2009 and 2010 are given in the following table:

Player	2009	2010
P	802	1008
Q	765	912
R	429	619
S	501	701

The player with the lowest percentage increase in total runs is

- (A) P                      (B) Q                      (C) R                      (D) S
- Q.63 If a prime number on division by 4 gives a remainder of 1, then that number can be expressed as
- (A) sum of squares of two natural numbers  
(B) sum of cubes of two natural numbers  
(C) sum of square roots of two natural numbers  
(D) sum of cube roots of two natural numbers

- Q.64 Two points  $(4, p)$  and  $(0, q)$  lie on a straight line having a slope of  $3/4$ . The value of  $(p - q)$  is
- (A) -3                      (B) 0                      (C) 3                      (D) 4

- Q.65 **In the early nineteenth century, theories of social evolution were inspired less by Biology than by the conviction of social scientists that there was a growing improvement in social institutions. Progress was taken for granted and social scientists attempted to discover its laws and phases.**

Which one of the following inferences may be drawn with the greatest accuracy from the above passage?

Social scientists

- (A) did not question that progress was a fact.  
(B) did not approve of Biology.  
(C) framed the laws of progress.  
(D) emphasized Biology over Social Sciences.

**END OF THE QUESTION PAPER**