

Standard IX

MATHEMATICS

PART-I



Government of Kerala
Department of General Education

State Council of Educational Research and Training (SCERT)

2019

THE NATIONAL ANTHEM

Jana-gana-mana adhinayaka, jaya he
Bharatha-bhagya-vidhata.
Punjab-Sindh-Gujarat-Maratha
Dravida-Utkala-Banga
Vindhya-Himachala-Yamuna-Ganga
Uchchala-Jaladhi-taranga
Tava subha name jage,
Tava subha asisa mage,
Gahe tava jaya gatha.
Jana-gana-mangala-dayaka jaya he
Bharatha-bhagya-vidhata.
Jaya he, jaya he, jaya he,
Jaya jaya jaya, jaya he!

PLEDGE

India is my country. All Indians are my brothers and sisters.

I love my country, and I am proud of its rich and varied heritage. I shall always strive to be worthy of it.

I shall give respect to my parents, teachers and all elders and treat everyone with courtesy.

I pledge my devotion to my country and my people. In their well-being and prosperity alone lies my happiness.

Prepared by :

State Council of Educational Research and Training (SCERT)

Poojappura, Thiruvananthapuram 695 012, Kerala

Website : www.scertkerala.gov.in

E-mail : scertkerala@gmail.com

Phone : 0471-2341883, Fax : 0471-2341869

Typesetting and Layout : SCERT

Printed at : KBPS, Kakkanad, Kochi-30

© Department of Education, Government of Kerala



Dear children,

Man invented various types of numbers to understand the world through measurements and the relations between measures. You have already seen how natural numbers and fractions evolved like this and how their operations were defined based on the physical contexts in which they were used. In this book, you can get acquainted with measures which cannot be indicated by natural numbers or fractions and the new kind of numbers used to represent them.

The study of geometry also continues in this book. We discuss the relations between parallel lines, triangles and circles. We have explained how new geometric theorems and applications arise from the recognition of such relations. We have also described how the program **GeoGebra** can be used to present geometry in a dynamic manner. More material are made available through the **Samagra** portal and QR codes.

With love and regards

Dr. J. Prasad
Director, SCERT

CONSTITUTION OF INDIA

Part IV A

FUNDAMENTAL DUTIES OF CITIZENS

ARTICLE 51 A

Fundamental Duties- It shall be the duty of every citizen of India:

- (a) to abide by the Constitution and respect its ideals and institutions, the National Flag and the National Anthem;
- (b) to cherish and follow the noble ideals which inspired our national struggle for freedom;
- (c) to uphold and protect the sovereignty, unity and integrity of India;
- (d) to defend the country and render national service when called upon to do so;
- (e) to promote harmony and the spirit of common brotherhood amongst all the people of India transcending religious, linguistic and regional or sectional diversities; to renounce practices derogatory to the dignity of women;
- (f) to value and preserve the rich heritage of our composite culture;
- (g) to protect and improve the natural environment including forests, lakes, rivers, wild life and to have compassion for living creatures;
- (h) to develop the scientific temper, humanism and the spirit of inquiry and reform;
- (i) to safeguard public property and to abjure violence;
- (j) to strive towards excellence in all spheres of individual and collective activity so that the nation constantly rises to higher levels of endeavour and achievements;
- (k) who is a parent or guardian to provide opportunities for education to his child or, as the case may be, ward between age of six and fourteen years.





The header features a ruler at the top with numbers 0 through 15. Above the ruler, a purple dot is connected to the word 'Contents' by two black arrows. To the right of the ruler is a circular diagram divided into eight colored segments (3, 1, 15, 13, 11, 9, 7, 5) with a black arrow pointing to the segment labeled '1'.

Contents

1. Area	7
2. Decimal Forms.....	23
3. Pairs of Equations	33
4. New Numbers	43
5. Circles.....	63
6. Parallel Lines	79
7. Similar Triangles	95



A right-angled triangle is shown with a horizontal base of length 40 and a vertical height labeled h . The angle between the base and the hypotenuse is 30° . A small tree icon is drawn at the top of the height h .

30°

40

Certain icons are used in this textbook for convenience

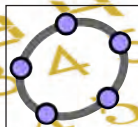

Computer Work



Additional Problems



Project

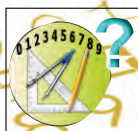

For Discussion



We want to draw a rectangle of area 12 square centimetres. How do we do it?

It can be like this:

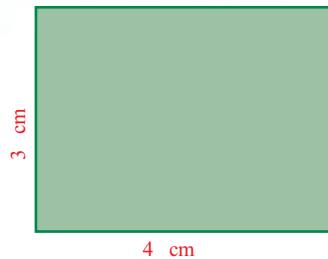

Or like this:

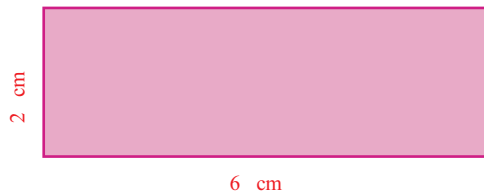

And there are so many other ways, right?

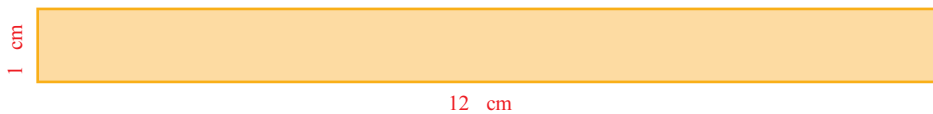

Suppose we also want one side to be 8 centimetres long. There is only one such rectangle, isn't it?

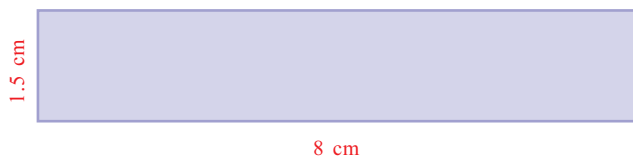

Make a slider a with $\text{Min} = 0$ and $\text{Max} = 50$. Draw a line of length a and draw perpendiculars through its ends. Draw circles centred on the ends of the line with radii $12/a$ and mark the points of intersection with the perpendiculars. Complete the rectangle using **Polygon** tool and hide the lines and circles. As we move the slider, we get different rectangles of area 12.



What if we want a triangle of area 12 square centimetres?

Again it can be done in many ways:

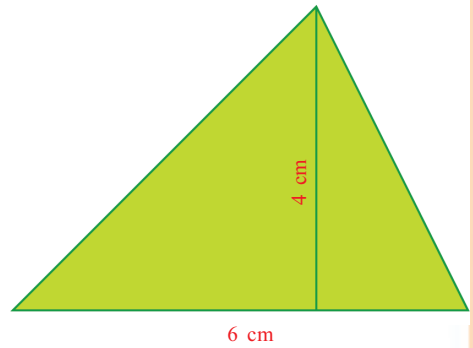
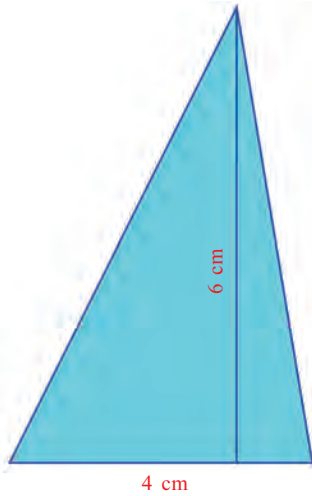

And if we want one side to be 8 centimetres?

Then also there are several:

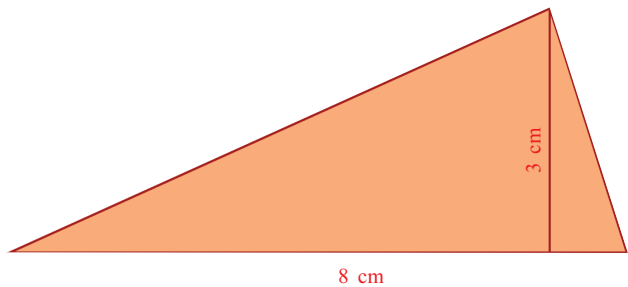
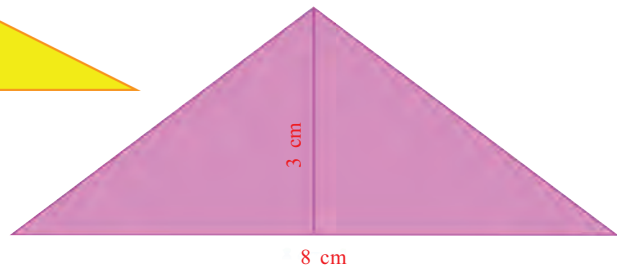
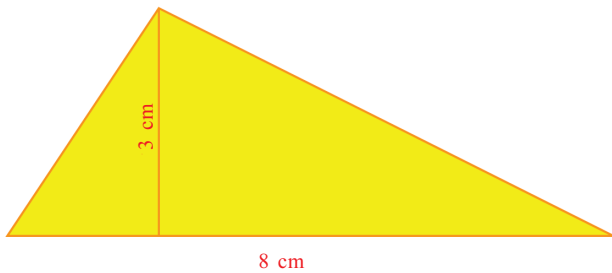

Make a slider a with $\text{min}=0$ and $\text{max}=5$ and a line AB of length a . Draw the perpendicular to the line through A . Draw a circle centered at A with radius $24/a$. Mark the point C , where the circle cuts the perpendicular. Draw the line through C , parallel to AB and mark a point D on it. Draw the triangle ABD and mark its area. By changing the value of the slider a and the position of the point D , we get different triangles of area 12. Fixing a at 8; if we shift D , then we get different triangles of one side 8 and area 12.

In all these, the sides are different, except for the base. Since the base and the height are the same, so is the area.



0 1 2 3 4 5 6 7 8 9

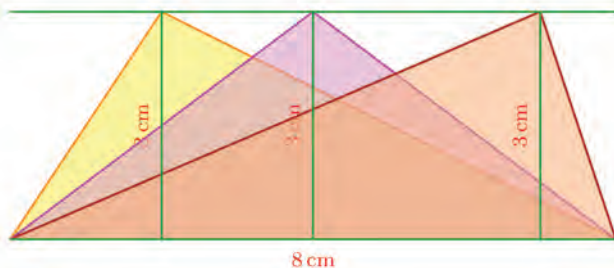

The top vertices of all these triangles lie 3 centimetres from the base. In other words, they are all on the line parallel to the base, at a distance 3 centimetres from it.

The top vertices of all triangles with this base and area must lie on this line. On the other hand, if we join any point on this line with the end points of the bottom line, we get a triangle of this base and area.

This is true whatever be the base and area, right?

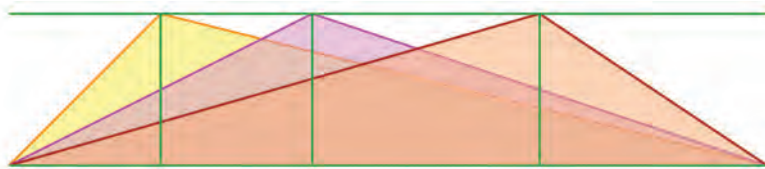

All triangles with the same base and area have their third vertices on a line parallel to the base; conversely, all triangles with the same base and the third vertex on a line parallel to the base have the same area.

Let's see some ways of putting this to use.

Draw a triangle of sides 4 centimetres, 5 centimetres and 6 centimetres.

Now can we draw an isosceles triangle with the same base and area?

Since we don't want to change the base, the only question is where to mark the top vertex. To have the same area, it must be on the line through the top vertex of the triangle we have drawn and parallel to the base.

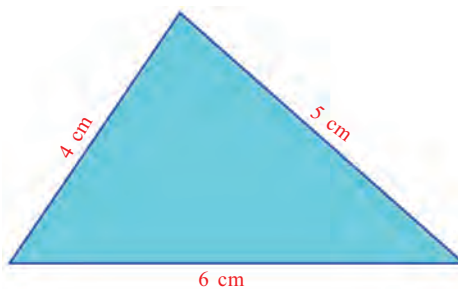

And we have seen in Class 8 that, the top vertex of any isosceles triangle is on the perpendicular bisector of the base.





So the third vertex we seek is the point where the perpendicular bisector of the base of the drawn triangle and the line through its top vertex parallel to the base intersect.

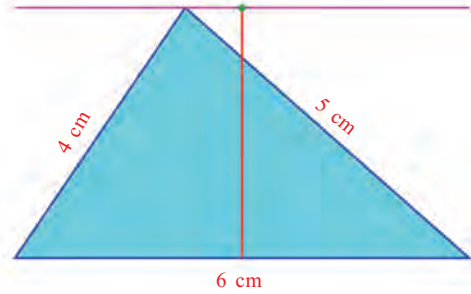

Now we can draw the required triangle:

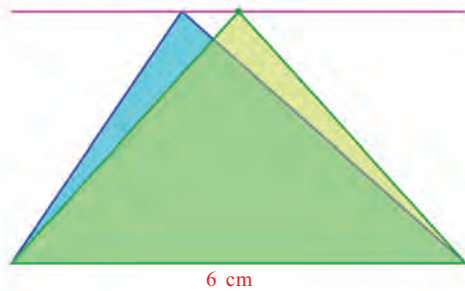

Again can you draw another triangle of the same base and area with the left side 7 centimetres?

All we need to do is to draw an arc of radius 7 centimetres, centred at the left vertex and intersecting the parallel line on top, right?

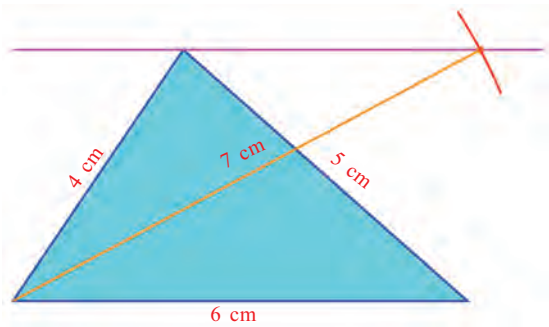

Thus we get a triangle like this:

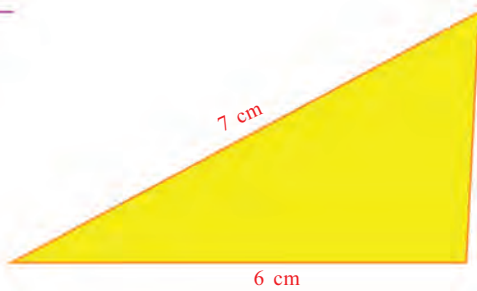
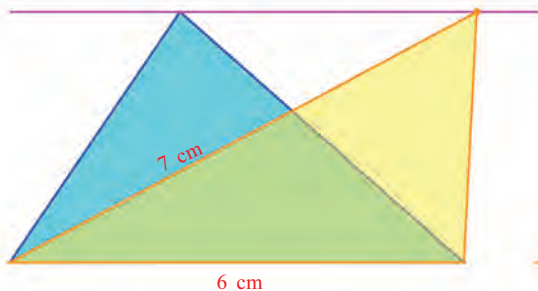

Can we draw an isosceles triangle of the same area with base 5 centimetres?

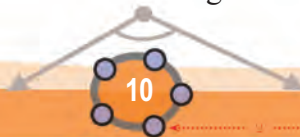

0 1 2 3 4 5 6 7 8 9



We can redraw our first picture with the 5 centimetre side at the bottom and proceed as before.

If we don't mind a tilted triangle, then we can do this using the first drawn triangle itself, by drawing a line through the left vertex parallel to the right side.

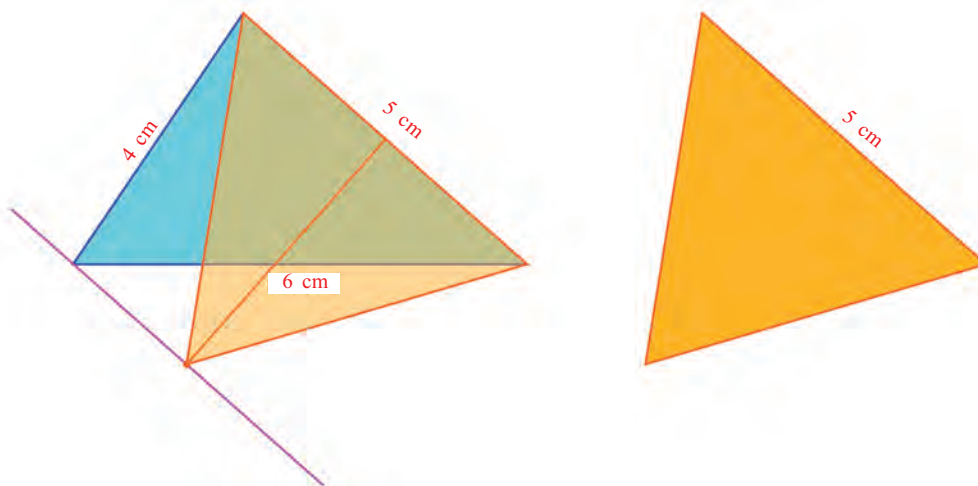

- (1) Draw a triangle of sides 3, 4 and 6 centimetres. Draw three different right triangles of the same area.
- (2) Draw the triangle shown below in your notebook:

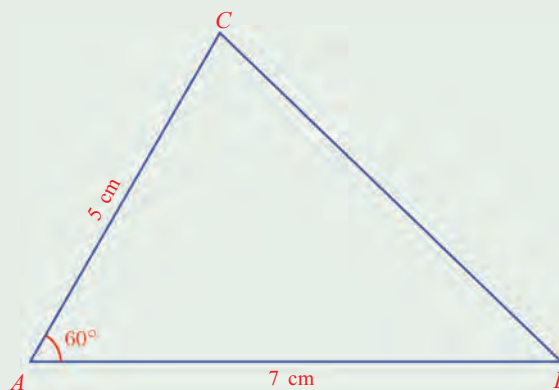

Draw triangles ABP , BCQ and CAR of the same area with measurements given below:

- i) $\angle BAP = 90^\circ$
- ii) $\angle BCQ = 60^\circ$
- iii) $\angle ACR = 30^\circ$



- (3) Draw a circle and a triangle with one vertex at the centre of the circle and the other two on the circle. Draw another triangle of the same area with all three vertices on the circle.
- (4) How many different (non - congruent) triangles can you draw with two sides 8 and 6 centimetres and area 12 square centimetres? What if the area is to be 24 square centimetres?



Draw line AB of length 4 and draw the circle centred at A with radius 3. Make an angle slider α and draw AB' with $\angle BAB' = \alpha$. (Choose angle with given size and click first on B and then on A. In the window that opens up, give α as angle size to get the point B'). Mark the point C where AB' cuts the circle. Draw the line parallel to AB through C and mark the point D where it meets the circle. Draw triangles ABC, ABD and mark their areas. What is the relation between $\angle BAC$ and $\angle BAD$? Change α and see.

- (5) In the picture below, the lines parallel to each side of the blue triangle through the opposite vertex are drawn to make the big triangle.

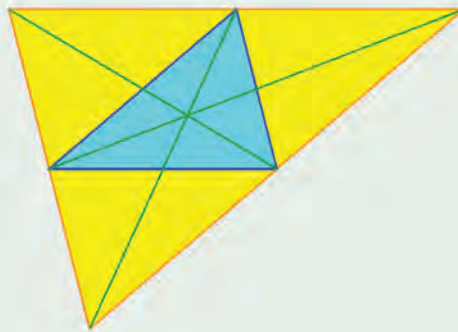

How many triangles in the picture have the same area as that of the blue triangle? How many of them have the same measures of the blue triangle?

- (6) Prove that the two triangles shown below have the same area:



How many different triangles of the same area can be drawn without changing the lengths of two sides?

Quadrilateral and triangle

How do we calculate the area of an ordinary quadrilateral without any special properties?

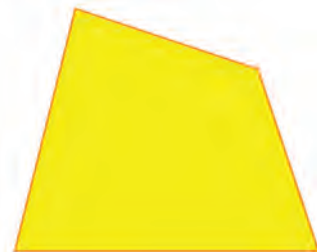

0 1 2 3 4 5 6 7 8 9

Draw a diagonal to divide it into two triangles and compute the area of each, right?

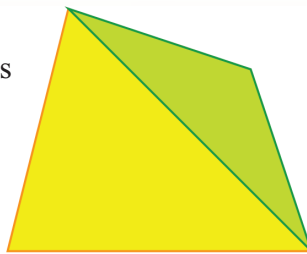

There is another way. Suppose we can bring down the top right vertex of the green triangle to the base of the quadrilateral without altering the area:

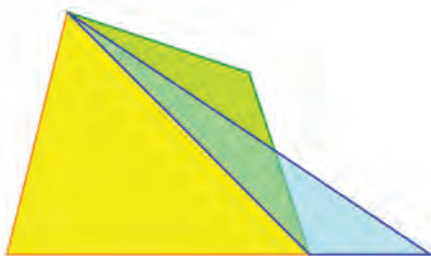

Then the area of the quadrilateral would be the sum of the yellow and blue triangles. And these two triangles together form a big triangle. Thus we can convert the area of the quadrilateral to the area of a single triangle.

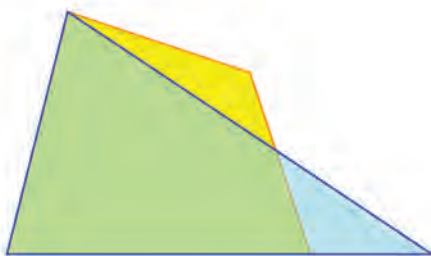

Now we see how this wish can be realised. To shift a vertex of the green triangle without altering the base and area, we need only draw a line through this vertex, parallel to the opposite side:

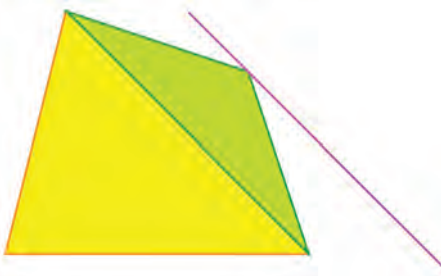

0 1 2 3 4 5 6 7 8 9





However much we slide the top right vertex of the green triangle along this line, its area won't change; so the area of the new quadrilateral thus got also does not change.

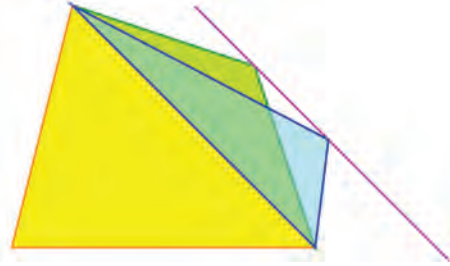

Cutting and rearranging

If we cut a paper figure and rearrange the pieces to another shape, the area is not altered. A geometric method of changing a figure into another may not always give a method to cut and rearrange. For example, the method of drawing a triangle of the same area as that of a quadrilateral cannot be used to cut a paper quadrilateral and rearrange the pieces to form a triangle. Several websites which give such dissection methods are given in the webpage www.cs.purdue.edu/homes/gnf/book/webdiss.html

What if we slide the vertex all the way down to the point where the parallel line meets the base of the quadrilateral extended?

We get a triangle of the same area as the quadrilateral, right?

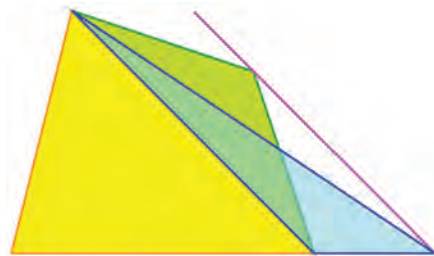

Repeating this trick again and again we can make a triangle of the same area as any polygon. For example, look at this pentagon:

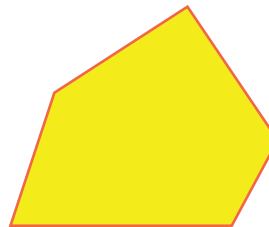

By joining two alternate vertices we can split it into a quadrilateral and a triangle:

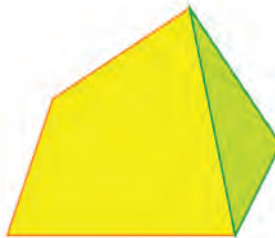

Draw a quadrilateral, a pentagon and a hexagon in GeoGebra and draw triangles of the same areas.



0 1 2 3 4 5 6 7 8 9

Now sliding down the top right corner of the green triangle parallel to the opposite side to the base of the pentagon, we get a quadrilateral of the same area:



Sliding down the top left vertex of the quadrilateral also like this, we get a triangle of the same area:

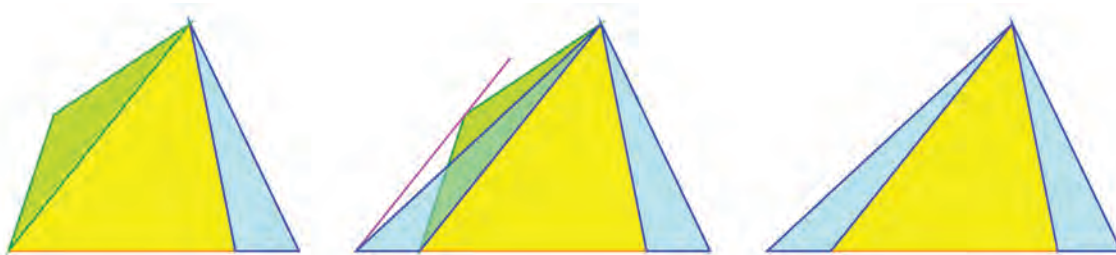

- (1) Draw the two quadrilaterals shown below, in your note book. Draw triangles of the same area and calculate the areas (The lengths needed may be measured).

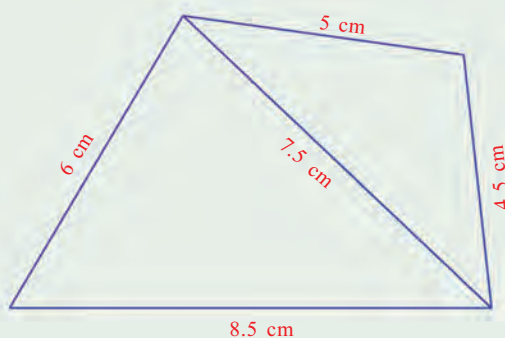
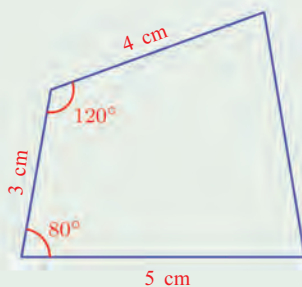

- (2) Draw a rhombus of sides 6 centimetres and one angle 60° ; then draw a right triangle of the same area.
- (3) Draw a regular pentagon and then a triangle of the same area. Calculate the area.



- (4) The picture shows a rectangle divided into two parts.

Instead of the broken line separating these parts, draw a straight line to divide the rectangle into two other parts of the same area. Calculate the areas of these parts.

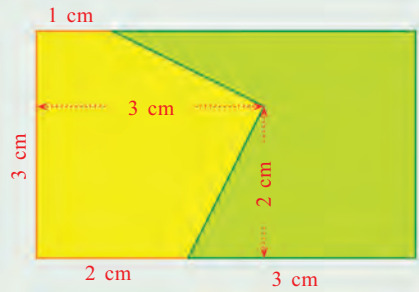

Triangle division

See these pictures:

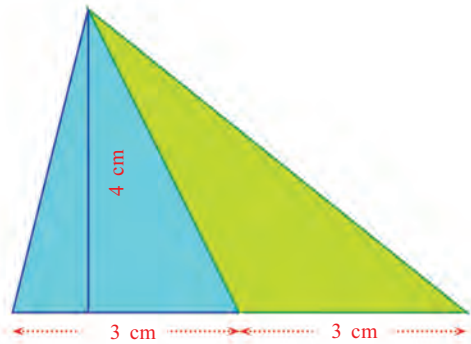
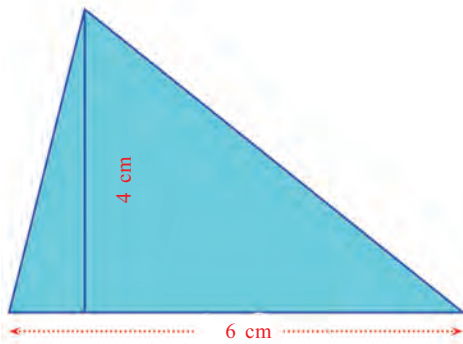

The line joining one vertex of the triangle to the midpoint of the opposite side divides it into two triangles.

What are the areas of these parts?

Both have bases of 3 centimetres.

And the heights? It's 4 centimetres for both.

So they have the same area, 6 square centimetres.

Now suppose the top vertex is joined to some other point of the bottom side.

For example, see this picture:

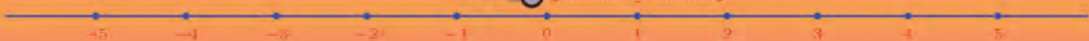
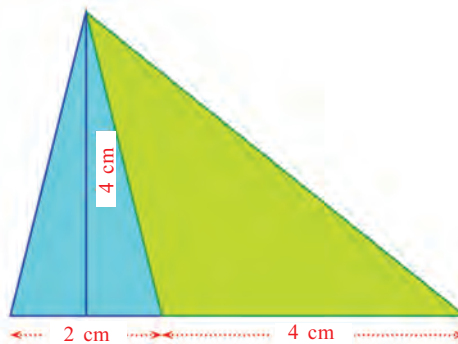

0 1 2 3 4 5 6 7 8 9



Now the smaller triangle is of area 4 square centimetres and the larger one is of area 8 square centimetres.

Thus the area of the larger triangle is twice the area of the smaller triangle. The bottom side is also divided in the same manner, right? The longer part is twice the shorter part.

We can put it in terms of ratios.

The bottom side is divided in the ratio 1 : 2; and the area of the triangle is also divided in the same ratio.

Is this true for other ways in which the line from the top vertex divides the bottom side?

What if this ratio is 2 : 3?

The lengths would be as below:

$$\text{Length of the shorter side} = 6 \times \frac{2}{5} \text{ centimetres}$$

$$\text{Length of the longer side} = 6 \times \frac{3}{5} \text{ centimetres}$$

And the areas?

$$\text{Area of the smaller part} = 6 \times \frac{2}{5} \times 2 = 12 \times \frac{2}{5} \text{ square centimetres}$$

$$\text{Area of the larger part} = 6 \times \frac{3}{5} \times 2 = 12 \times \frac{3}{5} \text{ square centimetres}$$

Thus the line from the top divides the area of the whole triangle in the ratio 2 : 3.

We can see in this way that whatever the ratio of lengths, the same is the ratio of areas. Even when we change the dimensions of the triangle, this fact does not change.

A line from the vertex of a triangle divides the length of the opposite side and the area of the triangle in the same ratio.

We saw that the bisector of a side of a triangle, through the opposite vertex bisects the triangle also. So a natural question is, in what ratio does the





bisector of an angle at one vertex divide the opposite side (and hence the triangle)?

The picture shows the angle bisector of the top vertex of the triangle.

We have to compute the ratio in which it divides the opposite side.

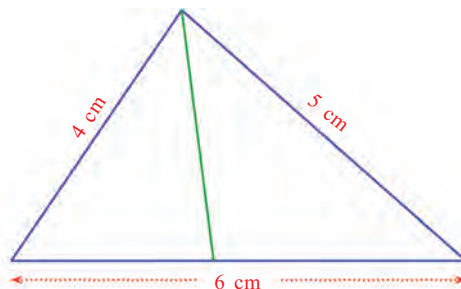

Here we know the lengths of one side of both the triangular parts. So let's compute the areas also in terms of these. For that, we draw the perpendiculars from the opposite vertex. It is the same point for both triangles.

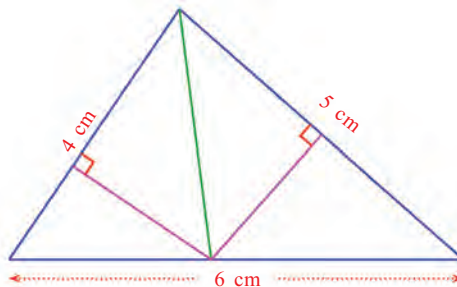

Don't these perpendiculars seem to have the same length?

Let's check. The upper right triangles on either side in the picture have the same hypotenuse. Since it is the angle bisector of the top angle of the large triangle, the top angles of these smaller triangles are equal. Since these triangles are right, the angles at the other end of the hypotenuse are also equal. So the perpendicular sides of these triangles are also equal. Thus the perpendiculars we have drawn are of the same length.

So, the areas of these triangles are 4 and 5 multiplied by half this length. That is, they are in the ratio 4 : 5.



0 1 2 3 4 5 6 7 8 9

As seen earlier, the angle bisector divides the opposite side also in the same ratio.

And this is true whatever be the lengths of the sides of the triangle.

In any triangle, the bisector of an angle divides the opposite side in the ratio of the sides of the angle.

This can be put in another way:

In the picture, the point marked on the bottom side divides that side in the ratio of the other two sides. As seen just now, the bisector of the top angle passes through this point. That is, the line joining the top vertex and this point is the bisector of the top angle.

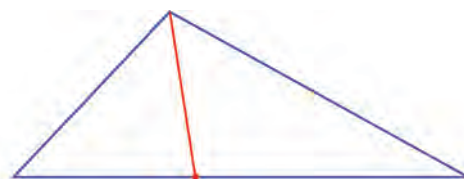
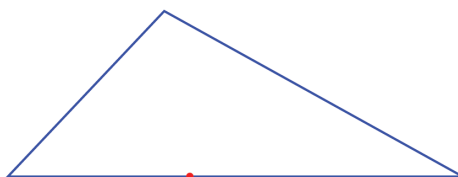

- (1) In the picture below, two lines are drawn from the top vertex of a triangle to the bottom side:



Prove that the ratio in which these lines divide the length of the bottom side is equal to the ratio of the areas of the three smaller triangles in the picture.



- (2) In the picture below, the top vertex of a triangle is joined to the mid point of the bottom side of the triangle and then the mid point of this line is joined to the other two vertices.

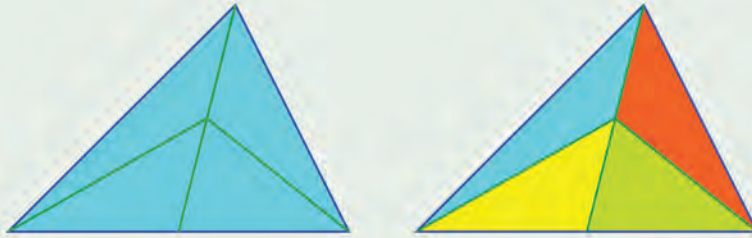

Prove that the areas of all four triangles obtained thus are equal to a fourth of the area of the whole triangle.

- (3) In the picture below, the top vertex of a triangle is joined to the mid point of the opposite side and then the point dividing this line in the ratio 2 : 1 is joined to the other two vertices:

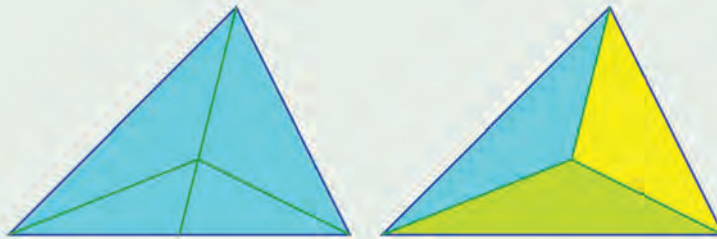

Prove that the areas of all three triangles in the picture on the right are equal to a third of the area of the whole triangle.

- (4) Prove that the lengths of the perpendiculars from any point on the bisector of an angle to the sides are equal.
- (5) In the picture below, the side AC of the triangle ABC is extended to D , by adding the length of the side CB . Then the line through C parallel to DB is drawn to meet AB at E .

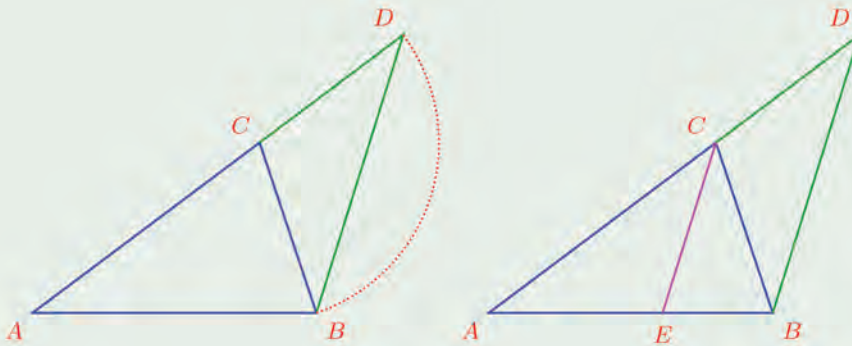

0 1 2 3 4 5 6 7 8 9



- i) Prove that CE bisects $\angle C$.
- ii) Describe how this can be used to divide an 8 centimetres long line in the ratio 4 : 5.
- iii) Can we use it to divide an 8 centimetres long line in the ratio 3 : 4? How?

Draw two parallel lines and mark points A, B, C and D on them.

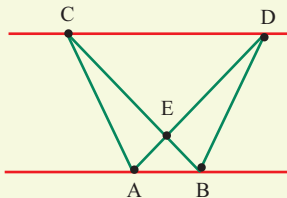

Draw the lines AD, BC and mark their point of intersection E. Draw triangles AEC, BED and mark their areas. What do you find? Change the position of the points and see.

- (6) In the figure, the diagonals of a quadrilateral split it into four triangles. The areas of three of them are shown in the picture:

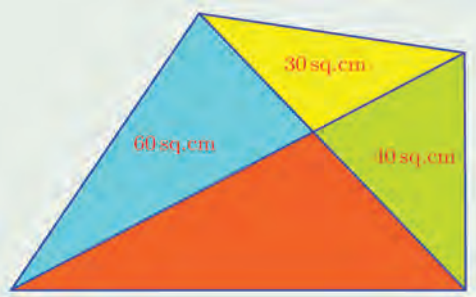

Calculate the area of the whole quadrilateral.

- (7) In this picture the horizontal lines at the top and bottom are parallel.



Prove that the yellow and red triangles are of the same area.



- (8) In the figure, the diagonals of a trapezium split it into four triangles.

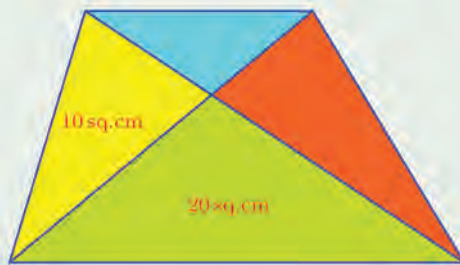

The area of the yellow triangle is 10 square centimetres and the area of the green triangle is 20 square centimetres. What is the area of the whole trapezium?

- (9) The picture below shows a trapezium divided into four parts by the diagonals.

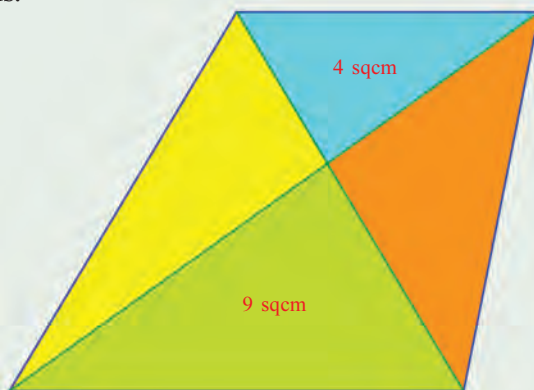

The area of the blue triangle is 4 square centimetres and the area of the green triangle is 9 square centimetres. What is the total area of the trapezium?

0 1 2 3 4 5 6 7 8 9





Decimal Forms



2

First forms

We have seen the decimal forms of some fractions in Class 6, haven't we?

For example, we can write

$$\frac{3}{10} = 0.3$$

$$\frac{29}{100} = 0.29$$

$$\frac{347}{1000} = 0.347$$

and so on.

On the other hand, any number in decimal form can be written using fractions with powers of 10 as denominators.

For example,

$$0.7 = \frac{7}{10}$$

$$0.91 = \frac{91}{100}$$

$$0.673 = \frac{673}{1000}$$

We can also split these using $\frac{1}{10}, \frac{1}{100}, \frac{1}{1000}, \dots$ as place values.

$$0.91 = \frac{91}{100} = \frac{90}{100} + \frac{1}{100} = \frac{9}{10} + \frac{1}{100}$$

$$0.671 = \frac{671}{1000} = \frac{600}{1000} + \frac{70}{1000} + \frac{1}{1000} = \frac{6}{10} + \frac{7}{100} + \frac{1}{1000}$$

So what does 0.03 mean?

Decimal fractions

We write natural numbers using 1, 10, 100, 1000 and so on. For example, 351 is the short-hand notation for

$$(3 \times 100) + (5 \times 10) + 1.$$

Writing in this form makes calculations easier. (Try multiplying 25 by 13, writing them as XXV and XIII)

It was the Dutch mathematician Simon Stevin, who first thought of writing fractions like this in terms of those with powers of 10 as denominators, such

as $\frac{1}{10}, \frac{1}{100}, \frac{1}{1000}, \dots$ and so on. This was in the sixteenth century. According to him, this would make computations easier.

For example, rather than calculating

$$\frac{3}{4} + \frac{2}{5} = \frac{23}{20} = 1\frac{3}{20}$$

it is easier to do

$$0.75 + 0.40 = 1.15$$



$$0.03 = \frac{0}{10} + \frac{3}{100} = \frac{3}{100}$$

What about 0.0203?

$$0.0203 = \frac{0}{10} + \frac{2}{100} + \frac{0}{1000} + \frac{3}{10000} = \frac{200}{10000} + \frac{3}{10000} = \frac{203}{10000}$$

Some fractions, whose denominators are not powers of 10 can be converted to such forms. For example, since $10 = 2 \times 5$, we can write

$$\frac{1}{2} = \frac{5}{10} = 0.5$$

$$\frac{1}{5} = \frac{2}{10} = 0.2$$

and then

$$\frac{2}{5} = \frac{2 \times 2}{5 \times 2} = \frac{4}{10} = 0.4$$

$$\frac{3}{5} = \frac{3 \times 2}{5 \times 2} = \frac{6}{10} = 0.6$$

$$\frac{4}{5} = \frac{4 \times 2}{5 \times 2} = \frac{8}{10} = 0.8$$

We could do this, because 2 and 5 are factors of 10. So, how do we write $\frac{1}{4}$ in the decimal form?

Though 4 is not a factor of 10, it is a factor of 100, as $4 \times 25 = 100$. Using this, we can write

$$\frac{1}{4} = \frac{1 \times 25}{4 \times 25} = \frac{25}{100} = 0.25$$

$$\frac{3}{4} = \frac{3 \times 25}{4 \times 25} = \frac{75}{100} = 0.75$$

and also,

$$\frac{1}{25} = \frac{1 \times 4}{25 \times 4} = \frac{4}{100} = 0.04$$

$$\frac{2}{25} = \frac{2 \times 4}{25 \times 4} = \frac{8}{100} = 0.08$$

$$\frac{13}{25} = \frac{13 \times 4}{25 \times 4} = \frac{52}{100} = 0.52$$



0 1 2 3 4 5 6 7 8 9

Now what about $\frac{1}{8}$?

8 is not a factor of 10 or 100. But since $8 = 2 \times 2 \times 2$, if we multiply it by 5 thrice, wouldn't it become the product of three 10's?

In the language of math,

$$2^3 \times 5^3 = (2 \times 5)^3 = 10^3 = 1000$$

That is,

$$8 \times 125 = 1000$$

Using this, we can write

$$\frac{1}{8} = \frac{1 \times 125}{8 \times 125} = \frac{125}{1000} = 0.125$$

$$\frac{3}{8} = \frac{3 \times 125}{8 \times 125} = \frac{375}{1000} = 0.375$$

and also

$$\frac{1}{125} = \frac{1 \times 8}{125 \times 8} = \frac{8}{1000} = 0.008$$

$$\frac{3}{125} = \frac{3 \times 8}{125 \times 8} = \frac{24}{1000} = 0.024$$

$$\frac{13}{125} = \frac{13 \times 8}{125 \times 8} = \frac{104}{1000} = 0.104$$

What about $\frac{3}{160}$?

First we factorize the denominator:

$$160 = 32 \times 5 = 2^5 \times 5$$

What power of 10 can we get from this by multiplication?

And what number should we multiply it with to get this?

$$160 \times 5^4 = (2^5 \times 5) \times 5^4 = 2^5 \times 5^5 = (2 \times 5)^5 = 10^5$$

So, we get

$$\frac{3}{160} = \frac{3 \times 5^4}{160 \times 5^4} = \frac{3 \times 625}{100000} = \frac{1875}{100000} = 0.01875$$

Now can you say what kind of fractions in general can be written in the decimal form?





(1) Write the fractions below in decimal form:

(i) $\frac{3}{20}$

(ii) $\frac{3}{40}$

(iii) $\frac{13}{40}$

(iv) $\frac{7}{80}$

(v) $\frac{5}{16}$

(2) Find the decimal form of the sums below:

(i) $\frac{1}{5} + \frac{1}{25} + \frac{1}{125}$

(ii) $\frac{1}{5} + \frac{1}{5^2} + \frac{1}{5^3} + \frac{1}{5^4}$

(iii) $\frac{1}{2} + \frac{1}{2^2} + \frac{1}{2^3}$

(3) A two-digit number divided by another two-digit number gives 5.875. What are the numbers?

New forms

We have seen how some fractions whose denominators were not powers of 10 to start with, could be converted to this form.

Can we transform $\frac{1}{3}$ like this?

We cannot get a power of 10 by multiplying 3 with any number (why?)

So, $\frac{1}{3}$ does not have a decimal form in the current sense.

But although no fraction with denominator a power of 10 is equal to $\frac{1}{3}$, we can compute fractions of this type closer and closer to $\frac{1}{3}$.

First let's find a fraction with denominator 10, which is close to $\frac{1}{3}$. For that, we divide 10 by 3 and write

$$\frac{10}{3} = 3\frac{1}{3}$$

Now $\frac{1}{3}$ is $\frac{1}{10}$ of $\frac{10}{3}$, isn't it? That is,



0 1 2 3 4 5 6 7 8 9

$$\frac{1}{3} = \frac{10}{3} \times \frac{1}{10}$$

Thus

$$\frac{1}{3} = \left(3 + \frac{1}{3}\right) \times \frac{1}{10} = \frac{3}{10} + \frac{1}{30}$$

We can write this as

$$\frac{1}{3} - \frac{3}{10} = \frac{1}{30}$$

Like this, we can find a fraction of denominator 100, which is close to $\frac{1}{3}$.

For that, first divide 100 by 3 and write

$$\frac{100}{3} = 33\frac{1}{3}$$

As before, we get from this,

$$\frac{1}{3} = \frac{100}{3} \times \frac{1}{100} = \left(33 + \frac{1}{3}\right) \times \frac{1}{100} = \frac{33}{100} + \frac{1}{300}$$

We can rewrite this as

$$\frac{1}{3} - \frac{33}{100} = \frac{1}{300}$$

$\frac{1}{300}$ is a lot smaller than $\frac{1}{30}$, right? So, the fraction $\frac{33}{100}$ is quite closer to

$\frac{1}{3}$ than $\frac{3}{10}$.

Continuing like this, we get

$$\frac{1}{3} - \frac{3}{10} = \frac{1}{30}$$

$$\frac{1}{3} - \frac{33}{100} = \frac{1}{300}$$

$$\frac{1}{3} - \frac{333}{1000} = \frac{1}{3000}$$

$$\frac{1}{3} - \frac{3333}{10000} = \frac{1}{30000}$$

and so on.

Summarizing, we find this:

The fractions, $\frac{3}{10}$, $\frac{33}{100}$, $\frac{333}{1000}$, ..., and so on get closer and closer to $\frac{1}{3}$.



We can slightly change this and say thus:

The fractions with decimal forms 0.3, 0.33, 0.333 and so on get closer and closer to $\frac{1}{3}$.

We write this fact in shorthand as $\frac{1}{3} = 0.333\dots$ Note carefully that the decimal form 0.333... in this is quite different from the decimal forms seen earlier.

We originally wrote in decimal form fractions with denominator a power of 10. For example, 0.3 is the decimal form of $\frac{3}{10}$ and 0.33 is the decimal form of $\frac{33}{100}$. But 0.333... is not the decimal form of a fraction with denominator a power of 10; it indicates a fraction which is approached closer and closer by a whole stream of fractions with denominators powers of 10. This fraction is $\frac{1}{3}$, as we have seen, and so we say that it is the decimal form of $\frac{1}{3}$.

Actually what we do here is to extend the original meaning of decimal forms in order to include numbers like $\frac{1}{3}$.

Let's look at another example. The fraction $\frac{1}{6}$ also doesn't have a form with denominator a power of 10 (why?) Let's find its decimal form also in the new sense.

As before, we divide 10, 100, 1000 and so on by 6 and write the results like this:

$$\frac{10}{6} = \frac{5}{3} = 1 \frac{2}{3}$$

$$\frac{100}{6} = \frac{50}{3} = 16 \frac{2}{3}$$

$$\frac{1000}{6} = \frac{500}{3} = 166 \frac{2}{3}$$



Next from these we find fractions with denominators powers of 10, which are close to $\frac{1}{6}$:

$$\frac{1}{6} = \left(1 + \frac{2}{3}\right) \times \frac{1}{10} = \frac{1}{10} + \frac{1}{15}$$

$$\frac{1}{6} = \left(16 + \frac{2}{3}\right) \times \frac{1}{100} = \frac{16}{100} + \frac{1}{150}$$

$$\frac{1}{6} = \left(166 + \frac{2}{3}\right) \times \frac{1}{1000} = \frac{166}{1000} + \frac{1}{1500}$$

This gives fractions with denominators powers of 10 getting closer and closer to $\frac{1}{6}$:

The fractions $\frac{1}{10}, \frac{16}{100}, \frac{166}{1000}, \dots$ (in other words, the fractions with decimal forms 0.1, 0.16, 0.166, ...) get closer and closer to $\frac{1}{6}$

This we shorten into a decimal form:

$$\frac{1}{6} = 0.1666\dots$$

In finding decimal forms like this, each division of 10, 100, 1000, ... need not be done afresh; we can do one division as a continuation of the previous one.

For example to find the decimal form of $\frac{1}{7}$, we first divide 10 by 7 and write

$$\frac{10}{7} = 1 \frac{3}{7}$$

Next we have to divide 100 by 7. This can be done using the first division as

Recurring decimal

The decimal form of a fraction which cannot be written with a power of 10 as denominator continues indefinitely. But in all these, we can see a block of digits repeating after a stage. There is a reason for this. Consider $\frac{1}{17}$, for example. We calculate the digits of its decimal form by dividing the powers 10, 100, 1000, ... of 10 by 17. In this at every stage, we multiply the remainder got by 10 and divide by 17 again at the next step. Now the remainder at any stage must be one of the numbers from 1 to 16. So after at most 16 divisions, we must get again a remainder obtained earlier. From then on, earlier digits start repeating. If we find the decimal form of $\frac{1}{17}$ using a computer, we can see blocks of 16 digits repeating:

$$\frac{1}{17} = 0.05882352941176470588235294117647\dots$$

But in the decimal form of $\frac{1}{13}$, we see not blocks of 12 digits, but blocks of 6 digits repeating:

$$\frac{1}{13} = 0.076923076923\dots$$

To know more about such decimal forms, see the Wikipedia article:

https://en.wikipedia.org/wiki/Repeating_decimal



A reverse thought

Simon Stevin introduced only decimal forms of fractions with denominators powers of 10. This was extended to other fractions only in the eighteenth century.

There's a reverse question here. If we write a decimal form with digits cyclically repeating, what fraction does it represent?

For example, to see what fraction the decimal form 0.1212... represent, we take that number as x and proceed as follows:

- The fractions $\frac{12}{100}$, $\frac{1212}{10000}$, $\frac{121212}{1000000}$... get closer and closer to x
- Multiplying these by 100, we see that the fractions 12 , $12\frac{12}{100}$, $12\frac{1212}{10000}$, ... get closer and closer to $100x$
- But the numbers 12 , $12 + \frac{12}{100}$, $12 + \frac{1212}{10000}$, ... get closer and closer to $12 + x$, by the first step
- So, we must have $100x = 12 + x$
- This gives, $x = \frac{12}{99} = \frac{4}{33}$

These thoughts are sometimes shortened as

$$x = 0.1212\dots$$

$$100x = 12.1212\dots = 12 + x$$

$$\frac{100}{7} = \left(1 + \frac{3}{7}\right) \times 10 = 10 + \frac{30}{7} = 10 + 4 + \frac{2}{7} = 14\frac{2}{7}$$

And we can continue:

$$\frac{1000}{7} = \frac{100}{7} \times 10 = 140 + \frac{20}{7} = 140 + 2 + \frac{6}{7} = 142\frac{6}{7}$$

The next three divisions we can quickly do. (It's better to use exponents so that we don't lose count of the zeros):

$$\frac{10^4}{7} = 1420 + \frac{60}{7} = 1420 + 8 + \frac{4}{7} = 1428\frac{4}{7}$$

$$\frac{10^5}{7} = 14280 + \frac{40}{7} = 14280 + 5 + \frac{5}{7} = 14285\frac{5}{7}$$

$$\frac{10^6}{7} = 142850 + \frac{50}{7} = 142850 + 7 + \frac{1}{7} = 142857\frac{1}{7}$$

Must we continue? Let's think a bit. The next division is

$$\frac{10^7}{7} = 1428570 + \frac{10}{7}$$

But we have computed $\frac{10}{7}$ at the very first step. Using it,

$$\frac{10^7}{7} = 1428571\frac{3}{7}$$

What if we continue? We find $\frac{30}{7} = 4\frac{2}{7}$, then $\frac{20}{7} = 2\frac{6}{7}$ and so on repeating the earlier divisions in the same order.

These thoughts lead to the decimal form

$$\frac{1}{7} = 0.142857142857\dots$$

with repeating six-digit blocks. (If this is not clear, read once more from the beginning of these operations)

- (1) For each of the fractions below, find fractions with denominators powers of 10 getting closer and closer to it and hence write its decimal



0
1
2
3
4
5
6
7
8
9



form:

(i) $\frac{2}{3}$ (ii) $\frac{5}{6}$ (iii) $\frac{1}{9}$

(2) (i) Using algebra, explain why

$\frac{1}{10}, \frac{11}{100}, \frac{111}{1000}, \dots$ of any number get closer and closer to $\frac{1}{9}$ of that number.

(ii) Use the general principle got above to single-digit numbers to find the decimal forms of $\frac{2}{9}, \frac{4}{9}, \frac{5}{9}, \frac{7}{9}, \frac{8}{9}$

(iii) What can we say in general about decimal forms with a single digit repeating?

(3) (i) Find the decimal form of $\frac{1}{11}$

(ii) Find the decimal forms of $\frac{2}{11}, \frac{3}{11}$

(iii) What is the decimal form of $\frac{10}{11}$?

(4) Write the results of the operations below as decimals:

(i) $0.111\dots + 0.222\dots$

Two forms

What fraction does the decimal 0.4999... represent?

By the definition of such decimal forms, what we have to find is the number to which the fractions $\frac{4}{10}, \frac{49}{100}, \frac{499}{1000} \dots$ get closer and closer to. We can easily see that

$$\frac{1}{2} - \frac{49}{100} = \frac{1}{100}$$

$$\frac{1}{2} - \frac{499}{1000} = \frac{1}{1000}$$

$$\frac{1}{2} - \frac{4999}{10000} = \frac{1}{10000}$$

Thus the fractions listed above get closer and closer to $\frac{1}{2}$. So, by the new extended definition of decimals,

$$\frac{1}{2} = 0.4999\dots$$

We have already seen the old decimal representation of $\frac{1}{2}$ as

$$\frac{1}{2} = \frac{5}{10} = 0.5$$

Similarly, we can see that the fractions with decimal forms 0.19, 0.199, 0.1999, ... get closer and closer to $\frac{1}{5}$. So, apart from the old

decimal form 0.2, the fraction $\frac{1}{5}$ has the new form 0.1999... also. Like this, natural numbers also have new decimal forms:

$$1 = 0.999\dots$$

$$2 = 1.999\dots$$

$$3 = 2.999\dots$$

In general, as we allowed new decimal forms, each old form gets a new form also.



(ii) $0.333... + 0.777...$

(iii) $0.333... \times 0.666...$

(iv) $(0.333...)^2$

(v) $\sqrt{0.444...}$

0 1 2 3 4 5 6 7 8 9

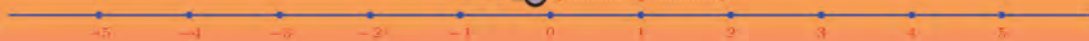

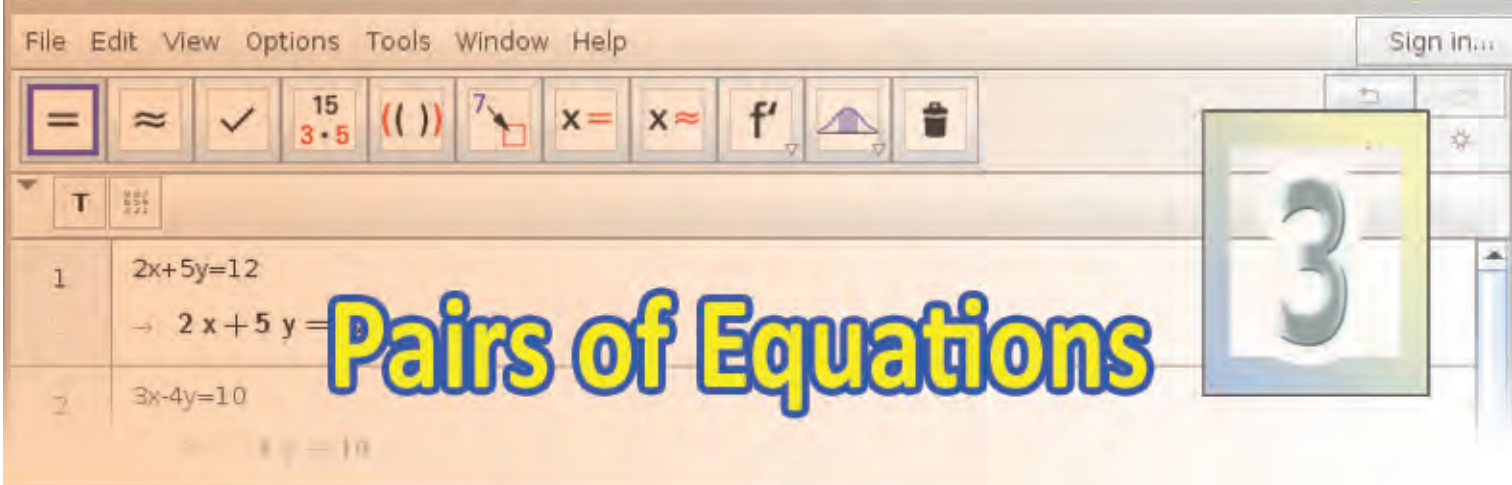

Mental math and algebra

Let's start with a problem:

There are 100 beads in a box, some black and some white; 10 more black than white. How many black, how many white?

We can do this in several ways. Taking out the 10 extra black beads for the time being, we have 90 left in the box, black and white equal. So, 45 of each. Adding the 10 black beads kept apart, black becomes 55 and white remains at 45.

We can do it with algebra also. (Recall the lesson, **Equations** in Class 8).

Taking the number of black beads as x , the number of white beads is $x - 10$ and since there are 100 in all,

$$x + (x - 10) = 100$$

We can extract x from this:

$$2x - 10 = 100$$

$$2x = 110$$

$$x = 55$$

Thus we find the number of black beads as 55; subtracting 10, we get the number of white beads as 45.

There is another way, again using algebra. Taking the number of black beads as x and the number of white beads as y , we can write what we are told as two equations:

$$x + y = 100$$

$$x - y = 10$$

How do we separate x and y from these?



Recall what we learnt about the sum and difference of two numbers, in class 7; adding the sum and difference of two numbers gives twice the larger number. (The section, **Sum and difference** in the lesson, **Unchanging Relations**)

And we also saw that the difference subtracted from the sum gives twice the smaller number.

So in our bead problem,

$$2x = (x + y) + (x - y) = 110$$

$$2y = (x + y) - (x - y) = 90$$

Now we can see that $x = 55$ and $y = 45$.

Here is another problem:

The price of a table and a chair together is 5000 rupees. The price of a table and four chairs is 8000 rupees. What is the price of each?

Let's first see whether we can do this in head. For a table and four chairs, the price increases by 3000 rupees. It's because of the three extra chairs, isn't it? That is, the extra 3000 rupees is the price of three chairs. So, the price of a chair is 1000 rupees and the price of a table is 4000 rupees.

Instead of thinking it out like this, we can start by taking the price of a chair as x rupees; further thinking gives the price of a table as $5000 - x$ rupees and the price of a table and four chairs as $(5000 - x) + 4x$ rupees. This is said to be 8000 rupees. So,

$$(5000 - x) + 4x = 8000$$

From this, we can find out x .

$$5000 + 3x = 8000$$

$$3x = 3000$$

$$x = 1000$$

Thus we find the price of a chair as 1000 rupees; and the price of a table as $5000 - 1000 = 4000$ rupees.

Without thinking anything ahead, we can start by taking the price of a chair as x rupees and the price of a table as y rupees; and then write the given facts as two equations:

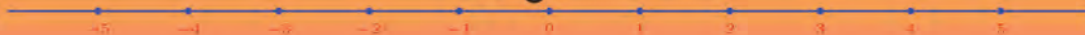

$$x + y = 5000$$

$$4x + y = 8000$$

Then we may write y in terms of x using the first equation:

$$y = 5000 - x$$

Now in the second equation, we can write $5000 - x$ in the place of y :

$$4x + (5000 - x) = 8000$$

This is the earlier equation we got, starting with just the price of a chair as x , isn't it? So we can compute the prices as before.

One more problem:

When we add one to the numerator of a fraction and simplify it, we get $\frac{1}{2}$. When we add one to the denominator instead and simplify it, we get $\frac{1}{3}$. What is this fraction?

This is difficult to do in head. Even by taking just the numerator or denominator as x , we can't go very far. So, let's start by taking the numerator as x and the denominator as y . Then each of the two facts given in the problem can be translated to equations:

$$\frac{x+1}{y} = \frac{1}{2}$$

$$\frac{x}{y+1} = \frac{1}{3}$$

By the first equation, the number y must be double the number $x + 1$. That is

$$2(x + 1) = y$$

From the second equation, we see that the number $y + 1$ is thrice the number x . That is

$$y + 1 = 3x$$

The first equation says the number y is equal to the number $2(x + 1)$. So, we can write $2(x + 1)$ for y in the second equation:

$$3x = 2(x + 1) + 1 = 2x + 3$$

From this, we get $x = 3$; then from the first equation, we can find $y = 2 \times 4 = 8$. Thus $\frac{3}{8}$ is the fraction in the problem.



Do each problem below either in your head, or using an equation with one letter, or two equations with two letters:



- (1) In a rectangle of perimeter one metre, one side is five centimetres longer than the other. What are the lengths of the sides?
- (2) A class has 4 more girls than boys. On a day when only 8 boys were absent, the number of girls was twice that of the boys. How many girls and boys are there in the class?
- (3) A man invested 10000 rupees, split into two schemes, at annual rates of interest 8% and 9%. After one year he got 875 rupees as interest from both. How much did he invest in each?
- (4) A three and a half metre long rod is to be cut into two pieces, one piece is to be bent into a square and the other into an equilateral triangle. The length of their sides must be the same. How should it be cut?
- (5) The distance travelled in t seconds by an object starting with a speed of u metres/second and moving along a straight line with speed increasing at the rate of a metres/second every second is given by $ut + \frac{1}{2}at^2$ metres. An object moving in this manner travels 10 metres in 2 seconds and 28 metres in 4 seconds. With what speed did it start? At what rate does its speed change?

Two equations

See this problem:

The price of 2 pens and 3 notebooks is 40 rupees; and the price of 2 pens and 5 notebooks is 60 rupees. What is the price of a pen? And the price of a notebook?

Recall how we first solved the table and chair problem. Why does the price increase from 40 to 60 here?

Because of 2 more notebooks, right? In other words, the increase of 20 rupees is the price of 2 notebooks. So the price of a notebook is 10 rupees.



0 1 2 3 4 5 6 7 8 9

Now to get the price of 2 pens, we need only subtract the price of the 3 notebooks from 40 rupees, right? That is, $40 - 30 = 10$ rupees. So, the price of a pen is 5 rupees.

Let's see how we can do this by taking the price of a pen as x rupees, the price of a notebook as y rupees and then writing the given facts as equations:

The price of 2 pens and 3 notebooks
is 40 rupees $2x + 3y = 40$

The price of 2 pens and 5 notebooks
is 60 rupees $2x + 5y = 60$

The increase is due to 2 extra notebooks $(2x + 5y) - (2x + 3y) = 2y$

The increase is 20 rupees $60 - 40 = 20$

The price of 2 notebooks is 20 rupees $2y = 20$

The price of a notebook is 10 rupees $y = 10$

The price of 2 pens is 30 rupees
subtracted from 40 rupees $2x = 40 - (3 \times 10) = 10$

The price of a pen is 5 rupees $x = 5$

Look at a slightly different problem:

The price of 3 pencils and 4 pens is 26 rupees; and for 6 pencils and 3 pens, it is 27 rupees. What is the price of each?

Let's first try to do this without algebra. In this, the increase in price is not due to the increase in one thing, as in the first problem. So, it is not as easy as that.

If the number of pencils or pens were the same in both the given facts, we could have done it as before. How about making it so?

Let's write the prices like this:

Pencil	Pen	Price
3	4	26
6	3	27



0 1 2 3 4 5 6 7 8 9





The number of pencils is 3 in the first row and 6 in the second. Can we make it 6 in the first row also?

How about 6 pencils and 8 pens?

	Pencil	Pen	Price
	3	4	26
× 2	6	3	27
	6	8	52

The increase of 25 rupees from the second to the third is due to just 5 pens, isn't it?

So, the price of a pen is 5 rupees. Now from the first row, we can compute the price of 3 pencils as $26 - 20 = 6$ rupees and hence the price of a pencil is 2 rupees.

Now let's write all these thoughts in algebra. Taking the price of a pencil as x rupees and the price of a pen as y rupees, we can write the given facts and the method of calculating the prices, like this:

The price of 3 pencils and 4 pens
is 26 rupees $3x + 4y = 26$

The price of 6 pencils and 3 pens
is 27 rupees $6x + 3y = 27$

The price of 6 pencils and 8 pens
is 52 rupees $6x + 8y = 2(3x + 4y) = 52$

The increase is the price of 5 pens $(6x + 8y) - (6x + 3y) = 5y$

The increase is 25 rupees $5y = 25$

The price of a pen is 5 rupees $y = 5$

The price of 3 pencils is 20 rupees
subtracted from 26 rupees $3x = 26 - (4 \times 5) = 6$

The price of a pencil is 2 rupees $x = 2$

We can shorten this work as follows. First we write the facts given in the problem as equations and label them as equation (1) and equation (2).



0 1 2 3 4 5 6 7 8 9



$$3x + 4y = 26 \quad (1)$$

$$6x + 3y = 27 \quad (2)$$

Equation (1) says, the number $3x + 4y$ is 26; so twice this number is 52.

$$6x + 8y = 52 \quad (3)$$

Now using equation (2) and equation (3), we get

$$(6x + 8y) - (6x + 3y) = 52 - 27$$

Simplifying this, we get

$$5y = 25$$

and this gives $y = 5$. Now taking y as 5 in equation (1), we can compute x :

$$3x + (4 \times 5) = 26$$

$$3x = 26 - 20 = 6$$

$$x = 2$$

Another problem:

Five small buckets and two large buckets of water make 20 litres; two small buckets and three large buckets make only 19 litres. How much water can each bucket hold?

Taking a small bucketful as x litres and a large bucketful as y litres, we can write the given facts as equations:

$$5x + 2y = 20 \quad (1)$$

$$2x + 3y = 19 \quad (2)$$

Proceeding as in the first problem, to get $2x$ in equation

(1) also, we must multiply by $\frac{2}{5}$ or to get $5x$ in equation

(2) also, we must multiply by $\frac{5}{2}$.

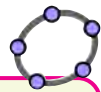

We can use the CAS window in GeoGebra to find the solution of a pair of equations. For example to solve $5x + 2y = 20$, $2x + 3y = 19$, open CAS (View \rightarrow CAS) and type Solve $(\{5x + 2y = 20, 2x + 3y = 19\}, \{x, y\})$

Different Facts

Ramu bought a pencil and a pen for 7 rupees. Aju bought 4 pencils and 4 pens for 28 rupees. They tried to calculate the price of each using these facts. Taking the price of a pencil as x rupees, they used the first fact to get the price of a pen as $7 - x$ rupees. Using this in the second fact, they got

$$4x + 4(7 - x) = 28$$

What did they get on simplification?
 $28 = 28$

What if they had taken the price of a pencil as x rupees and the price of a pen as y rupees?

$$x + y = 7$$

$$4x + 4y = 28$$

If the second equation is written as

$$4(x + y) = 28$$

They would only get

$$x + y = 7$$

again.

In this problem, only one fact is actually given, though stated in two different ways. And using that alone, we cannot find the separate prices.



Math and fact

A rectangle of perimeter 10 metres is to be made with one side 5.5 metres longer than the other. What should be its length and breadth?

Taking the length of the shorter side as x metres, the length of the longer side must be $x + 5.5$ metres. Since the perimeter is to be 10 metres,

$$x + (x + 5.5) = \frac{10}{2} = 5$$

That is,

$$2x + 5.5 = 5$$

which gives

$$2x = -0.5$$

$$x = -0.25$$

But the length of a side of a rectangle cannot be a negative number.

What this means is that we cannot draw a rectangle satisfying these conditions. In this problem, if we take the length of the sides as x and y metres, we get

$$x + y = 5$$

$$y - x = 5.5$$

And we can immediately see that there are no positive numbers satisfying both these conditions. (The sum of two positive numbers cannot be less than their difference, right?)

Thus, we can find the prices. There is a way to do this without fractions. We can make $10x$ in both equations; we need only multiply equation (1) by 2 and equation (2) by 5. The equations change like this:

$$(1) \times 2 : 10x + 4y = 40 \tag{3}$$

$$(2) \times 5 : 10x + 15y = 95 \tag{4}$$

Now subtracting equation (3) from equation (4), we get

$$(4) - (3) : 11y = 55$$

and this gives

$$y = 5$$

Now using this in equation (1), we can calculate x :

$$5x + 10 = 20$$

$$5x = 10$$

$$x = 2$$

Thus we see that the small bucket holds 2 litres and the large bucket, 5 litres.



- (1) Raju bought seven notebooks of two hundred pages and five of hundred pages, for 107 rupees. Joseph bought five notebooks of two hundred pages and seven of hundred pages, for 97 rupees. What is the price of each kind of notebook?
- (2) Four times a number and three times another number added together make 43. Two times the second number, subtracted from three times the first gives 11. What are the numbers?
- (3) The sum of the digits of a two-digit number is 11. The number got by interchanging the digits is 27 more than the original number. What is the number?



0 1 2 3 4 5 6 7 8 9

- (4) Four years ago, Rahim's age was three times Ramu's age. After two years, it would just be double. What are their ages now?
- (5) If the length of a rectangle is increased by 5 metres and the breadth decreased by 3 metres, the area would decrease by 5 square metres. If the length is increased by 3 metres and breadth increased by 2 metres, the area would increase by 50 square metres. What are the length and breadth?

Some other equations

See this problem:

Of two squares, the sides of the larger are 5 centimetres longer than those of the smaller and the area of the larger is 55 square centimetres more. What is the length of the sides of each?

Taking the length of a side of the larger square as x centimetres and that of the smaller as y centimetres, we can write the facts given as two equations:

$$\begin{aligned}x - y &= 5 \\x^2 - y^2 &= 55\end{aligned}$$

What do we do next?

Recall that $x^2 - y^2 = (x + y)(x - y)$; this we can write as

$$x + y = \frac{x^2 - y^2}{x - y}$$

So in our problem,

$$x + y = \frac{55}{5} = 11$$

Now we have the sum $x + y = 11$ and the difference, $x - y = 5$. We can calculate the numbers as

$$\begin{aligned}x &= \frac{1}{2}(11 + 5) = 8 \\y &= \frac{1}{2}(11 - 5) = 3\end{aligned}$$

Thus the lengths of the sides of the squares are 8 centimetres and 3 centimetres.

Another problem:

The perimeter of a rectangle is 10 metres and its area is $5\frac{1}{4}$ square metres. What are the lengths of its sides?



Taking the lengths of the sides as x metres and y metres, perimeter is $2(x+y)$ metres and area is xy square metres. So the facts given can be written as the equations,

$$x + y = 5$$

$$xy = 5\frac{1}{4}$$

What next? Can we find $x - y$ from these?

Recall that $(x + y)^2 - (x - y)^2 = 4xy$. We can write this as

$$(x - y)^2 = (x + y)^2 - 4xy$$

So in our problem

$$(x - y)^2 = 5^2 - \left(4 \times 5\frac{1}{4}\right) = 25 - 21 = 4$$

This gives $x - y = 2$. Together with $x + y = 5$, we can find $x = 3\frac{1}{2}$, $y = 1\frac{1}{2}$

Thus the lengths of the sides of the rectangle are $3\frac{1}{2}$ metres and $1\frac{1}{2}$ metres.



- (1) A 10 metre long rope is to be cut into two pieces and a square is to be made using each. The difference in the areas enclosed must be $1\frac{1}{4}$ square metres. How should it be cut?
- (2) The length of a rectangle is 1 metre more than its breadth. Its area is $3\frac{3}{4}$ square metres. What are its length and breadth?
- (3) The hypotenuse of a right triangle is $6\frac{1}{2}$ centimetres and its area is $7\frac{1}{2}$ square centimetres. Calculate the lengths of its perpendicular sides.

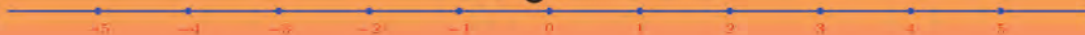

New Numbers

Lengths and numbers

See the picture:

A small square and a larger one drawn on its diagonal.

We have seen in Class 7 that the area of the large square made thus is twice the area of the smaller one, remember?

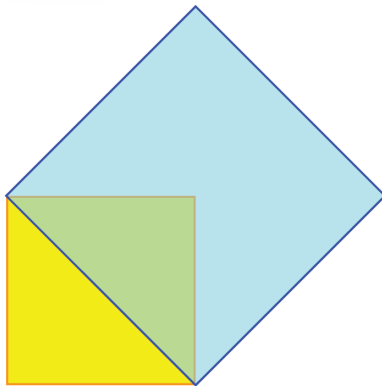
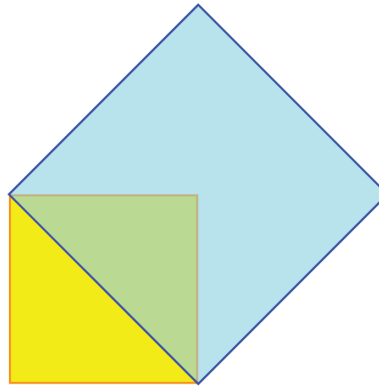

That is, if the sides of the small square are one metre long then the area of the large square is two square metres.

What is the length of its sides?

It is longer than one metre anyway; and shorter than two metres (how come?)

It may be some fraction between one and two, but then the area of the square being two metres, the square of this fraction must be two.

What fraction squared gives two?

One and a half perhaps?

$$\left(1\frac{1}{2}\right)^2 = \left(1+\frac{1}{2}\right)^2 = 1 + 1 + \frac{1}{4} = 2\frac{1}{4}$$



So, one and a half is a bit too large. One and a quarter?

$$\left(1\frac{1}{4}\right)^2 = 1 + \frac{1}{2} + \frac{1}{16} = 1\frac{9}{16}$$

But now it is smaller than two. One and a third?

$$\left(1\frac{1}{3}\right)^2 = 1 + \frac{2}{3} + \frac{1}{9} = 1\frac{7}{9}$$

It also is smaller, but better than one and a quarter.

Like this we can try many fractions; and we can find fractions whose squares are closer and closer to 2. But never do we get a fraction whose square is exactly 2. We can even prove this, using algebra. (See the appendix at the end of this chapter).

Now let's record this fact.

The square of any fraction is not 2.

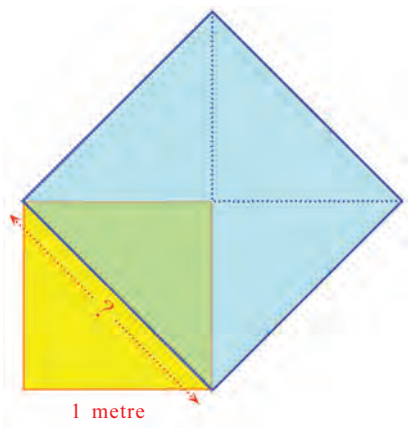

So what happens to our geometric problem?

If the diagonal of a square of side one metre is a fractional multiple of one metre, then the square of that fraction must be two (we have seen in Class 6 that the area of a square is the square of its side, even when the length of a side is a fractional multiple of the unit). But there is no fraction whose square is 2. So, what can we say?

The diagonal of a square of side 1 cannot be expressed as a fraction.

We have several such lengths which cannot be expressed as a natural number or fraction. For example, see this picture.

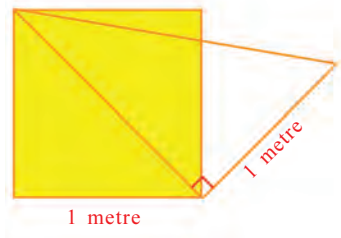

What is the length of hypotenuse of the right triangle drawn on the diagonal of the square? Let's draw squares on all its sides:



0 1 2 3 4 5 6 7 8 9

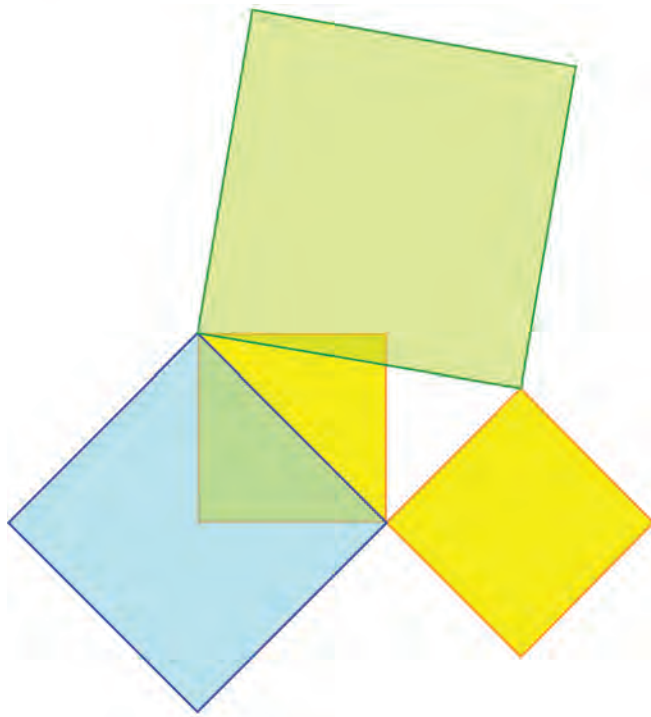

By Pythagoras theorem the area of the green square on the hypotenuse of our right triangle is $1 + 2 = 3$ square metres. So, if its length is a fractional multiple of 1 metre, then the square of this fraction must be 3.

Just as we prove that the square of any fraction cannot be 2, we can prove that the square of any fraction cannot be 3 either. So, the length of the hypotenuse of this right triangle also cannot be expressed as a fraction.

Let's look at another example: Suppose we want to make a cube of volume 2 cubic centimetres. What should be the length of its sides? We can show that the cube (third power) of any fraction is not 2. So, the length of a side of this cube cannot also be expressed as a fraction.

Thus, there are many instances where we need lengths which cannot be expressed as fractions.

Origin of numbers

Measure everything and make it a number; through such numbers and relations between them try to understand the world – this is the basic function of mathematics.

Depending on the nature of the things measured, different kinds of numbers need to be created. During the age when men gathered food directly from nature, they needed numbers only for counting – the number of men in a group, the number of cattle in a herd and so on. In other words, only natural numbers were needed at that time.

Later around five thousand BC, as men settled along river banks and started large scale agriculture, they needed to measure all kinds of lengths and areas to mark land and build houses. The concept of fractions arose in this period. New numbers were needed when it was realised that not all measurements could be expressed as fractions.

Still later other kinds of numbers like negative numbers and complex numbers were created for mathematical convenience, rather than physical necessities. That such numbers were also found useful in science like physics is another matter.



Measures and numbers

We have to make a new kind of number to denote measures which cannot be expressed as fractions. Let's take our first example. How do we denote the length of the diagonal of a square of side 1 (metre or centimetre or whatever)?

Crumbling beliefs

During the sixth century BC, Pythagoras and his disciples believed that all measures could be compared using natural numbers. More precisely, they thought that any two measures could be compared by ratios of natural numbers. But the ratio of the diagonal of a square to its side cannot be expressed as a ratio of natural numbers. For if this ratio could be expressed as $a : b$, where a and b are natural numbers, then the diagonal would be $\frac{a}{b}$ times the side, so that the square on the diagonal would be $\frac{a^2}{b^2}$ times the square on the side, which would give $\frac{a^2}{b^2} = 2$. And we have seen that this is impossible.

It is believed that this was discovered by Hippasus, who was a disciple of Pythagoras.

Measures like the diagonal and side of a square, which cannot be compared using ratios of natural numbers, are called *incommensurable magnitudes*.

We can put the question like this: how do we denote the side of a square of area 2?

For a square with length of a side denoted by a natural number or a fraction, this length is the square root of the area. For example, the length of a side of a square of area 4 is $\sqrt{4} = 2$; if the area is $2\frac{1}{4}$, then the length of a side is $\sqrt{2\frac{1}{4}} = 1\frac{1}{2}$.

Like this, we write the length of a side of a square of area 2 as $\sqrt{2}$:

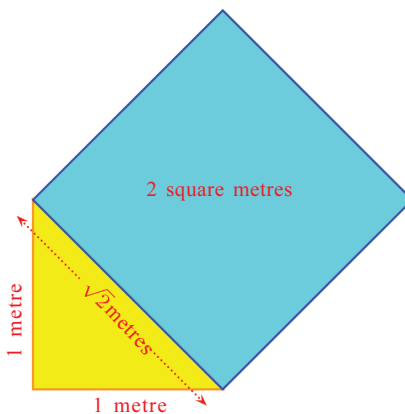

Just giving a symbol to denote the length doesn't solve our problem. To know its size, we must compare it with known lengths. We do this by finding fractions closer and closer to this length. If we mark such lengths along the diagonal, the squares with sides of these lengths get closer and closer to the square on the diagonal.



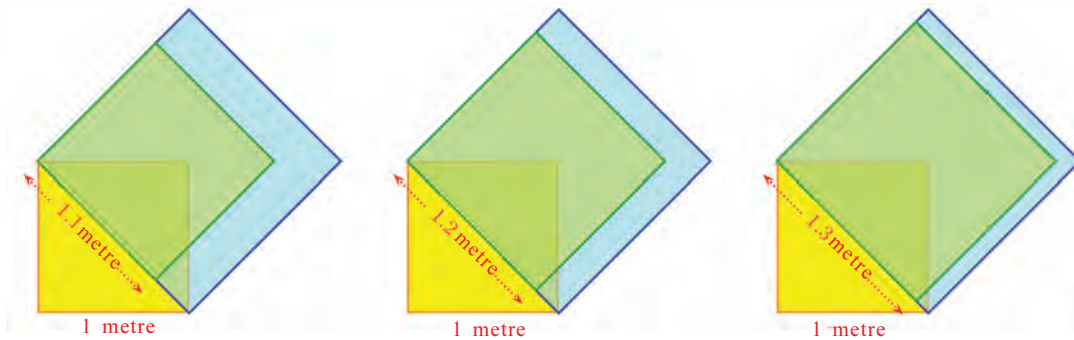

In terms of numbers alone, this means the (numerical) squares of the fractions expressing the lengths of the sides of these (geometric) squares get closer and closer to 2.

To find such numbers, it is more convenient to use the decimal forms of fractions. Computing first the squares of the fractions 1.1, 1.2, 1.3, ... we find

$$1.4^2 = 1.96$$

$$1.5^2 = 2.25$$

So, taking up to tenths, we get

$$1.4^2 < 2 < 1.5^2$$

Now computing the squares of the numbers 1.41, 1.42, 1.43, between 1.4 and 1.5, we find

$$1.41^2 = 1.9881; \quad 1.42^2 = 2.0164$$

So, taking up to hundredths, we get

$$1.41^2 < 2 < 1.42^2$$

Continuing like this, we find

1.4^2	=	1.96	1.5^2	=	2.25
1.41^2	=	1.9881	1.42^2	=	2.0164
1.414^2	=	1.999396	1.415^2	=	2.002225
1.4142^2	=	1.99996164	1.4143^2	=	2.00024449
1.41421^2	=	1.9999899241	1.41422^2	=	2.0000182084

and so on. That is, up to five decimal places,

$$1.41421^2 < 2 < 1.41422^2$$

We can also note that

$$2 - 1.41421^2 = 0.0000100759 < 0.00002$$



B5XSDP



Summarising, we have found this:

The squares of the fractions continuing as

$$\frac{14}{10}, \frac{141}{100}, \frac{1414}{1000}, \frac{14142}{10000}, \frac{141421}{100000}, \dots \text{ get closer and closer to } 2.$$

We write this fact in short like this:

$$\sqrt{2} = 1.41421 \dots$$

So, we can say that the number $\sqrt{2}$ is 1.4 up to one decimal place, 1.41 upto two decimal places, and so on. We write

$$\sqrt{2} \approx 1.4$$

$$\sqrt{2} \approx 1.41$$

and so on. The symbol \approx in this means approximately (nearly) equal.

Like this, the length of the sides of a square of area 3 is said to be $\sqrt{3}$.

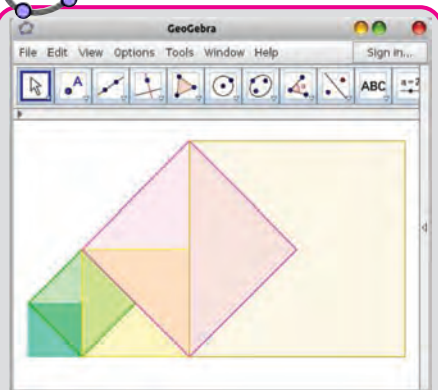

In the picture, a side of the smallest square is 1 centimetre. Calculate the area and a side of the largest square. Draw this picture in GeoGebra, using **Regular Polygon**. Use **Area** to find the area of each square. Which of the squares have a fraction as the length of a side?

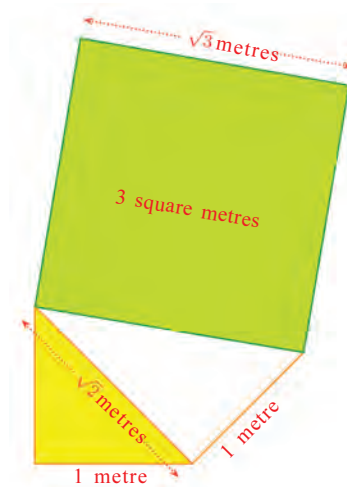

Making computations as before, we can see that the squares of the fractions 1.7, 1.73, 1.732... get closer and closer to 3. We shorten this by writing $\sqrt{3} = 1.73205\dots$

In general, for any positive number, the length of a side of a square of area x is written \sqrt{x} . In some cases, \sqrt{x} would be a natural number or fraction; in other cases, we compute fractions whose squares get closer and closer to x and write \sqrt{x} in decimal form.

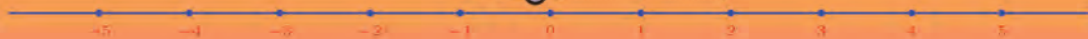

0 1 2 3 4 5 6 7 8 9



- (1) In the picture, the square on the hypotenuse of the top most right triangle is drawn. Calculate the area and the length of a side of the square.

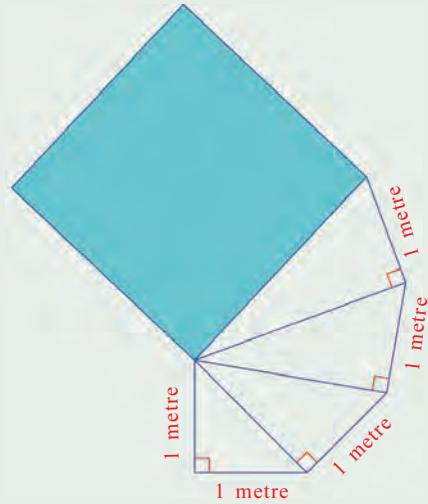

- (2) A square is drawn on the altitude of an equilateral triangle of side 2 metres.
- What is the area of the square?
 - What is the altitude of the triangle?



- iii) What are the lengths of the other two sides of the triangle shown below?



- We have seen in Class 8 that any odd number can be written as the difference of two perfect squares. (The lesson, **Identities**) Using this, draw squares of areas 7 and 11 square centimetres.
- Explain two different methods of drawing a square of area 13 square centimetres.
- Find three fractions larger than $\sqrt{2}$ and less than $\sqrt{3}$.





Addition and subtraction

What is the area of a right triangle with lengths of perpendicular sides 1 metre?

And the perimeter?

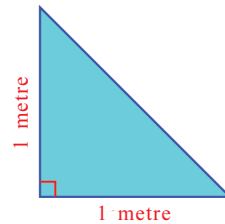

A different ratio

B is the centre of the circle in the picture.

$AB : BC = \sqrt{2} : 1$

The length of its hypotenuse is $\sqrt{2}$ metres.

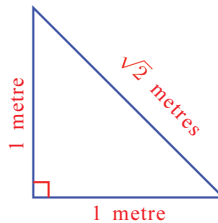

So, to get the perimeter, we must add 2 metres and $\sqrt{2}$ metres. We write it as $2 + \sqrt{2}$ metres.

The fractions which are approximately equal to $\sqrt{2}$ continue as 1.4, 1.41, 1.414, ... So the fractions approximately $2 + \sqrt{2}$ are got by adding 2 to these; that 3.4, 3.41, 3.414, ...

In this problem, if we need only measurements correct to a centimetre, we can take the perimeter as 3.41 metres. And if we want accuracy up to millimetres, we take it as 3.414 metres.

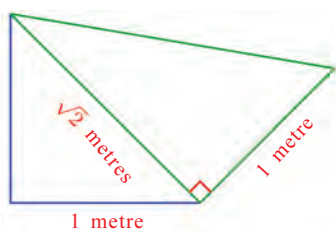

Suppose we draw another right triangle as in the picture, with the hypotenuse of our first triangle as base. We have seen that its third side is $\sqrt{3}$ metres.

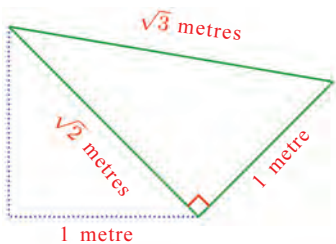

We can write its perimeter as $1 + \sqrt{2} + \sqrt{3}$ metres. To get fractions approximately equal to $\sqrt{2} + \sqrt{3}$, we add approximately equal fractions of each.



0 1 2 3 4 5 6 7 8 9

$\sqrt{2}$:	1.4	1.41	1.414
$\sqrt{3}$:	1.7	1.73	1.732
<hr/>				
$\sqrt{2} + \sqrt{3}$:	3.1	3.14	3.146

Adding 1 to these, we get fractions approximately equal to $1 + \sqrt{2} + \sqrt{3}$.

Thus the perimeter of the new triangle, correct to a millimetre is 4.146 metres.

How much more is the perimeter of this triangle, than the perimeter of the first one? We can say, approximately $4.146 - 3.414 = 0.732$ metre.

Or we can compute it like this:

$$(1 + \sqrt{2} + \sqrt{3}) - (2 + \sqrt{2}) = 1 + \sqrt{3} - 2 = \sqrt{3} - 1 \approx 0.732$$

Now we draw one more triangle on top of this.

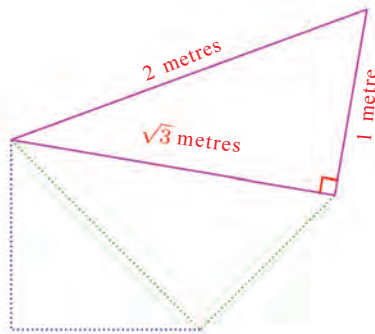

How much more is its perimeter, than that of the second triangle?

The perimeter of this new triangle is $2 + 1 + \sqrt{3} = 3 + \sqrt{3}$ metres. We can calculate the increase in perimeter without calculating fractions approximately equal to its perimeter.

The perimeter of the second triangle is $1 + \sqrt{2} + \sqrt{3}$ metres. So, the increase in perimeter is

$$(3 + \sqrt{3}) - (1 + \sqrt{2} + \sqrt{3}) = 2 - \sqrt{2}$$

We can compute this upto three decimal places as

$$2 - 1.414 = 0.586$$

So, the perimeter is approximately 586 millimetres (or 58.6 centimetres) more.



(1) The hypotenuse of a right triangle is $1\frac{1}{2}$ metres and another side is $\frac{1}{2}$ metre. Calculate its perimeter correct to a centimetre.

(2) The picture shows an equilateral triangle cut into halves by a line through a vertex.

- i) What is the perimeter of a part?
(See the second problem at the end of the previous section)
- ii) How much less than the perimeter of the whole triangle is this?

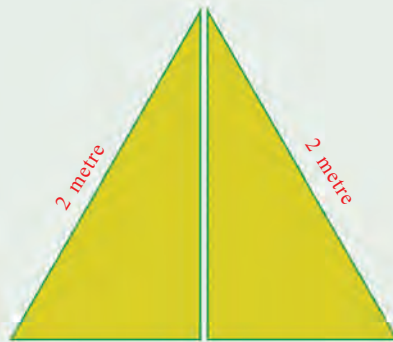

(3) Calculate the perimeter of the triangle shown below.

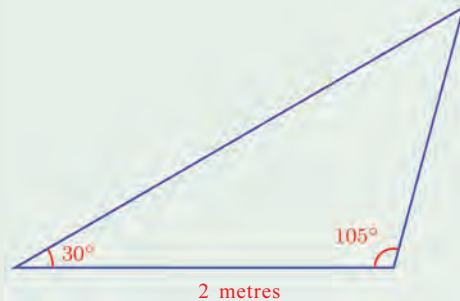

(4) We have seen how we can draw a series of right triangles as in the picture.

- i) What are the lengths of the sides of the tenth triangle, drawn like this?
- ii) How much more is the perimeter of the tenth triangle than the perimeter of the ninth triangle?
- (iii) How do we write in algebra, the difference in perimeter of the n^{th} triangle and that of the triangle just before it?

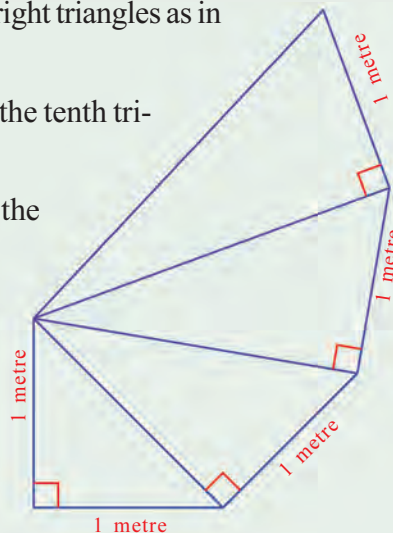

(5) What is the hypotenuse of the right triangle with perpendicular sides $\sqrt{2}$ centimetres and $\sqrt{3}$ centimetres? How much larger than the hypotenuse is the sum of the perpendicular sides?

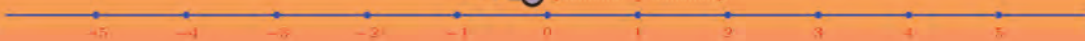

0 1 2 3 4 5 6 7 8 9

Multiplication

We have seen this picture many times. What is the perimeter of the square in this?

We know that the length of each of its sides is $\sqrt{2}$ metres. So to get the perimeter, we must calculate four times this.

As with other numbers, we write 4 times $\sqrt{2}$ as $4 \times \sqrt{2}$. Usually we write this without the multiplication sign, as $4\sqrt{2}$.

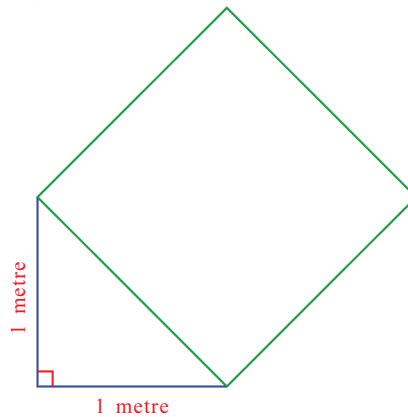

To get fractions approximately equal to this, we find four times the fractions approximately equal to $\sqrt{2}$.

So the perimeter of our square, correct to a millimetre, is

$$4 \times 1.414 = 5.656 \text{ metres}$$

Similarly, we write half of $\sqrt{2}$ as $\frac{1}{2}\sqrt{2}$.

By taking half of fractions approximately equal to $\sqrt{2}$, we get fractions approximately equal to $\frac{1}{2}\sqrt{2}$.

That is $\frac{1}{2}\sqrt{2} = 0.7071 \dots$

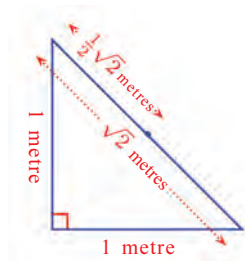

Now see these pictures:

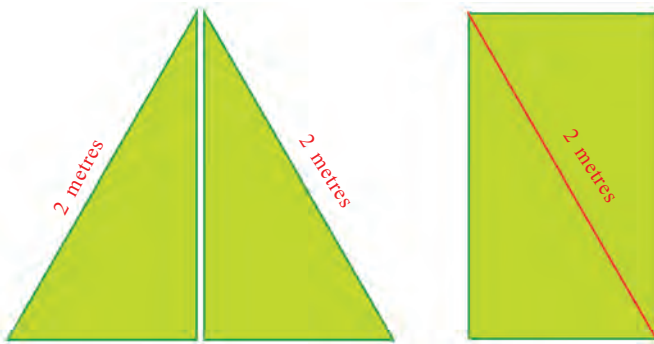

An equilateral triangle is cut into halves and the pieces rearranged to make a rectangle.

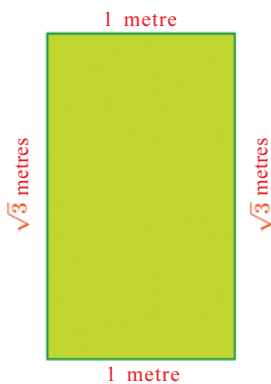

What is the perimeter of this rectangle?

Since the right triangles are equal, the base of each is 1 metre and we have seen in an earlier problem that the height is $\sqrt{3}$ metres.

So, the perimeter is $2\sqrt{3} + 2$ metres.

We can calculate fractions approximately equal to this number as below:

$$\sqrt{3} : 1.7 \quad 1.73 \quad 1.732 \dots$$

$$2\sqrt{3} : 3.4 \quad 3.46 \quad 3.464 \dots$$

$$2\sqrt{3} + 2 : 5.4 \quad 5.46 \quad 5.464 \dots$$

As with other numbers, is $2\sqrt{3} + 2$ equal to $2(\sqrt{3} + 1)$?

We can compute fractions approximately equal to the second number like this:

$$\sqrt{3} : 1.7 \quad 1.73 \quad 1.732 \dots$$

$$\sqrt{3} + 1 : 2.7 \quad 2.73 \quad 2.732 \dots$$

$$2(\sqrt{3} + 1) : 5.4 \quad 5.46 \quad 5.464 \dots$$

Thus the fractions approximating $2\sqrt{3} + 2$ and $2(\sqrt{3} + 1)$ are the same. So,

$$2\sqrt{3} + 2 = 2(\sqrt{3} + 1)$$

Now let's see what the area of this rectangle is.

If the lengths of sides are fractions, then the area is their product.

Here also, is the area $1 \times \sqrt{3} = \sqrt{3}$ square metres, which is the product of the sides?

To see this, let's draw rectangles of one side 1 metre and the other side fractional lengths approximately equal to $\sqrt{3}$ metres, within our rectangle (as we have done sometime before).

0 1 2 3 4 5 6 7 8 9

1 2 3 4 5 6 7 8 9 10 11 12 13 14 15



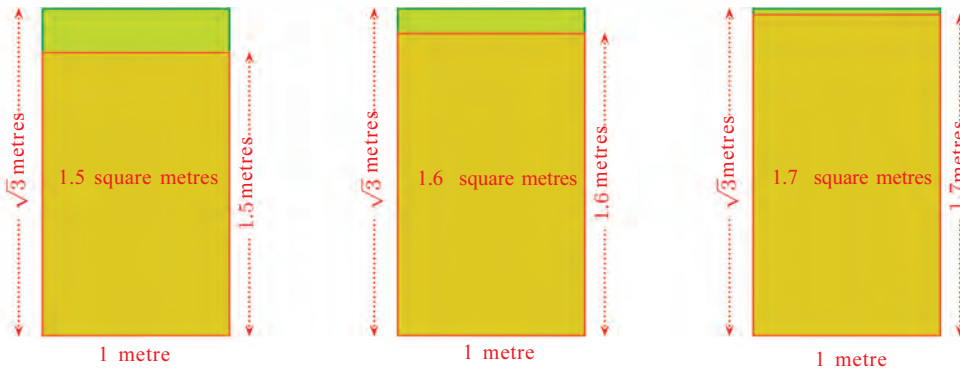

As we continue taking the heights of the inner rectangles as 1.73, 1.732 ... metres, their areas are also the same number in square metres.

Thus the area of a rectangle of sides 1 metre and $\sqrt{3}$ metres is indeed $\sqrt{3}$ square metres.

Now, what if the lengths of the sides are $\sqrt{3}$ and $\sqrt{2}$? We denote the area as $\sqrt{3} \times \sqrt{2}$.

To explain it in terms of numbers, we multiply fractions approximately equal to $\sqrt{3}$ and $\sqrt{2}$ in order and take as many decimal places as we need:

$$\sqrt{3} \quad : \quad 1.7 \quad 1.73 \quad 1.732 \quad 1.7320 \quad 1.73205 \dots$$

$$\sqrt{2} \quad : \quad 1.4 \quad 1.41 \quad 1.414 \quad 1.4142 \quad 1.41421 \dots$$

$$\sqrt{3} \times \sqrt{2} : \quad 2.4 \quad 2.44 \quad 2.449 \quad 2.4494 \quad 2.44948 \dots$$

$$\sqrt{3} \times \sqrt{2} = 2.44948 \dots$$

We note another thing here. The numbers 1.4^2 , 1.41^2 , 1.414^2 , 1.4142^2 , ... get closer and closer to 2. (The very meaning of writing $\sqrt{2} = 1.41421 \dots$ is this).

And the numbers 1.7^2 , 1.73^2 , 1.732^2 , 1.7320^2 , 1.73205^2 , ... get closer and closer to 3.

So, the product of these squares must get closer and closer to 6, right?

And the product of squares of fractions is the square of the product.



Decimal Math

In shortening numbers in decimal form up to a definite place, if the digit in the next place is more than 5, we increase the digit in the desired place by 1. For example, $1.7 \times 1.4 = 2.38$; and its approximation upto the first decimal place is 2.4.



Thus we have

$$1.7^2 \times 1.4^2 = (1.7 \times 1.4)^2$$

$$1.73^2 \times 1.41^2 = (1.73 \times 1.41)^2$$

$$1.732^2 \times 1.414^2 = (1.732 \times 1.414)^2$$

and so on. In this, the products 1.7×1.4 , 1.73×1.41 and so on are already calculated in the last row of our table. So, we can write fractions approximating 2, 3 and 6 like this:

3	:	1.7^2	1.73^2	1.732^2	1.7320^2	$1.73205^2 \dots$
2	:	1.4^2	1.41^2	1.414^2	1.4142^2	$1.41421^2 \dots$
6	:	2.4^2	2.44^2	2.449^2	2.4494^2	$2.44948^2 \dots$

What does the last row of this mean?

The squares of the numbers 2.4, 2.44, 2.449, 2.4494, 2.44948, ... get closer and closer to 6.

By our definition of new numbers, we write this as

$$\sqrt{6} = 2.44948 \dots$$

We have seen that $\sqrt{3} \times \sqrt{2}$ is also equal to this. So we get,

$$\sqrt{3} \times \sqrt{2} = \sqrt{6}$$

We can see that for numbers other than 2 and 3 also, the product of square roots is equal to the square root of the product (we have already seen in Class 7 that this is so in the case where the square roots are natural numbers or fractions)

$$\sqrt{x} \times \sqrt{y} = \sqrt{xy}, \text{ for any positive numbers } x \text{ and } y.$$

We can use this to simplify certain square roots. For example, let's compute the hypotenuse of a right triangle of perpendicular sides 3 centimetres each. By Pythagoras Theorem, the area of the square on the hypotenuse is $3^2 + 3^2 = 18$ square centimetres. So its length is $\sqrt{18}$ centimetres.

Now writing 18 as 9×2 we get.

$$\sqrt{18} = \sqrt{9 \times 2} = \sqrt{9} \times \sqrt{2} = 3\sqrt{2}$$



0 1 2 3 4 5 6 7 8 9



We can see this geometrically also:

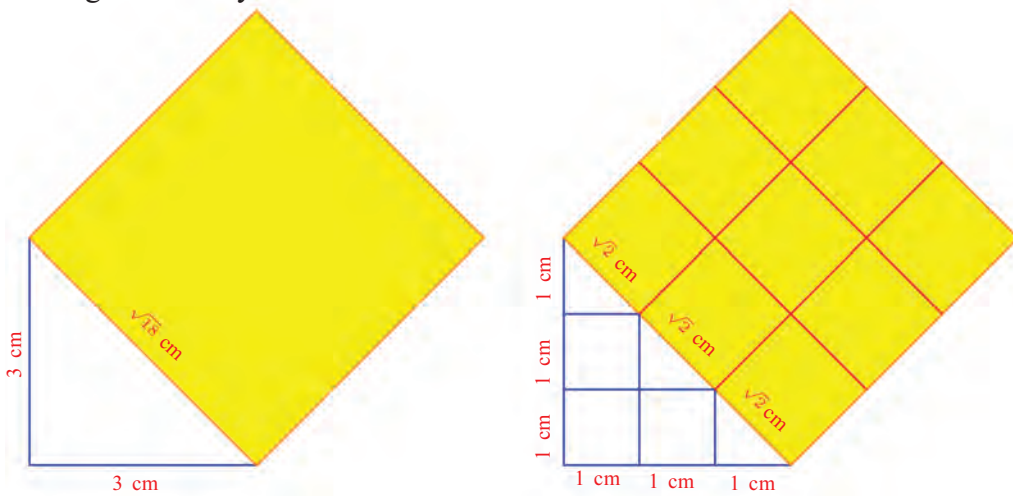

- (1) Of four equal equilateral triangles, two cut vertically into halves and two whole are put together to make a rectangle:



If a side of the equilateral triangle is 1 metre, what is the area and the perimeter of the rectangle?

- (2) A square and an equilateral triangle of sides twice as long are cut and the pieces are rearranged to form a trapezium, as shown below:



If a side of the square is 2 centimetres, what are the perimeter and area of the trapezium?



0 1 2 3 4 5 6 7 8 9



- (3) Calculate the perimeter and area of the triangle in the picture.

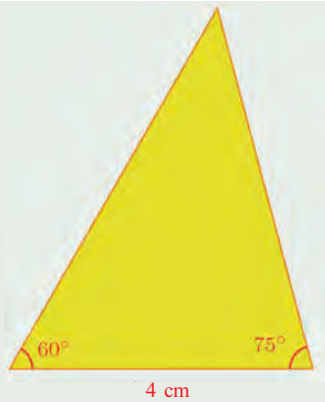

- (5) From the pairs of numbers given below, pick out those whose product is a natural number or a fraction.

- i) $\sqrt{3}, \sqrt{12}$ ii) $\sqrt{3}, \sqrt{1.2}$ iii) $\sqrt{5}, \sqrt{8}$
 iv) $\sqrt{0.5}, \sqrt{8}$ v) $\sqrt{7\frac{1}{2}}, \sqrt{3\frac{1}{3}}$

Division

We can write the product $2 \times 3 = 6$ as the division $\frac{6}{2} = 3$ or $\frac{6}{3} = 2$. Similarly, the product $\sqrt{2} \times \sqrt{3} = \sqrt{6}$ can also be written as divisions:

$$\frac{\sqrt{6}}{\sqrt{2}} = \sqrt{3} \quad \frac{\sqrt{6}}{\sqrt{3}} = \sqrt{2}$$

In general, for any natural number or fraction x, y , we can write the product as $x \times y = z$ and the division as $\frac{z}{x} = y$ and $\frac{z}{y} = x$.

Similarly

For any positive numbers x, y the product

$$\sqrt{x} \times \sqrt{y} = \sqrt{z}$$

can be written as the divisions

$$\frac{\sqrt{z}}{\sqrt{x}} = \sqrt{y} \quad \text{and} \quad \frac{\sqrt{z}}{\sqrt{y}} = \sqrt{x}$$



0 1 2 3 4 5 6 7 8 9

Now since $\frac{6}{2} = 3$ and $\frac{6}{3} = 2$, we have

$$\sqrt{\frac{6}{2}} = \sqrt{3} \quad \sqrt{\frac{6}{3}} = \sqrt{2}$$

And we have seen earlier that

$$\frac{\sqrt{6}}{\sqrt{2}} = \sqrt{3} \quad \frac{\sqrt{6}}{\sqrt{3}} = \sqrt{2}$$

From these pairs of equations, we get

$$\frac{\sqrt{6}}{\sqrt{2}} = \sqrt{3} \quad \frac{\sqrt{6}}{\sqrt{3}} = \sqrt{2}$$

Similarly, from $3 \times \frac{2}{3} = 2$, we get

$$\sqrt{3} \times \sqrt{\frac{2}{3}} = \sqrt{3 \times \frac{2}{3}} = \sqrt{2}$$

and then we can write this product as the division

$$\sqrt{\frac{2}{3}} = \frac{\sqrt{2}}{\sqrt{3}}$$

Now let's see how such square roots are computed.

For example, to compute $\sqrt{\frac{1}{2}}$, we first write

$$\sqrt{\frac{1}{2}} = \frac{1}{\sqrt{2}}$$

Then we can take a fraction approximately equal to $\frac{1}{\sqrt{2}}$, divide 1 by this number and thus get a fraction approximately equal to $\frac{1}{\sqrt{2}}$.

$$\frac{1}{\sqrt{2}} \approx \frac{1}{1.414} = 0.707 \text{ (You can use a calculator).}$$

There is an easier way. Since $\frac{1}{2} = \frac{2}{4}$ we can proceed like this:

$$\sqrt{\frac{1}{2}} = \sqrt{\frac{2}{4}} = \frac{\sqrt{2}}{\sqrt{4}} = \frac{\sqrt{2}}{2}$$

Now we easily get

$$\frac{\sqrt{2}}{2} \approx \frac{1.414}{2} = 0.707 \text{ (You don't need a calculator for this!)}$$



We can see $\frac{\sqrt{2}}{2} = \sqrt{\frac{1}{2}}$, geometrically also:

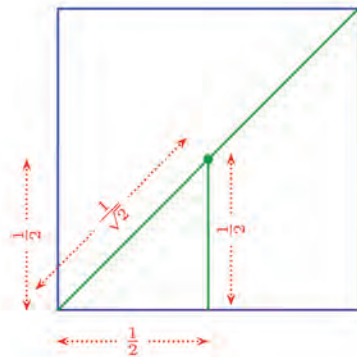
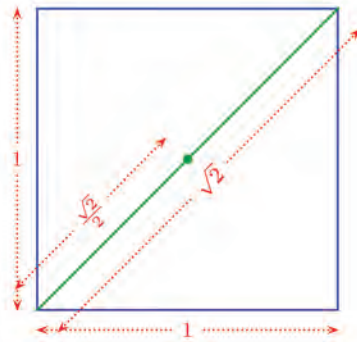

Can you compute $\sqrt{\frac{1}{3}}$ like this?



- (1) Calculate the length of the sides of the equilateral triangle on the below, correct to a millimetre.

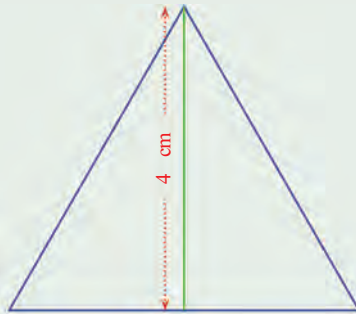

- (2) Prove that $(\sqrt{2} + 1)(\sqrt{2} - 1) = 1$. Use this to compute $\frac{1}{\sqrt{2} - 1}$ correct to two decimal places.
- (3) Compute $\frac{1}{\sqrt{2} + 1}$ correct to two decimal places.
- (4) Simplify $(\sqrt{3} - \sqrt{2})(\sqrt{3} + \sqrt{2})$. Use this to compute $\frac{1}{\sqrt{3} - \sqrt{2}}$ and $\frac{1}{\sqrt{3} + \sqrt{2}}$ correct to two decimal places.



0 1 2 3 4 5 6 7 8 9

- (5) Prove that $\sqrt{2\frac{2}{3}} = 2\sqrt{\frac{2}{3}}$ and $\sqrt{3\frac{3}{8}} = 3\sqrt{\frac{3}{8}}$. Can you find other numbers like this?
- (6) All red triangles in the picture are equilateral.

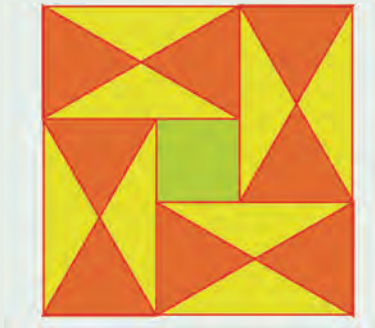

What is the ratio of the sides of the outer and inner squares?



Appendix

To prove that the square of any fraction is not 2, what we do is to show that any effort to find such a fraction will fail. Every fraction has many forms, right? There is one simplest form in which the numerator and denominator have no common factor. To try to find a fraction whose square is 2, let's see how the numerator and denominator of the simplest form of such a fraction should be. Let's write them as p and q . Then $\frac{p^2}{q^2} = 2$; p and q should have no common factor.

We can write the equation

$$\frac{p^2}{q^2} = 2$$

as

$$p^2 = 2q^2$$

So, p^2 should be an even number (since $2q^2$ is even). Since the squares of odd numbers are odd (and squares of even numbers are even), this means p itself should be an even number. Now since p and q have no common factors, q should be odd.

Again, since p is an even number, we can write it as $2k$. Then the equation $p^2 = 2q^2$ becomes $4k^2 = 2q^2$. From this, we get

$$q^2 = 2k^2$$

Hence q^2 is an even number, and as in the case of p , it follows that q itself is an even number. We first noted that q should be an odd number, right? And now we see that it should be an even number. So, if the square of some fraction is 2, then in its simplest form, the denominator should be both even and odd. It is impossible, isn't it? In other words, there is no fraction whose square is 2.

Circles



Circles and lines

Use a bangle or a small round lid to draw a circle in your notebook. How do we find its centre?

The distance from any point on the circle to the centre is the same.

So, if we mark two points on the circle, the centre is a point at the same distance from both. How do you find such a point?

In this picture, the point is above the centre.

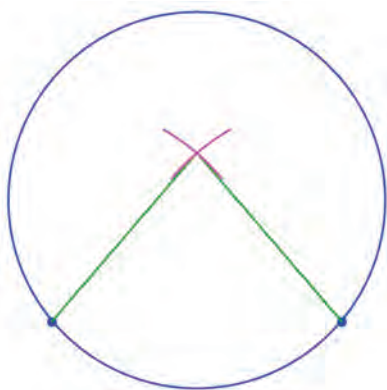
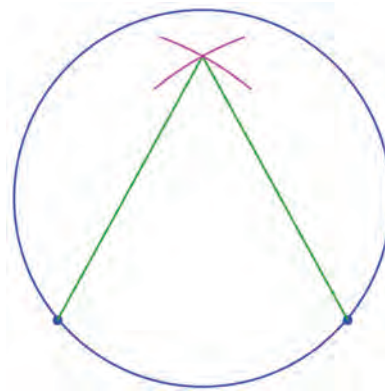

It is not right in this picture also. Instead of proceeding by trial and error like this, let's stop and think a little bit about the problem.

There are so many points at the same distance from the two points marked on the circle. How do we decide which among them is the centre?



All the points which are at the same distance from two fixed points are the third vertices of isosceles triangles with the line joining these two points as base.

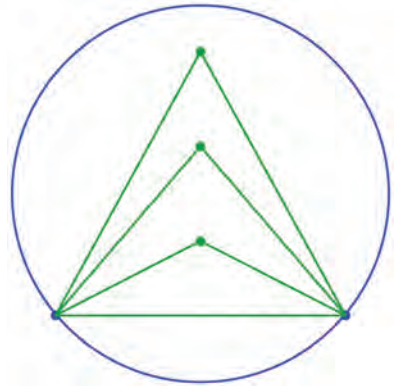

And we know that such points lie along the perpendicular bisector of the base (The lesson, **Equal Triangles** in the Class 8 textbook).

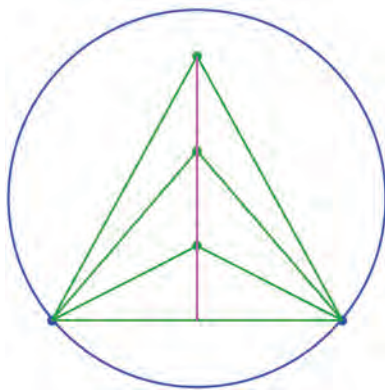

So, the centre we seek is on the perpendicular bisector of the line joining the points we have marked on the circle.

But this doesn't tell us where on the line the centre is.

If we mark two other points on the circle, the centre must be on the perpendicular bisector of the line joining these two points also. Since it must be on both lines, it must be their point of intersection.

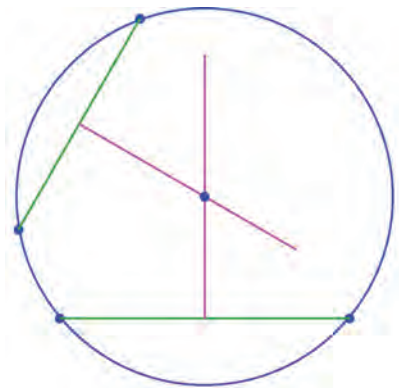

The job is done; let's now record what we learnt from it:

The perpendicular bisector of the line joining any two points on a circle passes through the centre of the circle.

To avoid the long phrase “a line joining two points of a circle”, we give such lines a name. (To think a lot and say a little is the way of mathematics). A line joining two points on a circle is called a **chord**.



0 1 2 3 4 5 6 7 8 9

Thus our general conclusion can be put like this:

The perpendicular bisector of any chord of a circle passes through its centre.

Now if we just have a part of a circle (a piece of bangle, for example) can't we find the centre and thereby complete the full circle? Just draw two chords inside the piece and draw their perpendicular bisectors:

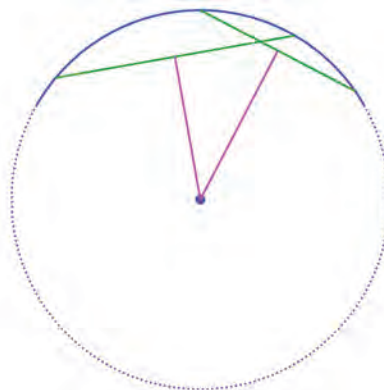
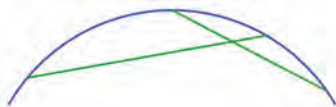

Draw a circle in GeoGebra and mark two points on it. Join these to get a chord of the circle, and draw its perpendicular bisector. Doesn't it pass through the centre? Change the positions of the points and check.

We reached the above conclusion, starting from the observation that the ends of a chord and the centre form an isosceles triangle. We have seen in Class 8 that the relations between the base and the third vertex of an isosceles triangle can be put in different ways:

- The perpendicular from the third vertex bisects the base.
- The line joining the third vertex and the midpoint of the base is perpendicular to the base.
- The third vertex is on the perpendicular bisector of the base.

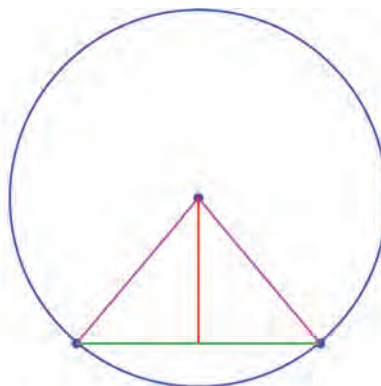

Our statement on chords of a circle is formed by taking the base as a chord and the third vertex as the centre in the third statement above. Similarly we can rewrite the first two statements on triangles as statements about circles.

The perpendicular from the centre of a circle to a chord bisects the chord.

The line joining the centre of a circle and the midpoint of a chord is perpendicular to the chord.

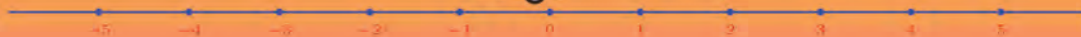



Let's look at another problem. Draw a circle and an equilateral triangle inside it, with all the vertices of the triangle on the circle.

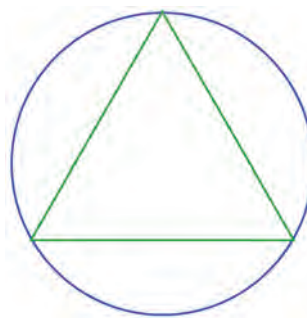

The sides of the triangle are chords of the circle, right? So we need only draw three equal chords, each pair of which intersect on the circle.

Chord and Cord

A chord of a circle is called *jya* in Sanskrit. This word actually means bowstring.

The portion of a circle consisting of a chord and part of the circle connecting its end points does look like a bow, right?



The word chord in English comes from the word *chorda* in Latin, meaning rope. Now we use the word cord in English for a string.

It's easy to draw two equal chords from a point on the circle; but the chord joining their end points may not be of the same length.

So we must draw the first chord itself with some care. Let's see what is special about a chord which is a side of an equilateral triangle.

What are the measures of the angles got by joining the vertices of such a triangle to the centre of the circle?

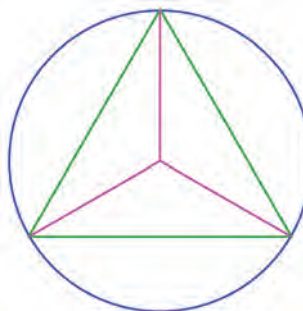

The sides of the three little triangles within the equilateral triangle are of the same length; aren't they? So, their angles must also be the same. What are the angles between the radii in this figure?

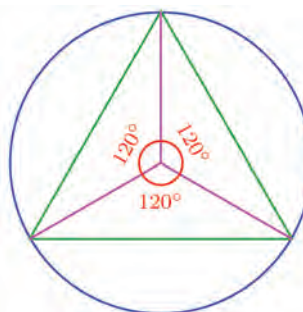

0 1 2 3 4 5 6 7 8 9



Thus if we draw three radii 120° apart, then their ends can be joined to form an equilateral triangle.

There's another way to do this, without drawing any angles. To see this, draw the radius perpendicular to one of the sides of the triangle. It bisects this side and the angle opposite to it (why?)

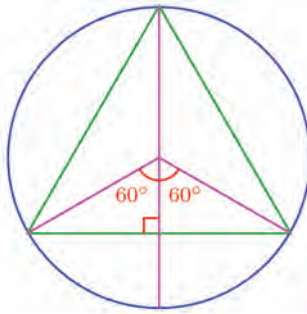

Now suppose we join the end of this radius and the end of the perpendicular side, don't we get a small equilateral triangle? (Why is it so?)

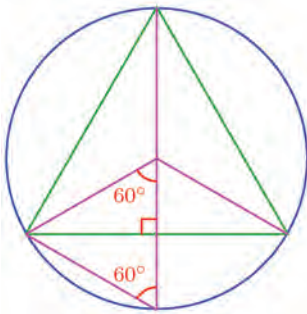

The bottom side of the large triangle is the perpendicular drawn from one vertex of this small equilateral triangle to its opposite side; so it bisects this side of the small triangle.

So, what do you see here?

Each side of an equilateral triangle drawn with its vertices on a circle bisects the radius perpendicular to it; thus it is the perpendicular bisector of the radius.

Doesn't this give an easy method to draw an equilateral triangle with vertices on a circle?

Draw the perpendicular bisector of some radius of the circle:

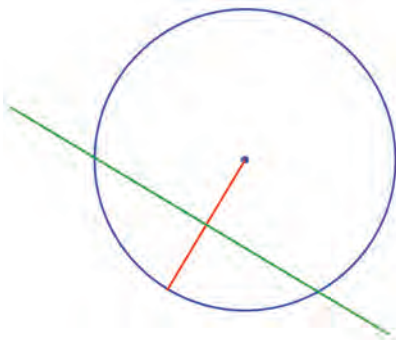



The chord which this line makes inside the circle is one side of the equilateral triangle; another point on the circle which is at the same distance from one end of the chord gives the third vertex of the triangle:

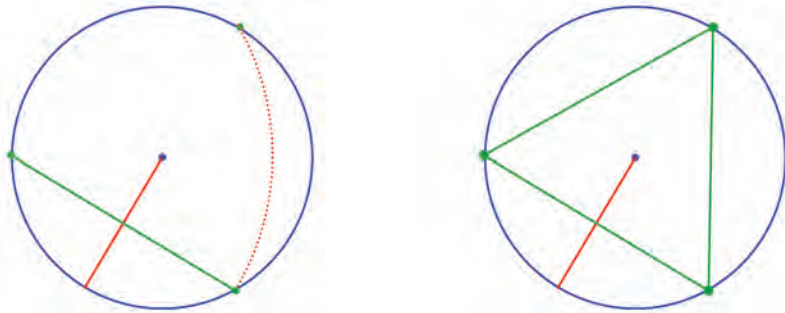

- (1) Prove that the line joining the centres of two intersecting circles is the perpendicular bisector of the line joining the points of intersection.

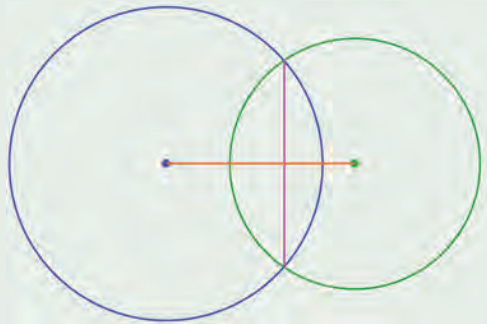

Draw two circles with the same centre. Draw chord AB of the outer circle, and mark the point C, D where it cuts the inner circle. Mark the lengths AC and DB. Are they equal? Change the positions of A and B and check.

- (2) The picture on the right shows two circles centred on the same point and a line intersecting them.

Prove that the parts of the line between the circles on either side are equal.

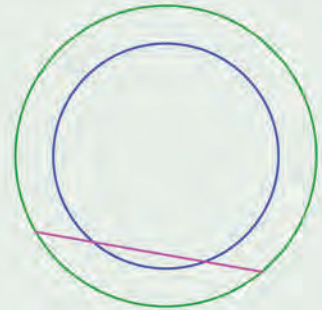

- (3) The figure shows two chords drawn on either sides of a diameter:

What is the length of the other chord?

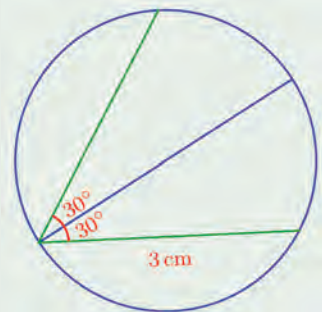

0 1 2 3 4 5 6 7 8 9

- (4) A chord and the diameter through one of its ends are drawn in a circle. A chord of the same inclination is drawn on the other side of the diameter.

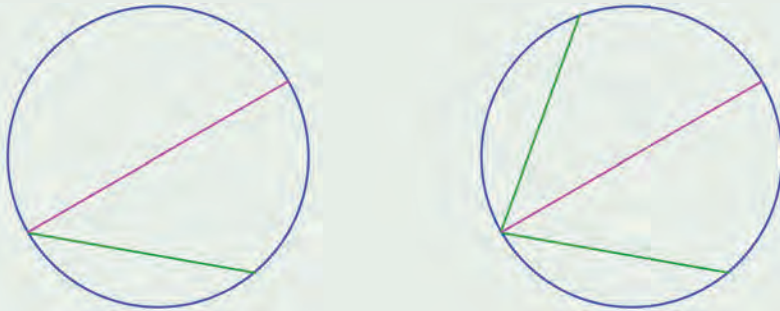

Prove that the chords are of the same length.

- (5) The figure shows two chords drawn on either sides of a diameter:
How much is the angle the other chord makes with the diameter?

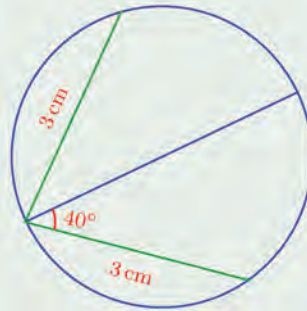

- (6) Prove that the angle made by two equal chords drawn from a point on the circle is bisected by the diameter through that point.
- (7) Draw a square and a circle through all four vertices. Draw diameters parallel to the sides of the square and draw a polygon joining the end points of these diameters and the vertices of the square:

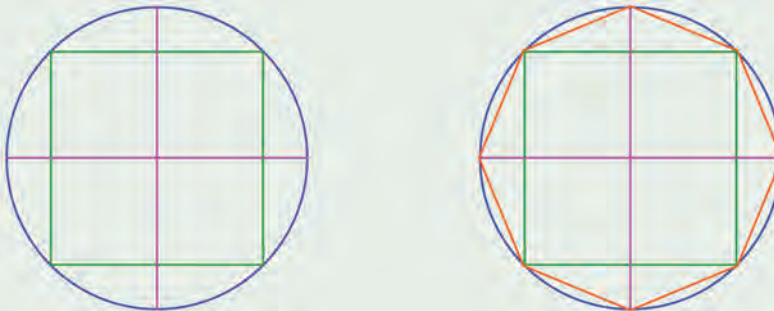

Prove that this polygon is a regular octagon.



Equal chords

Diameters of a circle are chords through the centre of the circle; and they are also the longest chords. As the chords move away from the centre, their lengths decrease:

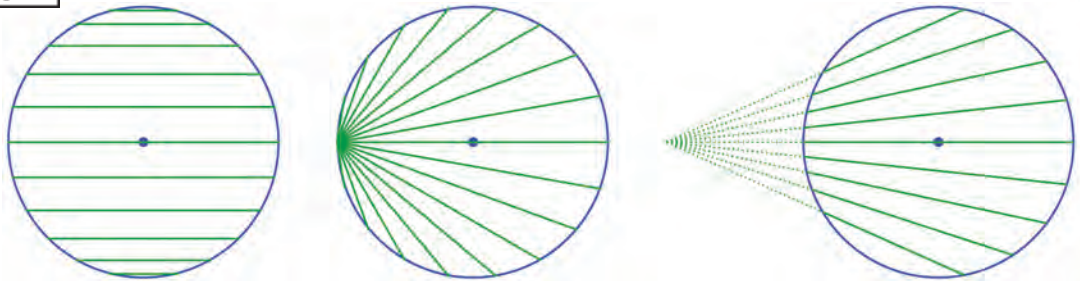

Can you see that the chords at the same distance from the centre are of the same length, whatever way they are moved, by sliding or rotating?



Draw a circle in GeoGebra and join two points on it to draw a chord. Mark its midpoint and enable **Trace On**. Also enable **Animation** for the end points of the chord. What is the path of the midpoint of the chord? Why is this so? Enable Trace on for the chord also. You can colour the chord to get a pretty picture.

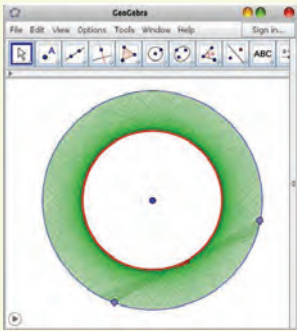

See this picture:

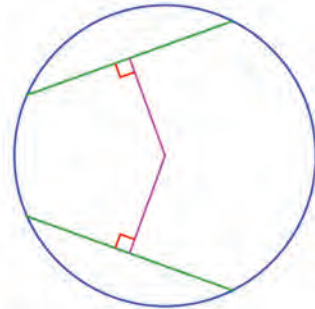

Two chords at the same perpendicular distance from the centre. To prove that they are of the same length, join one end of each to the centre:

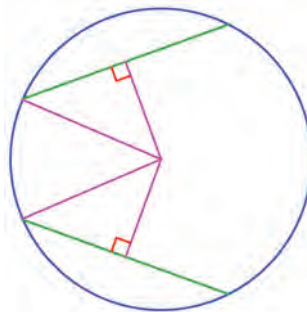

In the two right triangles obtained thus, the hypotenuses are equal, being radii of the circle. And one pair of perpendicular sides are said to be equal. So by Pythagoras Theorem, the third sides are also equal.

These third sides are half the chords, being the parts cut off by perpendiculars from the centre. Thus we see that half the chords are equal and hence the chords themselves are also equal.



0 1 2 3 4 5 6 7 8 9

Chords at the same distance from the centre are of the same length.

Conversely, starting with equal chords, can you prove that they are at equal distances from the centre? Try it!

Let's look at a problem based on this. The picture on the right shows two equal chords extended to meet at a point outside the circle.

Joining this point with the centre of the circle and drawing perpendiculars from the centre to the chords, we get two right triangles.

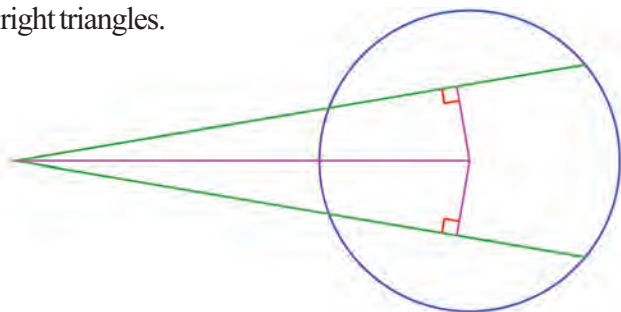

They have the same hypotenuse; and since the chords are equal, so are the perpendiculars from the centre. Thus a pair of perpendicular sides of the triangle are also equal. So their angles outside the circle are also equal. That is, the line joining the centre and the point of intersection of the chords is the bisector of the angle between the extended chords. And this line is an extension of the diameter.

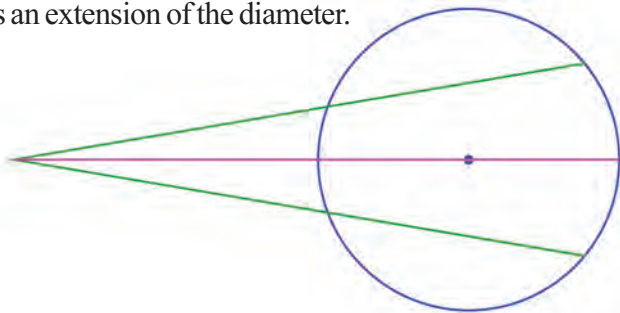

We have seen in an earlier problem that if two equal chords meet at a point on the circle, then the diameter through this point bisects the angle between the chords. Now we see that this is true, even if the chords intersect outside the circle.

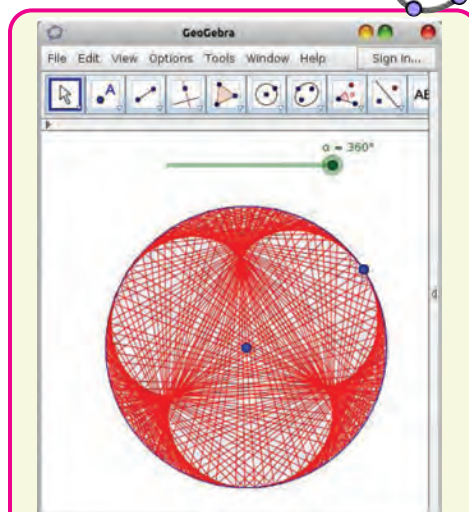

Let's see how a picture like this can be drawn in GeoGebra. Draw a circle centred at a point A and mark a point B on it. Make an angle slider α . Select **Angle with Given Size** and click on B and A in order. In the window coming up, give the size of the angle as α . We get a new point B'. Similarly get another point B'' such that $\angle B'AB'' = \alpha$. Join B', B'' and enable **Trace On**. Animate the slider and see. Instead of specifying $\angle B'AB''$ as α , try 2α , 3α , 4α , ... The picture shows what we get for $\angle B'AB'' = 3\alpha$.



- (1) Prove that chords of the same length in a circle are at the same distance from the centre.
- (2) Two chords intersect at a point on a circle and the diameter through this point bisects the angle between the chords. Prove that the chords have the same length.
- (3) In the picture on the right, the angles between the radii and the chords are equal. Prove that the chords are of the same length.

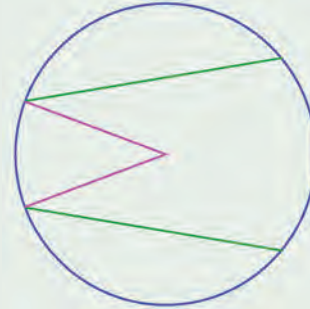

Length of Chords

We have seen that length of a chord is determined by the distance from the centre. Let's look at the actual computation now.

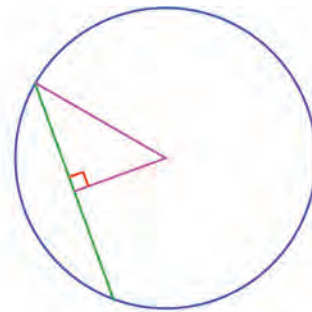
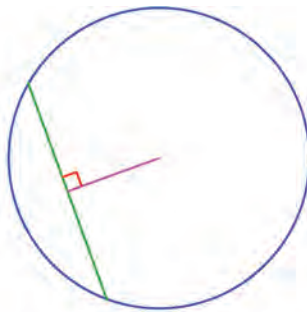

The picture on the left shows a chord of a circle and the perpendicular from the centre. In the picture on the right, one end of the chord is joined to the centre, to form a right triangle.

The hypotenuse of this right triangle is the radius of the circle, one of the shorter sides is the perpendicular from the centre and the third side is half the chord. So, we can calculate the length of the square of half the chord using Pythagoras Theorem:

In a circle, the square of half a chord is the difference of the squares of the radius and the perpendicular from the centre to the chord.



0 1 2 3 4 5 6 7 8 9

For example, in a circle of radius 4 centimetres, the square of half a chord at a (perpendicular) distance 3 centimetres from the centre is $4^2 - 3^2 = 7$; so the length of the chord is $2\sqrt{7}$ centimetres.

Now consider this problem: The distance between the ends of a piece of a bangle is 4 centimetres and its height is 1 centimetre:



We have to calculate the radius of the full bangle. We can imagine the bangle like this:

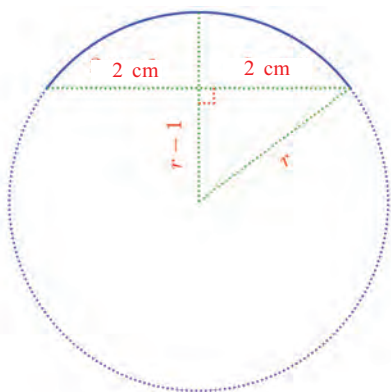

Lotus problem

Haven't you heard about the mathematical text *Leelavati* by Bhaskaracharya? Here is the translation of one of its verses:

"In a lake full of frolicking birds,
Stands a lotus bud
Half a palm high
Moving lazily in the wind
It sank down two palms away
Tell me quickly, mathematician
How deep the water is!"

Can't you find the answer to this as we found the radius of the bangle?

Taking the radius of the bangle to be r , we have from the right triangle in the picture,

$$r^2 - (r - 1)^2 = 4$$

Simplifying this, we get $2r - 1 = 4$ and so $r = 2\frac{1}{2}$. Thus the radius of the bangle is 2.5 centimetres.



- (1) In a circle, a chord 1 centimetre away from the centre is 6 centimetres long. What is the length of a chord 2 centimetres away from the centre?
- (2) In a circle of radius 5 centimetres, two parallel chords of lengths 6 and 8 centimetres are drawn on either side of a diameter. What is the distance between them? If parallel chords of these lengths are drawn on the same side of a diameter, what would be the distance between them?



- (3) The bottom side of the quadrilateral in the picture is a diameter of the circle and the top side is a chord parallel to it. Calculate the area of the quadrilateral.

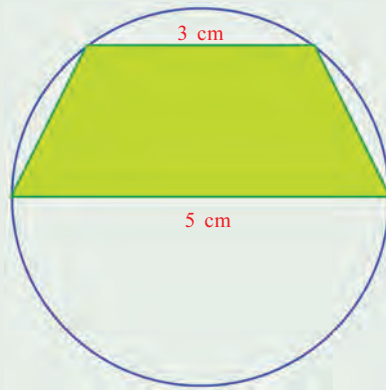

- (4) In a circle, two parallel chords of lengths 4 and 6 centimetres are 5 centimetres apart. What is the radius of the circle?

Points and circles

We have been talking about lines joining two points on a circle. Now consider a question in reverse: How do we draw a circle through the ends of a line?

We can join any two points by a line. So the question can be put like this: Can we draw a circle through any two points?

Mark two points in your notebook. Can you draw a circle passing through them?

A quick solution is to draw a circle with the line joining the points as diameter.

Can you draw another circle?

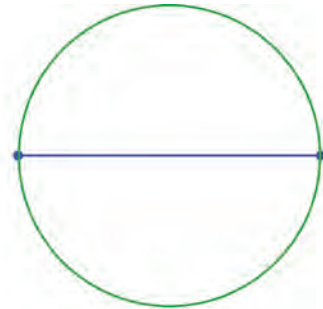

If such a circle is drawn, the line joining the points would be a chord. So, the centre of the circle would be on its perpendicular bisector.

We can choose any point on this bisector as the centre, to draw a circle through these points, right?



0 1 2 3 4 5 6 7 8 9



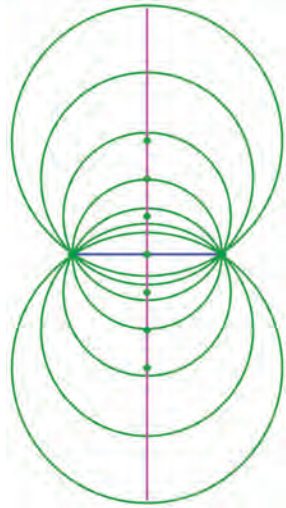

Draw a line and its perpendicular bisector in GeoGebra. Mark a point on the bisector and draw a circle with centre at this point and passing through an end point of the line. Enable **Animation** for the centre. **Trace On** may be enabled for the circle.

Now a new question, can we draw a circle through any three points?

If the points are on a line, we cannot.

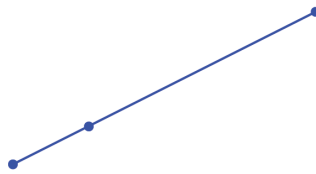

What if they are not on a line?

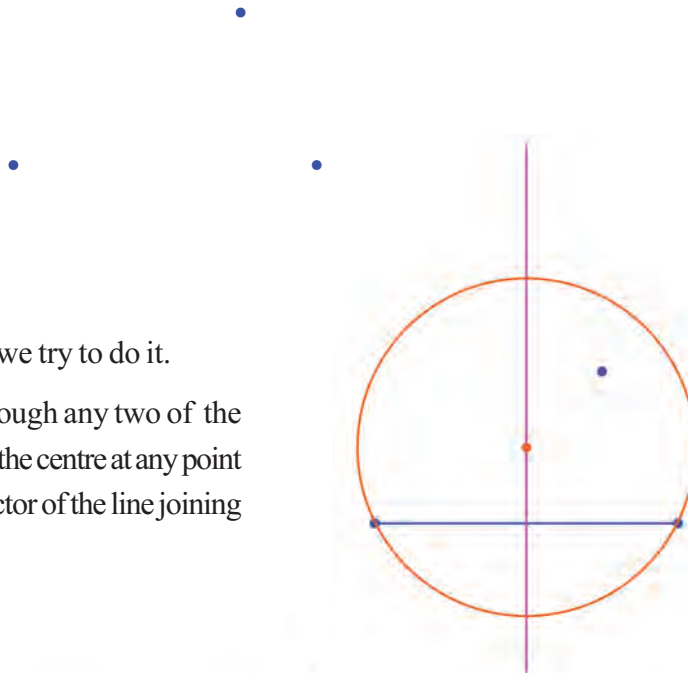

Let's think a bit, before we try to do it.

We can draw a circle through any two of the points given, by choosing the centre at any point on the perpendicular bisector of the line joining them.



Taking another pair of points and choosing a point on the perpendicular bisector of the line joining them as centre, we can draw a circle passing through them.

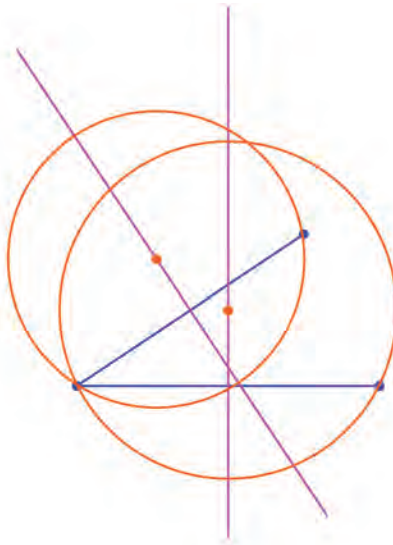

Thus we can draw two circles passing through two pairs of points. But what we need is a single circle passing through all three points.

For a circle through the first pair of points, the centre must be on the first bisector and for a circle through the second pair, the centre must be on the second bisector.

Line and circle

Through one point, we can draw as many lines as we want; and circles too.

Through two points, we can draw only one line; but as many circles as we want.

It may not be possible to draw a line through three points. If we can draw a line through three points, we cannot draw a circle through them; and if the three points are such that we cannot draw a line through them, then we can draw a circle through them.

Is it possible to draw a line through four points? What about circle?

What if we take as the centre, a point on both the bisectors? that is, their point of intersection?

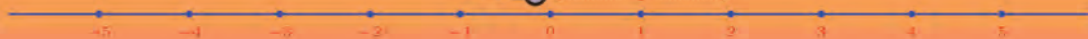
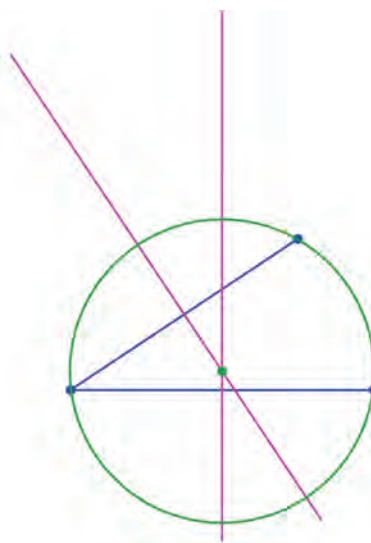

0 1 2 3 4 5 6 7 8 9

If we join the remaining pair of points also, we get a triangle; and the circle passes through all its vertices.

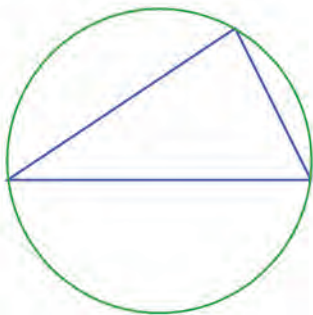

Such a circle, passing through all three vertices of a triangle is called the **circumcircle** of the triangle.

We can draw the circumcircle of any triangle by choosing as centre, the point of intersection of the perpendicular bisectors of two sides, as we have done just now.

We can note another thing here. In our example, we drew the perpendicular bisectors of the bottom and left sides of the triangle to get the centre of the circumcircle. Since the right side is also a chord of the circumcircle, its perpendicular bisector also passes through the centre.

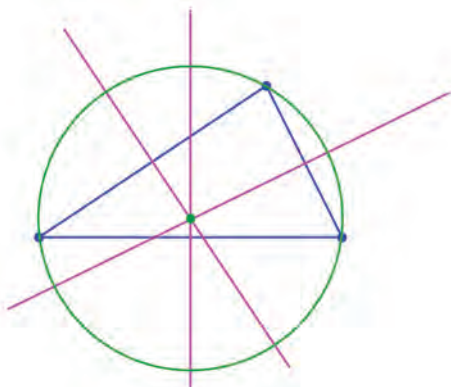

In any triangle, the perpendicular bisectors of all three sides intersect at a single point.

In GeoGebra, we can draw a **Circle Through 3 Points** by using a tool of this name. Make an angle Slider α and draw a triangle with one angle α . Draw its circumcircle and mark its centre using **Midpoint or Centre**. Move the slider to change α and see how the position of circumcentre changes. When is it inside the triangle? When is it outside? Will it be on a side of the triangle at any time?





- (1) Draw three triangles with lengths of two sides 4 and 5 centimetres and the angle between them 60° , 90° , 120° . Draw the circumcircle of each. (Note how the position of the circumcentre changes).
- (2) The equal sides of an isosceles triangle are 8 centimetres long and the radius of its circumcircle is 5 centimetres. Calculate the length of its third side.
- (3) Find the relation between the length of a side and the circumradius of an equilateral triangle.

0 1 2 3 4 5 6 7 8 9

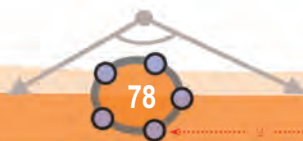

Parallel Lines

6

Parallel division

We have learnt many things about parallel lines and have drawn many figures using them. There is much more.

Let's start by drawing a line, another line parallel to it 2 centimetres below and one more line parallel to these, 4 centimetres above:



Now if we measure vertically from any point on the bottom line, the distances are again 2 centimetres and 4 centimetres:

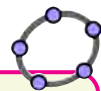
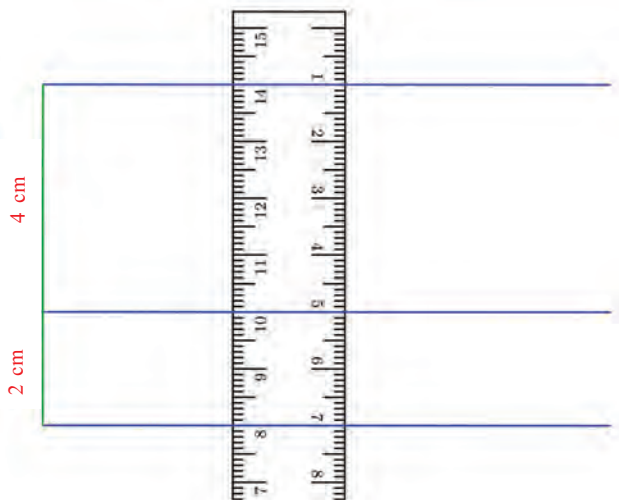

Draw a line and then draw a line at distance 2 away from it on one side and another line at distance 4 from it on the other side. Mark points A, B on these lines and mark the point C where AB intersects the middle line.

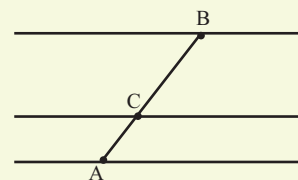

Mark the distances AC and BC. What relation do you see between these? Change the positions of A, B and check. Try changing the distances between the lines also.



What if we measure at a slant?

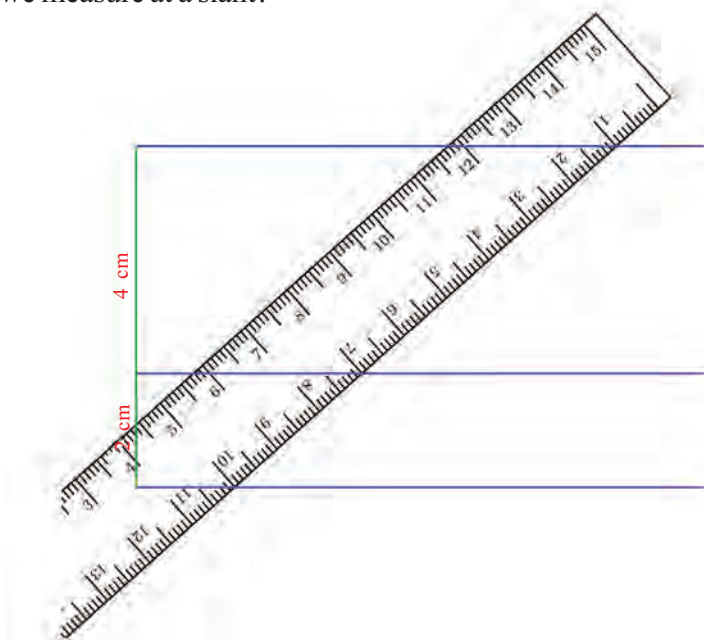

Look at the right edge of the ruler. What are the distances along it?

Measure along different slants. What do you see?

Along whatever line we measure, the distance from the middle line to the top line is double the distance from the bottom line to the middle line, isn't it?

In other words, the ratio of the distances along any line is the same as the ratio of the vertical distances, right?

Let's see if this is true for any three parallel lines. First let's make our guess clear. See this picture:

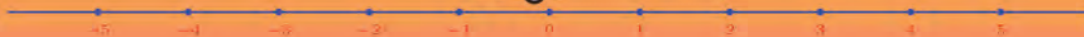
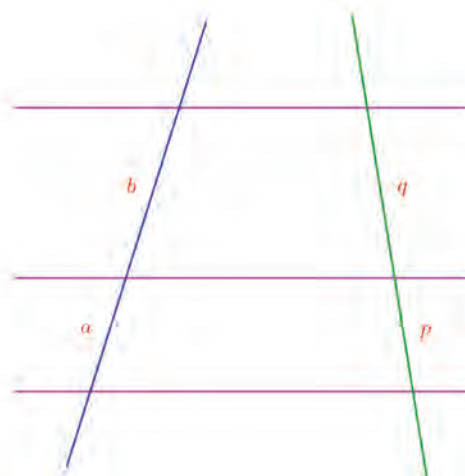

0 1 2 3 4 5 6 7 8 9



There are three horizontal lines parallel to one another and two slanted lines cutting them across. Taking the lengths of the parts cut off on the left line as a, b and those on the right line as p, q , we have to verify whether the ratios $a : b$ and $p : q$ are the same.

For this, we first convert the ratio $a : b$ of lengths into a ratio of areas.

See the picture above. Isn't $a : b$, the ratio of the areas of the lower and upper triangles? (The section, **Triangle division** of the lesson, **Area**)

Taking these areas as A and B , we have

$$\frac{a}{b} = \frac{A}{B}$$

In the same way, the ratio of the lengths p, q can be rewritten as a ratio of areas.

If we take P and Q as the areas of the green triangles, then

$$\frac{p}{q} = \frac{P}{Q}$$

Now let's look at all the triangles together:

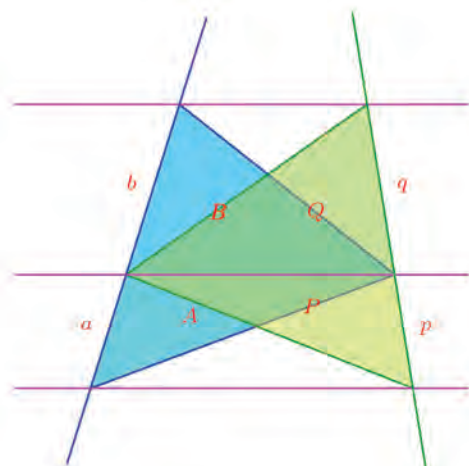
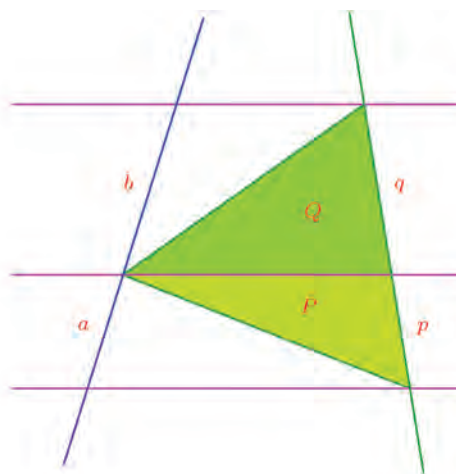
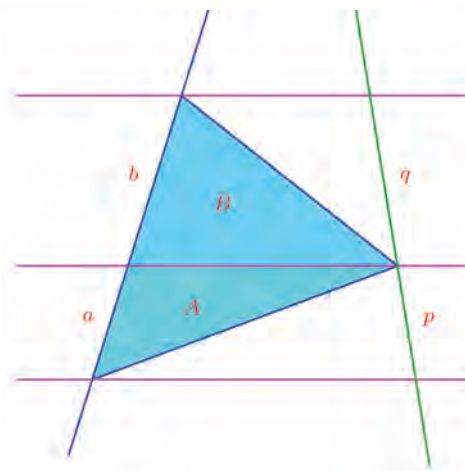

0 1 2 3 4 5 6 7 8 9



Now the lower blue and green triangles share a common side; and their third vertices are on a line parallel to this side. So, they have the same area:

$$A = P$$

Things are the same for the upper blue and green triangles also, aren't they? So,

$$B = Q$$

We have seen that $\frac{a}{b} = \frac{A}{B}$ and $\frac{p}{q} = \frac{P}{Q}$. Now we find that $A = P$ and $B = Q$ also. Putting all these together, we get

$$\frac{a}{b} = \frac{p}{q}$$

Thus any three parallel lines cut any two lines into pieces whose lengths are in the same ratio. We can extend the above reasoning to more than three parallel lines also.

Three or more parallel lines cut any two lines into the same ratio.

For example, in all three pictures below, the lengths a, b and c are in the same ratio as the lengths p, q and r :

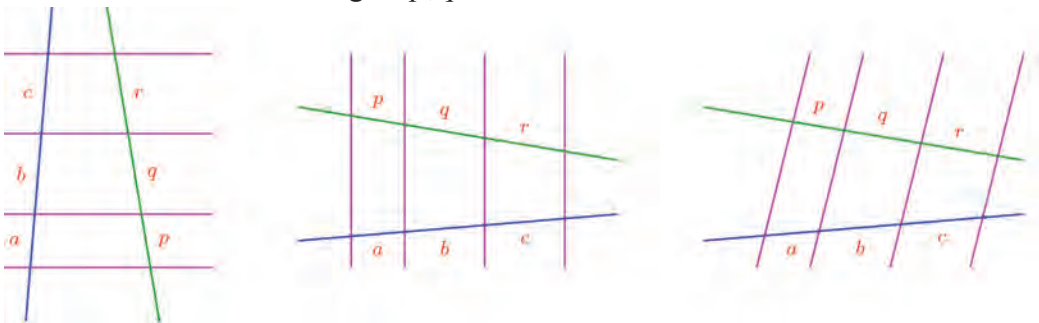

So what if some set of parallel lines cut a line into equal pieces? According to our general principle, they will cut any other line also into equal pieces.

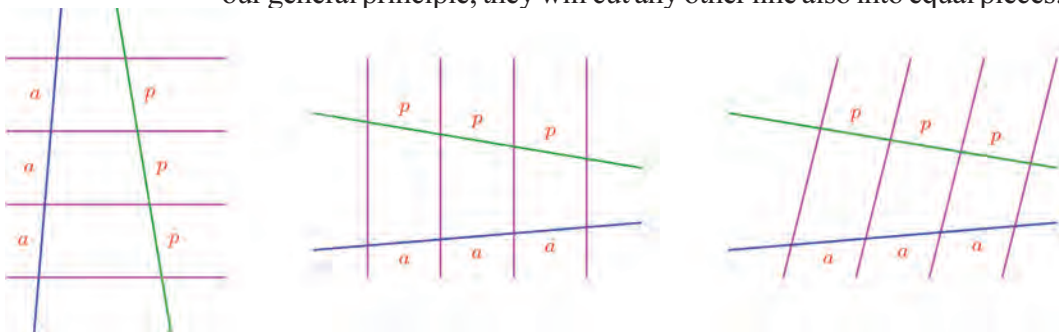

If three or more parallel lines cut a line into equal parts, they will cut any line into equal parts.

Now let's see how these can be applied.

A 7 centimetre long line can be cut into two equal pieces by drawing the perpendicular bisector; or we can just mark a point 3.5 centimetres away from one end. How do we divide it into three equal parts?

It is easy to do in a 6 centimetre long line.

Four parallel lines cutting a 6 centimetre line into three equal parts, will cut any other line into three equal parts, right?

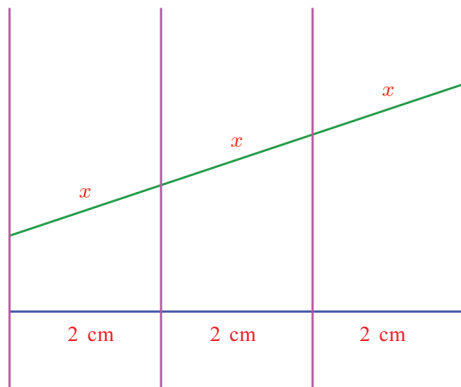

Suppose we make the length of the second line 7 centimetres?

So our way ahead is clear, isn't it?

Draw a line 6 centimetres long and draw perpendiculars to it, 2 centimetres apart. With some point on the first perpendicular as the centre, draw an arc of radius 7 centimetres to cut the last perpendicular.

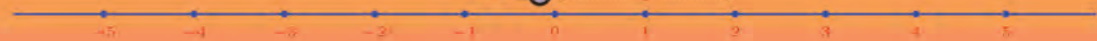
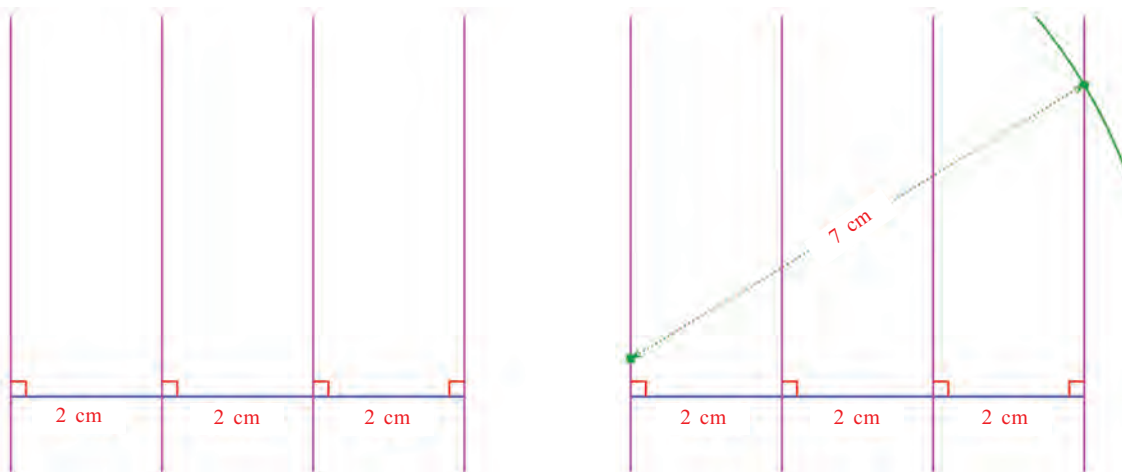

0 1 2 3 4 5 6 7 8 9





Joining the first and last points, we have a line 7 centimetres long, cut into three equal parts.

Circle division

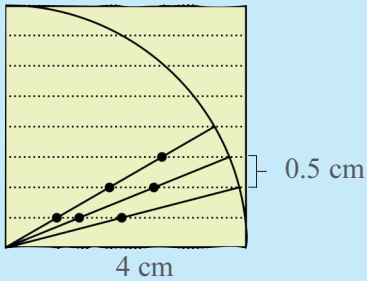

See how a 4 centimetres long line is divided into two, three and four equal parts in this picture. Using this, can't we divide it up to eight equal parts? Like this can you divide a 6 centimetres line into 7 equal parts, using ruled paper?

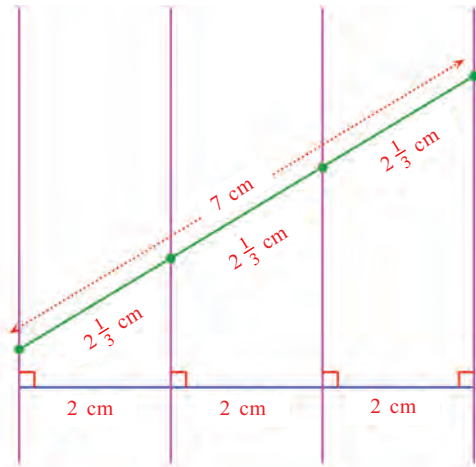

There is a slightly different way to do this:

Draw a line 7 centimetres long and from one end, draw another line 6 centimetres long at a slant.

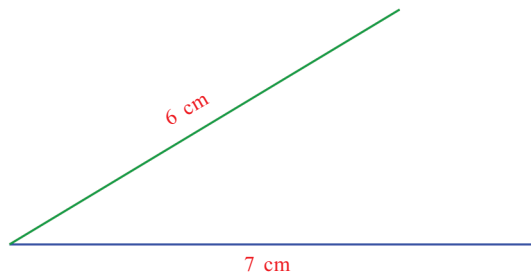

Join the other ends of these lines. Divide the upper line into three equal parts and draw parallel lines through these points.

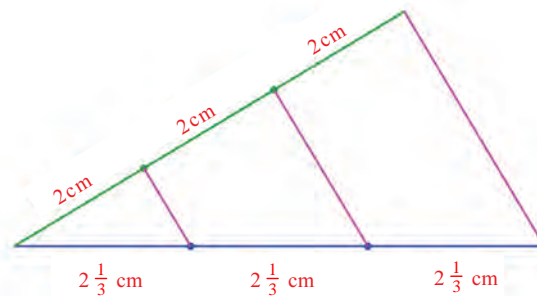

0 1 2 3 4 5 6 7 8 9

If you can't see why this works, imagine the parallel lines extended a bit and also a fourth parallel:

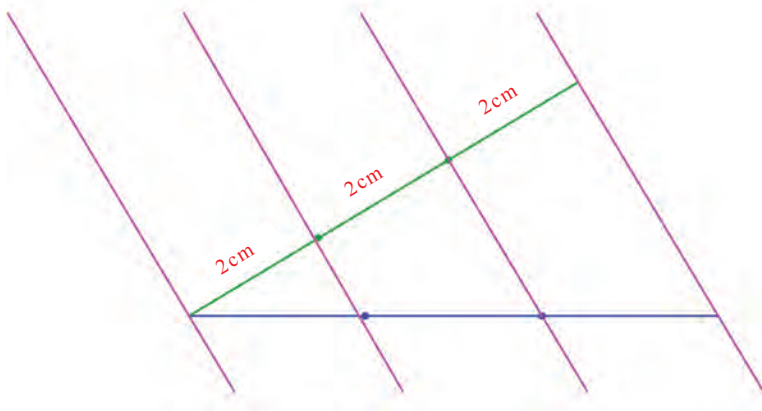

Shadow math

The height up to the lowest branch of a tree is 1 metre and the length of the shadow of this part is 2 metres. The total length of the shadow is 8 metres. What is the height of the tree?



Let's look at another problem.

What is the perimeter of the rectangle on the right?

How do we draw a rectangle with sides in the same ratio and perimeter 17 centimetres?

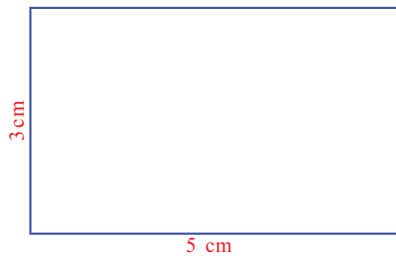

Perimeter of 17 centimetres means the sum of the lengths of the sides is 8.5 centimetres. So we need only draw a line 8.5 centimetres long, divide it in the ratio 5 : 3, and use the parts as the sides of the rectangle.

So, let's first draw a line 8.5 centimetres long. To divide it in the ratio 5 : 3, we proceed as in the second method of doing the first problem. Draw a line 8 centimetres long from one end and divide it into 5 centimetres and 3 centimetres parts:

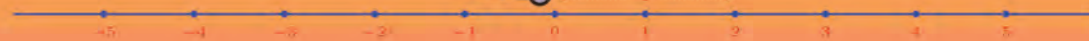
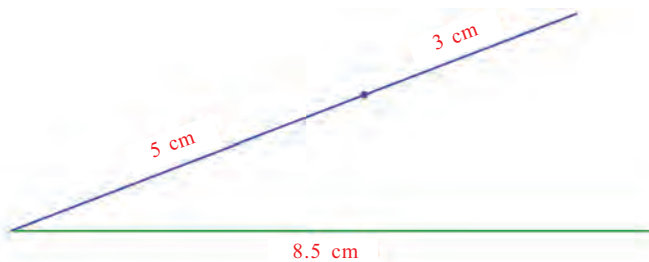

0 1 2 3 4 5 6 7 8 9



Draw lines AB and AC in GeoGebra. Make a slider c with **Min** = 0 and **Max** = 1. With A as centre, draw a circle of radius c times the length of AB. (For this, give the radius of the circle as $c * AB$ or ca . Here a is the length of AB). Mark the point D where this circle cuts AB. Similarly, mark the point E on AC at a distance c times the length of AC, from A. Draw the lines AD, AE and mark their lengths. What is the relation between them? Move the slider and see. Draw the lines BC and DE. What is the relation between them?

Now join the other ends of the lines and draw a line parallel to it through the point of division of the shorter lines to cut the longer line in the ratio 5 : 3.

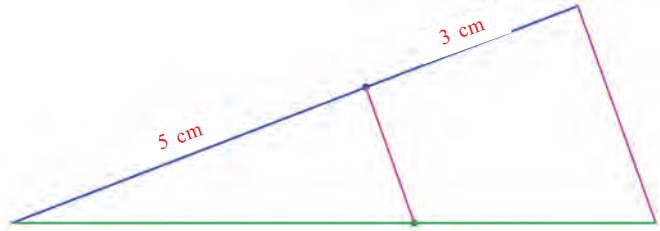

And the rectangle we require is the one with these parts as sides:

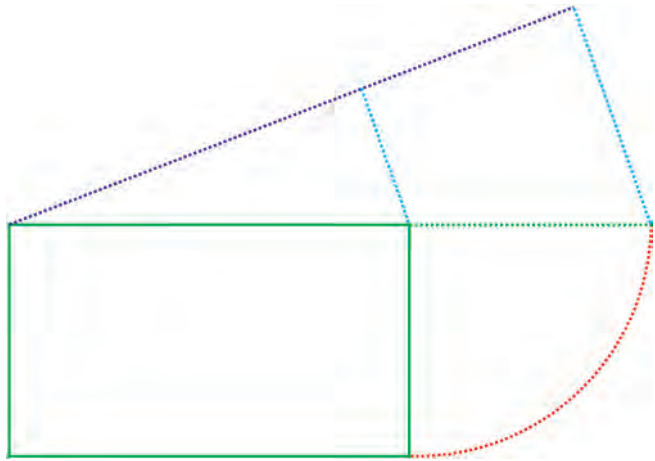

A slightly different problem:
A rectangle is shown here.



Its length and breadth are not given. We must draw a rectangle with the same ratio of sides, but with perimeter 3 centimetres more.

For this, we first put the length and width of the given rectangle along one line:

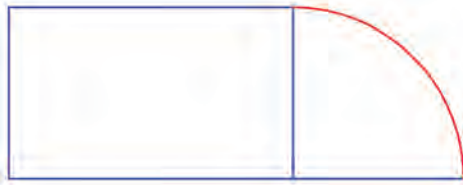

Now we draw below it another line of the same length at a slant and extend it by 1.5 centimetres. (Why?)



0 1 2 3 4 5 6 7 8 9

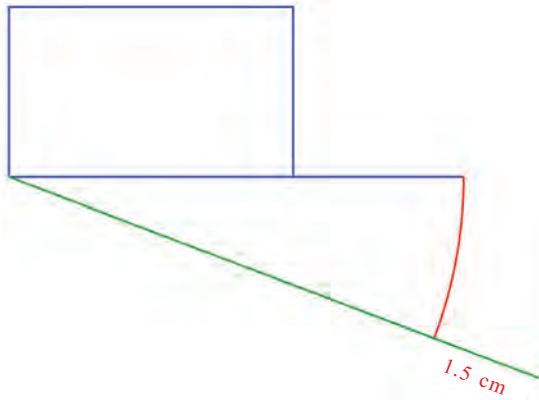

Now join the other ends of the lines and draw a parallel to it to cut the lower line.

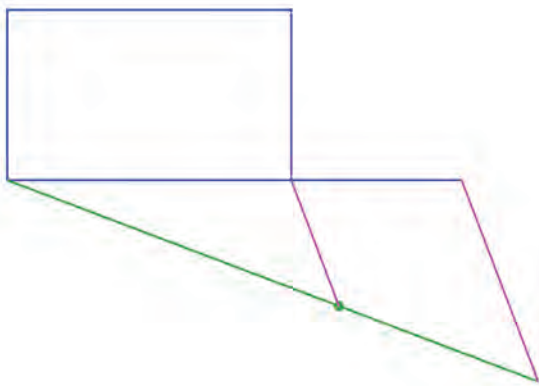

Now we can draw the required rectangle with parts of the lower line as sides.

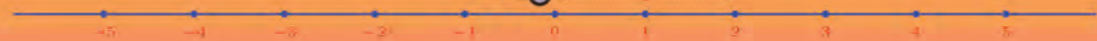
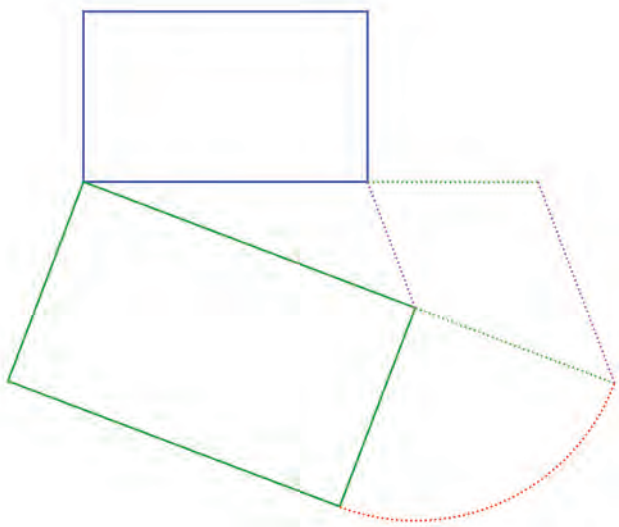

0 1 2 3 4 5 6 7 8 9





- (1) Draw an 8 centimetres long line and divide it in the ratio 2 : 3.
- (2) Draw a rectangle of perimeter 15 centimetres and sides in the ratio 3 : 4.
- (3) Draw triangles specified below, each of perimeter 10 centimetres.
 - i) Equilateral triangle
 - ii) Sides in the ratio 3 : 4 : 5
 - iii) Sides in the ratio 2 : 3 : 4
- (4) In the picture below, the diagonals of the trapezium $ABCD$ intersect at P .

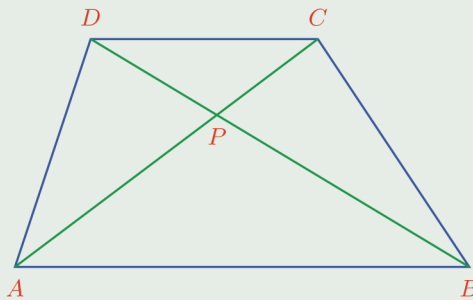

Prove that $PA \times PD = PB \times PC$

Triangle division

Draw a triangle and within it, draw a line parallel to one side.

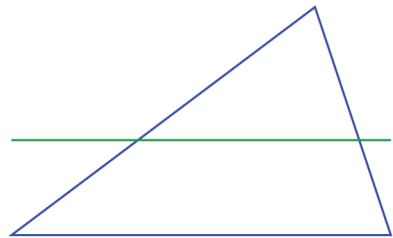

Draw triangle ABC in GeoGebra and mark a point D on AB . Draw a line through D , parallel to BC and mark the point E where it cuts AC . Check if D and E divide AB and AC in the same ratio. You can mark the lengths and see this.

Is there any relation between the parts into which the line divides the other sides?

What if we draw another line parallel to the bottom side, through the top vertex?

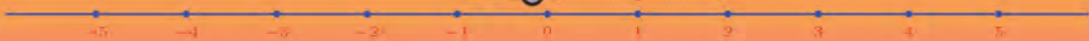
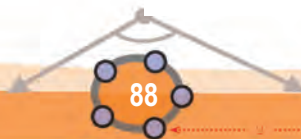
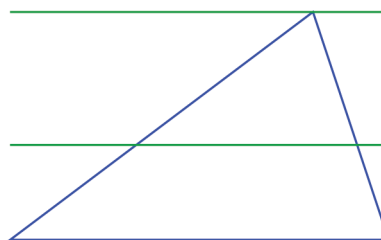

0 1 2 3 4 5 6 7 8 9

Now three parallel lines cut the left and right sides of the triangle. The ratio of the parts must be the same. And these parts are those cut by the first line.

So, what do we see here?

In any triangle, a line drawn parallel to a side cuts the other two sides in the same ratio.

On the other hand, what can we say about the line joining two points which divide the sides of a triangle in the same ratio?

For example in the figure below, the points dividing the left and right sides of a triangle in the ratio 1 : 2 are marked:

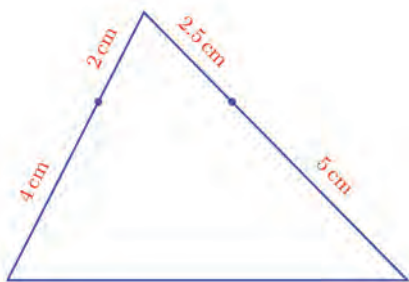

The line through the left point, parallel to the bottom side passes through the right point also, by the principle noted above. In other words the line joining these points is parallel to the bottom side:

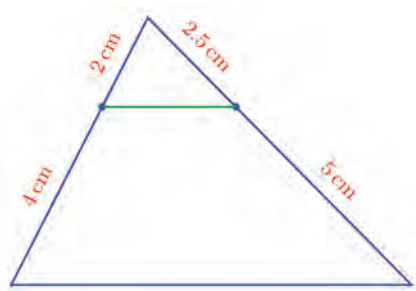

This is true, whatever be the ratio, isn't it? So, what do we get?

A line which divides two sides of a triangle in the same ratio is parallel to the third side

External line

We can show that a line outside a triangle parallel to one side also intersects the other two sides in the same ratio.

See this picture:

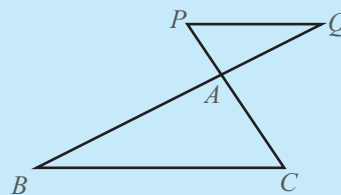

PQ is parallel to BC.

Draw another line parallel to BC through A.

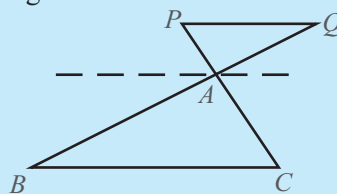

So,

$$\frac{AC}{AP} = \frac{AB}{AQ}$$

Also from the picture, we see that

$$\frac{PC}{AP} = \frac{AP + AC}{AP} = 1 + \frac{AC}{AP}$$

$$\frac{QB}{AQ} = \frac{AQ + AB}{AQ} = 1 + \frac{AB}{AQ}$$

From these equations we see that

$$\frac{AP}{PC} = \frac{AQ}{QB}$$



Now see this picture:



Draw a triangle and mark the midpoints of its sides. Draw the triangle joining these mid points. Mark the length of the sides of outer and inner triangles. What is the relation between them? Change the corners of the first triangle and check.

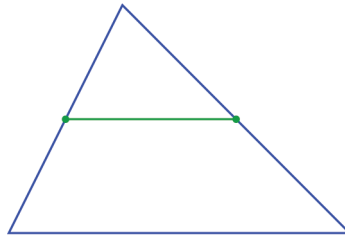

The green line is drawn joining the mid points of the left and right sides of the blue triangle. By the result stated above, this line is parallel to the bottom side of the triangle.

What if we connect the mid points of all three sides?

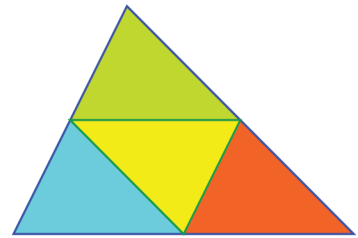
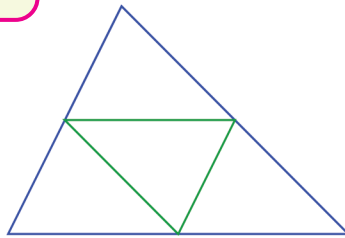

What can we say about these four smaller triangles? The sides of the yellow triangle in the middle are parallel to the sides of the large triangle.

Don't all four triangles look equal? Let's check whether it is true. Let's take the yellow and blue triangles. The left side of the yellow triangle is the same as the right side of the blue triangle. The lower angle on this side in the yellow triangle is equal to the upper angle on this side in the blue triangle. (Why?)

In the same way, the other angles on this side in the two triangles are also equal. So these two triangles are equal. Similarly, the red triangle and the green triangle can also be seen to be equal to the yellow triangle. Thus all the four triangles are equal. We note one thing from this: since the sides of these triangles are of the same length, each is half a side of the large triangle.

The length of the line joining the midpoints of two sides of a triangle is half the length of the third side.

Now suppose we start with a small triangle and draw through each vertex, the line parallel to the opposite side.



0 1 2 3 4 5 6 7 8 9

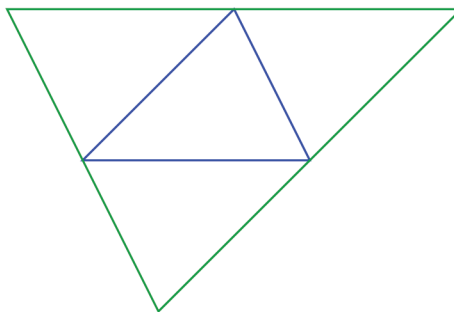
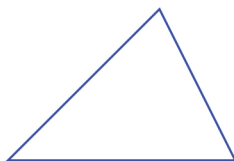

We get a large triangle, made up of three more copies of the small triangle.

Here, the line through a vertex of the small triangle, perpendicular to the opposite side, is the perpendicular bisector of the large triangle.

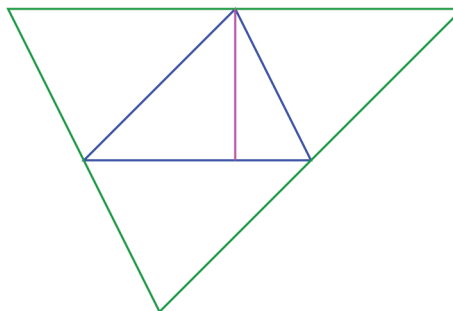

So, what if we draw all three lines from each vertex of the small triangle, perpendicular to the opposite side? We get the perpendicular bisectors of all three sides of the large triangle.

We have seen in the lesson **Circles**, that all the perpendicular bisectors of the sides of any triangle passes through a single point.

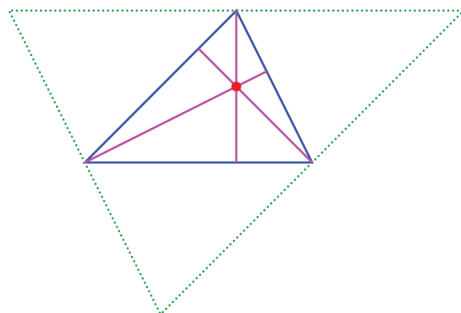

Draw a triangle and from each vertex, draw the lines perpendicular to the opposite side. Do they all pass through a single point? Shift the vertices of the triangle and check.

In any triangle, all the perpendiculars from the vertices to the opposite sides passes through a single point.

Using the same principle, we can also show that the lines joining the vertices of a triangle to the midpoint of the opposite sides passes through a single point. Such a line is called a *median* of the triangle.





Draw a triangle and mark the midpoint of the sides. Draw the medians of all sides and mark their point of intersection. Mark the distances from this point to each vertex of the triangle, and each midpoint of the side. What relations do you see between them?

In the picture below, the medians from the two bottom vertices intersect at G .

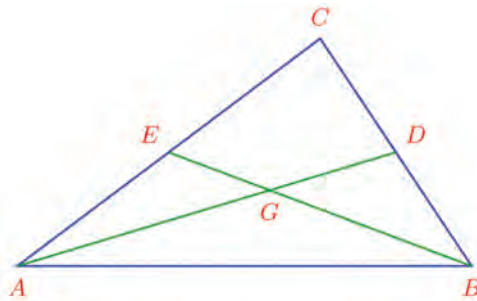

The line joining the midpoints of the left and right side is parallel to the bottom side and of half the length of this side. That is

$$ED = \frac{1}{2} AB$$

Now there is also a small triangle GAB on the bottom side. Let's join the midpoints of the left and right sides of this triangle also.

$$PQ = \frac{1}{2} AB$$

So,

$$PQ = ED$$

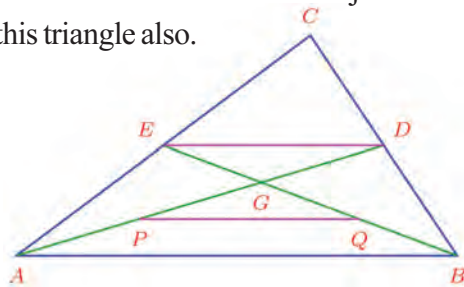

Since the sides PQ and ED of the quadrilateral $PQDE$ are equal and parallel, it is a parallelogram. So, its diagonals bisect each other. That is,

$$PG = GD$$

P is the mid point of AG , so that

$$AP = PG = GD$$

Similarly,

$$BQ = QG = GE$$

Thus the point of intersection of the two medians divide each other in the ratio 2 : 1.

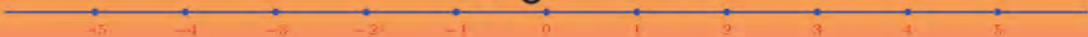

Now suppose we draw the medians through B and C , instead of those through A and B .

Their point of intersection would divide BE in the ratio $2 : 1$. Thus, the point of intersection would be G itself.

In any triangle, all the medians intersect at a single point; and that point divides each median in the ratio $2 : 1$, measured from the vertex.

The point of intersection of the medians is called the *centroid* of the triangle.



- (1) In the picture, the perpendicular is drawn from the midpoint of the hypotenuse of a right triangle to the base.

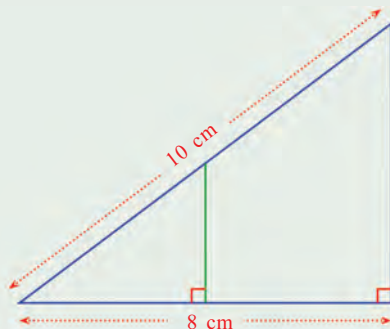

Calculate the length of the third side of the large right triangle and the lengths of all three sides of the small right triangle.

- (2) Draw a right triangle and the perpendicular from the midpoint of the hypotenuse to the base.

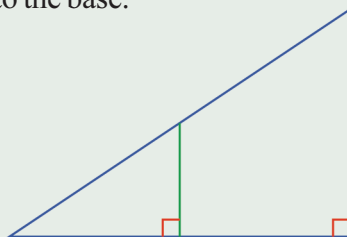

- i) Prove that this perpendicular is half the perpendicular side of the large triangle.
- ii) Prove that perpendicular bisects the bottom side of the larger triangle.

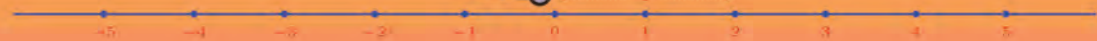

0 1 2 3 4 5 6 7 8 9



- iii) Prove that in the large triangle, the distances from the midpoint of the hypotenuse to all the vertices are equal.
- iv) Prove that the circumcentre of a right triangle is the midpoint of its hypotenuse.

- (3) In the parallelogram $ABCD$, the line drawn through a point P on AB , parallel to BC , meets AC at Q . The line through Q , parallel to AB meets AD at R .

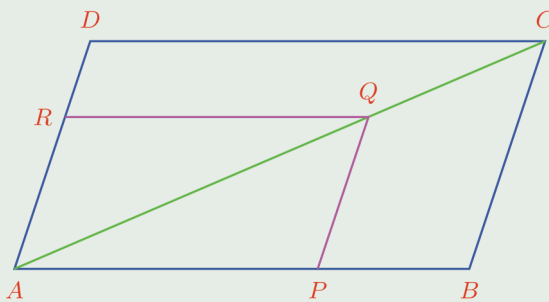

Prove that $\frac{AP}{PB} = \frac{AR}{RD}$

- (4) In the picture below, two vertices of a parallelogram are joined to the midpoints of two sides.

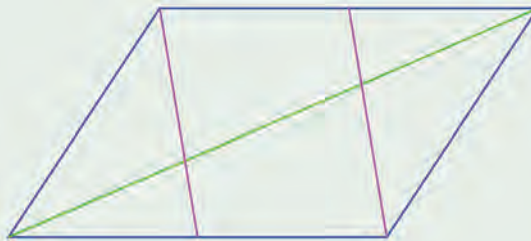

Prove that these lines divide the diagonal in the picture into three equal parts.

- (5) Prove that the quadrilateral formed by joining the mid points of the sides of a quadrilateral is a parallelogram. What if the original quadrilateral is a rectangle? What if it is a rhombus?



0 1 2 3 4 5 6 7 8 9



Similar Triangles

7

Angles and sides

We know that if all sides of one triangle are equal to the sides of another triangle, then the angles of the triangles are also equal; on the other hand we also know that just because all angles of a triangle are equal to the angles of another triangle, their sides may not be equal (the lesson, **Equal Triangles** in Class 8).

This raises the question: is there any relation between the sides of triangles with the same angles?

To check this, cut out two cardboard triangles with the same angles, but of different sizes as below:



To compare the lengths of sides, place the smaller triangle inside the larger with the left corners together. Since the angles are equal, the sides will also be aligned:



Now the right sides of both triangles are at the same inclination to the bottom line and so they are parallel. Hence the right side of the small triangle divides the left and bottom sides of the large triangle in the same ratio (The lesson, **Parallel Lines**).



To make this more precise, let's denote the lengths of the sides of the triangle by letters:

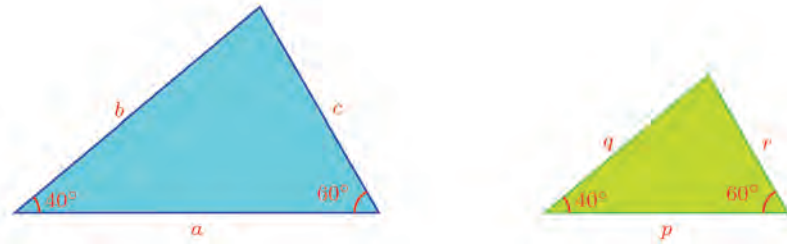

And when we place one over the other as before, we can mark the distances like this:

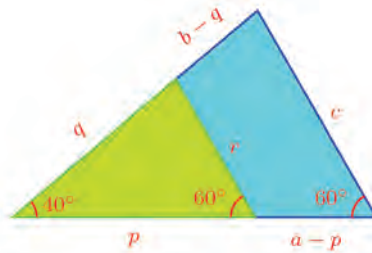

Then the equality of ratios mentioned earlier can be written like this:

$$\frac{a-p}{p} = \frac{b-q}{q}$$

This can be simplified as

$$\frac{a}{p} - 1 = \frac{b}{q} - 1$$

from which we get

$$\frac{a}{p} = \frac{b}{q}$$

What if we place the triangles with the right corners together, instead of the left?

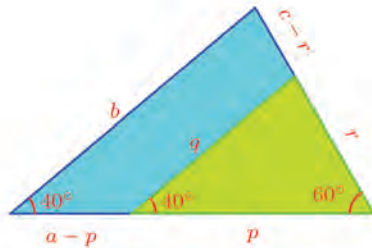

Then as before, we get

$$\frac{a-p}{p} = \frac{c-r}{r}$$

and from this,



0 1 2 3 4 5 6 7 8 9

$$\frac{a}{p} = \frac{c}{r}$$

Let's write together the two equations we got from the two different cases:

$$\frac{a}{p} = \frac{b}{q} = \frac{c}{r}$$

What does this mean?

The angles of both triangles are 40° , 60° , 80° . In these, a and p are lengths of the sides opposite the 80° angle; b and q are the lengths of the sides opposite the 60° angle, c and r are the lengths of the sides opposite the 40° angle.

$\frac{a}{p}$ is the number which shows what multiple of the length p is the length a

$\frac{b}{q}$ is the number which shows what multiple of the length q is the length b

$\frac{c}{r}$ is the number which shows what multiple of the length r is the length c

So the equality $\frac{a}{p} = \frac{b}{q} = \frac{c}{r}$ shows these multiples are the same.

That is, if we pair the lengths of sides opposite equal angles as (a, p) , (b, q) , (c, r) , then the longer lengths a, b, c are the same multiples of the shorter sides p, q, r .

In other words, the numbers a, b, c are got by multiplying the numbers p, q, r by the same number k :

$$a = kp, b = kq, c = kr$$

This reasoning holds good, whatever be the angles of the triangles, instead of just 80° , 60° , 40° as we have chosen here. Thus we have the following general principle:

In two triangles with the same angles, if we pair the sides opposite equal angles, then the longer sides are the same multiples of the shorter (or vice versa)

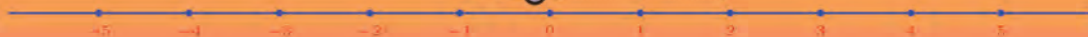



We can shorten this as below:

The sides of triangles with the same angles, taken in the order of size, are in the same ratio



Draw $\triangle ABC$ in GeoGebra and mark all its angles. Make a Slider d with $\text{Min} = 0$. Use **Segment with Given Length** to draw DE of length d times AB . For this, the length of DE can be given as $d \cdot AB$. Next draw $\triangle DEF$ with $\angle D = \angle A$ and $\angle E = \angle B$. For this, choose **Angle with Given Size** and click on E and D . In the window, give the size of the angle as α (the size of $\angle A$). Similarly click on D, E and give the size of angle as β (the size of $\angle B$) with **clockwise** selected. Join DE', ED' and mark their point of intersection as F . Mark the sides of both triangles. Are the ratios the same? Change the angles using sliders and see.

This can be stated in yet another way. We use the term scaling in comparing two measurements in terms of multiples. For example, in comparing a line of length 6 centimetres with a line of 4 centimetres, we say that the longer line is got by scaling the shorter by a factor of $1\frac{1}{2}$; and that shorter line is got by scaling the longer by a factor of $\frac{2}{3}$. We can say that the scale factor from the shorter to the longer is $1\frac{1}{2}$ and that from the longer to the shorter is $\frac{2}{3}$.

Using this terminology, our general principle can be stated thus:

In triangles with the same angles, sides opposite equal angles are scaled by the same factor

Now look at this problem:

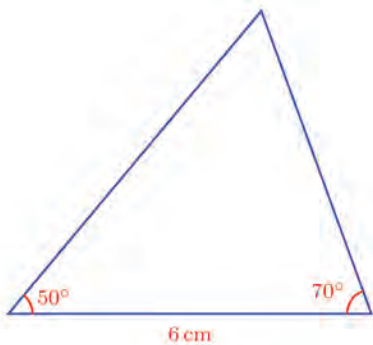

We want to draw a smaller triangle with all its sides $\frac{3}{4}$ of the sides of this triangle.

The bottom side of the new triangle should be 4.5 centimetres. What about the other two sides?

Should we first draw the larger triangle, measure its other two sides and draw a new triangle with sides $\frac{3}{4}$ of these?

We need only draw the same angles at the ends of the 4.5 centimetres long line, right?

Since the angles are all equal, the other two sides will also be $\frac{3}{4}$ of those of the larger triangle, by the general principle we have seen just now.

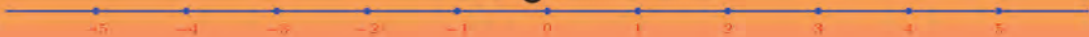
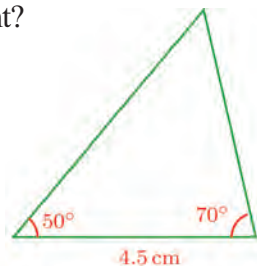

0 1 2 3 4 5 6 7 8 9

Let's look at another problem:

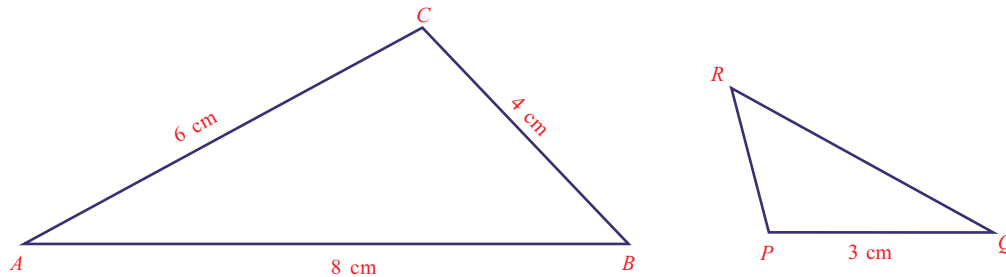

$$\angle P = \angle C \quad \angle Q = \angle A \quad \angle R = \angle B$$

How do we calculate the lengths of the other two sides of the small triangle?

First let's take the angles as x° , y° , z° and mark equal angles, as given in the picture:

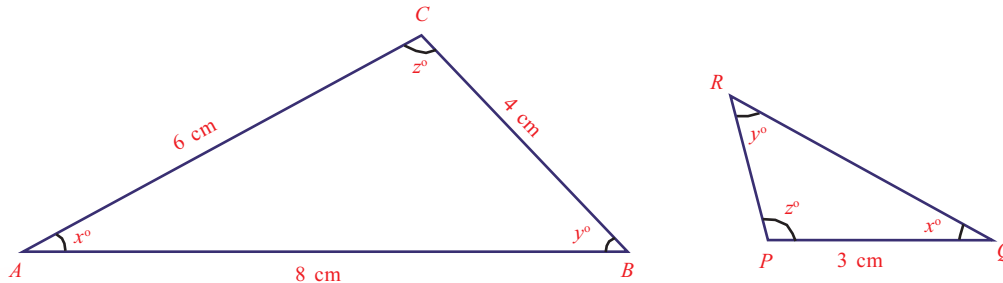

Then we write the pairs opposite equal angles:

$$x \quad BC \quad PR$$

$$y \quad AC \quad PQ$$

$$z \quad AB \quad QR$$

In this, we know the lengths of all sides of the large triangle and the length of one side of the small triangle:

$$x \quad BC = 4 \quad PR$$

$$y \quad AC = 6 \quad PQ = 3$$

$$z \quad AB = 8 \quad QR$$

We see that for the sides opposite the y° angle, the smaller is half the larger. So the sides opposite the other angles must also be related in the same manner:



$$\begin{aligned} x \quad BC &= 4 \quad PR = 2 \\ y \quad AC &= 6 \quad PQ = 3 \\ z \quad AB &= 8 \quad QR = 4 \end{aligned}$$

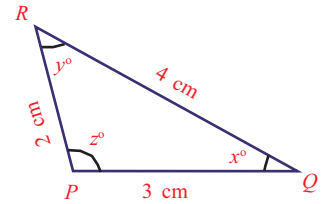
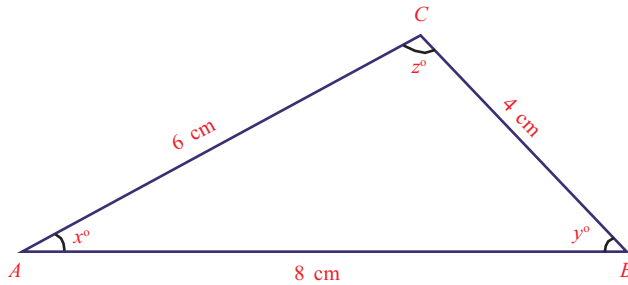

(1) The perpendicular from the square corner of a right triangle cuts the opposite side into two parts of 2 and 3 centimetres length.

- i) Prove that the two small right triangles cut by the perpendicular have the same angles.
- ii) Taking the length of the perpendicular as h , prove that $\frac{h}{2} = \frac{3}{h}$.
- iii) Calculate the perpendicular sides of the large triangle.
- iv) Prove that if the perpendicular from the square corner of a right triangle divides the opposite side into parts of lengths a and b and if the length of the perpendicular is h , then $h^2 = ab$.

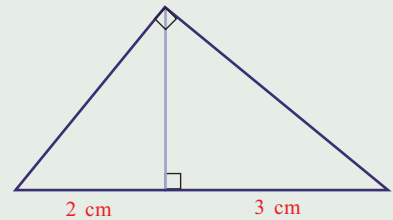

Draw right triangle ABC. Draw the perpendicular from the right corner to the hypotenuse and mark the point D where it meets the hypotenuse, with D as centre, draw the circle through C and mark the point E where the circle meets the perpendicular. Draw the square on AD and the rectangle of sides BD and DE. Mark their areas. Aren't they equal? Shift the corners of the right triangle and check.

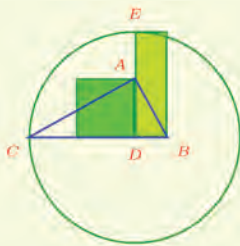

(2) At two ends of a horizontal line, angles of equal size are drawn, and two points on the slanted lines are joined:

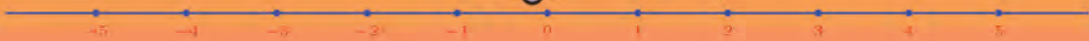
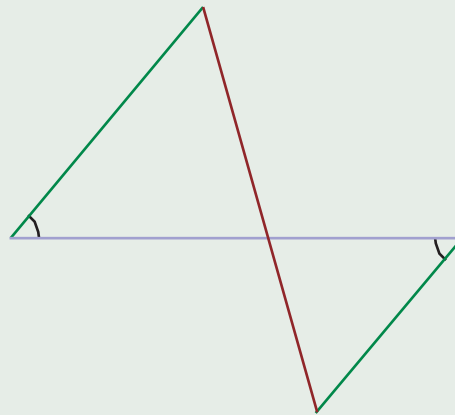

0 1 2 3 4 5 6 7 8 9

- i) Prove that the parts of the horizontal line and parts of the slanted line are in the same ratio.
 - ii) Prove that the two slanted lines at the ends of the horizontal line are also in the same ratio.
 - iii) Explain how a line of length 6 centimetres can be divided in the ratio 3 : 4 using this.
- (3) The midpoint of the bottom side of a square is joined to the ends of the top side and extended by the same length. The ends of these lines are joined and perpendiculars are drawn from these points to the bottom side of the square extended:

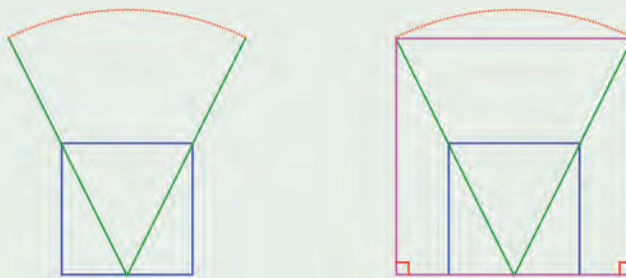

- i) Prove that the quadrilateral obtained thus is also a square.
- ii) Explain how we can draw a square with two corners on a semicircle and the other two corners on its diameter, as in the figure.

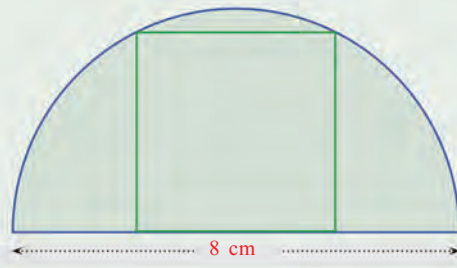

- (4) The picture shows a square drawn sharing one corner with a right triangle and the other three corners on the sides of this triangle.
- i) Calculate the length of a side of the square.
 - ii) What is the length of a side of the square drawn like this within a triangle of sides 3, 4 and 5 centimetres?

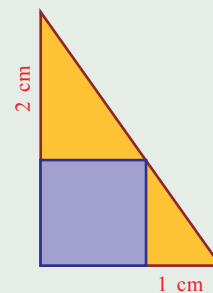



Make two sliders a, b with $\text{Min} = 0$. Draw a line AB and draw perpendiculars through its ends. Draw circles of radii a and b , centred at A and B . Mark the points C, D where the circles meet the perpendiculars. Join CB, AD and mark the point where it meets AB as F . Hide the circles and perpendiculars. Draw the line segments AC, FE, BD and mark their lengths. What is EF when $AC = 3$ and $BD = 2$? Change the length of AB and see. Check what happens when a and b are changed.

- (5) Two poles of heights 3 metres and 2 metres are erected upright on the ground and ropes are stretched from the top of each to the foot of the other.

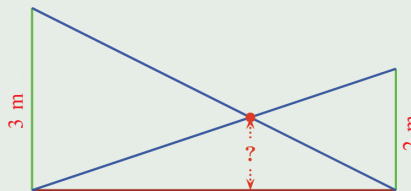

- i) At what height above the ground do the ropes cross each other?
- ii) Taking the heights of the poles as a and b and height above the ground of the point where the ropes cross each other as h , find the relation between a, b and h .
- iii) Prove that this height would be the same, whatever be the distance between the poles.

Sides and angles

We have seen that if two triangles have the same angles, then their sides are scaled by the same factor. This raises the question: if all the sides of a triangle are scaled (lengthened or shortened) by the same factor, would the angles remain the same?

See these triangles:

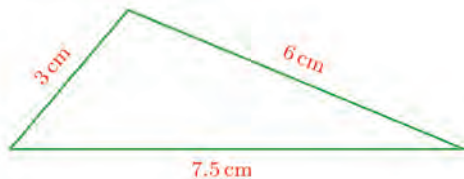
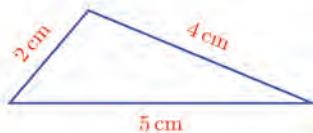

The sides of the larger triangle are all one and half times the sides of the smaller. Are the angles of the triangles the same?

To check this, mark the lengths of two sides of the small triangle on the sides of the large triangle and join these points as shown:

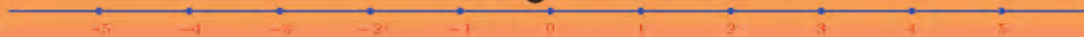
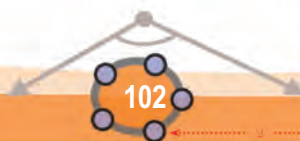
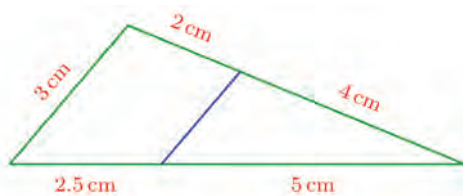

0 1 2 3 4 5 6 7 8 9

This line divides the bottom and right sides of the large triangle in the same ratio 1 : 2 and so it must be parallel to the left side. (The section, **Triangle division** of the lesson, **Parallel Lines**.) So these two lines are equally inclined to the bottom line:

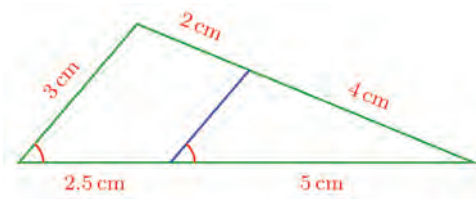

So if we just look at the larger triangle and the small triangle inside it (let's ignore the little triangle outside for the time being), we see that they have the same angles. So, by the general principle seen earlier, their sides are scaled by the same factor.

The bottom side of the small triangle is $\frac{2}{3}$ of that of the larger triangle; the right sides are also scaled by the same factor. Since all pairs of sides are scaled by the same factor, the left sides must also be scaled the same way. Thus we can calculate the third side of the small triangle:

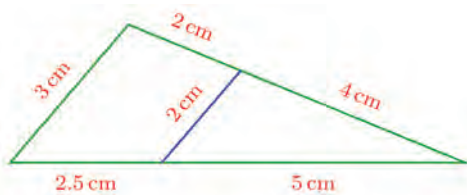

Now let's look again at the small triangle outside the larger which we had kept apart:

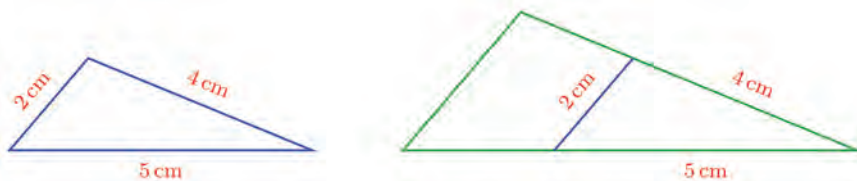

The small triangles in and out have sides of same length and so they have same angles also (The section **Sides and Angles** of the lesson, **Equal Triangles** in Class 8).

We have seen earlier that the angles of the large triangle are the same as the angles of the small triangle within.

So, what do we get?



0 1 2 3 4 5 6 7 8 9





The angles of the large and small triangles we started with are the same.

Even if we change the lengths of the sides and the scale factor in this example, we can show that the angles of the triangles are equal, using the same arguments as above.

For those who need greater precision, we can do it using general algebraic arguments.

Consider a triangle and another with its sides scaled by the same factor. This means, the lengths of the sides of one triangle are got from the lengths of the sides of the other by multiplication with the same number.

So, we can take the lengths of the sides of the smaller triangle as a, b, c and those of the larger as ka, kb, kc :



Draw triangle ABC with lengths of sides, say a, b, c . Make a slider k with $\min=0$. Draw a line DE with length ka . Draw circles centered at its ends with radii kb, kc . Mark the point F where they intersect. Draw triangle DEF. Aren't the angles of the two triangles the same? Change k and vertices of the first triangle and check.

Mark the perimeter and area of both triangles. How is the perimeter scaled? And the area?

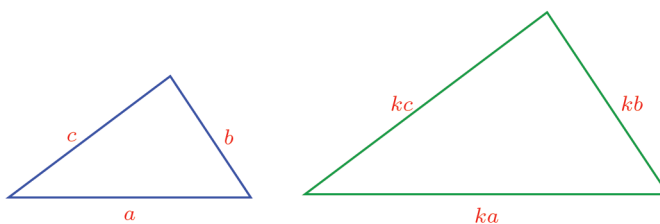

As in the example, mark the lengths of two sides of the smaller triangle on the sides of the larger and join these points:

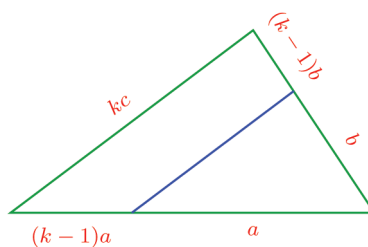

This line divides the bottom and right sides of the large triangle in the same ratio $k-1 : 1$. So, this line is parallel to the left side of the large triangle. From this we can see that the large triangle and the smaller one within have the same angles. This implies their sides are scaled by the same factor. The bottom side of the small triangle within is $\frac{1}{k}$ of the bottom side of the larger triangle; the

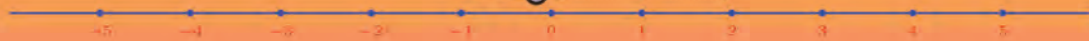

0 1 2 3 4 5 6 7 8 9



right sides are also scaled by the same factor. So the left sides must also be scaled the same way:

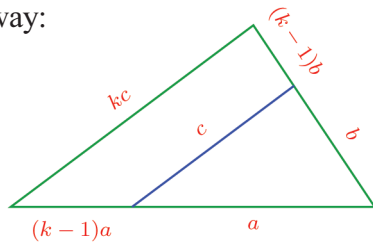

Now let's compare the small triangles inside and outside the larger one, as in our example earlier:

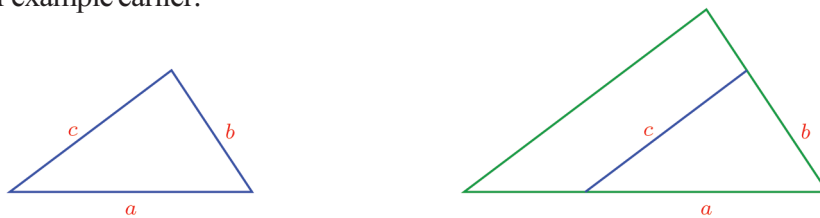

Since the lengths of the sides of these two triangles are the same, the angles must also be the same. We have also seen earlier that the angles of the large triangle and those of the smaller triangle within it are the same. So, the small and large triangles we started with have the same angles.

If the sides of two triangles are scaled by the same factor, then their angles are the same

So to transform a triangle into a smaller or larger one without changing angles, we need not measure the angles, we need only scale the sides by the same factor.

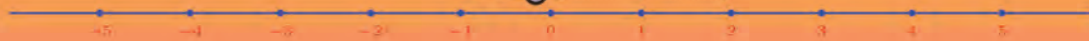
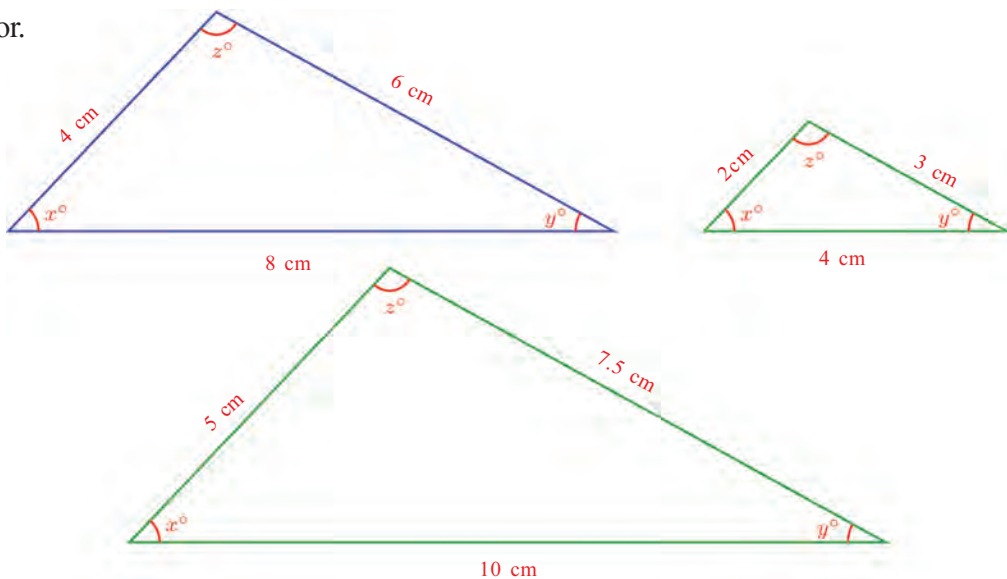



Let's look at a problem based on this. We can easily see that if the sides of a triangle are scaled by the same factor, then their perimeters are also scaled by the same factor. (Try it!)

How are the areas related? To see this, let's draw two such triangles. By what we have seen just now, they have the same angles. To compare the areas, let's draw perpendiculars from two vertices with the same angles.

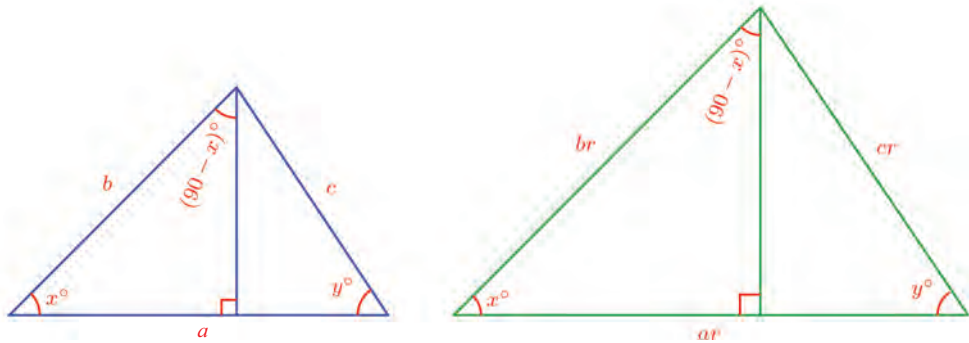

Look only at the right triangles on the left of each. Both have angles x° , 90° and $(90 - x)^\circ$. So their sides are scaled by the same factor. The hypotenuse of the blue right triangle is b and that of the green right triangle is br . So if we take the perpendicular in the blue triangle as h , the perpendicular in the green triangle is hr .

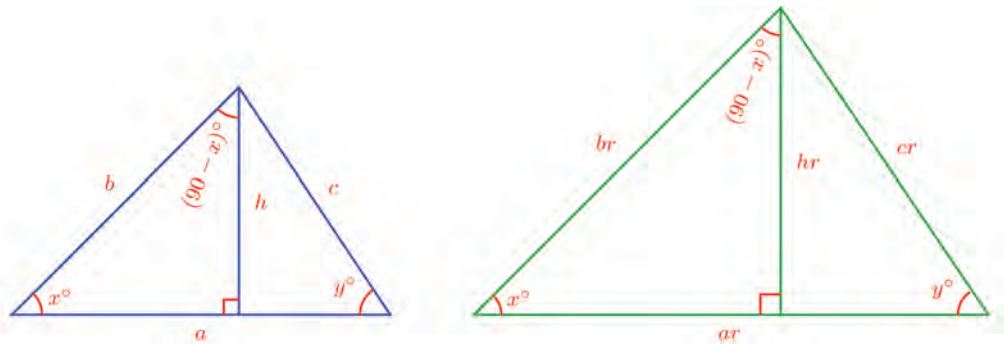

Now we can compute the areas of both the whole triangles. The area of the blue triangle is $\frac{1}{2}ah$ and the area of the green triangle is $\frac{1}{2}ahr^2$.

Thus the scale factor of areas is the square of the scale factor of the sides.

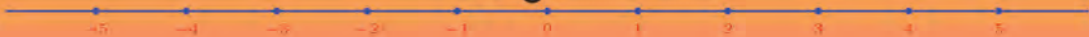

0 1 2 3 4 5 6 7 8 9



- (1) Draw a triangle of angles the same as those of the triangle shown and sides scaled by $1\frac{1}{4}$.

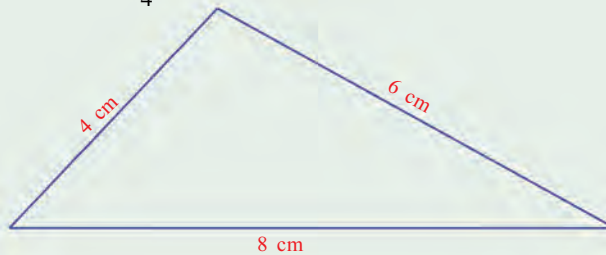

- (2) See this picture of a quadrilateral.

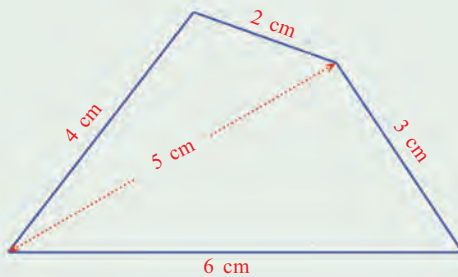

- i) Draw a quadrilateral with angles the same as those of this one and sides scaled by $1\frac{1}{2}$.
- ii) Draw a quadrilateral with angles different from those of this and sides scaled by $1\frac{1}{2}$.

Triangle speciality

If the angles of a triangle are equal to the angles of another, then their sides are in the same ratio. And conversely, if the sides of two triangles are in the same ratio, then their angles are equal. Among polygons, only triangles have this property.

The third way

If we know one side of a triangle and the angles at its ends, the first part of our discussion shows how we can scale it without altering its angles. Scale the known side and draw the same angles at its ends. The other sides would be scaled by the same factor.

If what we know are the lengths of the three sides, then the second part of the discussion shows how it can be scaled. Just scale all sides by the same factor; the angles would remain the same.

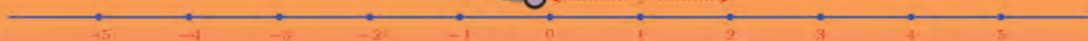

0 1 2 3 4 5 6 7 8 9





Now suppose what we know are the two sides of the triangle to be scaled and the angle between them. For example, see the triangle on the right.

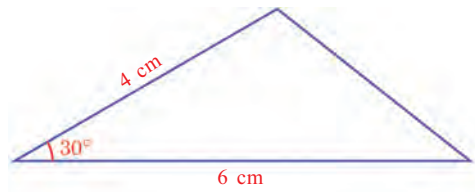

We want to scale it by $\frac{3}{4}$.

We can draw a triangle of sides $\frac{3}{4}$ of 6 and 4 centimetres and the angle between them as 30° .

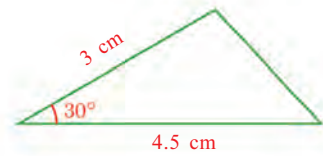
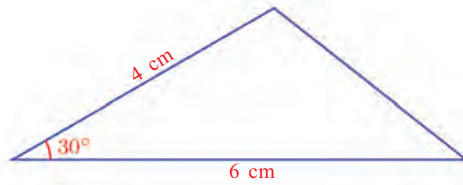

But we don't know whether the third side also is $\frac{3}{4}$ the third side of the first triangle.

To check this, cut out cardboard triangles like these and place the smaller over the larger, with the left corners together, as we did in the first part of the lesson. Since the angles are equal, the sides at these corners would be aligned:

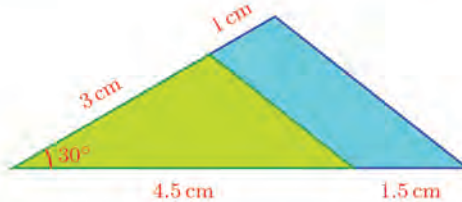
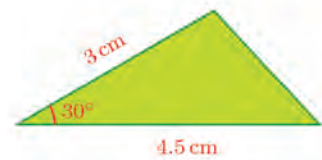
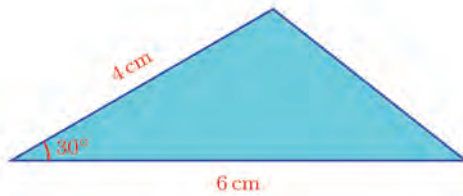

Now the right side of the green triangle divides the left and bottom sides of the blue triangle in the same ratio and so it is parallel to the right side of the

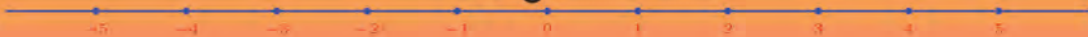

0 1 2 3 4 5 6 7 8 9



large triangle. So, the right sides of the triangles are equally inclined to the bottom side:

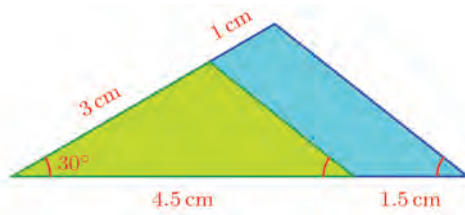

Thus we see that the two triangles have the same angles. So, their sides are scaled by the same factor; which means the right side of the small triangle is also $\frac{3}{4}$ of the right side of the large triangle.

Even if the measures and the scale factor are changed, we can use the same arguments as above to reach this conclusion:

In triangles with two sides scaled by the same factor and the angle between them the same, the third sides are also scaled by the same factor

Using this, we can scale a triangle without measuring sides or angles. For example, draw a triangle like this.

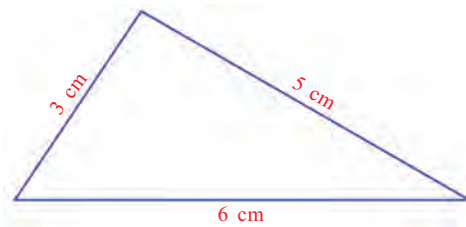

Mark some point inside the triangle and join it to the ends of the bottom side.

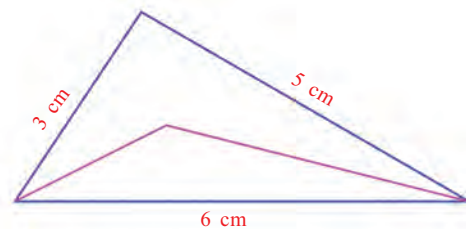

Extend each of these lines by its half and join the ends.

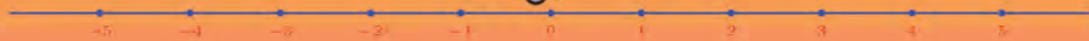
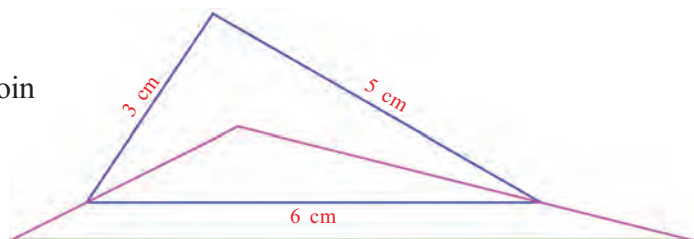



We can scale triangles in GeoGebra like this. Draw $\triangle ABC$ and mark a point D inside or outside the triangle. Draw lines from D to A, B, C using **Ray From a Point**. Make a slider g with **Min = 0** and draw circles centred at D with radii $g * AD, g * BD, g * CD$ and mark the points where these lines meet AD, BD, CD as E, F, G . Hide the circles and draw the triangle EFG . Move the slider and see what happens. What do you see when $g = 1$?, When $g = 0.5$? $g = 2$? Change the position of D and see what you get.

Now we have a new triangle and a small one inside it. The left and right sides of the large triangle are one and a half times those of the small triangle; and the angle between these is the same for both triangles. So, the third side of the large triangle also is one and a half times the third side of the small triangle.

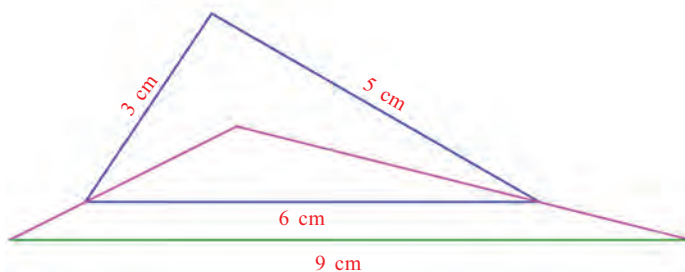

Join the point inside the triangle and the other vertex and extend as before. What do we get?

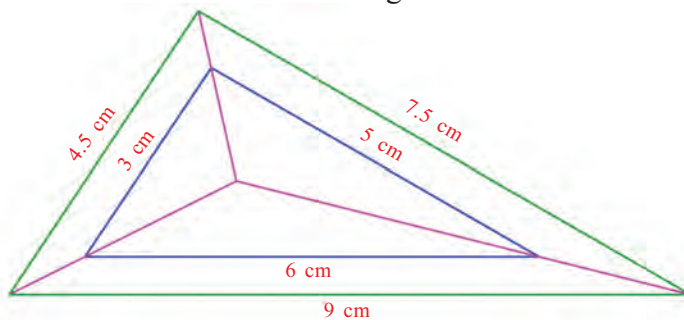

All sides of the large triangle are one and a half times that of the original triangle, right?

Two triangles of sides scaled by the same factor are called *similar*. By the general principles we have seen:

For two triangles to be similar, they have to be related in one of the following ways:

- Having the same angles.
- Having sides scaled by the same factor .
- Having two sides scaled by the same factor and the angles between them equal.



To draw similar triangles in GeoGebra. We can use **Dilate from Point**. Make a slider a with **Min = 0**. Draw a triangle and mark a point inside it or outside it. Choose **Dilate from Point** and click on the triangle and the point. In the new window give a as **Scale Factor**. We get a triangle similar to the first one. Move the slider to change a and see what happens. The position of D may also be changed. We can draw similar shapes of any shape like this.



0 1 2 3 4 5 6 7 8 9



- (1) The picture shows two circles with the same centre and two triangles formed by joining the centre to the points of intersection of the circles with two radii of the larger circle:

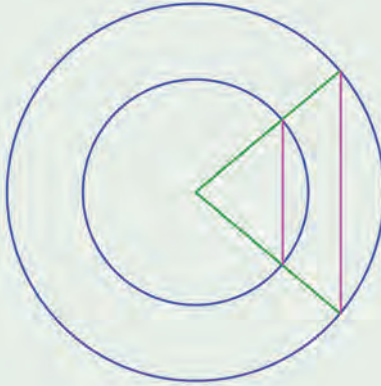

Prove that these triangles are similar.

- (2) The lines joining the circumcentre of a triangle to the vertices are extended to meet another circle with the same centre, and these points are joined to make another triangle.

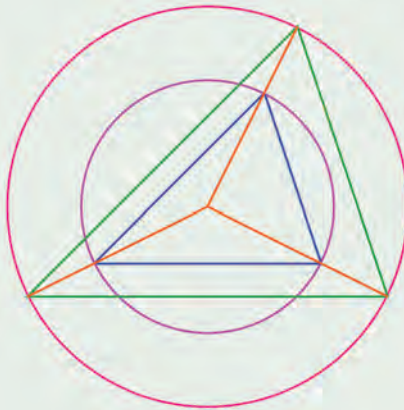

- i) Prove that the two triangles are similar.
- ii) Prove that the scale factor of the sides of the triangle is the scale factor of the radii of the circles.

0 1 2 3 4 5 6 7 8 9

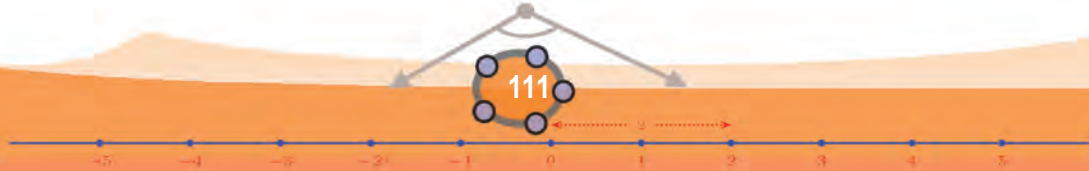



An old shadow math

Haven't you heard the story of how the Greek mathematician Thales determined the distance to a ship at sea, using the idea of equality of triangles?

There's another tale about Thales. The king of Egypt is supposed to have asked Thales to compute the height of a pyramid. Thales' method is recorded like this. "Planting his staff at the end of the shadow of the pyramid, he showed that in the two triangles made by sun rays, the ratio of the shadows is the same as the ratio of the staff and the pyramid".

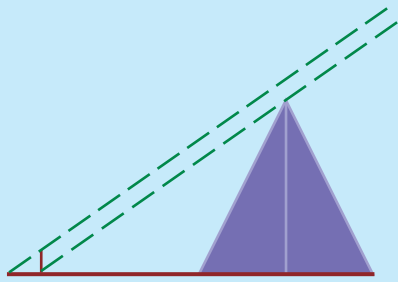

- (3) A point inside a quadrilateral is joined to its vertices and the lines are extended by the same scale factor. Their ends are joined to make another quadrilateral.

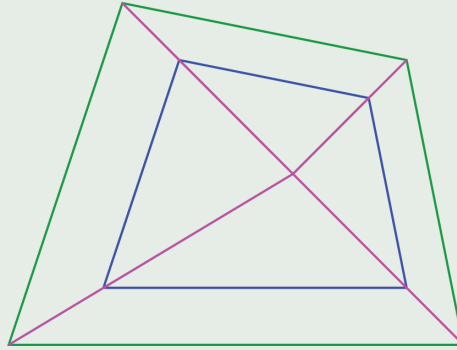

- i) Prove that the sides of the two quadrilaterals are scaled by the same factor.
- ii) Prove that the angles of the two quadrilaterals are the same.



Draw quadrilateral ABCD and mark a point E within it. Make a slider k with $\text{Min} = 0$. Use the Ray tool to draw the line from E passing through A. Draw the circle centred at E with radius given as $k \cdot EA$ and mark the point F where it meets this line. Like this, draw rays EB, EC, ED and circles of radii $k \cdot EB$, $k \cdot EC$, $k \cdot ED$ and mark the points G, H, I where they meet the lines. Draw the quadrilateral FGHI. Mark the lengths of the sides of the two quadrilaterals and find the relation between them. Mark the angles of the quadrilaterals. Shift the vertices of the first quadrilateral and change the value of k and see the result.



Project

In similar triangles, how are the angle bisectors, medians and the circumradii related?



0 1 2 3 4 5 6 7 8 9