

PHYSICS

Standard X
Part-1



Government of Kerala
Department of General Education

State Council of Educational Research and Training
(SCERT) Kerala
2019

THE NATIONAL ANTHEM

Jana-gana-mana adhinayaka jaya he
Bharatha-bhagya-vidhata,
Punjab-Sindh-Gujarat-Maratha
Dravida-Utkala-Banga
Vindhya-Himachala-Yamuna-Ganga
Uchchala-Jaladhi-taranga
Tava subha name jage,
Tava subha asisa mage,
Gahe tava jaya gatha.
Jana-gana-mangala-dayaka jaya he
Bharatha-bhagya-vidhata,
Jaya he, jaya he, jaya he,
Jaya jaya jaya jaya he!

PLEDGE

India is my country. All Indians are my brothers and sisters.

I love my country, and I am proud of its rich and varied heritage. I shall always strive to be worthy of it.

I shall give my parents, teachers and all elders respect, and treat everyone with courtesy.

To my country and my people, I pledge my devotion. In their well-being and prosperity alone lies my happiness.

State Council of Educational Research and Training (SCERT)

Poojappura, Thiruvananthapuram 695012, Kerala

Website : www.scertkerala.gov.in, e-mail : scertkerala@gmail.com

Phone : 0471 - 2341883, Fax : 0471 - 2341869

Typesetting and Layout : SCERT

Printed at : KBPS, Kakkanad, Kochi-30

© Department of Education, Government of Kerala

Dear students,

You were provided with opportunities to observe your surroundings and engage in simple experiments and investigative activities in earlier classes. The classroom experience, undoubtedly, might have helped you to record the information systematically and assimilate ideas through discussion and analysis. While understanding the scientific approach, there should also be the attitude to take forward the skills to apply them in day-to-day life. Moreover, an eco-friendly perspective must be adopted too. All these, through direct experiences, enquiry and understanding preferably. This textbook presents ideas in accordance with this.

'Samagra', the education portal and technology enabled QR Code printed textbooks would definitely make your learning activity in classrooms easy and joyful. The National Skills Qualifications Framework, the current relevance of Disaster Management and the possibilities of ICT have also been considered while modifying the textbook.

Go ahead, thinking, asking questions, approaching ideas critically and quizzing with teachers and friends.

Make learning a joyful experience.

Regards,

Dr. J. Prasad
Director, SCERT

CONSTITUTION OF INDIA

Part IV A

FUNDAMENTAL DUTIES OF CITIZENS

ARTICLE 51 A

Fundamental Duties- It shall be the duty of every citizen of India:

- (a) to abide by the Constitution and respect its ideals and institutions, the National Flag and the National Anthem;
- (b) to cherish and follow the noble ideals which inspired our national struggle for freedom;
- (c) to uphold and protect the sovereignty, unity and integrity of India;
- (d) to defend the country and render national service when called upon to do so;
- (e) to promote harmony and the spirit of common brotherhood amongst all the people of India transcending religious, linguistic and regional or sectional diversities; to renounce practices derogatory to the dignity of women;
- (f) to value and preserve the rich heritage of our composite culture;
- (g) to protect and improve the natural environment including forests, lakes, rivers, wild life and to have compassion for living creatures;
- (h) to develop the scientific temper, humanism and the spirit of inquiry and reform;
- (i) to safeguard public property and to abjure violence;
- (j) to strive towards excellence in all spheres of individual and collective activity so that the nation constantly rises to higher levels of endeavour and achievements;
- (k) who is a parent or guardian to provide opportunities for education to his child or, as the case may be, ward between age of six and fourteen years.



Content

1. Effects of Electric Current 07
2. Magnetic Effect of Electric Current 33
3. Electromagnetic Induction 45
4. Reflection of Light 79

Certain icons are used in this
textbook for convenience



*For further reading
(Evaluation not required)*



*ICT possibilities for making
concepts clear*



Let us assess



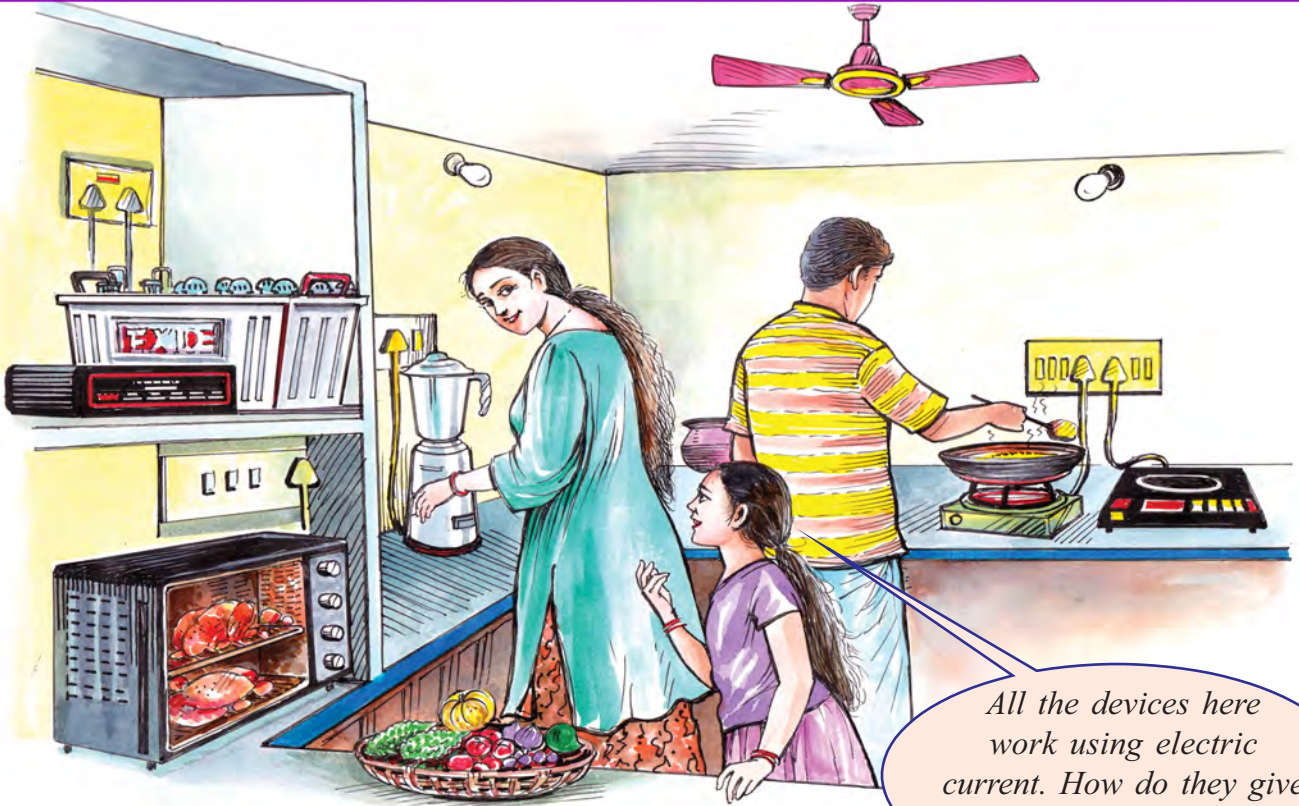
Extended activities



NSQF

1

Effects of Electric Current



All the devices here work using electric current. How do they give different forms of energy!

Have you also felt the same doubt? Some electrical devices are shown in the house of the child. What are they?

Let's try to write them down.

- Electric bulb
- Electric fan
-
-
-
-
-

It is electrical energy that is given to the devices. But don't they give us different forms of energy? Write down the energy changes in them with respect to their use.

Device	Use	Energy change
• Electric bulb →
• Induction cooker	To get heat	Electrical energy → Heat
• Storage battery (while charging) →
• Mixie →
• →
• →

Table 1.1

It is clear from the table that electrical energy can be transformed into different forms of energy.

The useful form of energy into which a device converts electrical energy, is considered as the effect of electric current on that device.

- We are familiar with so many electrical devices in our daily life. Write down in your science diary the effect of electric current on each of them.

You might have studied in your chemistry class the chemical effect of current. Now we shall learn more about the heating and the lighting effects of electricity.

Heating effect of electric current

Among those we use in daily life, which are the devices that give heating effect of electric current?

- Electric iron
-
-

How does electrical energy change into heat energy in such devices?

Let's do an experiment.

Materials required:

- A nichrome wire of approximate length 5 cm
- 6 V storage battery
- Connection wires

Construct a circuit as shown in Fig. 1.1

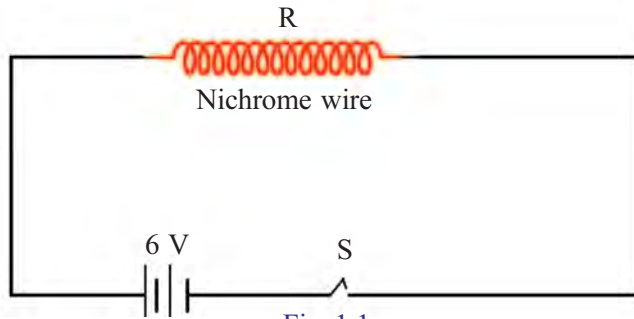


Fig. 1.1

How does the nichrome wire become red hot while passing electricity through the circuit?

Analyse this based on the concept that energy can neither be created nor destroyed. It can only be converted from one form to another (Law of Conservation of Energy)

In this case which form of energy was converted into heat energy?

How does this energy change occur?

Let's analyse by examining the current and voltage in the circuit.

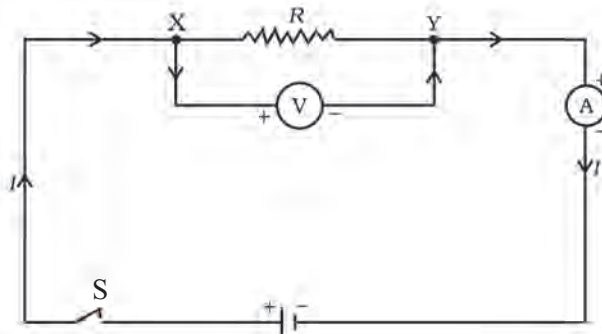


Fig. 1.2

We can measure the voltage between the ends of the resistor R (nichrome wire) using a voltmeter V and the current through it, using an ammeter A.

If the ammeter shows a current I ampere on applying a potential difference V across the resistor of resistance R Ω ,

$$\text{Current } I = \frac{Q}{t}$$

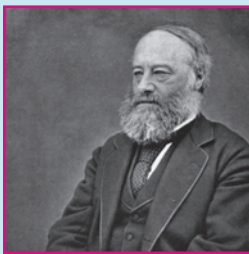
Then, the charge that flows through the conductor in t second,
 $Q = \dots\dots\dots$ coulomb.

The potential difference between two points will be one volt if one joule of work is done in moving one coulomb of charge from one point to the other.



James Prescott Joule and Joule's Law

The English scientist James Prescott Joule, born in 1818, conducted studies about the salient features of heat energy and about the mechanical movements caused by heat.



He became famous for his two laws related to the magnitude of heat due to current and how the energy of gas influences pressure, volume and temperature.

One joule of work is required to move one coulomb of charge under one volt potential difference. Hence the work W to be done to move one coulomb of charge under a potential difference V will be, $W = V$ joule.

If so, the work to be done to move a charge Q under a potential difference V is $W = QV$. The work required for moving the electric charge through the conductor is done by the battery connected to the circuit. The power P supplied

by the battery to the circuit in a time t second is $P = \frac{W}{t}$.

On substituting the equation of work in this we get

$$P = \frac{V \times Q}{t}$$

$$I = \frac{Q}{t}$$

ie, $P = VI$.

Therefore the energy supplied by the battery to the circuit in t second = $Pt = VIt$.

The electrical energy expended by the battery in the circuit containing the nichrome wire is converted into heat.

Therefore $H = VIt$

The heat is developed since a current is available in the circuit in accordance with the voltage applied.

If so why did the nichrome wire in the circuit alone become red hot? Let's examine the influence of resistance in changing the electrical energy into heat energy.

According to Ohm's Law, $V = IR$. On substituting this in the equation $H = VIt$

$$\begin{aligned} H &= IR(It) \\ &= I^2Rt \end{aligned}$$

From this it can be understood why the nichrome wire alone becomes red hot. This process by which heat is developed in a circuit on passing current through it is known as the Joule Heating or Ohmic Heating.

Haven't you understood the factors influencing the heat developed when a current passes through a conductor?

Joule's Law

The heat generated (H) in a current carrying conductor is directly proportional to the product of the square of the current (I) in the conductor, the resistance of the conductor (R) and the time (t) of flow of current.

$$H \propto I^2Rt \quad \therefore H = I^2Rt \text{ joule}$$

I is the current in ampere, R is the resistance in ohm and t is the time in second.

Complete the following table on the basis of Joule's Law.

Resistance of conductor $R(\Omega)$	Intensity of Current $I(A)$	Time for which current flows $t(s)$	Heat generated $I^2Rt(J)$	Change in Heat (H)
$2R$	I	t	$2I^2Rt$	Twice ($2H$)
R	$2I$	t
$R/2$	I	t
R	$I/2$	t
R	I	$2t$
R	I	$t/2$



Table 1.2

Analyse the table and find out the factor that influences heat the most.

Don't you now understand how the change in current, resistance and the time for which electricity flows influence the amount of heat developed?

Let's do an experiment to observe the relation between the heat developed according to Joule's Law and the current (I), resistance (R) and the time for which the current flows (t).

A and B are two beakers of 200 mL capacity. Each beaker contains 100 mL of water. PQ is a nichrome wire. RS is a copper wire of the same length and diameter as the nichrome wire.

Measure the temperature of water in the beakers A and B using a thermometer. When switched on, isn't it the same current that passes through PQ and RS? Observe the ammeter reading. Measure the temperatures of water in the two beakers after three or four minute. Repeat the experiment by changing the current and the time.

- Of the water in beakers A and B which one got heated more? Why?
- What change is observed in the temperature of water in both the beakers when the current is increased using the rheostat?
- What was the change that happened to the temperature of water in both the beakers on increasing the time?

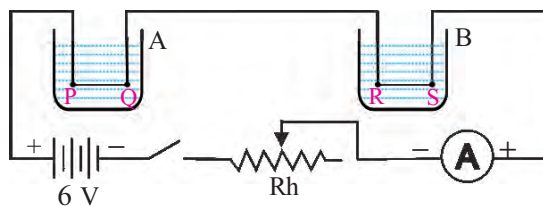


Fig. 1.3

Joule’s Law is useful in devices that make use of heating effect of electricity.

Let’s solve some mathematical problems which are related to Joules Law.

- How much will be the heat developed if 0.2 A current flows through a conductor of resistance 200 Ω for 5 minute?

$\therefore H = I^2Rt$	$R = 200 \Omega$
$= (0.2)^2 \times 200 \times 300$	$I = 0.2 \text{ A}$
$= 2400 \text{ J}$	$t = 5 \times 60 \text{ s}$
	$= 300 \text{ s}$

$\therefore \text{Heat generated} = 2400 \text{ J}$

If 4.2 J is one calorie then $H = \dots\dots\dots$ calorie

$H = I^2Rt$ is used to find out the heat developed when current flows through a conductor. Let’s try to write down the equation in some other forms as well.

According to Ohm’s Law, $I = V/R$. If we substitute this in the equation according to Joule’s Law $H = I^2Rt$, we get

$$H = (V/R)^2Rt$$

$$H = \left(\frac{V}{R}\right)^2 Rt$$

$= \dots\dots\dots$

- Let’s find out the heat developed in 3 minute by a device of resistance 920 Ω working under 230 V

$V = 230 \text{ V}$	Try to solve the problem
$R = 920 \Omega$	in another way
$t = 3 \times 60 \text{ s}$	$V = 230 \text{ V}, R = 920 \Omega$

On using the given values

$H = \frac{V^2t}{R}$	$I = \frac{V}{R} = \dots\dots\dots$
$= \frac{230^2 \times 3 \times 60}{920}$	$H = I^2Rt$
$H = 10350 \text{ J}$	$= \dots\dots\dots$
	$H = \dots\dots\dots \text{J}$

Is there any difference in the amount of heat energy thus obtained?

Note down in the science diary how this problem can be solved using the relation, $H = VI t$.

Let's calculate the heat developed when 3 A current flows through an electric iron box designed to work under 230 V. Which equation will help us to solve the problem easily? Solve the problem.

Details of two electric heaters are given below. How much will be the heat developed if they are made to work for 5 minute each?

Heater - A	Heater - B
Working voltage : 230 V	Working voltage : 230 V
Resistance : 1150 Ω	Resistance : 460 Ω
Working time : 5 minute	Working time : 5 minute
$H = \frac{V^2 t}{R}$ $= \frac{230^2 \times 300}{1150}$ $= 13800 \text{ J}$	$H = \frac{V^2 t}{R}$ $= \frac{230^2 \times 300}{460}$ $= 34500 \text{ J}$

Table 1.3

- Why does the heater having low resistance get heated more?
- In which way does the change in resistance influence the heat developed?
- Find out the current in the heaters A and B and compare the heat developed.
- How do the resistors bring about a change in the current in the circuit?

Let's take a look at how the voltage and current changes when resistors are arranged in different ways in circuits.

Arrangement of Resistors in Circuits

Two different circuits which can be constructed using a 6 V- 2 A battery, 3 W-6 V bulbs and a switch are given (Fig 1.4). Construct these circuits and operate it. Write down the answers based on your observations.

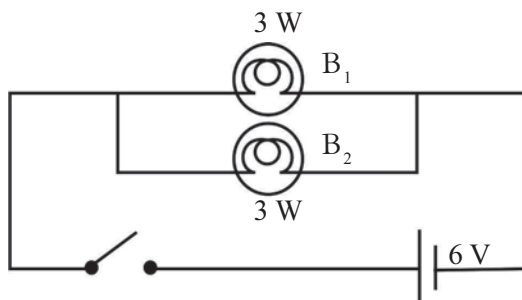
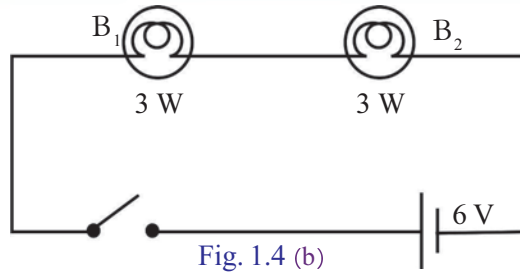
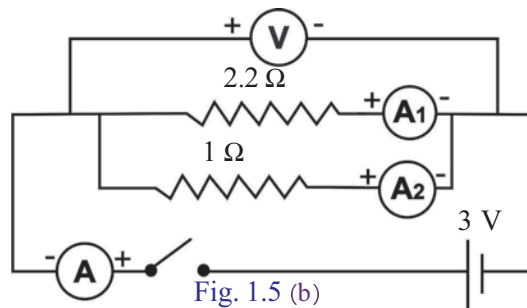
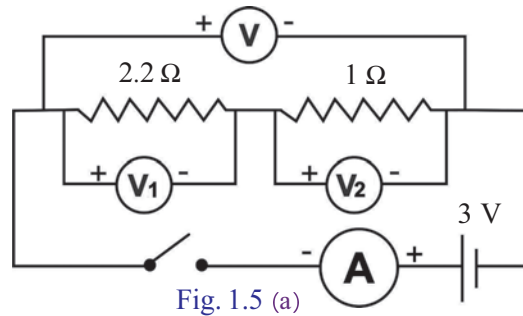


Fig. 1.4 (a)



- In which circuit does the bulb glow with high intensity?
- Remove one bulb from each circuit. What do you observe?
 In fig 1.4 (a)
 In fig 1.4 (b)
- Why do the bulbs in Fig 1.4 (a) glow with maximum brightness?
 Draw a suitable circuit with ammeter and voltmeter in the circuit replacing the bulbs by $1\ \Omega$, $2.2\ \Omega$ resistors. Compare the circuit you have drawn with the one given below and construct it properly. Record the readings in the table.



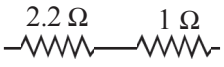
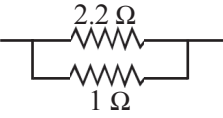
Mode of connection of resistances	Voltage obtained in resistance (V)			Current in resistances (I)			Effective Resistance (by analysing the current)
	2.2 Ω V ₁	1 Ω V ₂	Effective voltage V	2.2 Ω I ₁	1 Ω I ₂	A I	
							
							

Table 1.4

Analyse the table and tick (✓) the best suited.


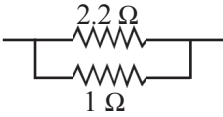
Mode of connection of resistances	Effective Resistance	Voltage obtained in each resistance	Current through each resistance
	increases/ decreases	same / different	same / different
	increases/ decreases	same / different	same / different

Table 1.5

Series Connection

When a circuit is completed by connecting the resistors one after the other, it is called series connection. When resistors are connected like this, the effective resistance increases.



Fig. 1.6

When resistors are connected in series, the potential difference gets divided.

$$V = V_1 + V_2$$

The current through each resistor will be the same. Hence

$$V_1 = IR_1, V_2 = IR_2$$

In a series circuit the voltage across the higher resistance will be greater.

According to Ohm's Law, $V = IR$. Here R indicates the effective resistance.

Hence



Colour Code

The value of resistance of carbon resistors available in the market has their resistance directly marked on them or indicated by colour codes. Usually rings of four different colours are used. The first two rings indicate the two digits, the third one indicates the number of zeroes and the fourth ring indicates tolerance (*deviation*). Silver $\pm 10\%$, gold $\pm 5\%$, and if there is no fourth line, then $\pm 20\%$ deviation will be there.

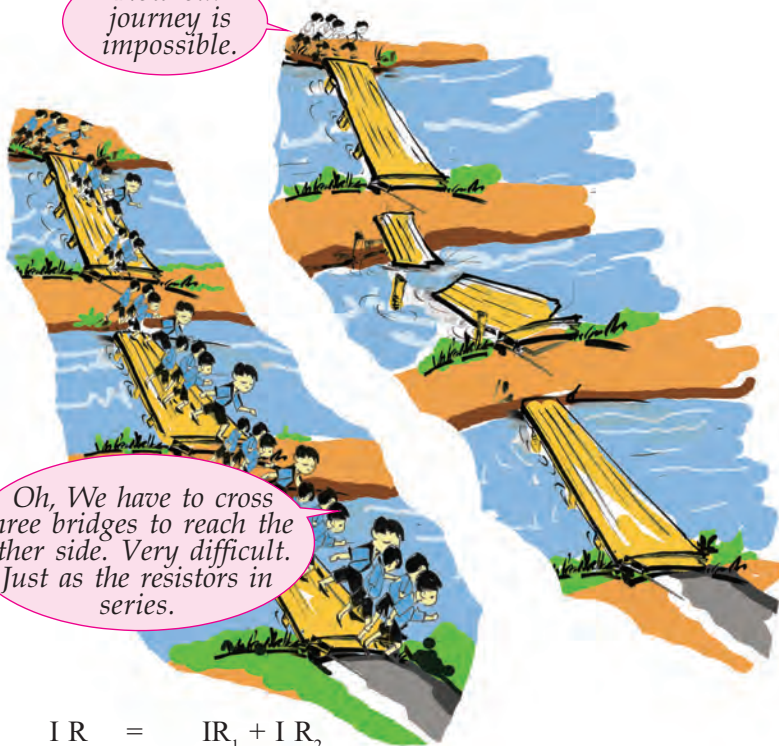


For example, if the first two rings are red and violet, then the first two digits are 2 and 7. The third one denotes the number of zeroes. If this is orange, then there are three zeroes. Now the value is 27000Ω . If the silver ring is also considered then the value = $27 \text{ k}\Omega \pm 10\%$.

Colour	Number	No. of Zeros
Black	0	0
Brown	1	1
Red	2	2
Orange	3	3
Yellow	4	4
Green	5	5
Blue	6	6
Violet	7	7
Grey	8	8
White	9	9

Now our journey is impossible.

Oh, We have to cross three bridges to reach the other side. Very difficult. Just as the resistors in series.



$$I R = I R_1 + I R_2$$

$$I R = I (R_1 + R_2)$$

$$R = R_1 + R_2$$

Effective resistance is the sum of the resistance of all the resistors when they are connected in series. If the resistors are of the same value, then the effective resistance can be obtained by multiplying the resistance of a resistor with the number of resistors.

Parallel Connection

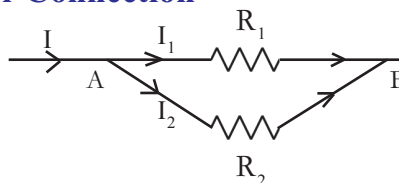


Fig 1.7

The current completes the circuit by getting divided into each branch since the resistors are connected in parallel. The total current in the circuit is the sum of the current through all the branch circuits.

$$I = I_1 + I_2$$

Since R is the effective resistance,

By Ohm's Law
$$\frac{V}{R} = \frac{V}{R_1} + \frac{V}{R_2}$$

$$V\left(\frac{1}{R}\right) = V\left(\frac{1}{R_1} + \frac{1}{R_2}\right)$$

$$\frac{1}{R} = \frac{1}{R_1} + \frac{1}{R_2}$$

$$R = \frac{R_1 R_2}{R_1 + R_2}$$

If resistors of the same value are connected in parallel, then $R = \frac{r}{n}$, where n is the number of resistors and r is the resistance of one resistor.

Complete Table 1.6 by analysing Tables 1.4 and 1.5.

Resistors in series	Resistors in parallel
<ul style="list-style-type: none"> Effective resistance increases 	<ul style="list-style-type: none">
<ul style="list-style-type: none"> 	<ul style="list-style-type: none"> The current through each resistor is different. It gets divided as per the value of resistors.
<ul style="list-style-type: none"> The potential difference across each resistor is different. It gets divided as per the value of resistors. 	<ul style="list-style-type: none">
<ul style="list-style-type: none"> 	<ul style="list-style-type: none"> Each resistor can be controlled by using separate switches.

Table 1.6

- What is the current if 4Ω and 2Ω resistors are connected in series and 6 V potential difference is applied ?

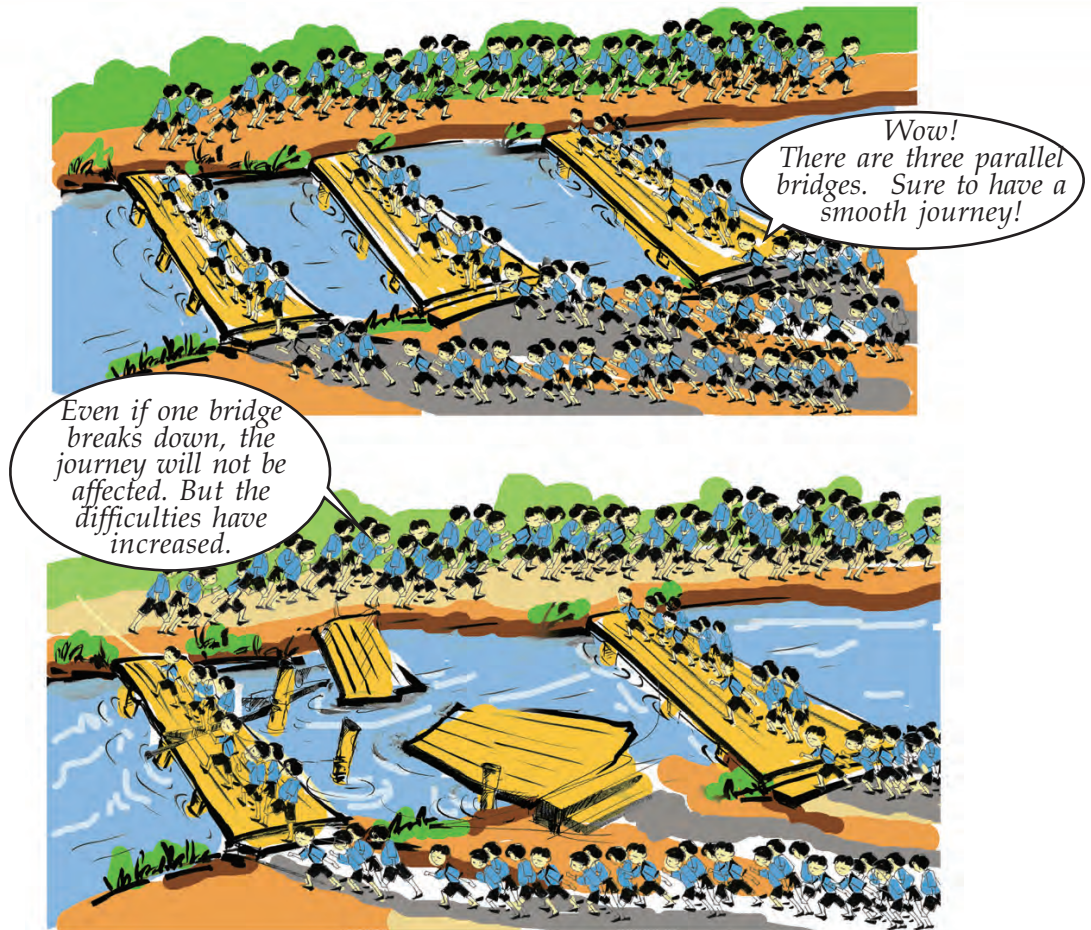
$$V = 6 \text{ V}$$

$$\begin{aligned} R &= R_1 + R_2 \\ &= 4 + 2 = 6 \Omega \end{aligned}$$

$$R = \frac{V}{I}$$

$$6 = \frac{6}{I}$$

$$\text{Current } I = \frac{6}{6} = 1 \text{ A}$$



- What is the current if $12\ \Omega$ and $4\ \Omega$ resistors are connected in parallel and $12\ \text{V}$ potential difference is applied?

$$R_1 = 12\ \Omega, R_2 = 4\ \Omega, V = 12\ \text{V}$$

$$\frac{1}{R} = \frac{1}{R_1} + \frac{1}{R_2}$$

$$\frac{1}{R} = \frac{1}{12} + \frac{1}{4} = \frac{4 + 12}{12 \times 4} = \frac{16}{48}$$

$$R = \frac{48}{16} = 3\ \Omega$$

$$\text{current } I = \frac{V}{R} = \frac{12}{3} = 4\ \text{A}$$

$$V = 12\ \text{V}$$

$$R = \frac{R_1 R_2}{R_1 + R_2}$$

$$= \frac{12 \times 4}{12 + 4}$$

$$= \frac{48}{16} = 3\ \Omega$$

$$\text{Current } I = \frac{V}{R} = \frac{12}{3} = 4\ \text{A}$$

OR

- 10 resistors of $2\ \Omega$ each are connected in parallel. Calculate the effective resistance.

When the voltage is constant, current will decrease with an increase in resistance. Won't this help you in explaining why the heat decreases even after increasing the resistance?

We can bring about change in current and voltage by connecting resistors in different ways. Now you would have understood why it is stated in Joule's Law that heat is directly proportional to resistance only when the current and time are constant?

Heating Effect of Electricity- Uses

Electric heating appliances are instruments that make use of the heating effect of electricity. Electrical energy is converted into heat energy in them.



Fig 1.8

A few heating appliances are shown in the figure. Examine any one of them and answer the following questions. Record the answers in the science diary.

- Name the part in which electrical energy changes into heat energy.
- Which material is used to make this part?
- What are the peculiarities of such substances?
 - high resistivity
 - ability to remain in red hot condition for a long time without getting oxidised
 -
 -



Appliances without heating coil



Microwave oven

Induction cooker

Microwave oven and induction cooker are appliances which do not use a heating coil. In a microwave oven, microwaves are used and induction cooker uses eddy currents.



Fig 1.9

Short Circuit and Overloading

If the positive and the negative terminals of a battery or the two wires from the mains come into contact without the presence of a resistance in between, they are said to be short-circuited.

A circuit is said to be overloaded if the total power of all the appliances connected to it is more than what the circuit can withstand.

Heating coils are made of nichrome. Nichrome is an alloy of nickel, chromium and iron

Let's see what advantages of nichrome are made use of in electric heating appliances.

- High resistivity
- High melting point
- Ability to remain in red hot condition for a long time without getting oxidised.

Safety fuse

Safety fuse is a device that works on the heating effect of electric current. Let's see how it works.

Fuse wire, an alloy of tin and lead, is the main part of safety fuse. Alloys are used to make fuse wire. Fuse wire has a relatively low melting point. In each circuit the fuse wire should be used in accordance with the current flowing through it.

- Which are the circumstances that cause high electric current, leading to the melting of fuse wire?

- How is the fuse wire connected to a circuit? In series/ parallel?

- You know that according to Joule's Law, more heat will be produced when electric current is increased. What happens to the fuse wire due to this?

- When heat is generated, why does the fuse wire melt?

- When the fuse wire melts, the circuit is broken. What happens to the current in the circuit?

Why is the fuse used in a circuit called safety fuse? Explain.

During the entire time of the passing of current through a circuit, a small amount of heat is generated in the fuse wire. But this heat will be transmitted to the surroundings. When the current that flows into the circuit exceeds the permissible limit, the heat generated becomes excessive. Since more heat is generated in unit time than the heat transmitted, the fuse wire melts.

Safety fuse is a device which protects us and the appliances from danger when an excess current flows through the circuit.

Is the current passing through different circuits the same? Intensity of electric current differs from one appliance to another. Hence fuse wires of appropriate amperage should be selected.

When a fuse wire is included in a household wiring, what are the precautions to be taken? Let's see.

- The ends of the fuse wire must be connected firmly at appropriate points.
- The fuse wire should not project out of the carrier base.
-

Electric power

You might have noticed the marking of 500 W on an electrical appliance. What does it indicate? An electrical appliance works by making use of electrical energy. Hence it has a power.

You have studied in the earlier class that power is the work done per unit time.

The amount of energy consumed by an electrical appliance in unit time is its power.

Power is calculated using $P = \left(\frac{W}{t} \right)$

- What is the unit of power?
- According to Joule's Law, the heat generated (H) in an electrical circuit in an interval of time t second or the work done is $H = I^2Rt$. Then, how is the power calculated?



Gauge

Gauge is the reciprocal of the diameter of a conductor. As the gauge increases, the thickness of the conductor decreases and hence the amperage also decreases.

Amperage

Amperage (A) is the ratio of the power of an equipment to the voltage applied. Amperage increases with the thickness of the conductor.

$$\text{Work done } H = I^2Rt$$

$$\text{Time} = t$$

$$\text{Power, } P = \frac{\text{Work}}{\text{time}} = \frac{H}{t}$$

$$\text{Power } P = \frac{I^2Rt}{t}$$

$$P = I^2R$$

$$\text{By Ohm's Law, } I = \frac{V}{R}$$

$$P = I^2R$$

$$= \left(\frac{V}{R}\right)^2 R = \frac{V^2}{R}$$

$$\text{Thus, } P = \frac{V^2}{R}$$

If $R = \frac{V}{I}$ what will be P ?

$$P = I^2R = I \times \dots = \dots$$

The unit of electric power is watt (W).

- An appliance of power 540 W is used in a branch circuit. If the voltage is 230 V, what is its amperage?

$$\text{Amperage} = \frac{\text{Wattage}}{\text{Voltage}} = \frac{W}{V}$$

$$I = \frac{W}{V} = \frac{540}{230} = 2.34 \text{ A} \approx 2.4 \text{ A}$$

- A heating appliance has a resistance of 115 Ω . If 2 A current flows through it, what is the power of the appliance?

$$R = 115 \Omega$$

$$I = 2 \text{ A}$$

$$\text{Power } P = I^2R$$

$$= 2^2 \times 115 = 460 \text{ W}$$

- A current of 0.4 A flows through an electric bulb working at 230 V. What is the power of the bulb?

Lighting effect of electric current

Filament lamps were in wide use in the early days. Observe the parts of a filament lamp shown in Fig 1.10.

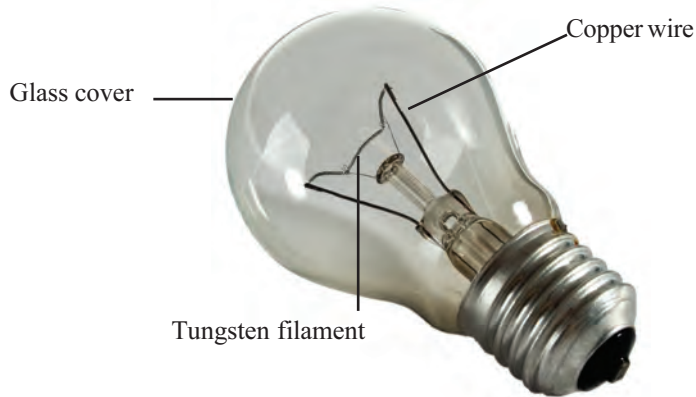


Fig 1.10



Incandescent lamps

In normal voltages, the filament becomes white hot and gives out light. Such bulbs are the incandescent (glowing with heat) lamps. Filaments made of the metal tungsten are used in them. Tungsten can become white hot and emit white light for a long time. In order to avoid oxidation of tungsten, the bulb is evacuated. Vaporisation can be reduced by filling some inert gas at low pressure inside the bulb. Nitrogen is usually used for this purpose now.

- Why is the bulb filled with an inert gas/ nitrogen?

- What properties of tungsten make it suitable for being used as a filament?

 - high resistivity
 - high melting point
 - high ductility
 - ability to emit white light in the white hot condition



Why Nitrogen?

At normal temperature and pressure, nitrogen behaves like an inert gas. Small increase in temperature does not influence the expansion of nitrogen. The ready availability of nitrogen is one of the reasons for it being used in bulbs. In the absence of air within the bulb, this gas behaves completely as an inert gas.

- Nichrome is not used as filament in incandescent lamps. Why?

- Touch a filament lamp after it has been lit for a short period of time. What do you feel?

A major part of the electrical energy supplied to an incandescent lamp is lost as heat. Hence the efficiency of these devices is less.

Haven't you understood that a major part of the electricity supplied to an incandescent lamp for obtaining light is lost as heat?

By now it may be clear to you why the use of incandescent lamps is to be restricted.

What are the other types of lamps working on electricity? List them.

- Discharge lamp
- Fluorescent lamp
-
-

Discharge lamps



Sodium vapour lamp



Arc lamp



Fluorescent lamp



CFL

Fig 1.11

Discharge lamps are glass tubes fitted with two electrodes. They emit light as a result of discharge of electricity through the gases filled in tubes. When a high potential difference is applied the gas molecules

get excited. Excited atoms come back to their original states for attaining stability. During this process the energy stored in them will be radiated as light. Depending on the difference in the energy levels lights of different colours and other radiations are emitted.

- What are the advantages of using discharge lamps instead of incandescent lamps?
 - What are the factors to be considered when you select a bulb?
- Which are the lamps that are mostly used? Why?

LED bulbs are devices that give more light than discharge lamps and incandescent lamps. They work using low power. What are their peculiarities?

LED bulb (Light emitting diode bulb)

- LEDs are Light Emitting Diodes.
- As there is no filament, there is no loss of energy in the form of heat.
- Since there is no mercury in it, it is not harmful to environment
-
-



LED Bulb
Fig 1.12



LED Bulbs

(Construction, repair, reuse and disposal)

It is the research for high energy efficient and less polluting bulbs that led to the invention of LED bulbs. LED bulbs are more efficient than other bulbs. Low power consumption, high efficiency and high longevity are the advantages. Production of LED bulbs at low cost must be encouraged to enhance their use. At the same time we should know how to do minor repairing of the bulb to facilitate

its reuse and also the scientific methods of its disposal to minimise the related environment problems.

Let's do some activities to understand about LED bulbs.

Let's familiarise with the parts of the bulb.

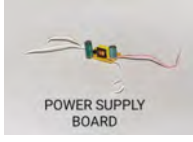


Part of on LED bulb	Use	Part of the LED bulb	Use
Base unit E22  <p>BASE UNIT</p>	This is the metallic part that connects the bulb to the holder	Power Supply board (LED driver)  <p>POWER SUPPLY BOARD</p>	Function of this is to convert AC into DC and supply necessary output voltage (The same board can be used for 5W, 7W and 9 W bulbs.)
Heat sink 	The part close to the base unit of the bulb. It is an arrangement for absorbing heat from the base.	Printed Circuit Board (LED Chip Board)  <p>PRINTED CIRCUIT BOARD</p>	LEDs are fixed on this board. In this the positive and negative polarities are marked.
Base plate 	Metal plate that fixes it to the holder.	Diffuser cup  <p>DIFFUSER</p>	This is the part from which light comes out of the bulb.
Back conductor Screws. 	Screws for fixing wires from LED drive to the base unit.		

Figure Showing a Completed LED Bulb Circuit



Other accessory tools required to construct an LED bulb



Insulation tape

Pliers

Heat sink compound

Wire stripper

Soldering iron

Solder Lead

Soldering wax

Construction

- Fix the base unit by punching it on to the heat sink
- Cover the power supply board using insulation tapes in such a way that the input and output supply wires will be visible out but will not get covered with dust or moisture.
- Fix the wires seen on the input part of the power supply board to the back conductor, by passing it through heat sink and terminal holes.
- Fix the red wire in the output into the part marked positive in the board and the black wire into the negative marking.
- Apply heat sink compound at the back of the LED Printed Circuit Board and then fix it on the base plate.
- Press and close the heat sink by using the diffuser cup.

Make sure that the LED bulb thus made emits light when fixed to the bulb holder.

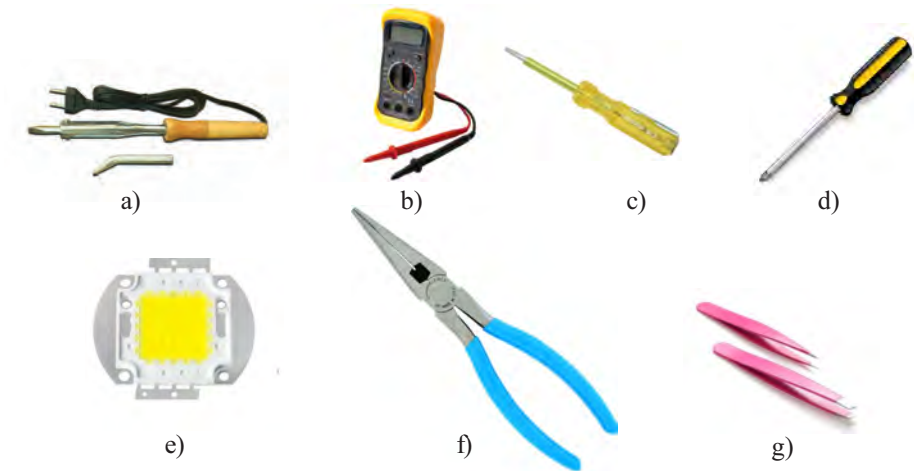
Repairing the damages in the LED bulbs

- An LED bulb is a combination of many LEDs connected in series. The bulb will fail to emit light if any one LED is damaged or if the contact of any one LED is lost.
- LED bulb will not emit light if the rectifier or load resistor or filter capacitor is damaged.
- Even a minor damage in an LED bulb will lead to complete failure in the working of the bulb. How can these errors be rectified?

The Main Components of an LED bulb

Examine a damaged LED bulb and find out the following parts
(*Rectifier, Load resistor, Filter capacitor, LED Chip, Heat Sink*)

Let's familiarize with the tools required to repair LED bulbs.



- | | |
|-------------------|-----------------|
| a) Soldering iron | b) Multimeter |
| c) Tester | d) Screw driver |
| e) LED Chip | f) Nose pliers |
| g) Tweezer | • |

Open a non functioning bulb and examine each part using a multimeter to know whether the parts are functioning or not.

Find out which of the following parts are damaged in an LED bulb and replace them with new ones.

- Rectifier
- Load resistor
- Filter capacitor
- LED Chip

How can the LED bulbs be disposed of scientifically?

- Segregate the plastic, electronic and metal components of LED bulb and transfer them to their respective disposal units.
- Don't you have to enhance the use of LED bulbs which are environment friendly and suitable for energy conservation?

*Energy saved is equivalent
to energy produced*



Let us assess

- Fuse wire is to be used by understanding the amperage correctly. Write down the amperage of the fuse wires that are currently available in the market.
- 0.5 A current flows through an electric heating device connected to 230 V supply.
 - the quantity of charge that flows through the circuit in 5 minute is
(i) 5 C (ii) 15 C (iii) 150 C (iv) 1500 C
 - How much is the resistance of the circuit?
 - Calculate the quantity of heat generated when current flows in the circuit for 5 minute.
 - How much is the power of the heating device connected to the circuit if we ignore the resistance of the circuit wire?
- According to Joule's Law the heat generated due to the flow of current is $H = I^2Rt$. Will the heat developed increase on increasing the resistance without changing the voltage? Explain.
- The table shows details of an electric heating device designed to work in 230 V. Complete the table by calculating the change in the heat and power on changing the voltage and resistance of the device. Analyse the table and answer the following questions.

Operating voltage	Resistance of the device (R)	Current flowing in the device $I = V/R$	Heat generated per second Heat, $H = V \times I \times t$	Power given by the device $P = V \times I$ or $P = H/t$	Reason for the change in power
230 V	57.5 Ω	4A	920 J	920 W	
230 V	115 Ω	-----	-----	-----	
230 V	230 Ω	-----	-----	-----	
115 V	57.5 Ω	-----	-----	-----	
460 V	57.5 Ω	-----	-----	-----	

- How does the voltage under which a device works affect its functioning?

- (b) What change happens to power on increasing the resistance without changing the voltage?
- (c) What change is to be brought about in the construction of household heating devices in order to increase their power?
5. (a) Complete the table based on the amperage of the fuse wire.

Electrical device	Operating voltage (V)	Power of the device (P)	Current through the circuit $I = P/V$	The amperage of the fuse to be used in the circuit (A)
Water heater	230 V	4370 W	19 A	20 A
Air conditioner(AC)	230 V	-----	14.5 A	-----
Television (LED - TV)	230 V	57.5 W	-----	-----
Computer (Laptop)	230 V	-----	0.125 A	-----

- b) The amperage of the fuse wire used in a circuit that works on 230 V is 2.2 A. If so the power of the device is
- less than 300 W
 - 300 W to 500 W
 - between 500 W and 510 W
 - more than 510 W
6. A 230 V, 115 W filament lamp works in a circuit for 10 minute.
- What is the current flowing through the bulb?
 - How much is the quantity of charge that flows through the bulb in 10 minute?
7. An electric heater conducts 4 A current when 60 V is applied across its terminals. What will be the current if the potential difference is 120 V?
8. Three resistors of $2\ \Omega$, $3\ \Omega$ and $6\ \Omega$ are given in the class.
- What is the highest resistance that you can get using all of them?
 - What is the least resistance that you can get using all of them?
 - Can you make a resistance $4.5\ \Omega$ using these three? Draw the circuit.

9. A girl has many resistors of $2\ \Omega$ each. She needs a circuit of $9\ \Omega$ resistance. For this draw a circuit with the minimum number of resistors.
- 10.



If a bulb is lit after rejoining the parts of a broken filament, what change will occur in the intensity of the light from the lamp? What will be the change in the power of the bulb?

11. Which of the following does not indicate the power of a circuit?
 (a) I^2R (b) VI (c) IR^2 (d) V^2/R
12. How much will be the power of a 220 V, 100 W electric bulb working at 110 V?
 (a) 100 W (b) 75 W (c) 50 W (d) 25 W
13. Which of the following should be connected in parallel to a device in a circuit?
 (a) voltmeter (b) ammeter (c) galvanometer
14. When a 12 V battery is connected to resistor, 2.5 mA current flows through the circuit. If so what is the resistance of the resistor?
15. If $0.2\ \Omega$, $0.3\ \Omega$, $0.4\ \Omega$, $0.5\ \Omega$ and $12\ \Omega$ resistors are connected to a 9 V battery in parallel, what will be the current through the $12\ \Omega$ resistor?
16. How many resistors of $176\ \Omega$ should be connected in parallel to get 5A current from 220 V supply?
 a) 2 b) 3 c) 6 d) 4
17. Depict a figure showing the arrangement of three resistors in a circuit to get an effective resistance of (i) $9\ \Omega$ (ii) $4\ \Omega$



Extended activities

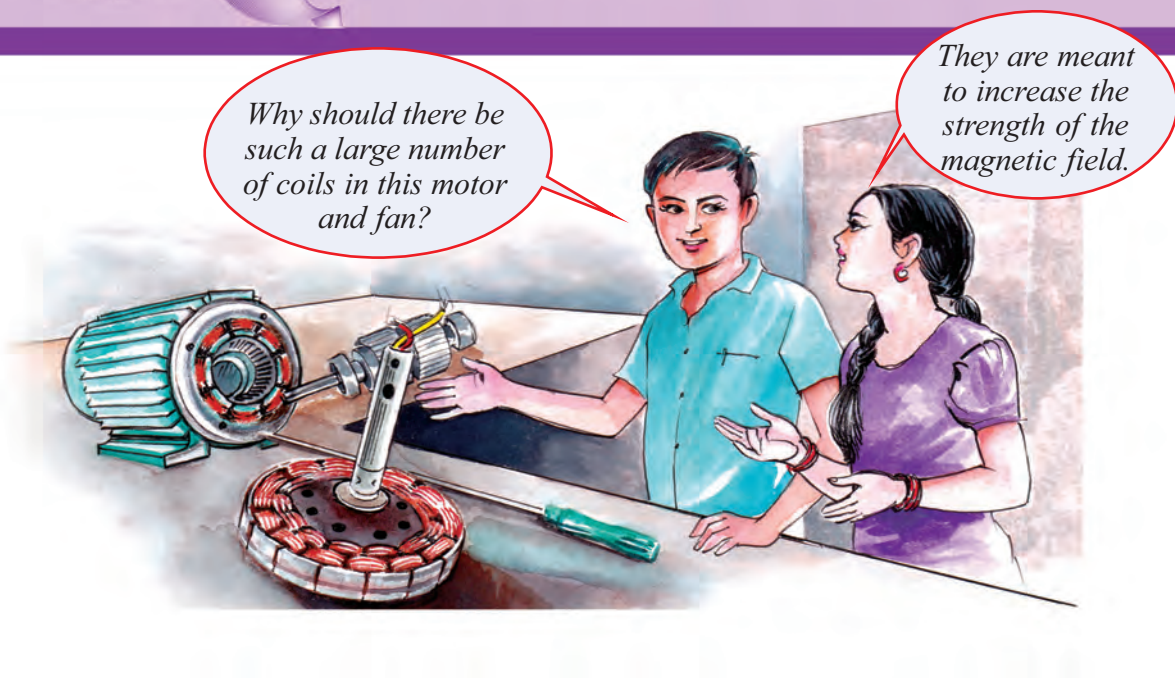
- Analyse and describe the working of a microwave oven.
- How does an arc lamp help in rescue operations?
- With the help of teachers and the Internet find out the following

- (a) What is the percentage of nickel, chromium and iron in Nichrome?
 - (b) How much is the melting point of nichrome in degree celsius?
 - (c) How much is the resistivity of Nichrome?
 - (d) Does the result of your observation justify the use of nichrome as a heating element ?
4. Analyse the merits and demerits of the following lamps and find out which is best in the group. Justify your answers.
- (a) filament lamp
 - (b) fluorescent lamp
 - (c) arc lamp
 - (d) CFL
 - (e) LED bulb



2

Magnetic Effect of Electric Current



How do the coils strengthen the magnetic field?

Let's do some activities to understand it better.

Observe the depiction of magnetic fields of two types of magnets.

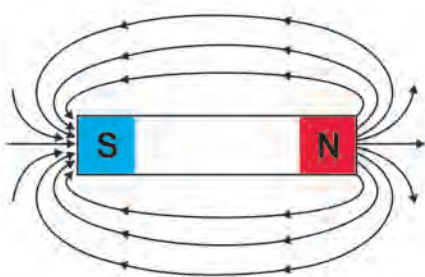
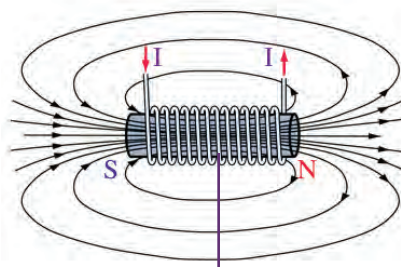


Fig. 2.1



Soft iron core
Fig. 2.2

- The magnetic field of which magnets are depicted?
- How can you identify the direction of the magnetic fields?



Hans Christian Oersted (1777-1851)



Oersted was a famous scientist who conducted many experiments in the field of magnetic effect of electric current. In the year 1820 he accidentally noticed that a magnetic needle kept near a current carrying conductor experienced deflection. Thus the unbreakable relation between electricity and magnetism was realised for the first time. His experiments marked the beginning of the technology behind the devices used today like radio, TV and fibre optics. As a mark of respect to him, the CGS unit of intensity of magnetic field has been named as oersted.

- How can you find out the polarity of these magnets using a magnetic compass?
- What are the main differences between the magnets in the picture?

The magnetic field lines of the bar magnet and that of the electromagnets are similar. The presence of the magnetic field and the polarity can be understood using a magnetic compass. The magnetic strength/magnetism of an electromagnet is temporary.

The magnetic field around an electromagnet is created due to the flow of current through the coils in it. By this we can assume that a magnetic field will be developed when current passes through a straight conductor. Let's try to do a similar experiment that led Oersted to this conclusion.

Arrange a circuit above a pivoted magnetic needle in such a way that the part AB of the conductor is parallel and close to the magnetic needle, as shown in Fig 2.3 (a).

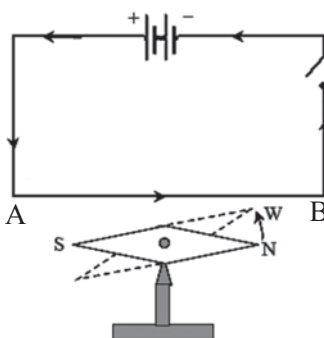


Fig. 2.3 (a)

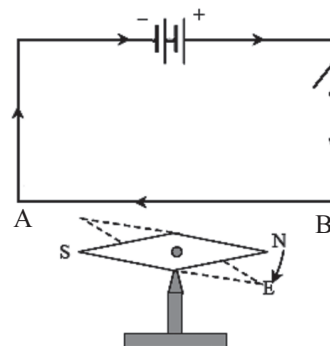


Fig. 2.3 (b)



Switch on the circuit.

- Observe the direction in which the North Pole(N) of the magnetic needle deflects and complete the Table 2.1.

When the direction of electric current is from A to B, what will be the direction of the electron flow through it?

Repeat the experiment after reversing the current and record your observations in the table.

No.	Conductor above the magnetic needle	Direction of motion of North Pole (N) of the magnetic needle clockwise/anticlockwise
1	Direction of current from A to B
2	Direction of current from B to A

Table 2.1

Repeat the experiment keeping the conductor below the magnetic needle and record the observations in the table.

No.	Conductor below the magnetic needle	Direction of motion of North Pole (N) of the magnetic needle clockwise/anticlockwise
1	Direction of current from A to B
2	Direction of current from B to A

Table 2.2

Find out the answer for the following based on the experiment.

- What might be the reason for the deflection of the magnetic needle?
- Does the deflection depend on the direction of current?

We have already studied that a magnetic field exerts force on magnets. In this case, the magnetic field must have produced the force required to move the magnetic needle. How is this magnetic field produced? Think it over.

A magnetic field is developed around a current carrying conductor. The magnetic needle is deflected as a result of the mutual action of this magnetic field and that around the magnetic needle.

From this, it is understood that a magnetic field is developed around a current carrying conductor. Let's examine the speciality of this magnetic field through an experiment.

Insert a conductor through a cardboard and keep it in a vertical position as

shown in the figure. The portions passing through the cardboard are marked as X and Y.

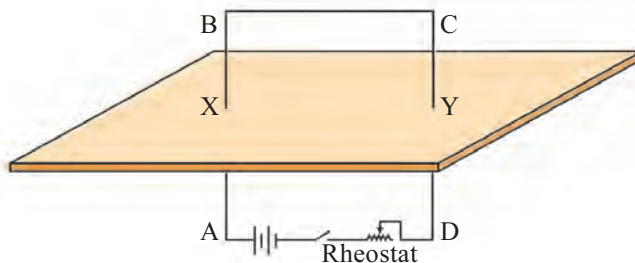


Fig. 2.4



Using a magnetic compass, draw the direction of the magnetic field around the point X when current passes through the conductor. Then complete the given work sheet.

- Is the direction of current in the circuit between A and B from A to B or from B to A?
- Examine whether the direction of magnetic field lines around X are in the clockwise or anticlockwise direction by observing the North Pole of the magnetic compass.

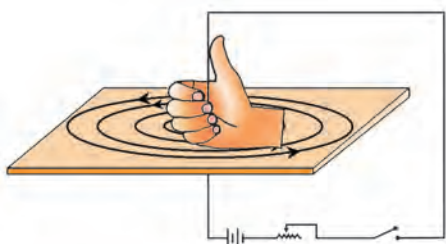


Fig. 2.5

- Hold the portion of the conductor near X using the right hand (as in Fig. 2.5) in such a way that the thumb is in the direction of the current (positive to negative).
- Compare the directions of the fingers of the right hand encircling the conductor and the magnetic field lines.

Compare the directions of fingers, current and that of the magnetic field and write down the inference in the science diary.

*What we have understood is the **Right Hand Thumb Rule** of James Clark Maxwell. Imagine you are holding a current carrying conductor with the right hand in such a way, that the thumb points in the direction of the current. The direction in which the other fingers encircle the conductor gives the direction of the magnetic field.*

The same rule is also known as Right Hand Screw Rule. If a right hand screw is rotated in such a way that its tip advances along the direction of the current in the conductor, then the direction of rotation of the screw gives the direction of the magnetic field around the conductor.

Will you be able to make the conductor, passing through the cardboard, in the shape of a coil as shown in the figure? Examine the direction of magnetic field at C using a magnetic compass and mark it on the cardboard. Draw an inference based on the discussion indicators given.

- Are the magnetic field lines inside the coil seen in the same direction?
- What is the difference observed in the direction of magnetic field lines on reversing the current through the solenoid?

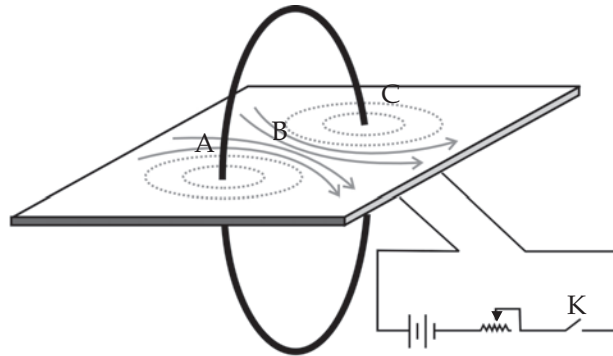


Fig. 2.6

When the coil is viewed in such a way that the current is in the clockwise direction, how are the magnetic fields marked?

Into the coil/ out from the coil.

How will the magnetic field lines appear when the coil is viewed in such a way that the current is in the anticlockwise direction?

When the electric current passes in the clockwise direction, the magnetic field lines appear to move away from us into the coil through the central part of the coil. But if the electric current passes in the anticlockwise direction, the magnetic field lines appear to move out towards us from the coil through its centre.

Let's see how the number of turns of the coiled conductor and the intensity of current affect the magnetic field. Keep a current carrying circular conductor vertically in the North South direction (Fig.2.7). The magnetic field produced as a result will be in the East West direction. Draw a perpendicular bisector to the line joining the points A and B. This line passes through the centre of the coil. Move the compass along this line in both directions away from the centre. When the magnetic effect of the coil vanishes, the magnetic needle will come to rest in the North South direction.

Measure the distance between these points on either side of the coil. Perform this experiment by increasing the number of turns of the coil and see how far the magnetic needle remains in the East West

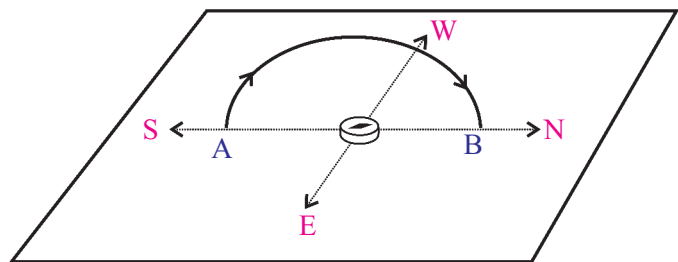


Fig. 2.7

direction on either side. Now the distance between the two points increases. Is it not due to the increase in the strength of the magnetic field? (It has to be ensured that the electric current is the same in both the experiments).

Repeat the experiment changing the current using a rheostat.

The strength of the magnetic field increases when the number of turns of the coil or current is increased.

Record in the science diary the various factors affecting the magnetic effect of electricity.

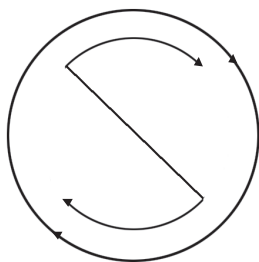


Solenoid

A solenoid is an insulated wire wound in the shape of a helix. Such coiled conductors are used to make use of the magnetic effect of electricity. Let's examine how we can recognise the direction of magnetic field and the polarity of a current carrying solenoid.

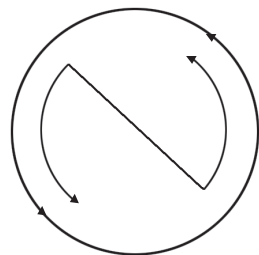


Fig. 2.8 (a)



Current in the clockwise direction

Fig. 2.8 (b)



Current in the anti clockwise direction

Fig. 2.8 (c)

Take an insulated copper wire of length not less than 1 m and make a solenoid (preferably a wire of gauge number 26)

- Count the number of turns in it.
- It will act as a magnet when current from a cell is passed through it after inserting a soft iron core. What is this device known as?
- With the help of a magnetic compass check the speciality of the magnetism at either ends of the solenoid.
- What is the change observed in the movement of the magnetic needle when the experiment is repeated after removing the soft iron core?
- From the movements of the magnetic needle in the magnetic compass, find out the polarity of the solenoid and mark them.
- Hold a current carrying solenoid with one end facing you. Note the direction of current at that end. Is it clockwise or anticlockwise?
- Find out the relationship between the direction of current and the polarity.

The end of the solenoid at which current flows in the clockwise direction will be the South Pole and the end at which current flows in the anticlockwise direction will be the North Pole.

Based on the above activities, tabulate the factors affecting the strength of the magnetic field of a solenoid carrying current.

- Intensity of electric current •
- •

Depicted below are the lines of force formed around a solenoid carrying current and a bar magnet.



Fig. 2.9

Both are identical. Analyse and compare the ability of solenoid and bar magnet to bring changes in permanency of the magnetism, polarity and the strength of the magnetism.

Bar magnet	Solenoid
<p>The magnetism is permanent</p> <p>.....</p> <p>.....</p>	<p>The magnetism is temporary</p> <p>.....</p> <p>.....</p>

Table 2.3

Use of magnetic effect of electricity

We had seen fan, motor, etc. at the beginning of the chapter. Aren't they used to produce motion? Let's examine how the magnetic effect of electricity is made use of in them.

The figure shows a copper wire suspended between the pole pieces of a U shaped magnet, using thin conductors in such a way that the wire is perpendicular to the magnetic field and it is free to oscillate in the magnetic field.

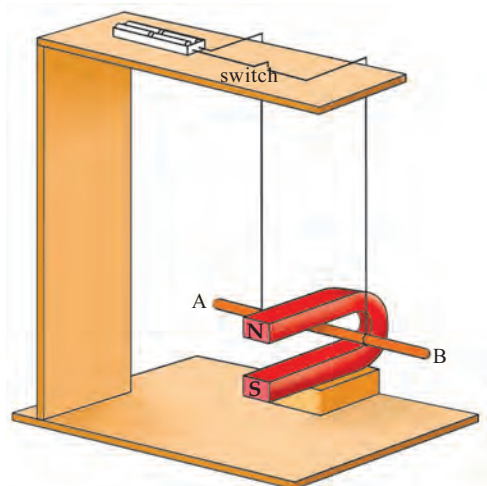


Fig. 2.10

Does the conductor move when the circuit is switched on? Observe in which direction it is moving.

Repeat the experiment by changing the direction of current.

Repeat the experiment by interchanging the position of the magnetic poles.

What are the factors that influence the direction of motion of the conductor?

- Direction of current
- Direction of magnetic field

Aren't the direction of the magnetic field and the direction of current mutually perpendicular in this arrangement?

Hold the forefinger, middle finger and the thumb of the left hand in mutually perpendicular direction.

Hold the forefinger in the direction of the magnetic field and middle finger in the direction of current. Isn't the conductor moving in the direction indicated by the thumb?

Repeat the experiment by changing the direction of current and magnetic field. You might have understood that the direction of current and that of the magnetic field are mutually perpendicular. Fleming established a rule that will help to find out the direction of motion of the conductor in the devices making use of magnetic effect of electricity.

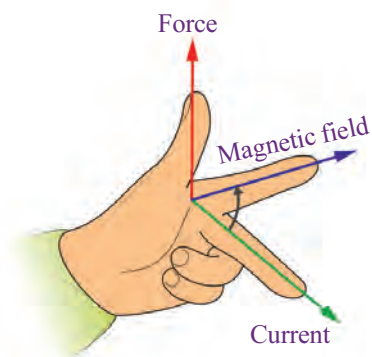


Fig. 2.11



Fleming's Left Hand Rule

Hold the forefinger, the middle finger and the thumb of the left hand in mutually perpendicular directions as shown in the figure. If the forefinger indicates the direction of the magnetic field and the middle finger, the direction of the current, then the thumb will indicate the direction of motion of the conductor.

Motor principle

A conductor, which can move freely and which is kept in a magnetic field, experiences a force when current passes through it and it moves.

The working of electric motor is based on this principle. The motor principle is also used in devices like fan, mixer etc.

Electric Motor

Note the parts of an electric motor shown in the figure.

- N,S - Magnetic poles
- XY - Axis of rotation of the motor
- ABCD - Armature
- B₁, B₂ - Graphite brushes
- R₁, R₂ - Split rings

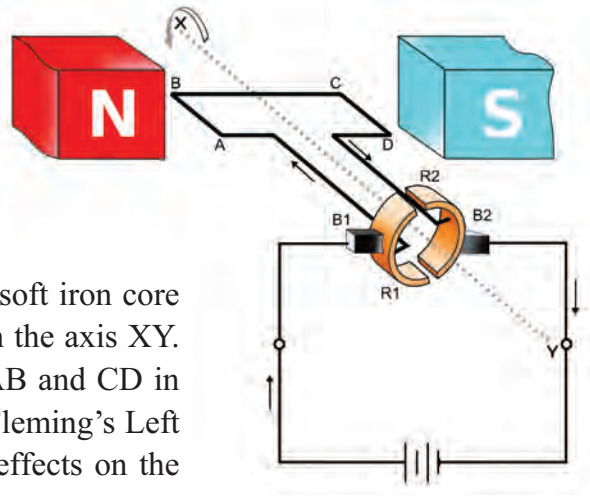


Fig. 2.12

Armature

Armature is the metallic coil wound round a soft iron core so that it is free to rotate. It is fixed firmly on the axis XY. In the figure, are the forces acting on sides AB and CD in the same direction? Find out on the basis of Fleming's Left Hand Rule and write it down. What are the effects on the armature produced by forces thus developed?

Split ring Commutator

If the rotation of the armature is to be sustained the direction of current through the armature should continuously keep on changing. The split rings help to change the direction of current through the coil after every half rotation. Hence it is also called split ring commutator.

Moving coil loud speaker is a device that works on the basis of motor principle

Moving coil loud speaker

Observe the picture showing the structure of a loud speaker.

- Where is the voice coil situated?

- To which part is the diaphragm connected?

- From where does the electric current reach the voice coil?

- What happens when current is passed through the voice coil?

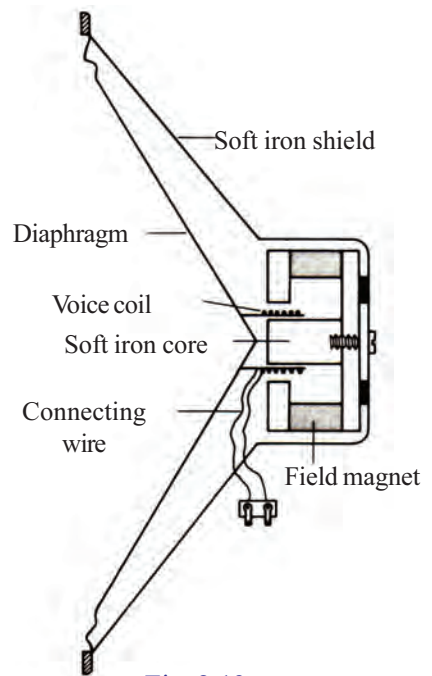


Fig. 2.13

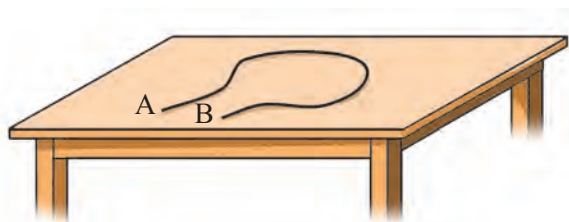
The electrical pulses from a microphone are strengthened using an amplifier and sent through the voice coil of a loudspeaker. The voice coil, which is placed in the magnetic field, moves to and fro rapidly, in accordance with the electrical pulses. These movements make the diaphragm vibrate, thereby reproducing sound.

Now you have understood the relation between electricity and magnetism. Can magnetic power be used for the production of electricity? You will learn more about this in the following unit.



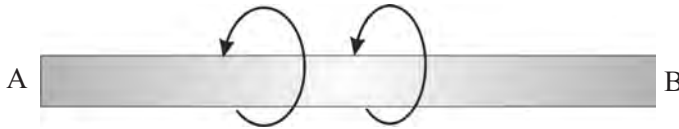
Let us assess

1. Current is passed from South to North through a conductor placed below a freely pivoted magnetic needle.
 - a) To which direction will the North Pole of the magnetic needle turn?
 - b) Which is the rule used to arrive at this inference?
 - c) State the rule.
 - d) If the current flows in the conductor in the East West direction, what do you guess about the deflection of the magnetic needle? Explain.
2. How will you determine the polarity when current is passed through a solenoid? Suggest methods for increasing the strength of the magnetic field around a current carrying solenoid.
3. The figure shows an insulated copper wire AB made into a coil. Suppose current flows from A to B through this.



- a) What will be the direction of electron flow through it?
- b) Can you find out the direction of the magnetic field around the conductor AB? State the rule that substantiates this.
- c) Explain how you can find out the direction of the magnetic field inside the coil.

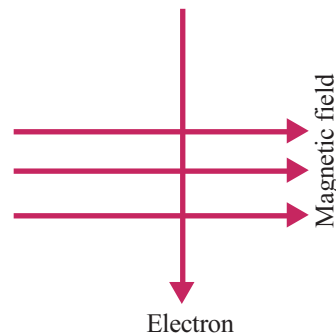
4. The magnetic field around the current carrying conductor AB is depicted.



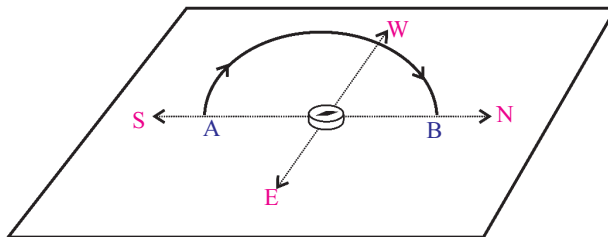
Based on the Maxwell's Right Hand Cork Screw Rule find out the direction of current and record it.

5. Electricity flows through a very long solenoid. Some statements are given below related to the magnitude of the magnetic field developed. Find out the correct ones and write them down.
- It is zero
 - It will be the same at all points
 - It gradually decreases towards the ends.
 - It gradually increases towards the ends.
6. The direction of movement of electrons through a magnetic field is depicted.

“The force felt by the electrons due to the influence of the magnetic field is into the plane of the paper”. Is this statement correct? Explain based on the Fleming's Left Hand Rule.



7. In an experiment to know the intensity of magnetic field around a current carrying coil, why is the coil kept in the North South Direction.



8. In the split ring commutator of a DC motor, semi circular rings are used. What is the need for this?
9. A current carrying solenoid is stretched to increase the distance between the coils. What change will occur in its magnetic field? Describe.

10. State the Motor Rule. If the directions of current in the conductor and the magnetic field are the same, in which way will the conductor move?



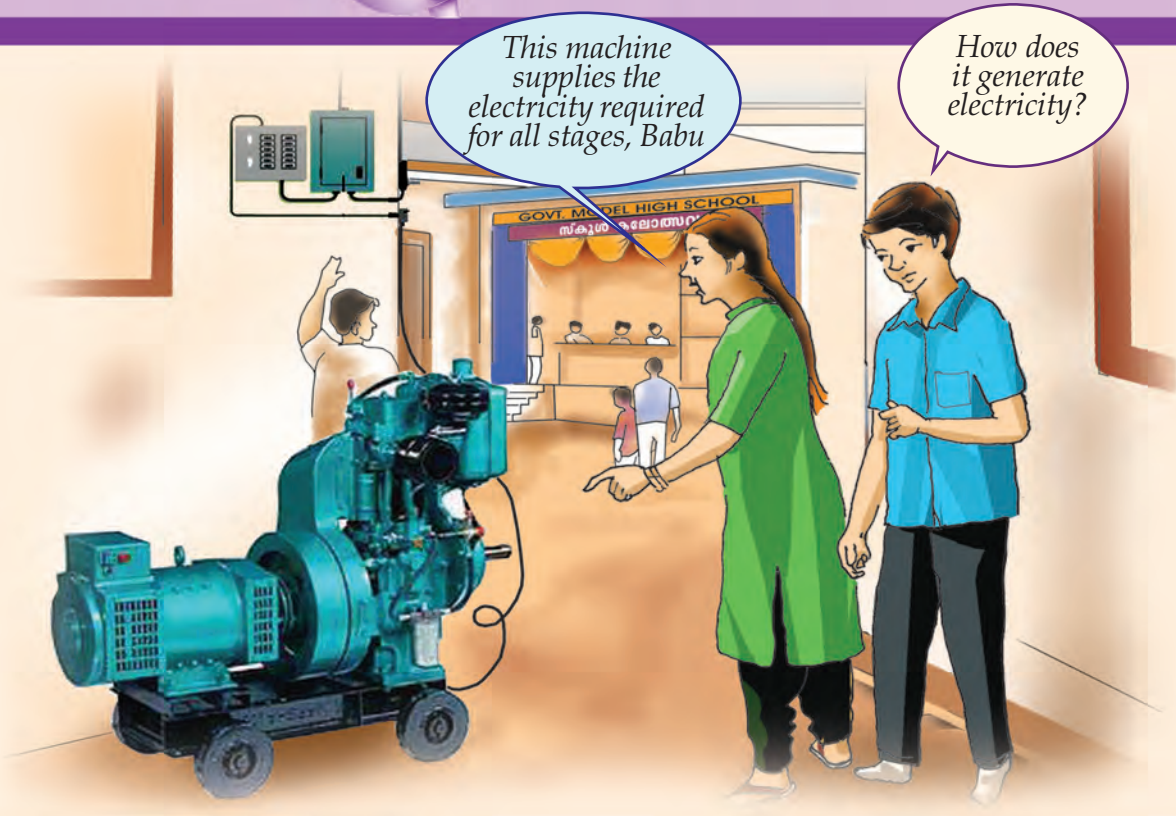
Extended activities

1. Observe the defunct electrical devices in your home, examine them and familiarize the parts.
2. Construct a simple DC motor using copper wire, cell and permanent magnet. Compare the parts of it with that in the diagram given in the textbook.
3. Dismantle the parts of a loudspeaker that is defunct and arrange them on a sheet of paper one by one and exhibit. What is the reason for its voice coil being very thin?



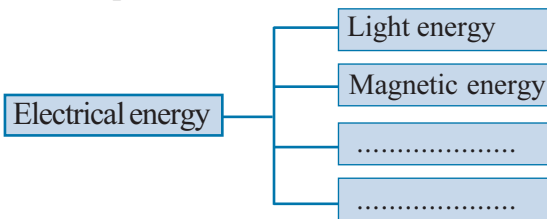
3

Electromagnetic Induction



Can you clear Babu's doubt?

You know that electrical energy can be converted into many other forms. Write down some examples.



You know that a solar cell converts solar energy into electrical energy. Like this which are the other forms of energy that can be converted into electrical energy? Let's see whether we can convert magnetic energy into electrical energy.

You have understood from the previous chapter that a conductor in a magnetic field experiences a force. As a result the conductor moves. If it's so, will electricity be generated when a conductor is moved in a magnetic field?

It was Michael Faraday who presented such an experiment for the first time. Let's do this experiment.

Materials required

- Bar magnet
- Solenoid
- Galvanometer

Arrange the above materials as shown in the figure. Insert the magnet into the solenoid and pull it out successively. Observe the deflection of the needle of the galvanometer each time.

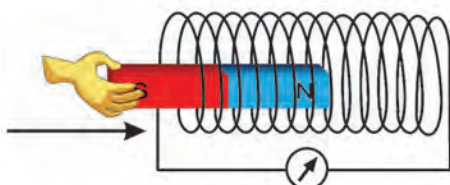


Fig 3.1 (a)

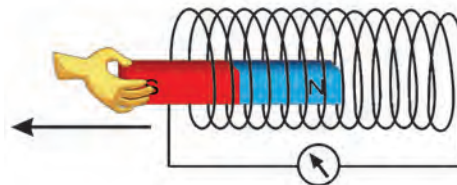


Fig 3.1 (b)

Record your observations in the table given below.

Sl. No.	Experimental procedure	Observation (Galvanometer needle)	
		Deflects/ does not deflect	Direction to the left/ to the right
1	The magnet is stationary near the solenoid		
2	North pole of the magnet is moved into the solenoid		
3	The magnet is stationary inside the solenoid		
4	The magnet is moved out of the solenoid.		
5	The south pole of the magnet is moved into the solenoid		
6	Magnet and solenoid are moved in the same direction at the same speed		
7	The solenoid is moved keeping the magnet stationary		

Table 3.1

Repeat the experiment using magnets of greater strength, and increasing the number of turns in the solenoid. On the basis of the experiment, complete the Table 3.2.

Experiment	Deflection of the galvanometer needle	
	increases	decreases
Number of turns increased		
Strong magnet is used		
Magnet/solenoid moves with greater speed.		

Table 3.2

On the basis of the above experiment and analysis of the table, find out the answers to following questions and write them down in the science diary.

- Why did the galvanometer needle deflect in the experiment?
- Which were the instances in which there was a flow of current through the solenoid?
- Which were the instances in which the current increased?

Electromagnetic Induction

Whenever there is a relative motion between the magnet and the solenoid, there is flow of electricity. We have understood this from the experiment. But have you ever thought about what happens when the magnet is brought near or moved away from the solenoid?

Observe the figure given below.

(The figure indicates the two stages of doing the experiment)

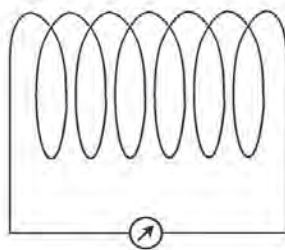
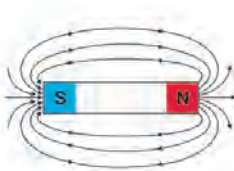


Fig 3.2 (a)

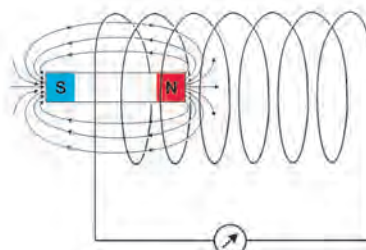


Fig 3.2 (b)



Galvanometer

Galvanometer is a device used to understand the direction and magnitude of even a small current. In the normal position the needle rests at zero. The needle will deflect to the right or left depending on the direction of current. The deflection increases with the increase in current.

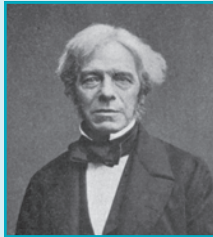


symbol

- On which instance will the magnetic flux linked with the solenoid be less?
- On which instance will the magnetic flux linked with the solenoid be greater?
- On which instance does a change in magnetic flux linked with the solenoid occur? (while it is moving/ while it is stationary)



Michael Faraday



(1791-1867)

Faraday, an illustrious scientist in the fields of Physics and Chemistry, made his first invention in 1821. He showed that a current carrying conductor, kept in a magnetic field, can move. As a result of a series of experiments conducted by him in 1831, he could generate electricity from a magnetic field. He is known as the Father of electricity. He made valuable contributions to chemistry also. But Faraday was not fortunate enough to get formal education.

Haven't you understood that electricity is induced in a solenoid whenever there is a change in the magnetic flux linked with the solenoid? This phenomenon is known as electromagnetic induction. The current thus induced is the induced current. The voltage induced is the induced **emf**.

What may be the factors affecting the induced emf?

- Number of turns of the coiled conductor
-
-

Whenever there is a change in the magnetic flux linked with a coil, an emf is induced in the coil. This phenomenon is electro-magnetic induction.

Which are the factors on which the direction of induced current in electromagnetic induction depend?

- Direction of magnetic field
-

(The direction of magnetic field is assumed to be from the North Pole to the South Pole.)

The British Scientist John Ambrose Fleming discovered that the induced emf would be maximum if the conductor is moved perpendicular to the magnetic field lines. He also said that the relation between the direction of magnetic field, the direction of movement of the conductor and the direction of induced current could be explained in a simple way. This is known as Fleming's Right Hand Rule

Fleming's right hand rule

Imagine a conductor moving perpendicular to a magnetic field. Stretch the forefinger, middle finger and the thumb of the right hand in mutually perpendicular directions. If the fore finger represents the direction of the magnetic field, and the thumb represents the direction of motion of the conductor, then, the middle finger represents the direction of the induced current.

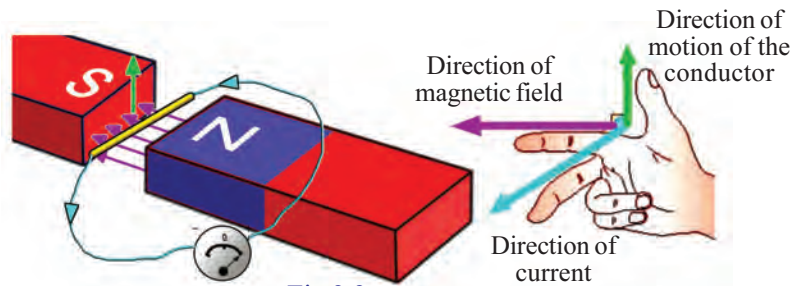


Fig 3.3

Let's see whether the current induced in a conductor from a magnetic field is the same as the current obtained from a battery/cell.

Alternating Current (AC), Direct Current (DC)

A cell that can be used in a torch or a clock is connected in series with a resistor ($6\text{ k}\Omega$) and a galvanometer. Note the direction of deflection of the needle of the galvanometer. Tabulate your observations. Then compare it with the observations in activity 2.

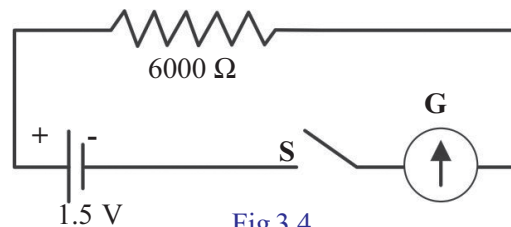


Fig 3.4

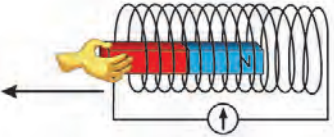
Activity	Movement of Galvanometer needle
<p>Activity 1</p> <p>The galvanometer, cell, resistor, and switch are connected in series. Circuit is switched on.</p>	
<p>Activity 2</p> <p>The galvanometer is connected to a solenoid. A magnet is moved in and out continuously in the solenoid.</p> 	

Table 3.3

The current obtained from the cell is unidirectional and is of the same magnitude. But what are the peculiarities of the current obtained by electromagnetic induction?

- Direction changes
-

A current that flows only in one direction continuously is a direct current (DC). Current that changes direction at regular intervals of time, is an alternating current (AC).

Is there any device that produces electricity continuously by the movement of a magnet or coiled conductor? It is such a device that you saw at the beginning of the chapter. Its name is generator. The cycle dynamo is also one such device.

We use mechanical energy in generators to move the magnet or coiled conductor continuously. In that case what shall be the energy change in a generator?

Mechanical energy →

Generator is a device that converts mechanical energy into electrical energy by making use of electromagnetic induction.



Generator

The following figure will help you to understand the structure of a generator.

Observe Fig 3.5(a) and write down the parts given in Fig. 3.5(b).

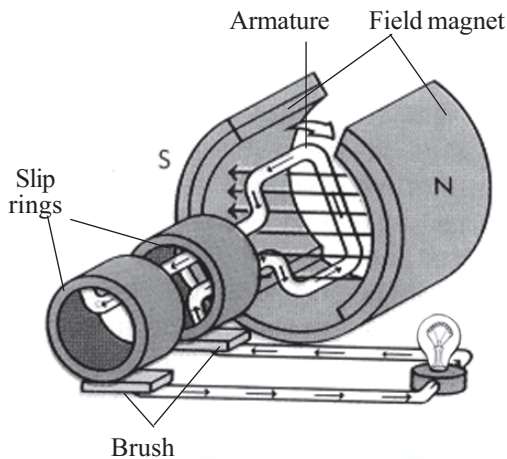


Fig. 3.5 (a)

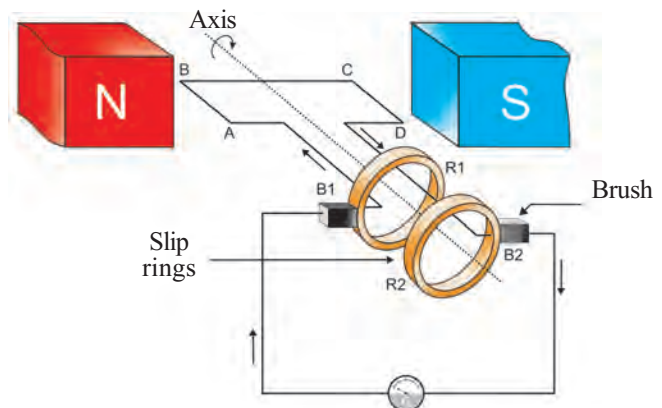


Fig. 3.5 (b)

ABCD

B_1, B_2

R_1, R_2

Observe figure 3.5(b). ABCD indicates one turn of the armature coil. When the coil rotates about the axis in the clockwise direction, the portion AB moves upward and the portion CD moves downward.

Then according to the Fleming's Right Hand Rule

- What is the direction of induced current in the portion AB? (from A to B/ from B to A)
- What is the direction of induced current in the portion CD? (from C to D/ from D to C)
- What is the direction of induced current in the coil ABCD? (from A to D/ from D to A)
- What is the direction of induced current in the external circuit? (through the galvanometer) (from B_2 to B_1 / from B_1 to B_2)

At this time, the parts of the armature AB and CD will be moving in a direction perpendicular to the direction of magnetic field. Hence the flow of electricity will be maximum. When the armature turns by 90° , the movement of the parts AB and CD are parallel to the direction of magnetic field. Hence the induced current will be zero.

What will be the positions of AB and CD when the armature completes 180° or one half rotation?

Depict this stage of rotation of the armature in the science diary. At this instance,

- What is the direction of movement of AB?
- What is the direction of movement of CD?
- What is the direction of current in the armature?
- What is the direction of current through the external circuit (through the galvanometer)?

You would have now understood that the direction of current reverses during every half rotation of the armature and that the magnitude of current is increasing and decreasing.

Parts of AC generator

Field magnet

The magnet that creates magnetic flux in the generator

Armature

An arrangement of insulated conducting wire wound on a soft iron core. This can be made to rotate about an axis.

Slip rings

Metal rings which are welded together with the armature coil. They rotate along with the armature on the same axis of rotation as the armature

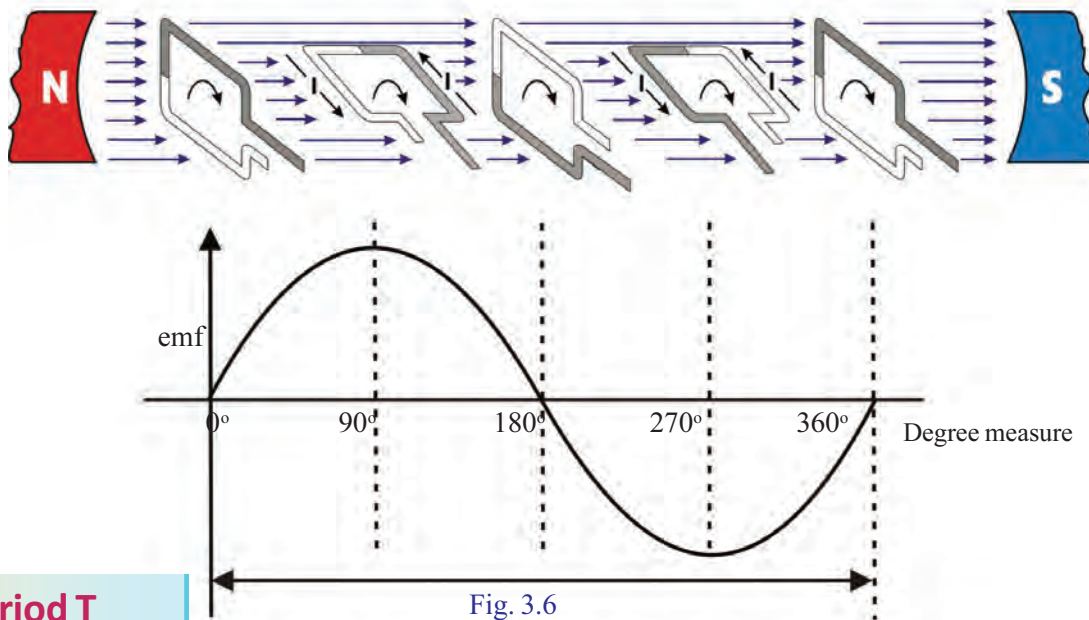
Brushes

They are arrangements which always make contact with the slip rings. Current flows through them to the external circuits.

Such a generator which generates Alternating current is an AC generator.

The various stages of rotation of an armature coil while completing one rotation in a magnetic field and the graph of the emf produced by the coil are shown in Figure 3.6.

Analyse the graph and complete the table.



Period T

The time taken by the armature coil for a full rotation is called the period, T. Time taken for half rotation (180°) is T/2.

	Time				
	0	T/4	T/2	¾ T	T
Angle of rotation of the armature.	0°	90°	180°	270°	360°
Rate of change of flux.	0	maximum	0
Induced emf in volts V.	0	maximum	0

Table 3.4

In an AC generator, the induced emf generated in the first half rotation in one direction and that generated in the second half rotation in the opposite direction together form the cycle of AC. The number of cycles per second is the frequency of AC.

The frequency of AC generated for distribution in our country is 50 cycles per second or 50 Hz.

- If the frequency of AC is to be 50 Hz, the armature coil is to rotate fifty times per second, isn't it?

In order to overcome practical difficulties, the number of rotations is reduced by increasing the number of armature coils and the number of pole pieces of the field magnet in a generator.

When 50 Hz AC is used, how many times will the direction of current change in the circuit?

Current is induced when the armature of a generator rotates. Slip rings and brushes are the ways and means by which this current is brought to the outer circuit. Is this arrangement necessary if the magnet in generator is made to rotate.

Since the rubbing of slip rings on brushes produce sparks it is the magnet that is made to rotate in AC generators. We employ several methods to generate mechanical energy required for such rotation. Generators are operated using diesel/petrol engines and water in dams.

Record in your science diary, the other ways by which mechanical energy can be made available for the working of a generator.

Now write down in your science diary how the power for operating the generator which Babu saw near the stage was generated.

Is it possible to produce DC (Direct Current) using a generator?

If split ring commutator is used in a generator instead of slip rings, we will get DC. Observe the figure.

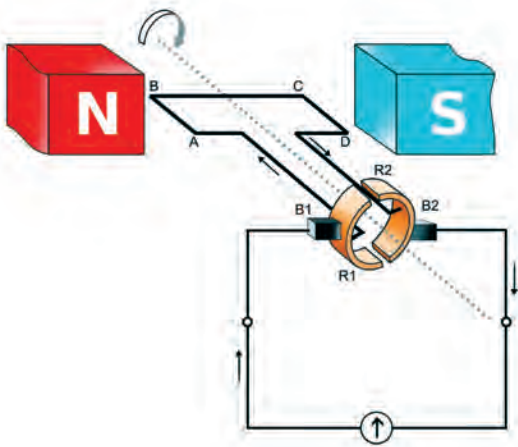


Fig. 3.7 (a)

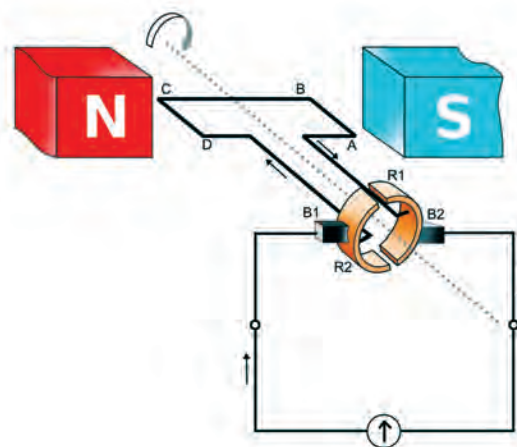


Fig. 3.7 (b)

Here a brush (B_1) is always in contact with the portion of the armature that moves upward and a second brush (B_2) is always in

contact with the portion of the armature that moves downward. As a result we get DC in the external circuit though AC is induced in the armature.

Such generators are the DC generators.

What are the similarities between the DC motor that we saw in the previous chapter and a DC generator?

- Permanent magnet.
-
-

Connect the output of a small DC generator to a galvanometer and rotate the armature continuously.

- How is the needle deflected?
- Is the direction of current changing?
- Is the magnitude of current the same?

Do you notice that the direction of current does not change and that the result is a pulsating current?

Graphical representation of *emf* obtained from an AC generator, a battery & a DC generator are given in the table,

Write down the peculiarities of the *emf* ?

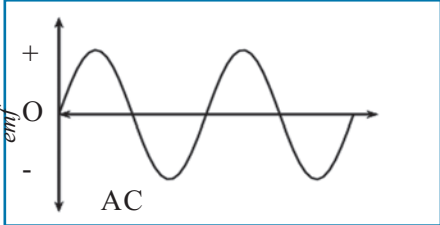
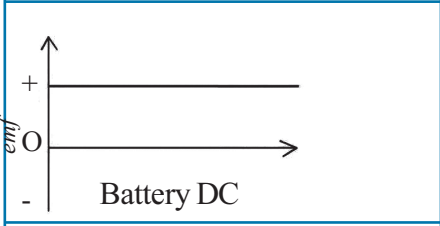
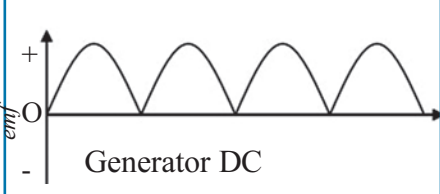
	<ul style="list-style-type: none"> • Direction changes continuously •
	<ul style="list-style-type: none"> • •
	<ul style="list-style-type: none"> • • <i>emf</i> increases and decreases.

Table 3.5

Haven't you understood how electromagnetic induction is made possible by using a magnet and a coiled conductor? Is electromagnetic induction possible in any other way?

Let's do an experiment.

Mutual Induction

As shown in Fig. 3.9, a few turns of finely insulated copper wire are wound at each end of a soft iron core (approx. 500 turns). The ends of one of the insulated copper wire are connected to a cell and a switch. The insulated copper wire which is wound on the other end of the soft iron rod is connected to a bulb.

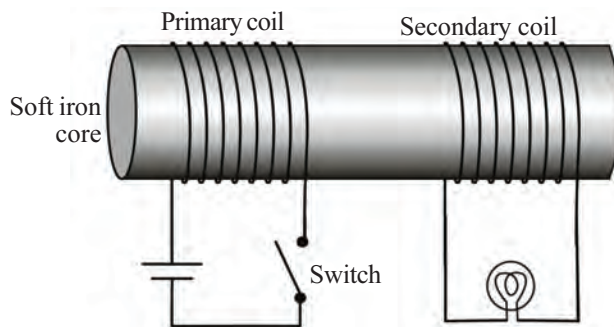


Fig. 3.8



- Turn on & turn off the switch continuously. What do you observe?
- If the switch is kept in the on position what do you observe?

Magnetic flux is formed around soft iron core when current is passed through the coil.

- On what occasions do the flux change?
- What are the occasions when current flows through the second coil?

The coil into which we give current for the production of magnetic field is the primary coil and the coil in which induced emf is generated is the secondary coil.

Can you suggest a method by which change can be brought in magnetic flux without switching on and off continuously?

If AC is given to the primary coil instead of DC, emf will be continuously induced in the secondary coil.

When an AC passes through the primary, a varying magnetic field is formed in and around the soft iron core. The secondary is situated in this varying magnetic field. This situation is similar to the moving of a magnet inside

the secondary coil. The flux change produced in the secondary coil induces an emf in it. This phenomenon is the mutual induction.

Consider two coils of wire kept side by side. When the strength or direction of the current in one coil changes, the magnetic flux around it changes. As a result, an emf is induced in the secondary coil. This phenomenon is the mutual induction

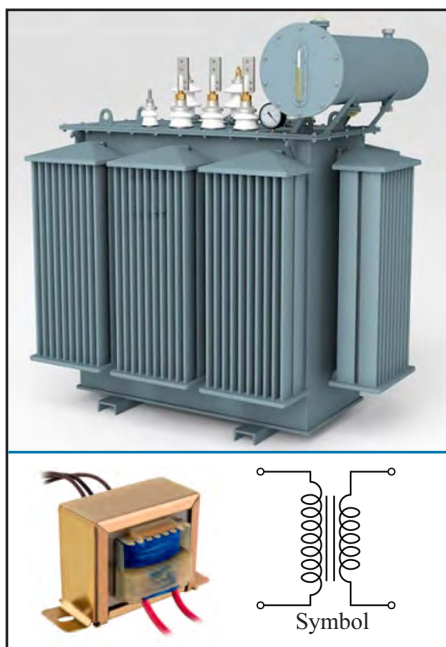
A transformer is a device that works on the principle of mutual induction.

Transformer

Transformer is a device for increasing or decreasing the voltage of an AC without any change in the electric power. Transformers are of two types.

The one which increases AC voltage is step up transformer. The one which decreases AC voltage is a step down transformer.

Examine the diagrams of step up and step down transformers and list out the differences in their designs.



Transformer
Fig. 3.9

Step up transformer	Step down transformer
<ul style="list-style-type: none"> Thick wires are used in the Primary. 	
<ul style="list-style-type: none"> 	
<ul style="list-style-type: none"> 	

Table 3.6

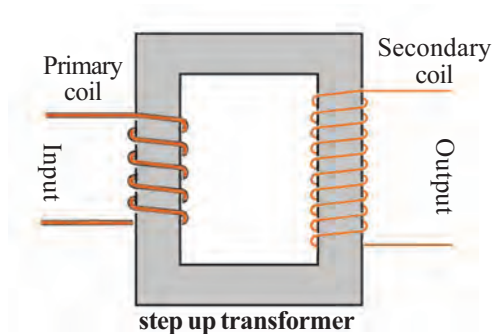


Fig. 3.10 (a)

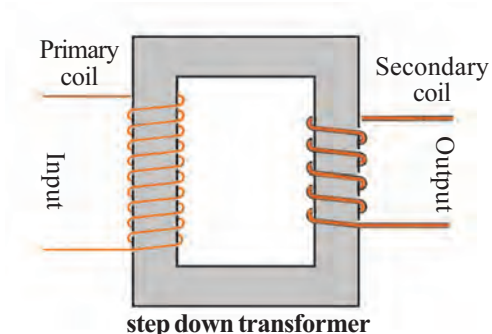


Fig. 3.10 (b)

The emf in each turn of the primary and the secondary coils will be the same. Let the emf in one turn be ϵ . Then, the emf in the primary is

$$V_p = N_p \times \epsilon$$

The induced emf in the secondary is

$$V_s = N_s \times \epsilon$$

Hence, V_s changes in accordance with the number of turns in the secondary. The voltage in the secondary and primary will be in the same proportion as that between the number of turns of the secondary and primary.

If V_s is the secondary voltage, V_p is the primary voltage, N_s is the number of turns in the secondary and N_p the number of turns in the primary in

a transformer then $\frac{V_s}{V_p} = \frac{N_s}{N_p}$.

Using this equation, complete the following table.

Primary coil		Secondary coil	
Number of turns N_p	Voltage V_p	Number of turns N_s	Voltage V_s
500	10 V	2500
.....	100 V	800	25 V
600	1800	120 V
12000	240 V	12 V

Table 3.7

- A transformer working on a 240 V AC supplies a voltage of 8 V to an electric bell in the circuit. The number of turns in the primary coil is 4800. Calculate the number of turns in the secondary coil.
- The input voltage of a transformer is 240 V AC. There are 80 turns in the secondary coil and 800 turns in the primary. What is the output voltage of the transformer?

The power in the primary and the secondary coils of a transformer is the same.

If there is no loss of power from a transformer, the power in the primary and in the secondary coils will be equal.

- If voltage and current are known, what is the formula for finding power?

$$\text{Power} = \text{Voltage} \times \text{Current}$$



- In a transformer, if the voltage of the primary is V_p and the current in the primary is I_p , voltage in the secondary is V_s and the current I_s , write down the formulae connecting them.

Power in the primary = \times

Power in the secondary = \times

In a transformer,

Power in the primary = Power in the secondary

That is,

$$V_p \times I_p = V_s \times I_s$$

$$\therefore \frac{I_p}{I_s} = \frac{V_s}{V_p}$$

In a step up transformer the voltage in the secondary coil is more and the current is less. But in a step down transformer the secondary voltage is less and the current is more.

- In a transformer without any loss in power, there are 5000 turns in the primary and 250 turns in the secondary. The primary voltage is 120 V and the primary current is 0.1 A. Find the voltage and current in the secondary.

Categorise the following relations appropriately as step up or step down transformers.

- $V_s > V_p$
- $V_s < V_p$
- $I_s < I_p$
- $I_s > I_p$
- $\frac{N_s}{N_p} < 1$
- $\frac{N_s}{N_p} > 1$

As a result of the flow of current through a solenoid, is there any chance of inducing an electric current in the same solenoid?

Self Induction

Let's examine the following experiments.

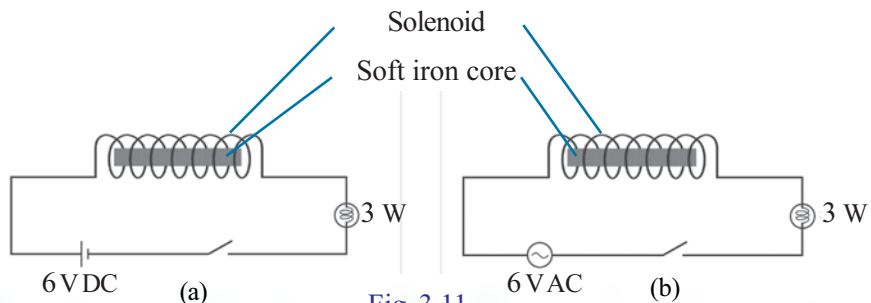


Fig. 3.11

The bulb in the circuit glows when the circuit is kept switched on.

In which circuit does the bulb give a light with low intensity? Why does the intensity of light decrease in that circuit? Based on the observations, answer the following questions.

- In which circuit is a magnetic field developed around the solenoid?
- In which circuit is a varying magnetic field developed around the solenoid?
- If so in which circuit is a continuous emf induced?

When AC passes through a solenoid, a changing magnetic field is generated around it. Due to this an induced emf is generated inside the solenoid. This induced emf is in a direction opposite to that applied on the coil. Hence this is a back emf. This back emf reduces the effective voltage in the circuit.

The change in magnetic flux due to the flow of an AC in a solenoid will generate a back emf in the same solenoid in a direction opposite to that applied to it. This phenomenon is known as the self induction.

Have you understood the reason behind the decrease in the intensity of light in the second circuit? Write it down in the science diary.

Inductor is a device which works on the principle of self Induction.

Inductor

An inductor is an insulated copper wire wound in a helical shape.

Inductors are coils used to oppose the changes in electric current in a circuit. They are used to reduce current in a circuit to the desired value without loss of power



Importance of Soft Iron

The ability to make more magnetic flux to concentrate inside it (permeability) is high for soft iron. Therefore by suitable arrangement of soft iron, the flux density in the desired region of a magnetic field can be increased. Moreover, in the presence of a magnetic field, soft iron gets magnetised very quickly. Similarly it gets demagnetized as soon as the magnetic field vanishes. This is another characteristic property of soft iron.

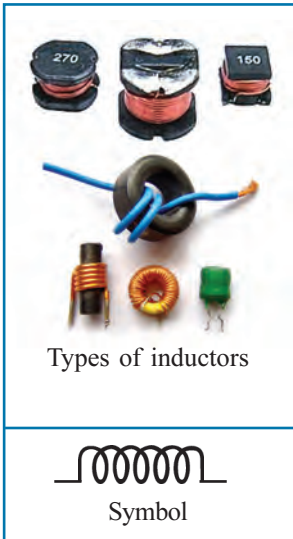


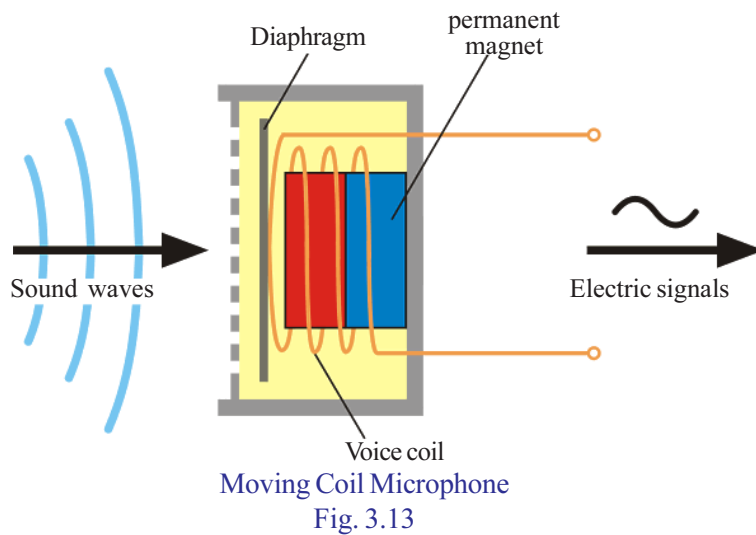
Fig. 3.12

- Inductors are widely used in AC circuits. Why?
- If resistors are used instead of inductors, what will be the disadvantage?
- Inductors are not used in DC circuits. Find out the reason and write it down in the science diary

You might have understood that generator, transformer, inductor etc., are devices that work based on the principle of electromagnetic induction. Moving coil microphone is another device that works based on the principle of electromagnetic induction.

Moving Coil Microphone

Analyse Fig.3.13 and answer the following questions.



- Which are the main parts of a moving coil microphone?

- Which is the moving part in it?

- If a sound is produced in front of a movable diaphragm, what will happen to the diaphragm?

- What happens to the voice coil then ?

- What will be the result?



The working of Moving coil microphone

The voice coil is situated in a magnetic field. The diaphragm connected to the voice coil vibrates in accordance with the sound waves falling on it. As a result, electrical signals corresponding to the sound waves are generated in the voice coil. In the microphone, mechanical energy is converted into electrical energy.

When a sound is produced in front of a microphone, electric signals in accordance with the sound is generated in the coil. The weak signals obtained from the microphone are strengthened by an amplifier.

The signals reaching the amplifier are strengthened and sent to the loud speaker. The loud speaker reproduces the original sound.

Didn't you realise the structure and working of a moving coil loud speaker from the previous chapter?

Find out the similarities and differences between a moving coil microphone and a moving coil loud speaker and write them down in the science diary.

What is the energy transformation that takes place in a moving coil microphone?

There are microphones working on various principles. Moving coil microphone is one among them.

Power Transmission and Distribution

The principle of electromagnetic induction is used worldwide to generate electricity on a large scale. AC generators are used to produce electricity for the purpose of distribution. How do we get mechanical energy for such generators?

Different types of Microphones

In addition to moving coil microphones, four more types of microphones are in use.

1. Carbon microphones

The main part of this is a small box called button containing carbon granules. It is designed in such way that a thin metal disc called the diaphragm presses against the button. The diaphragm vibrates in accordance with the sound waves and the corresponding electrical variations are produced. Carbon microphones are mainly used in telephones.

2. Crystal and ceramic microphones

The main part of this type of microphone is piezoelectric crystals. Piezoelectric crystals can generate electricity when they are subjected to pressure. Ham radios use crystal and ceramic microphones.

3. Ribbon microphones

The main part is a metallic ribbon suspended from within a magnetic field. When sound waves fall on the metal ribbon, the ribbon vibrates accordingly inside the magnetic field. The vibration of the ribbon in the magnetic field produces the flow of electricity.

4. Capacitor microphones

They are also known as condenser microphones. The main part of it is two thin metal discs arranged side by side. The flexible plate in the front works as a diaphragm. The plate at the back is not capable of motion. Sound waves vibrate the front plate. This causes a change in the current through the capacitor. This type of microphone is used in hearing aids.



Single Phase Generator and Three Phase generator

Single Phase Generators have only one set of coil in between the poles of a field magnet. Three Phase Generators are used for the large scale production of electricity.

In power generators, three armature coils are arranged around the field magnet at an angular separation of 120° . When the field magnet rotates, three alternating currents of different phases are generated simultaneously in the three armatures. In each armature, maximum and minimum *emfs* are generated at different instances. Such generators are three phase generators.

- Water stored in a dam
- Nuclear energy
-
-

Power stations are places where electricity is generated on a large scale for distribution. Three Phase AC Generators are used in power stations.

Write down the name of some power stations in Kerala.

- Idukki – Moolamattom
-
-

In India electricity is produced at 11 kV (11000 V) in power stations. When electricity is transmitted to distant places there is loss of energy in the conductors in the form of heat. This is known as transmission loss.

Heat is generated in accordance with the equation $H = I^2Rt$. In that case



- What are the methods to reduce the heat generated?

Since power transmission is a continuous process, reducing the time is not practically possible. There are technical difficulties in reducing the resistance of conductors as well.

- If current (I) is reduced to half, how much will be the reduction in heat? (half, one fourth)
- If current (I) is reduced to $\frac{1}{10}$ times how much will be the reduction in heat?

You must have now realised that heat loss can be reduced by reducing the current.

- How can we reduce the current without change in power? Find out on the basis of the equation $P = V \times I$.

The voltage is increased upto 220 kV at the power station itself (Depending on the distance to which the transmission is to be done, different voltages like 110 kV, 400 kV, are also made use of). As a result the current and loss of energy in the form of heat decreases. Later the voltage is lowered at different stages of power transmission and electricity is made available to the distribution transformer at 11 kV.

230 V required for house hold purposes is made available by distribution transformers. 400 V needed for industrial purposes are also obtained from distribution transformers.

4 wires are coming out from a distribution transformer. Of these one is neutral and the other three are phases. The neutral potential is zero. The potential difference between a phase and neutral is 230 V and that between any two phases is 400 V.

- What is the method to reduce the transmission loss?
- Which type of transformer is there in a power station?
- Which type of transformer is there in a sub station?
- Which type of transformer is a distribution transformer?
- If a person standing on the earth touches a phase line, will she get an electric shock? Why?
- Which are the lines essential for household electrification?

Household Electrification

Look at the pictorial representation of a household electric circuit (Tree system).

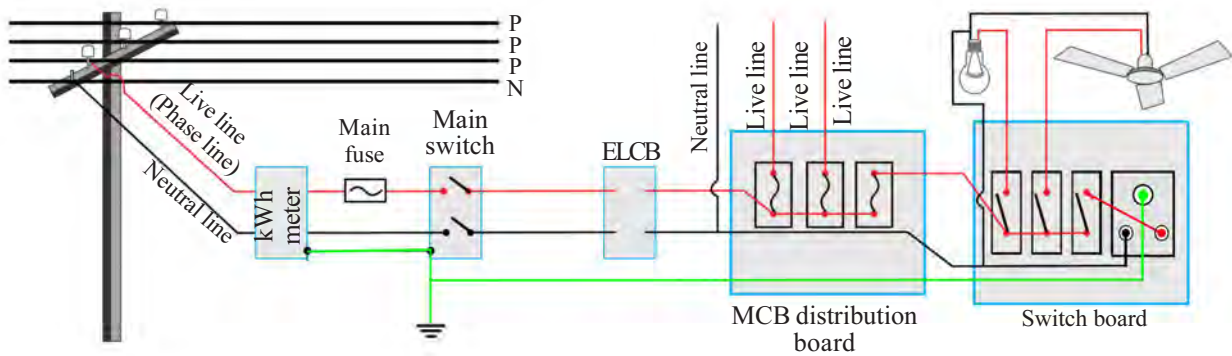
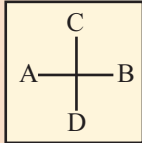


Fig. 3.14

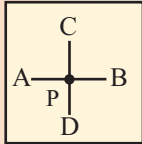
When conductors cross across

In a circuit diagram, it is the usual practice to draw as in Fig (i) the conductors AB and CD to indicate that they have no inter connection.



(i)

When it is drawn as shown in Fig (ii) it indicates that they are connected together at the point P.



(ii)

Analyse Fig.3.14 and find the answers to the questions given below.

- To which device is the electric line reaching our home connected first?

- From where does the earth line start?

- What is the use of a watt hour meter?

- In which line are the fuses connected?

- What is the function of the main switch? Where is its position in the circuit?



- In the household electrical circuit, which is the third line, other than the phase and the neutral?

- What are the colours used for wires in phase, neutral and earth lines?

- Where is the earth wire connected in a three pin socket?

- How are the household devices connected? Series/parallel

From a previous chapter you have understood the advantages of connecting devices in parallel. Write them down.

- Devices work according to the marked power
- Devices can be controlled using switches as per need.
-
-

Watt -Hour Meter

Watt – hour meter is a device that is used to measure electrical energy. Electrical energy is measured using the unit kilowatt hour. This is also known as a unit.

1 unit electrical energy = 1 kWh

*The commercial unit of electrical energy is kilowatt hour (kWh).
A device of power 1000 watt (1 kW), when used for one hour (1h), consumes one unit of electrical energy (1 kWh)*



Watt hour meter

Fig. 3.15

The following equation can be used to calculate the electrical energy used.

$$\text{Energy in kilowatt hour} = \frac{\text{Power in watt} \times \text{time in hour}}{1000}$$

- A grinder of power 750 W works for 2 hours. Calculate the energy consumed.

$$\text{Energy} = \frac{750 \times 2}{1000} = \frac{1500}{1000} = 1.5 \text{ unit (kWh)}$$

- In a house, 5 CF lamps each of 20 W, works for 4 hours, 4 fans each of 60 W work for 5 hours and a TV of 100 W works for 4 hours in a day. What will be the daily consumption shown by the watt hour meter?

The tariff instituted by KSEB for household consumers is given in Table 3.8. Analyse this table and explore the various possibilities for energy conservation. Prepare a project to plan the energy consumption at your home to minimise the cost of electricity.

You know that electricity is a form of energy that is extremely dangerous. Hence different safety measures are inbuilt in household circuit. (Hence household wiring is done by including so many safety measures)

Safety measures in household electrification

1. Safety Fuse

In the previous chapter you have studied how a safety fuse protects a circuit.

KSEB (Kerala State Electricity Board)	
Monthly Fixed Charges	(Rs / consumer)
Single phase	30
Three phase	80
Energy Charges	
Monthly consumption slab	Rs / unit
0-40 units (Applicable for BPL customers with connected load of and below 1000 watts)	1.50
0-50 units	2.90
51-100 units	3.40
101-150 units	4.50
151-200 units	6.10
201-250 units	7.30
251 -300 units	(For entire Unit) 5.50
301-350 units	(For entire Unit) 6 .20
351-400 units	(For entire Unit) 6 .50
401-500 units	(For entire Unit) 6.70
Above 500 units	(For entire Unit) 7.50

Table 3.8

- Which are the circumstances that lead to the flow of excess current in a household circuit?

- What happens to the circuit when there is an excess current in a circuit?



Circuit breaker

When the current increases due to overloading the bimetallic strip gets overheated and bends. Hence the circuit breaker gets switched off. (gets tripped) The current breaks. If there is short circuit, the MCB becomes tripped off due to the magnetic effect.

In an ELCB one end of the relay coil is connected to the outer metallic cover and the other end is earthed. If current leaks into the earth due to insulation failure or any other reason, a potential difference is developed between the ends of the relay coil. As a result ELCB gets tripped off if the current exceeds a particular limit. This is with the help of a relay. In RCCB there is a provision to distinguish between the phase current and neutral current and to break the circuit if needed.

- How does a safety fuse protect a circuit?

A circuit can be brought back to its original state by using a fuse wire of suitable amperage after rectifying the issue of excess current in it.

2. MCB (Miniature Circuit Breaker), ELCB (Earth Leakage Circuit Breaker)

MCB is a device that is used in the place of a fuse wire branch circuits. MCB automatically breaks the circuit whenever there is an excess flow of current due to short circuit or overloading. After rectifying the circuit we can switch on the MCB and make the circuit as it was. MCB works making use of heating and magnetic effects of electricity.

ELCB helps to break the circuit automatically whenever there is a current leak due to insulation failure or any other reason. Hence a person touching the electric circuit or a device does not get an electric shock. Nowadays RCCB, which ensures more safety than ELCB is made use of.



MCB ELCB



RCCB



- What are the differences between ordinary fuse and MCB?

- What is the advantage of MCB over a safety fuse?

- What is the function of ELCB/RCCB in the circuit?

3. Three pin Plug and Earthing

In order to ensure safety, three pin plugs are used in certain appliances. In the figure, which are the lines that are connected to the coil of the electric iron?

If the phase line comes into contact with the body of the appliance due to defects in the insulation, what happens to the person who touches the body of the appliance?

How can safety be ensured using a three pin plug?
Look at the figure.

- Which line comes into contact with the pin E?

- How does the earth pin differ from the other pins? Why is it made different in this way?

- Which part of the instrument is connected to the earth line?

The electricity we get in our homes is AC. But many devices are working on DC. Is TV working on AC or DC?

We get DC from a mobile phone battery. But we use AC for charging it. What may be the reason? Most of the devices that work only on DC work by converting AC into DC. Mobile charger is a

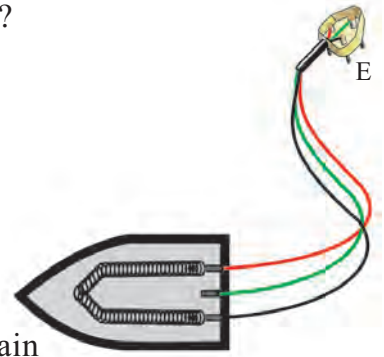


Fig. 3.16

Earthing for better safety

The pin E of a three pin plug comes into contact with the earth line. This pin is now connected to the body of the appliance. If at all the body comes into contact with an electric connection, electricity flows to the earth through the earth wire. The flow of current to the earth through a circuit of low resistance increases the current. As a result heat generated in the fuse wire increases and the circuit gets broken. This ensures the safety of instrument and the person handling it. The length and thickness of the earth pin is more than that of the other pins. Since the length is more, when the three pin is introduced into the socket, the earth pin comes into contact with the circuit first. When the three pin is pulled out of the socket, the earth pin will be the last to break the contact. Hence complete safety is ensured by the three pin plug. Since thick copper wire is used as the earth wire, a path of low resistance is created. Electricity can easily flow to the earth through this path.



device that converts AC into DC.

Classify the devices known to you as those working in AC and DC.	
Those working in AC	Those working in DC
<ul style="list-style-type: none"> • Fan • • • 	<ul style="list-style-type: none"> • Calculator • • •

Table 3.9

Are there devices working in both AC and DC?

List them down.

Rectifier is a device that converts AC into DC. AC is converted into DC after lowering the 230 V AC to 12 V or 6 V, as required for devices, using step down transformer or inductor. The main part of the rectifier is an electronic component named diode. This conducts current only in one direction. In addition to such rectifiers, rectifiers that make use of different electronic components are also in practice.

You might have understood that there are various inbuilt safety measures to ensure safety in household electrical circuits. Still we have to take some precautions while handling electric circuits and devices.

Electric Shock

Of the accidents related to electricity that occur in India about 10% is taking place in our state. Electric shock often leads to death itself. Hence electricity is to be handled with utmost concern for safety. Electric shock occurs when we touch bare wires or cable with damaged insulation or when lightning strikes. Severe injuries may occur when current flows through our body.

In addition to the electric shock, blisters may also occur. If somebody gets an electric shock, the main switch should be switched off immediately. Separate the electrocuted person using a dry wooden piece or a dry insulator material. Never touch the affected person using bare hands.

Sometimes high voltage shocks may not cause any damage. Even then one should seek medical help immediately, because it may affect

the brain. Epilepsy, depression, anxiety etc., may occur. Even if the voltage is small it may lead to unconsciousness, damage to touching sensation decrease in vision and hearing disability etc. Let us see what are the precautions to be taken to avoid electric shock.

Precautions

- Never handle electric equipments or operate switches when the hands are wet.
- Insert plug pins into socket and withdraw them only after switching off.
- Do not operate devices of high power using ordinary sockets.
- Wear rubber footwear while operating electric devices.
- Do not touch the interior parts of the cable TV adapters. Ensure that there is an insulated cap for the adapters.
- Do not fly kites near electric lines.
- Do not use table fan to dry hair.
- Ensure that there are no tall buildings or tall trees near electric lines.
- Ensure that the main switch and ELCB are switched off when maintenance work is being carried out at home.

Precautions during some Special Circumstances

- During lightning, avoid doing any work that will bring you in contact with electric circuits. (There is a possibility of excess current in the circuit during lightning)
- Disconnect the plugs from the socket whenever there is a chance of lightning.
- During rain and wind, electric lines are likely to touch the ground. This may cause danger. We have to be cautious on such occasions.
- If water enters home due to floods or other reasons, disconnect electric connections. Reconnect it only after ensuring that the main switch and the switch board are perfectly dry.

•

First aid to be given in the case of electric shock

As a result of electric shock, the body temperature of the victim decreases, viscosity of blood increases and clotting of blood occurs. In addition, muscles of the body contract.

First aid should be given only after disconnecting the victim from the electric wire.

How to provide the first aid:

- Raise the temperature of the body by massaging.
- Give artificial respiration.
- Massage the muscles and bring them to the original condition.
- Start first aid for the functioning of the heart (Apply pressure on the chest regularly)



Fig. 3.17

- Take the person to the nearest hospital immediately.

Electricity is an integral part of our day – to – day life. This energy is to be conserved for tomorrow . Hence its consumption should be reduced to the minimum possible. “*Saving electricity is equivalent to generating electricity.*” Electricity is highly useful, at the same time it is a dangerous form of energy. Hence electrical appliances should be handled with extreme care.

Making House Hold Circuit















You are now familiar with circuit related to a household circuit. Shouldn't you know how to make such a circuit practically?

What are the materials required? Distinguish the following devices and write down their uses.



Component/Equipment	Name/ Use	Component/Equipment	Name/ Use
	One way switch		RCCB
	Two way switch		MCB
	Three pin socket		Kit Kat Fuse
	Ceiling rose		Switch board
	ELCB		Meter
	Regulator		Main switch
	Indicator		Bulb holder

Table 3.10

Component/Equipment	Name/ Use	Component/Equipment	Name/ Use
	Clamp Ammeter		Plier
	Multimeter		Gloves
	AC Voltmeter		Insulation tape
	Wire stripper		Wire (cable)
	Screwdriver (*)		PVC Pipe fittings
	Screwdriver (-)		PVC channel
	Tester		PVC Pipe

-
-
-
-

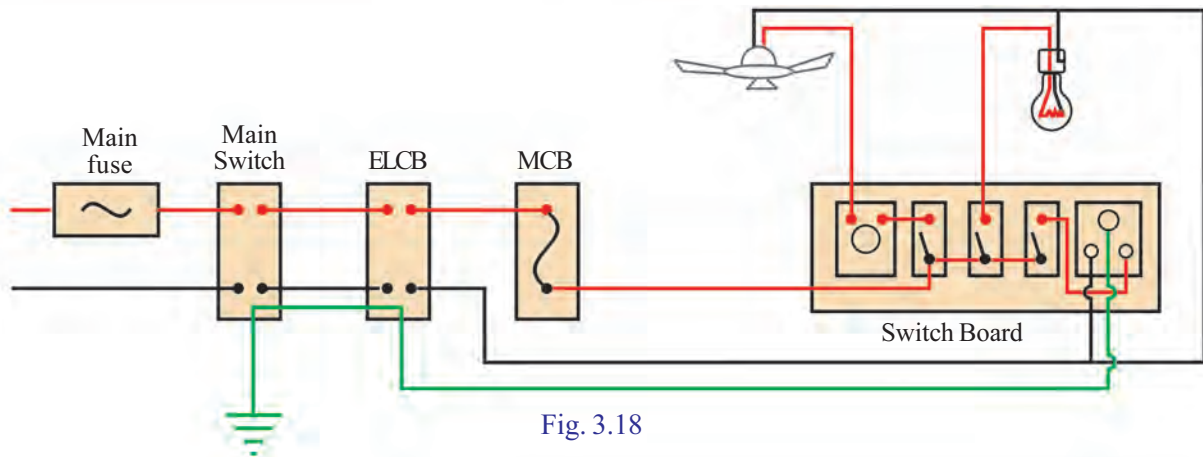


Fig. 3.18

No.	Material	Rating	No.
1.	Plywood/softwood	1.5m×1m×6mm	1
2.	Distribution board		1
3.	Main fuse	16 A, 230 V	1
4.	Main switch	16 A, 230 V	1
5.	ELCB	Single phase	1
6.	MCB	6 A, 230 V	1
7.	Regulator	60 W, 230 V	1
8.	Switch	6 A, 230 V	3
9.	3 pin socket	6 A, 230 V	1
10.	Switch box	3 way D	1
11.	Bulb	LED 9 W, 230 V	1
12.	Bulb holder	6 A, 230 V	1
13.	Junction box	20 mm	2
14.	Ceiling rose	20 mm	1
15.	PVC pipe	20 mm	2 m
16.	Ceiling fan	60 W, 230 V	1
17.	Clamp	20 mm	4
18.	Screw	12 mm	12
19.	Wire (red, black)	1 mm ²	3 m each
20.	Earth wire 16/14 SWG	16/14 SWG	2 m
21.	Sleeve (green) (to cover the earth wire)	16/14 SWG	2 m
22.	Tester		1
23.	Plier	150 mm	1
24.	Screw driver	150 mm	1
25.	hammer		1

Table 3.11

Construct such a circuit in a plywood as shown in Fig 3.19. The list of materials required and the number of items are given in the table.

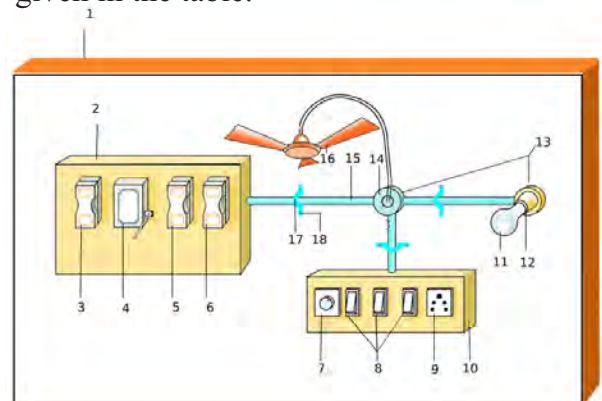


Fig. 3.19

Electrification is to be done using materials according to BIS Marks/conditions according to the Indian Electricity Rules (IE Rules -1956)

After constructing the circuit with the help of teacher or an electrician make sure that the connections are correct. Connect the phase, neutral and earth in your cardboard to a three pin plug and connect it to a power plug at home.

Beware:

This work is to be done under the supervision of experts.

Do the following to know whether the circuit works properly or not.

- Using a tester, examine whether the current reaches the socket or not.
- Operate the bulb using a switch.
- Operate the fan using a switch and adjust the speed using a regulator.
- Charge a mobile using three pin socket.
- Check the safety of the circuit by short circuiting the socket.
- Write down the changes to be done in the circuit if an induction cooker is to be used.

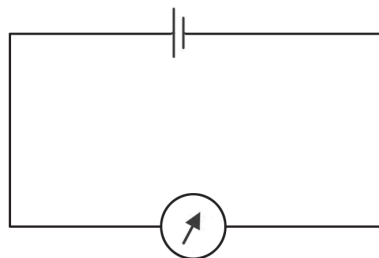
Additional activities

- Find out how a bulb can be operated using two switches (two way switch). Draw the circuit and construct the circuit.
- Construct an extension cord having two three pin plugs and a switch.

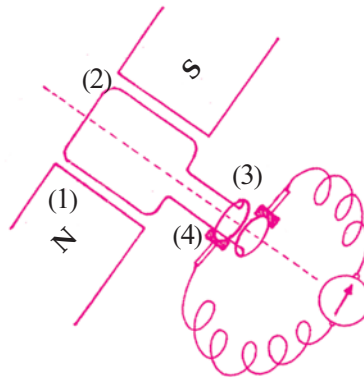


Let us assess

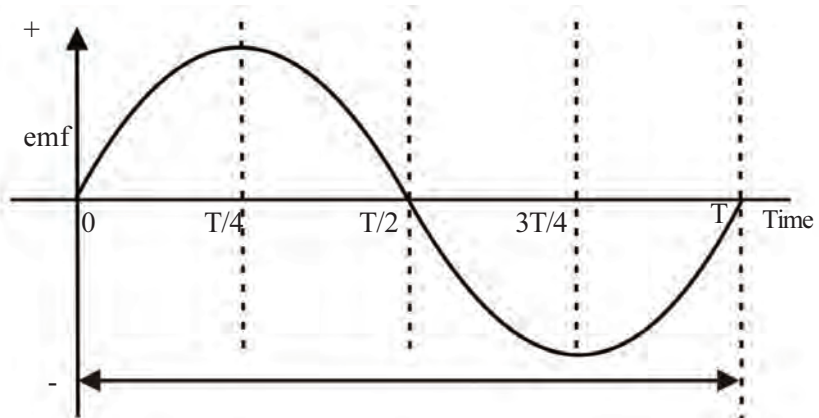
1. Write down the names of some devices that work based on the principle of electromagnetic induction.
2. What are the components essential for proving electromagnetic induction experimentally?
3. Which are the factors that affect the induced emf in electromagnetic induction?
4. Take a used cell from a calculator or remote control and connect it to a galvanometer as shown in the figure. What do you observe?



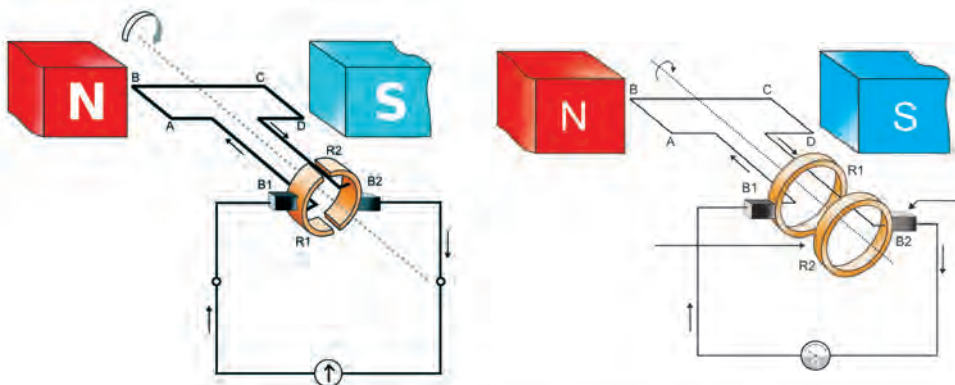
5. Write down the names of DC sources.
- 6.



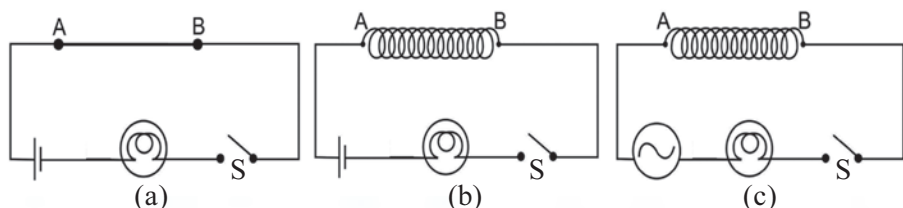
- (a) Write down the names of parts numbered.
 - (b) State the working principle of this device.
7. Write down the special features of AC and DC.
 8. Analyse the given graph and find out the instances at which the emf is maximum and minimum.



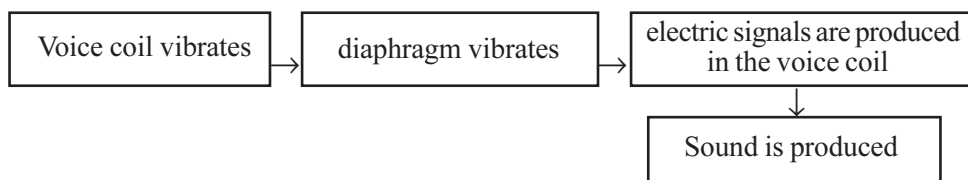
9. There is only one type of generator – AC generator. Write down your responses about this statement.
10. Line diagrams of a generator are given.



- a) What is the speciality of the electricity reaching the galvanometer if the armatures of both the generators are made to rotate?
 - b) What is the speciality of the electricity reaching the galvanometer if the field magnets of both the generators are made to rotate?
 - c) Draw the graphical representation of electricity obtained in both.
11. Electromagnetic induction is
- a) charging a substance
 - b) process of developing a magnetic field around a coil by passing electricity through a coil
 - c) process of rotating the armature of a generator.
 - d) process of making electricity by the relative motion of a magnet or a coiled conductor.
12. Which is the device used to generate electricity?
- a) generator b) galvanometer
 - c) motor d) ammeter
13. Write down the similarities and differences in the structure of an AC generator and a DC generator.
14. A conductor hung horizontally in the north south direction is connected to a galvanometer. The conductor is situated in a magnetic field acting in the East-west direction. In which direction should you move the conductor if maximum current is to be induced in the conductor in the north south direction? Justify your answer.
- a) towards east b) downwards
 - c) upwards d) towards north
15. Copper wires of the same length and thickness are connected to points A and B in all the three circuits. In circuit (a) copper wire is not coiled. In circuits (b) and (c), the copper wire is coiled. Observe the circuits and answer the following questions.



- (a) When circuit (a) is switched on, what do you observe?
- (b) When circuit (b) is switched on, what change do you observe in the intensity of light? Justify your answer.
- (c) When circuit (c) is switched on, what change do you observe in the intensity of light? Justify your answer.
16. The current in the secondary coil of a transformer is 1 A and that in the primary is 0.5 A.
- (a) What type of a transformer is this?
- (b) If 200 V is available in the secondary coil of this transformer, what is the voltage in the primary?
- (c) Explain the working principle of a transformer
17. In connection with the working of a microphone, a few statements are given in boxes.
Arrange them in the proper sequence.



18. Thick insulated copper wires are used in the primary coil of a step up transformer and in the secondary of a step down transformer. What is the necessity of this?
19. Which situation causes short circuit?
20. What is the role of earthing wire in a household circuit?
21. Why do we say that metallic devices should be earthed?
22. An electric heater calibrated 1.5 kW, 230 V is connected to a house hold branch circuit having 5 A fuse wire and is made to work. What will happen?
23. Which are the devices connected in series in a household circuit?
24. What can be done to save electrical energy in schools and houses?
25. Why do some mobile phones use three pin plugs?



Extended activities

1. Make coils of different number of turns using insulated copper wire. Use magnets of different strengths to produce induced emf. Present this activity in the science club.
2. Michael Faraday, the Father of electricity, did not even get elementary education. Are you not inspired by the achievements of Faraday in the field of science?
Conduct a seminar on “*Contributions of Faraday and the hard work behind it.*”
3. Energy is precious, especially electrical energy. Society must be convinced of the necessity of reducing the consumption of electrical energy. Prepare and propagate posters for this purpose.
4. Compare the induced current obtained when the armature coil rotates once in between the poles of a magnet, and the induced current obtained when the experiment using a magnet and coil was performed.
5. Exhibit a model of electrical distribution network.
6. Draw an electrical circuit containing the electrical appliances required for your class room.
7. How can the earthing be done in order to ensure safety in electrical circuits? Discuss and prepare a note.
8. Observe and record the meter reading in your house for 10 consecutive days. Based on this, find out the average consumption per day. Find out methods to reduce consumption and record them. Present your findings in the Energy Club.
9. Under the auspices of science club conduct an awareness class about electric shock.
10. With the help of a doctor, find out how to administer cardiopulmonary resuscitation (CPR) on an electrocuted person when she is either unconscious or unable to breathe.



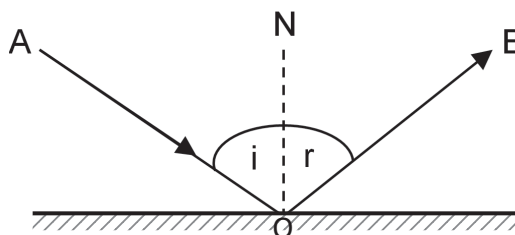
4

Reflection of Light



When she saw these words on the mirror “Objects seen in the mirror are closer than they appear”, the girl had a doubt. Have you also felt the same? Light is a form of energy essentially required to see objects. Which are the phenomena helpful for this? You have studied about reflection and refraction in previous classes. Let’s have more discussion on the reflection of light. Light falling on the surface of an object comes back to the same medium. This is reflection of light. We also know that such a change occurs in accordance with the laws of reflection of light.

Observe the figure.



Plane mirror
Fig. 4.1

- Which is the incident ray?
- Which is the reflected ray?
- Is there any relation between the angle of incidence and the angle of reflection?
- Are the incident ray, reflected ray and normal to the mirror at the point of incidence in the different planes?

Let's write down the laws of reflection.

When light is reflected from a smooth surface, the angle of incidence and angle of reflection are equal. The incident ray, reflected ray and normal to the surface are in the same plane.

A beam of light incident on two surfaces with different properties is depicted below.

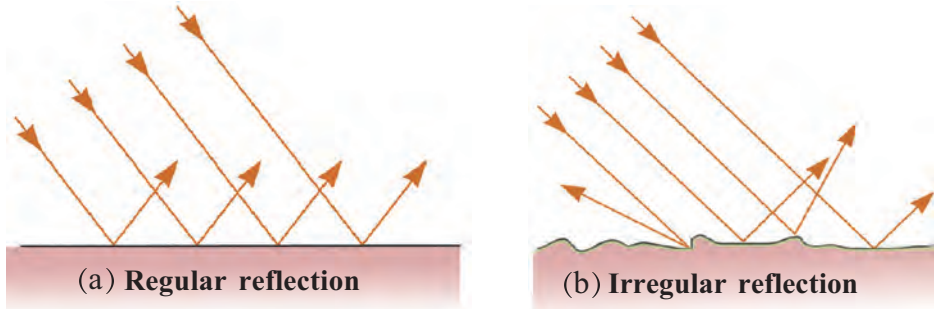


Fig. 4.2

What difference is seen between the surfaces of the two objects? In Fig. 4.2(b) are the rays of light travelling parallel after reflection? When light falls on a rough surface, it undergoes an irregular reflection. This is scattered reflection. Here light undergoes reflection but no image is formed though. In the dust particles of the atmosphere, light undergoes scattered reflection. This is scattering. We shall learn more about scattering in another chapter.

In Fig. 4.2(a) regular reflection is depicted. Can you give a definition for such reflections by observing the figure?

We are familiar with plane mirrors and spherical mirrors. In such mirrors light undergoes regular reflection. Let's try to learn more about reflection of light and image formations.

Image Formation by a Plane Mirror

We have seen the laws of reflection of light. Can you locate the position of image and its nature by making use of these laws?

Arrange a source of light at a point O in front of a plane mirror. Consider that OA and OB are two rays of light incident obliquely on the mirror.

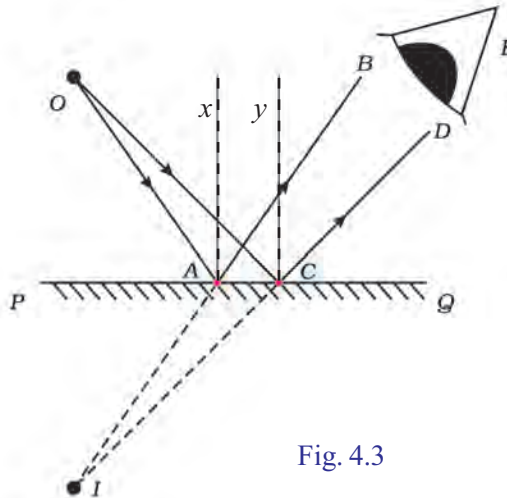


Fig. 4.3

According to the laws of reflection the reflected rays AB and CD can be drawn with respect to the normals x and y . What will happen if these rays are extended backwards?

Don't they meet at a point I ? Isn't here that the image is formed?

Record in your science diary the following features about the images formed here.

- The distance from the mirror to the object and the image from the mirror.
- Is the image real or virtual?
- The size of the image

Images are formed when light hitting on objects undergoes reflection at the mirrors. Can you increase the number of reflections by increasing the number of mirrors? If yes how many images can we see at a time by using two mirrors?

Multiple Reflection and Image Formation

Arrange two plane mirrors in such a way that their edges are in contact as shown in the figure. Place a burning candle in between them. How many images of candle can you see? Find out the number of images

Angle (θ)	Number of images (n)
45	
60	
90	
120	
180	

Table 4.1

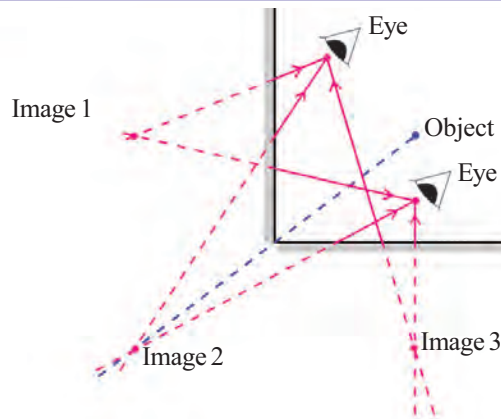


Fig. 4.4

- How many images can be seen when viewed from A and B?
- What if viewed from other positions in between the mirrors?
- How much is the angle between the mirrors?
- What is the relation between the angle between the mirrors and the number of images?

$$\text{Number of images } n = \frac{360}{\theta} - 1$$

by changing the angle between the mirrors. Record your observations in the science diary.

Field of View of Mirrors and the Nature of Images

We know that there are different types of mirrors like plane mirror, concave mirror and convex mirror. We make use of them in different situations based on the features like position of image, size of image and nature of image. Observe the table given below. The position of image and the features of image when objects are placed in different positions in front of different types of mirrors are tabulated.

Plane mirror	Convex mirror	Concave mirror	
		Position of object	Position of image and features
Image is behind the mirror. Distance of object from the mirror and distance of the image from the mirror are equal. The image is virtual, erect and is of the same size as that of the object.	Image is formed in between the pole of the mirror and the principal focus. The image is diminished, virtual and erect.	At infinity	
		Beyond C	
		At C	
		Between C and F	
		At F	
		Between F and P	

Table 4.2

By completing the Table 4.2 and by analysing it, we can reach the following inferences. Can you write down some situations in daily life in which we can make use of the inferences?

Mirror	Inferences (Position of image and features)	Situations making use of them
Plane mirror	The image is behind the mirror. Distance to object and distance to image from the mirror are the same. The image is virtual, erect and is of the same size as that of the object.	For observing the face.
Convex mirror	Image is always formed in between the pole of the mirror and the principal focus. The image is diminished, virtual and erect.	Used as rear view mirror
Concave mirror	Converges distant rays to the principal focus.	
Concave mirror	Reflects the rays coming from principal focus as parallel rays.	
Concave mirror	For the object placed between principal focus and pole, the images formed are enlarged and erect.	

Table 4.3

The field of view of a mirror is the maximum range of the vision through the mirror. Each mirror differs in their field of view just as they differ in the nature of images formed. Of all the mirrors we have understood the field of view is maximum for a convex mirror. It must be clear now why convex mirrors are used as rear view mirrors?

While using mirrors on different occasions we will have to find out the focal length of the mirror. How do we find out the focal length of such mirrors? Let's try to derive a formula for finding out the focal length by means of a suitable experiment.

Mirror Equation and Focal Length

Draw a straight line on a table as shown in the figure. At one end of the line, place a concave mirror of focal length 20 cm. Mark principal focus (F) and centre of curvature (C) on the line. Fix a burning candle on the principal focus in such a way that it is at a slight distance from the centre of curvature. Arrange a screen in such a way that a clear image is obtained on the screen.

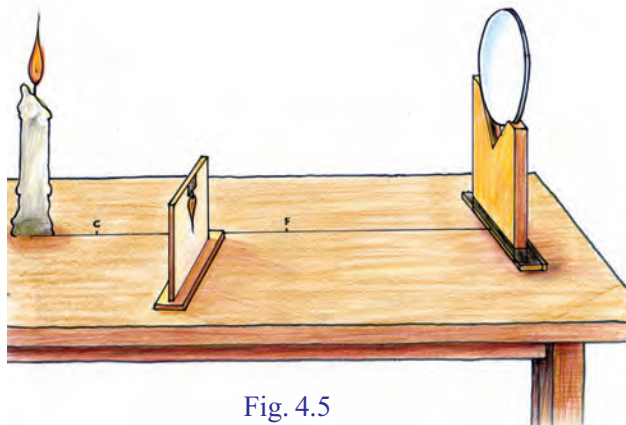


Fig. 4.5

- What is the position and features of the image?
- Observe the change in position of image and features on changing the position of the candle.

Consider u as the distance of the object from the mirror and v as the distance to the image from the mirror. Measure them and tabulate. Repeat the activity by changing the position of the object.

Sl. No.	Distance to object u cm	Distance to image v cm	$\frac{uv}{u+v}$
1	25		
2	30		
3	40		

Table 4.4 average value =

Aren't the focal length of the mirror and the average value of $\frac{uv}{u+v}$ obtained from the table the same?

From this it can be understood that focal length $f = \frac{uv}{u+v}$

On rearranging the expression $f = \frac{uv}{u+v}$, we get $\frac{1}{f} = \frac{1}{u} + \frac{1}{v}$

This is known as mirror equation.

While using different types of mirrors, the position and nature of image changes in accordance with the change in the position of the object. On such occasions finding the size and nature of image is also equally important as finding the focal length. New Cartesian Sign Convention has been formulated for this purpose.

New Cartesian Sign Convention

In all experiments related to lenses and mirrors the distances are measured in the same way as in graphs.

- Distances are measured considering the Pole of the mirror as the origin (O).
- Those measured to the right from O are positive and those in the opposite direction are negative.
- Distances measured upwards from X axis are positive and those downwards are negative. The incident ray is to be considered as travelling from left to right.



Record the measurements shown in the figure using the New Cartesian Sign Convention.

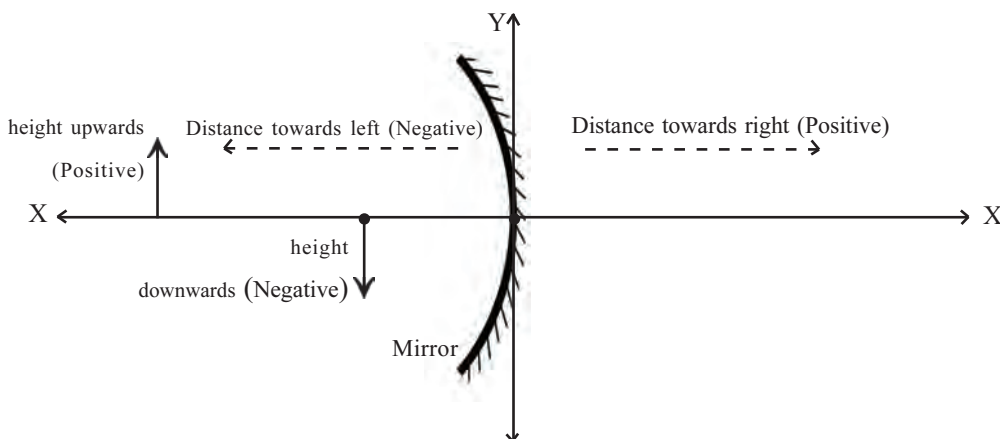


Fig. 4.6

Distance to the object from the mirror (u) =

Distance to the image from the mirror (v) =

Height of object (OB) =

Height of image (IM) =

The given figure shows the image formation by a concave mirror. Analyse the figure and write down different measures using New Cartesian Sign Convention.

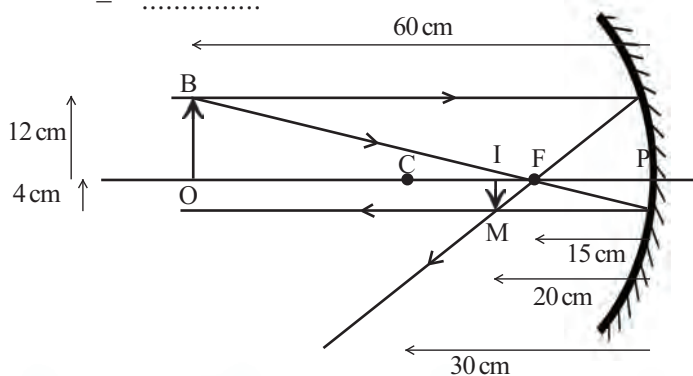


Fig. 4.7

Distance of object from the mirror, (u)	-60 cm
Distance of image from the mirror, (v)	
Focal length (f)	
Radius of curvature (r)	-30 cm
Height of object (OB)	+12 cm
Height of image (IM)	

Table 4.5

- When an object is placed in front of a concave mirror at a distance 30 cm from an image is obtained on a screen at a distance of 20 cm from the mirror. Find the focal length of the mirror.

$$u = -30 \text{ cm} \qquad v = -20 \text{ cm}$$

$$f = \frac{uv}{u+v} = \frac{(-30) \times (-20)}{(-30-20)} = -12 \text{ cm}$$

- An object is placed in front of a concave mirror 20 cm away from it. If its focal length is 40 cm, locate the position of image and its nature.

Is there any relationship between the position of image and the size of the image?

Let's find out. We had used a candle in the experiment for finding out the focal length. Replace it with a slit to carry out the experiment.

Find out the height of object (h_o), height of image (h_i), position of object (u) and position of image (v) using New Cartesian Sign Convention and tabulate them. (The height of image h_i can be directly measured by fixing a graph paper on the screen)

Focal length f (cm)	Distance to object u (cm)	Distance to image v (cm)	$\frac{v}{u}$	h_o (cm)	h_i (cm)	$\frac{h_i}{h_o}$
20						
20						
20						

Table 4.6

$$\text{average } \frac{v}{u} = \qquad \text{average } \frac{h_i}{h_o} =$$

$\frac{h_i}{h_o}$ is magnification. Does it have any relation with the value of $\frac{v}{u}$?

Try to write it down.

Let's see how this can be proved mathematically.

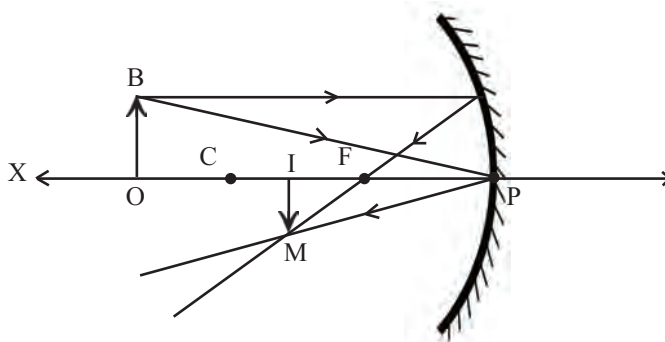


Fig. 4.8

The figure shows the image formation when an object is placed beyond the centre of curvature C. The ray parallel and close to the principal axis has been considered. In the figure OBP and IMP are similar triangles according to the concept of similarity. Let's write down the ratio of corresponding sides of similar triangles.

$$\frac{IM}{OB} = \frac{IP}{OP}$$

In the figure, $IM = h_i$, $OB = h_o$, $IP = v$, $OP = u$. On substituting in the

above equation we get $\frac{h_i}{h_o} = \frac{v}{u}$. On writing this equation in

accordance with the New Cartesian Sign Convention we get

$h_o = \text{positive}$, $h_i = \text{negative}$, $u = \text{negative}$, $v = \text{negative}$.

that is,
$$\frac{-h_i}{h_o} = \frac{-v}{-u}$$

$$\frac{-h_i}{h_o} = \frac{v}{u}$$

But
$$m = \frac{h_i}{h_o}$$

Hence
$$m = \frac{h_i}{h_o} = \frac{-v}{u}$$

Magnification is $m = \frac{h_i}{h_o} = \frac{-v}{u}$

- When an object of height 6 cm is placed in front of a concave mirror at a distance 10 cm away from it, an image is obtained 16 cm away, on the same side. Find out the height of image and magnification.

Distance to object $u = -10$ cm

Distance to image $v = -16$ cm

Height of object $h_o = +6$ cm

Height of image $h_i = ?$

$$\begin{aligned} \text{Magnification } m &= \frac{-v}{u} \\ &= -\left(\frac{-16}{-10}\right) \\ &= -1.6 \end{aligned}$$

$$\begin{aligned} \text{Magnification } m &= \frac{h_i}{h_o} \\ h_i &= m \times h_o \\ &= -1.6 \times (+6) \end{aligned}$$

Height of image $h_i = -9.6$ cm

- An object is placed 8 cm away in front of a concave mirror of focal length 5 cm. Find out the position of image and magnification. Find out whether the image is inverted or erect by drawing the ray diagram on a graph paper.

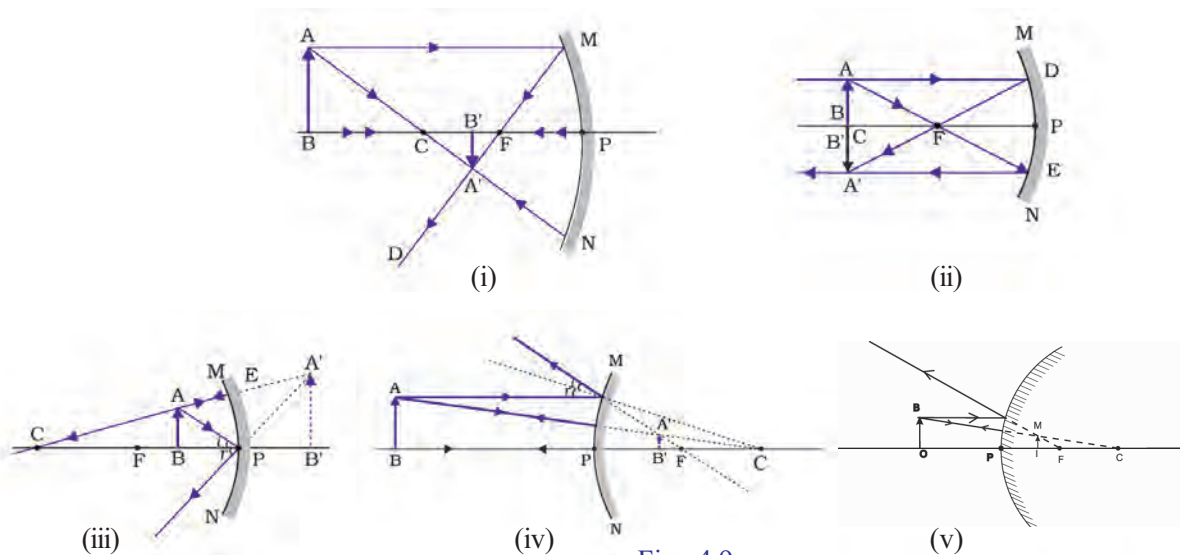


Fig. 4.9

Fig	h_i	h_o	Magnification $m = \frac{h_i}{h_o}$	Erect, virtual/ inverted, real	Size is same as that of the object/ magnified / diminished
Fig 1	Negative	Positive	Negative	inverted, real	diminished
Fig 2					
Fig 3					
Fig 4					
Fig 5					

Table 4.7

What are the features of an image that is obtained from magnification? Observe the given figures and complete the table using New Cartesian Sign Convention.

Analyse the table and mark the correct statements.

- When magnification is 1, the size of the image and the size of the object are equal.
- When magnification is more than 1, the size of the image is greater than the size of the object.
- When magnification is less than 1, the size of the image is smaller than the size of the object.
- When the magnification is positive, image is real and inverted.
- When the magnification is negative, image is virtual and erect.

From the above table, find out which mirror always gives an erect and diminished image and write it down.

The image formed by a convex mirror is always erect and diminished. Hence the driver who sees the image of vehicles on the mirror develops a feeling that the vehicles coming from behind are at a greater distance. This may turn out to be dangerous. Now have you understood why it is written on rear view mirrors that “Objects in the mirror are closer than they appear”.



Let us assess

1. A dental doctor uses a mirror of focal length 8 cm. To see the teeth clearly what should be the maximum distance between the teeth and the mirror? Justify your answer. Which type of mirror has been used by the doctor?
2. Imagine that a spherical mirror gives an image magnified 5 times at a distance 5 m. If so determine whether the mirror is concave or convex. How much will be the focal length of the mirror?
3. A motor cyclist observes a car coming from behind with a magnification $1/6$. If the actual distance between the car and the bike is 30 m calculate the radius of curvature of the mirror.
4. A shaving mirror of focal length 72 cm is kept in a beauty clinic. A man uses it standing 18 cm away from the mirror. At what distance will the image be formed? Is the image real or virtual? What is the magnification of the image?
5. Wrap a rubber ball of diameter 12 cm completely with an aluminium foil and make the surfaces smooth. Where will be the image of an object kept 12 cm away from the centre of the ball? Is the image real or virtual?
6. We are able to read a book since light falling on a surface gets reflected from the book and reaches the eye. But on such occasions we cannot see our images like that from a mirror. Explain why?
7. Is the image formed by a plane mirror real or virtual? Write an instance when such a mirror gives an inverted image.



Extended activities

1. Make toys which make use of multiple reflections.
2. Construct a reflecting telescope.
3. Paint half the reflecting surface of a concave mirror black. What change is observed in the position and the nature of the image? Justify your opinion.



Notes

A series of 20 horizontal dashed lines, evenly spaced, filling the majority of the page below the 'Notes' header. These lines are intended for students to write their notes on.

Notes

A series of 20 horizontal dashed lines for writing notes.

While using electricity...

Electricity has become an indispensable part of our day-to-day life. Its consumption has increased and hence the hazards due to this have also increased. Of all the electrical hazards reported in India 10 per cent are from our state. Hence there is no need for specific mentioning to ensure the importance of precautionary measures from electricity related hazards.

Safety measures to be adopted:

- Do not operate switches with wet fingers.
- Do not dry hair using a table fan.
- Do not touch the inner part of the adaptor of a TV. Ensure that the adaptor has a cap which is a non-conductor.
- Do not touch on broken electric wires.
- Do not fly kites near electrical lines.
- Do not use metallic pipes or iron hooks carelessly near electric lines.
- Do not lean against electric posts or stay wires. Cattle should not be tied to them. Do not allow plants or creepers grow on them.
- Switch off the main switch in case of fire on electric appliances or on their vicinity.
- Do not pour water over electric lines or appliances to put out fire. Instead, use dry sand or dry powder type fire extinguishers.
- Use only the electric appliances carrying ISI mark.
- Do not use plastic wires for temporary connections to decorations.
- If a person succumbs to electric shock, he/she should be touched only after disconnecting the electrical contact.
- Detach the victim from the electric connection using dry wooden planks or some dry material which is not a conductor.
- Switch off the main switch immediately, in case electric shock is noted.

Electricity saved is equivalent to electricity generated