

MATHEMATICS

Standard III

Part - I



Government of Kerala

DEPARTMENT OF EDUCATION

State Council of Educational Research and Training (SCERT); Kerala

2016

THE NATIONAL ANTHEM

Jana-gana-mana adhinayaka, jaya he
Bharatha-bhagya-vidhata.
Punjab-Sindh-Gujarat-Maratha
Dravida-Utkala-Banga
Vindhya-Himachala-Yamuna-Ganga
Uchchala-Jaladhi-taranga
Tava subha name jage,
Tava subha asisa mage,
Gahe tava jaya gatha.
Jana-gana-mangala-dayaka jaya he
Bharatha-bhagya-vidhata.
Jaya he, jaya he, jaya he,
Jaya jaya jaya, jaya he!

PLEDGE

India is my country. All Indians are my brothers and sisters.

I love my country, and I am proud of its rich and varied heritage. I shall always strive to be worthy of it.

I shall give respect to my parents, teachers and all elders and treat everyone with courtesy.

I pledge my devotion to my country and my people. In their well-being and prosperity alone lies my happiness.

Prepared by :

State Council of Educational Research and Training (SCERT)

Poojappura, Thiruvananthapuram 695012, Kerala

Website : www.scertkerala.gov.in

e-mail : scertkerala@gmail.com

Phone : 0471 - 2341883, Fax : 0471 - 2341869

Typesetting and Layout : SCERT

First Edition : 2014, Reprint : 2016

Printed at : KBPS, Kakkanad, Kochi - 30

© Department of Education, Government of Kerala



My dear students,

Numbers, figures, patterns!

We have entered into a new world of mathematics.

Let us learn mathematics to add, to subtract, to multiply.

Let us go forward, playing and enjoying with our friends discovering new things and correcting our past mistakes.

Let us move ahead with confidence and get ready for more exciting mathematical experiences!

With best wishes,



Dr. P. A. Fathima

Director
SCERT Kerala

TEXTBOOK DEVELOPMENT TEAM

PARTICIPANTS

Ashraf C.V.

Asst. Teacher, Vanimel UPS, Kozhikkode

Unnikrishnan M.V.

HSA, GHS Kumbla, Kasaragod

Prasanth K.P.

UPSA, Devadar UP School, Nediyirupp,
Malappuram

Narayananunni M.P.

Lecturer, DIET Palakkad

Vasu K.G.

AEO (Rtd.) Tirur

Syam Kumar

HSA, JNHS Kadukulanhi

Sambasivan

Master Trainer, IT@School
Thiruvananthapuram

Suresh C.

Trainer, BRC Thanur, Malappuram

Experts

Baiju S.

Asst. Prof., Govt. College, Karyavattam, Thiruvananthapuram

Dr. Radhakrishnan Chettiyar

Prof. (Rtd) University College, Thiruvananthapuram

Artists

Kunhiraman P.C

DIET Ernakulam

Rakesh

Neyyar Dam, Thiruvananthapuram

Paulose M.K

Govt. HSS, Perumbavoor, Ernakulam

Harikumar K.B

Kazhakoottam, Thiruvananthapuram

Hari Charutha

Nemam, Thiruvananthapuram

Hassan K.M

GHS Pezhakkappilli, Ernakulam

Academic Co-ordinator

Dr. Lidson Raj. J

Research Officer, SCERT

ENGLISH VERSION

Venugopal C.

*Asst. Professor, Govt. College of Teacher
Education, Thiruvananthapuram*

S. Bindu

*Asst. Professor of English (Retd)
University College, Thiruvananthapuram*

Academic Co-ordinator

Arun Jyothi. S. Research Officer, SCERT



State Council Of Educational Research and Training (SCERT)
Vidya Bhavan, Poojappura, Thiruvananthapuram - 695012



Contents

1. Hundred and above07

2. We can Add21

3. Let's Take Away33

4. When Shapes Join47

5. If Alike Joins63

6. Time75

**Certain icons are used in this
textbook for convenience**



**Additional activity/
Extended activity**



How I found out



How my friends found out



Assessment

1

Hundred and above

Hundredth Anniversary

Athira's school was set up 99 years ago.

The school is going to celebrate its hundredth anniversary next year.

Boxes to collect donations for the school were given to every student.

After a few days Athira opened her box.

All the coins in the box were 1 rupee coins.

Athira arranged the coins in the box in groups of ten.

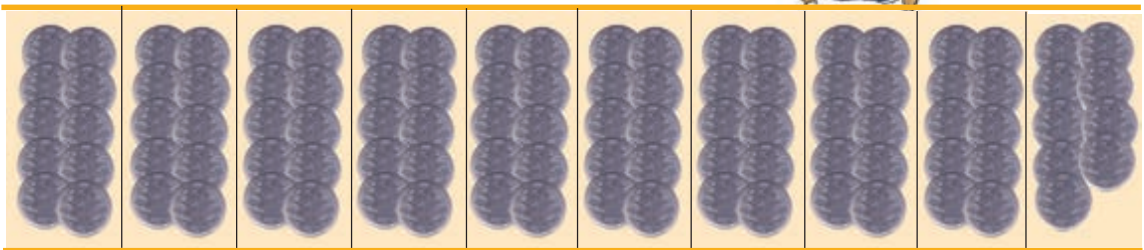

How many groups of ten could she make?

How many coins were there altogether?

Athira's mother gave her one more 1 rupee coin.

Now, what is the total number of 1 rupee coins?

Athira gave the coins to a shop and exchanged it for notes.

All the notes that the shopkeeper gave Athira were 10 rupee notes.

How many 10 rupee notes did she get?

To make 100, where should I put the bead?

Hundred	Ten	One
	10	10

Types of notes

In how many ways can hundred one rupee coins be changed to notes?

If all the notes are 50 rupee notes, then how many notes will be there ?



Can you complete it?

Athira's father gave her a hundred rupee note.

Athira had a 1 rupee coin with her.

When 1 was added to 100, it became 101.



That is $100 + 1 = 101$

Can you complete the table?

		$100 + 1 = 101$
		$100 + 2 = 102$
		$100 + 3 = 103$
		
		
		
		
		
		
		$100 + 10 = 110$

Ten Hundreds

For the hundredth anniversary celebration, 10 students contributed rupees 100 each. The table below shows the money given by them. Fill it.

	100	
	200	
	300	Three Hundred
4 Hundred	400	
5 Hundred		Five Hundred
6 Hundred		
	700	
	800	Eight Hundred
9 Hundred		Nine Hundred
	1000	

10 Hundreds is equal to Thousand



Let us plant saplings

As part of the anniversary celebrations, 100 saplings are to be planted around the school. How many saplings each can be planted?

Sapling	What I have found out	What the group found out		
Gooseberry				
Tamarind				
Mango tree				
Jack fruit tree				
Mahogany				
Neem				
Guava				
Drum stick tree				
Sapota tree				
Almond tree				

Book number

Students collected books for the school library.

The books collected on the first day are shown below. Can you number the books in order?

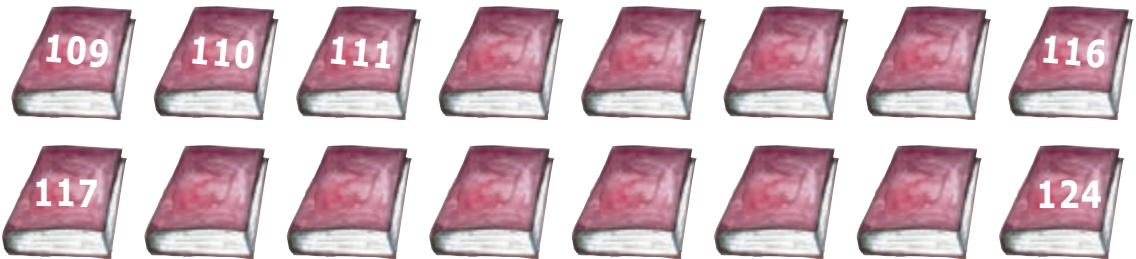

On the second day, the students collected 34 books. Then what is the number of the last book?

The books collected on the fifth day were numbered from 253 to 256. How many books were collected on the 5th day?

How many numbers?

How many numbers are there from 421 to 430?

How many numbers are there from 567 to 573?

How many numbers are there from 890 to 898?

.....

.....

The method I used to find out the numbers between one number and another

Maths Camp

A Maths Camp is to be organized in the school. The camp may be decorated with number chain. Complete the number chain given below.

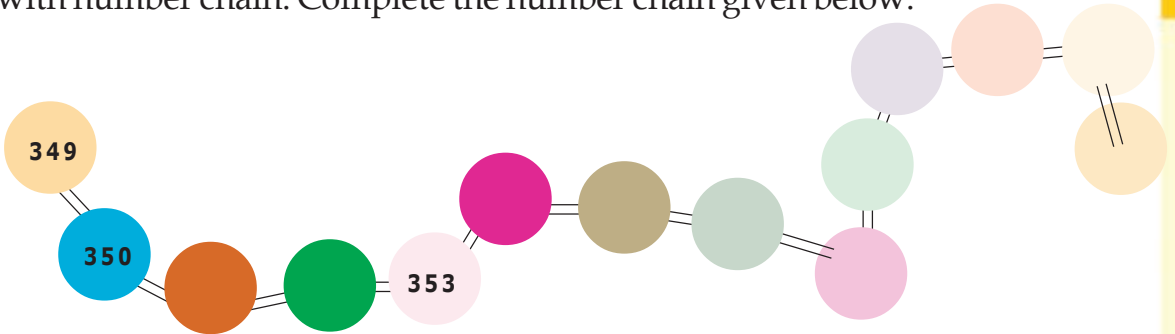

Students in the camp were given number badges.

Athira's badge number was 148.

Salim got his badge before Athira and Annie got her badge after Athira. What are their badge numbers?

Salim Annie

What is the badge number that was after Annie?

Badges were given to 20 students after Athira. What is the number of the last badge given?



Fill the boxes with numbers

828	829	830
	268	
318	319	
189		191
758		
	673	
		410

How did you find out the numbers in the empty boxes?

Donation

The amount collected last week as donation is given in the table below. Fill the empty boxes.

Sl. No.	Day	Total amount	
		in figures	in words
1	Sunday	775	Seven hundred and seventy five
2	Monday	501	
3	Tuesday	450	
4	Wednesday		Eight hundred and ninety nine
5	Thursday	900	Nine hundred
6	Friday		Three hundred and seventeen
7	Saturday	925	



Notes and Coins

What are the coins and notes in the amount collected on Sunday?

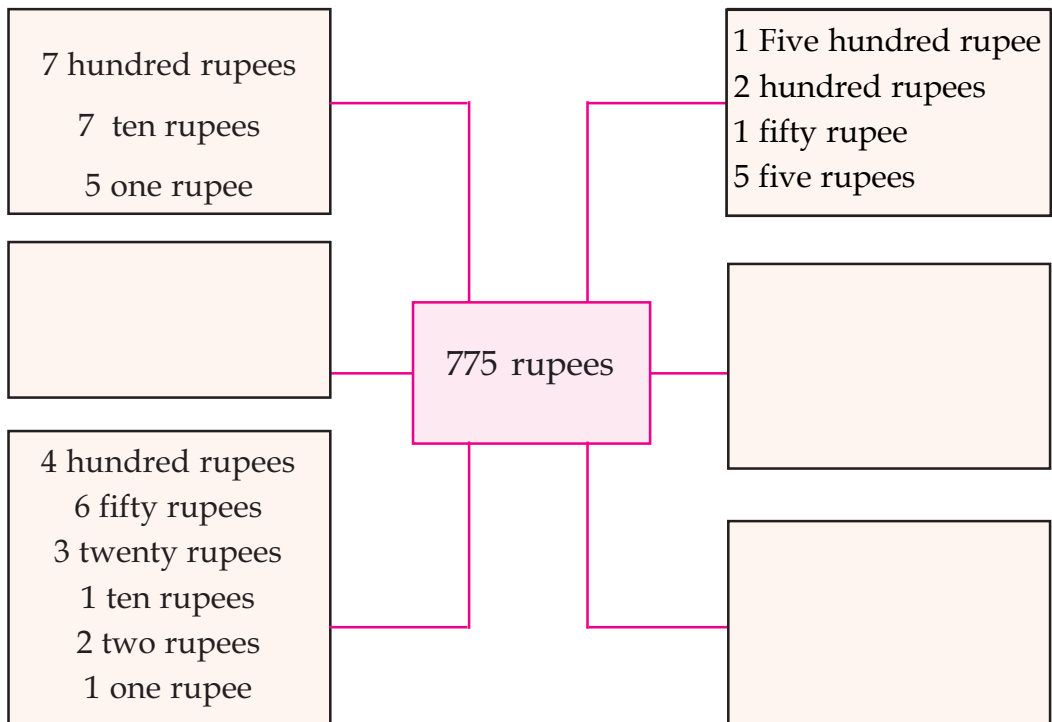

Now write the amount collected on Monday and Tuesday as coins and notes in different ways.

Write in table





Amount	Number of notes/ coins								Total amount
	500	100	50	20	10	5	2	1	
899	1	3	1	1	1	2	4	1	$500 + 300 + 50 + 20 + 10 + 10 + 8 + 1$

Write the amounts collected on Thursday, Friday and Saturday in the table given above.

Fill in the boxes

5 hundreds 2 tens 4 ones	524
	632
$700 + 90 + 8$	
9 hundreds 5 ones	
	859
	470

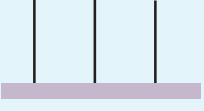
Arrange in the Abacus

	214
	132
	
	520
	
	600

Smaller? Larger?

375

246

742

596

357

593

Which is the smallest number among those given above?

Which is the largest number?

Arrange the numbers from larger to smaller.

How did you do it? Explain.

How much less?

Teacher asked to write a number with 6 hundreds and 4 tens. But Sunanda wrote the number with 4 hundreds and 6 tens. What is the difference between the original number and the number written by Sunanda?

Classify and arrange

Students classified the books collected in a day.

Look at the numbers given to the books in each section.

Can you arrange them?

Travel books

324, 432, 234, 329, 502, 243

Mathematics books

372, 405, 198, 350, 218, 281, 179

Science books

340, 202, 153, 418, 147, 390, 284, 189



Small or Big?



Use the digits given above to form 3 digit numbers.

You can use one digit only once in a 3 digit number.



Which is the smallest number?

Which is the largest one?

Can you write the 3 digit numbers in the ascending order?

Look at the digit in the 100th place of the smallest and largest numbers.

What is their speciality?

What about the digit in the one's place?

- Now use the digits 4, 5 and 0 to form as many 3 digit numbers as possible. Write them in the descending order.

Without repeating any of these numbers, how many 2 digit numbers can be written?



Do not begin with zero

Number of notes

Sunir has 754 rupees with him. The number of notes and the sum of the digits are equal. What are the notes with Sunir?

Count the chalks

The children counted the chalks they made.

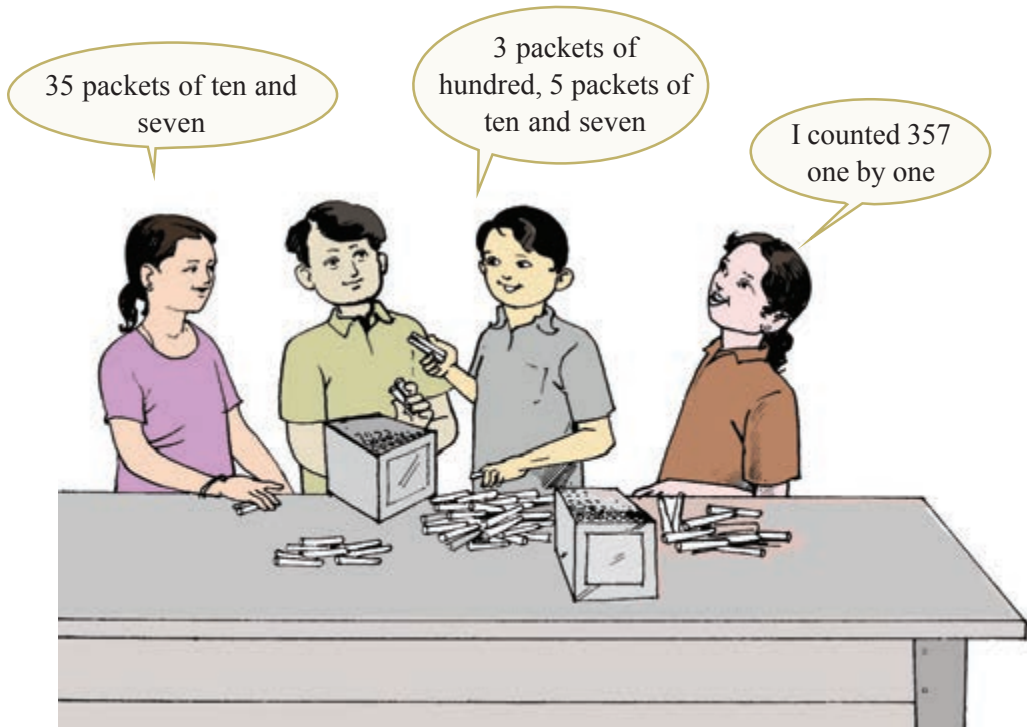

All got 357.

Look at the picture below.

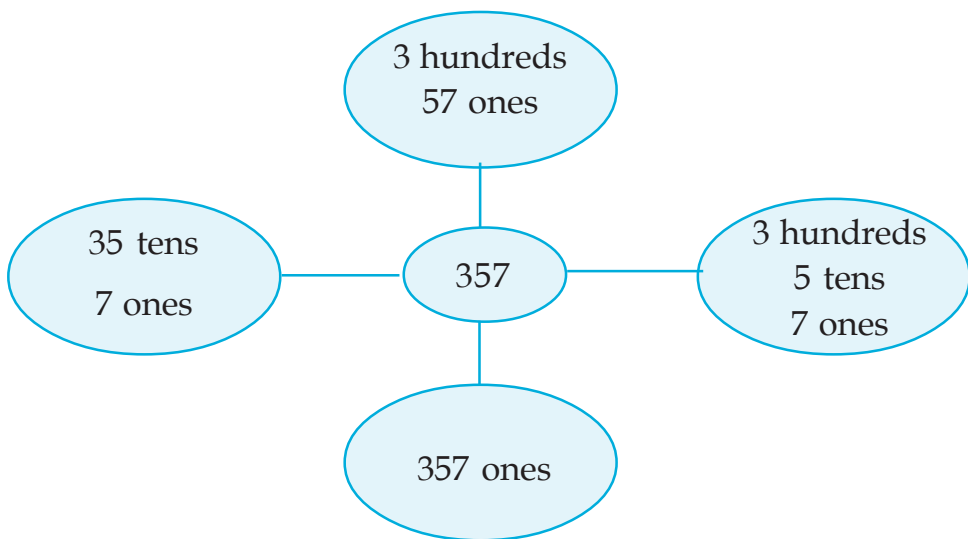

Write these numbers also in the same way.

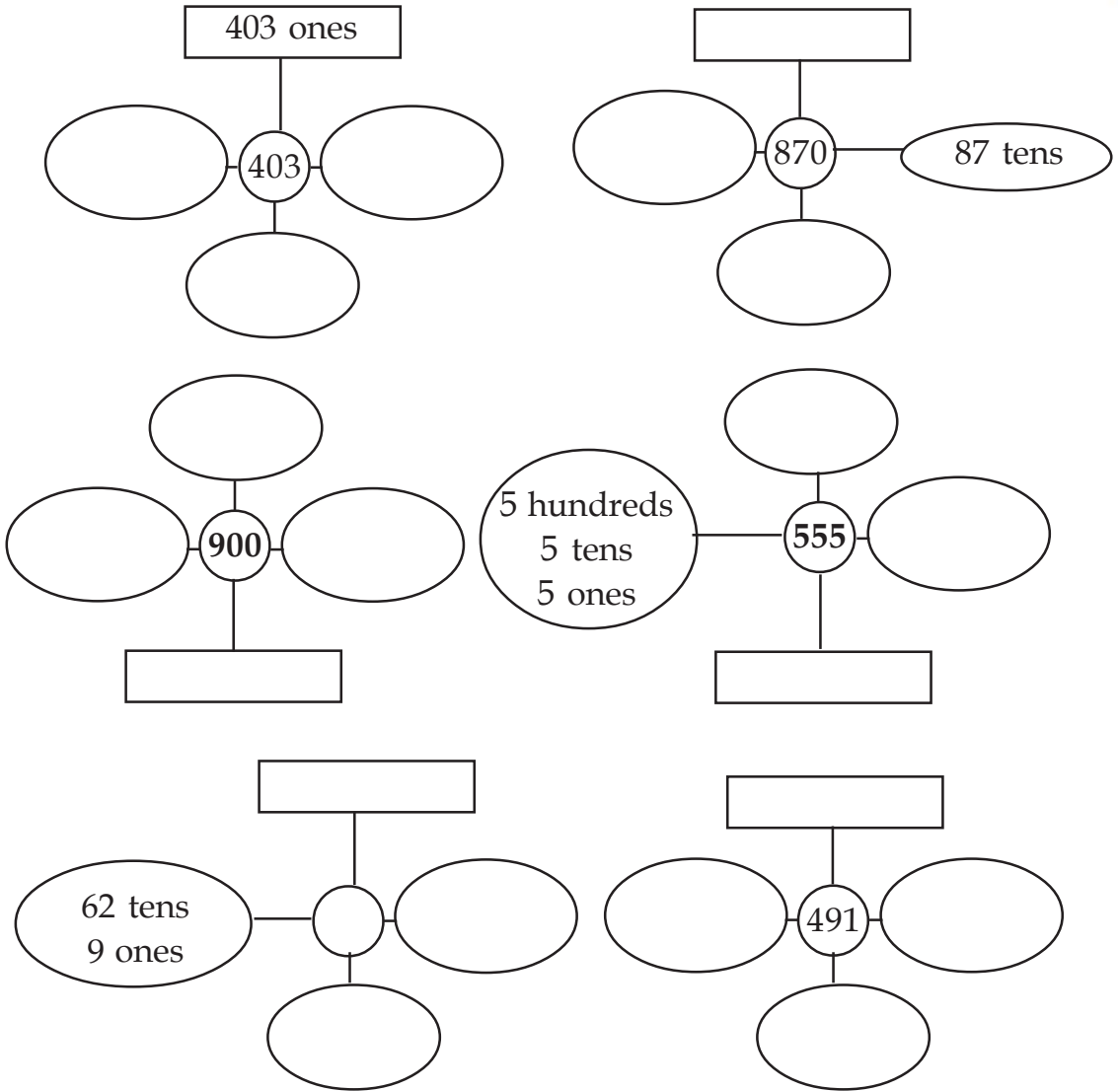

Big Number

Name of the player	Number		

5 children can play this. First player throws the dice. The number in the dice can be written in any box. Then the others throw the dice. When all the boxes are filled, the person who gets the biggest 3 digit number wins. Now, play this game with your friends.

Complete the pattern

- 330, 340, 350, , ,
- 575, 600, 625, , ,
- 950, 900, 850, , ,
- 412, 512, 612, , ,
- 203, 313, 423, , ,

Cost of the bag

Athira's father bought her a bag. He gave the shopkeeper 2 hundred rupee notes, 17 ten rupee notes and 13 one rupee coins. What is the cost of the bag?

Which Note?

Athira and her friend Ramla went to the shop with a note each.

When Athira changed her note, she got 2 hundred rupee notes, 3 fifty rupee notes, 5 ten rupee notes and 20 five rupee notes.

Ramla bought things for 50 rupees. She got 2 hundred rupee notes, 4 fifty rupee notes and 5 ten rupee notes as balance.

What is the note they had in the beginning?

In which ways can you arrange notes and coins to get 500 rupees?

How I found out



How my friends found out



50 Rupee note

Raju gave 8 hundred rupee notes and in return got 50 rupee notes. How many 50 rupee notes did he get? If he got it back in 20 rupee notes, how many 20 rupee notes would be there?

Giving numbers

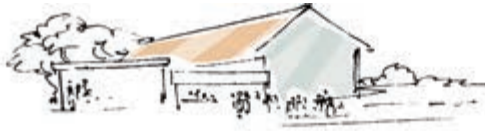

Numbers are given to students participating in sports events. Students of LP section were given numbers from 201 to 265. Students of the UP section were given numbers from 266 to 340. From which section did the maximum number of students participate?

Can you make the sum 12 ?

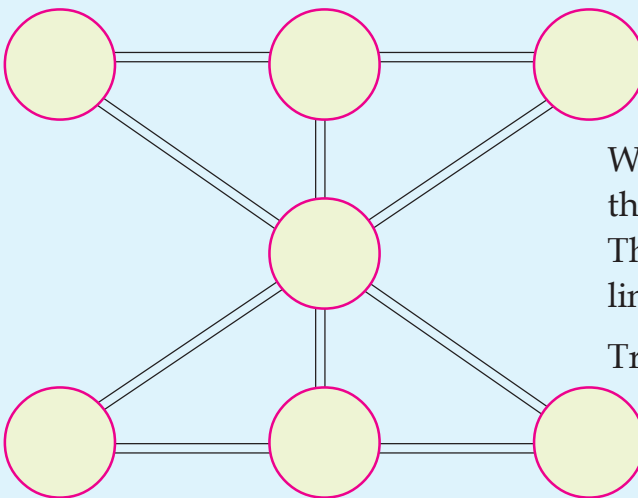

Write numbers from 1 to 7 in the circles without repeating. The sum of the numbers in a line should be 12.

Try to complete it.

Fill the boxes

100	200	300
300	100	200
200	300	100

	400	

- Look at the numbers in the first box. What are the numbers in each row?
- Now use the numbers 400, 500 and 600 to fill the second box. Use the numbers 700, 800 and 900 to fill the third box.
- When we keep the boxes together, what are the numbers in the first row?
- Are these numbers present in the second and third rows?

Across and Down

90	140	190
100	150	200
110	160	210
300	450	600			

- There is a pattern for the numbers in the box. Fill the box according to this pattern.

Let us add

$$\begin{array}{r}
 1 \ 2 \ 3 \ 4 \ 5 \ 6 \ 7 \ 8 \ 9 \ + \\
 9 \ 8 \ 7 \ 6 \ 5 \ 4 \ 3 \ 2 \ 1 \\
 \hline
 1 \ 1 \ 1 \ 1 \ 1 \ 1 \ 1 \ 1 \ 1
 \end{array}$$

$$\begin{array}{r}
 1 \ 2 \ 3 \ 4 \ 5 \ 6 \ 7 \ 8 \ 9 \ + \\
 9 \ 8 \ 7 \ 6 \ 5 \ 4 \ 3 \ 2 \ 1 \\
 1 \ 2 \ 3 \ 4 \ 5 \ 6 \ 7 \ 8 \ 9 \\
 9 \ 8 \ 7 \ 6 \ 5 \ 4 \ 3 \ 2 \ 1 \\
 \hline
 2 \ 2 \ 2 \ 2 \ 2 \ 2 \ 2 \ 2 \ 2
 \end{array}$$

- What about the next pattern.

2

We can Add

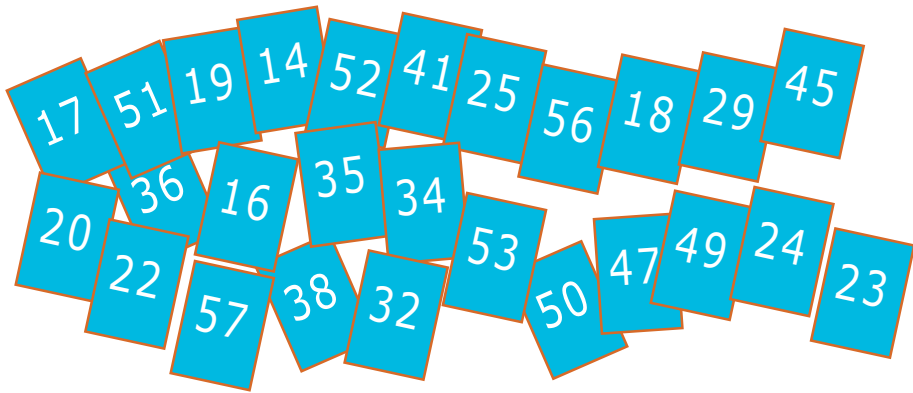

How many pairs?

- Unni and Tommy are playing number cards.
- The sum of the two cards should be 70.
- One who makes the most pairs will win.
- Now try to get 70 by adding the numbers in two cards.
- How many such pairs did you get?

How we found out

-
-
-
-
-

My thought

Tommy and his mother went to the shop.
 They bought fruits for 100 rupees.
 How did Tommy think of giving the money?

$$56 + 44 = 56 + 40 + 4 = 100$$

$$56 + 44 = 50 + 6 + 40 + 4 = 100$$

$$\dots\dots\dots = \dots\dots\dots = \dots\dots\dots$$

$$\dots\dots\dots = \dots\dots\dots = \dots\dots\dots$$

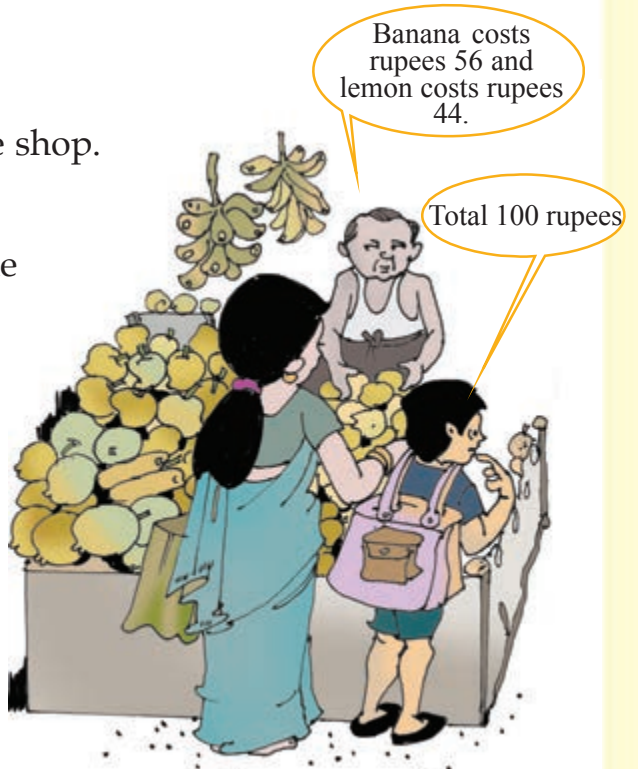

- Ammu bought 2 kilograms of sugar and 2 kilograms of dal from the shop. Cost of 1 kilogram of sugar is rupees 35 and dal is rupees 68. How much money did she pay?

Rows and Columns

Add together the numbers horizontally, vertically and diagonally. Do you see any peculiarity in the sum?

Try to make a similar one with 9 consecutive numbers.

Have you got a magic square?

128	121	126
123	125	127
124	129	122

Look at the Bill









Tommy and Mary went to the shop to buy some grocery and vegetables.



Number 228 Grocer's shop		
Item	Weight	Amount
Rice	5 kg	150
Sugar	2 kg	56
Soap	2 kg	20
Total	

Number 136 Vegetable shop		
Item	Weight	Amount
Onion	1 kg	25
Lady's finger	1 kg	25
Carrot	1 kg	36
Banana	1 kg	50
Total	

What is the amount in each bill? What is the total amount?

<p>Bill from the grocery shop</p>	 <p>2</p>	 <p>2</p>	 <p>6</p>
<p>Bill from the vegetable shop</p>			
<p>Total</p>	 <p>3 hundreds</p>	 <p>5 tens</p>	 <p>12 ones</p>

Changed 12 one rupee into a ten rupee and 2 one rupees. We can add a ten rupee with 5 ten rupees.

3 hundreds	5 tens	12 ones
3 hundreds	6 tens	2 ones

We can write this as

hundreds	tens	ones
2	2	6
1	3	6
3	6	2

$$\begin{array}{r}
 1 \\
 226 + \\
 136 \\
 \hline
 362
 \end{array}$$

Birthday Gift

Mary and Tommy opened their savings box to buy a birthday gift for their father.

There is 354 rupees in my box and rupees 172 in his box.

Let us go in the evening to buy the gift.



What is the total amount of their savings ?

12 tens means 10 tens and 2 tens.

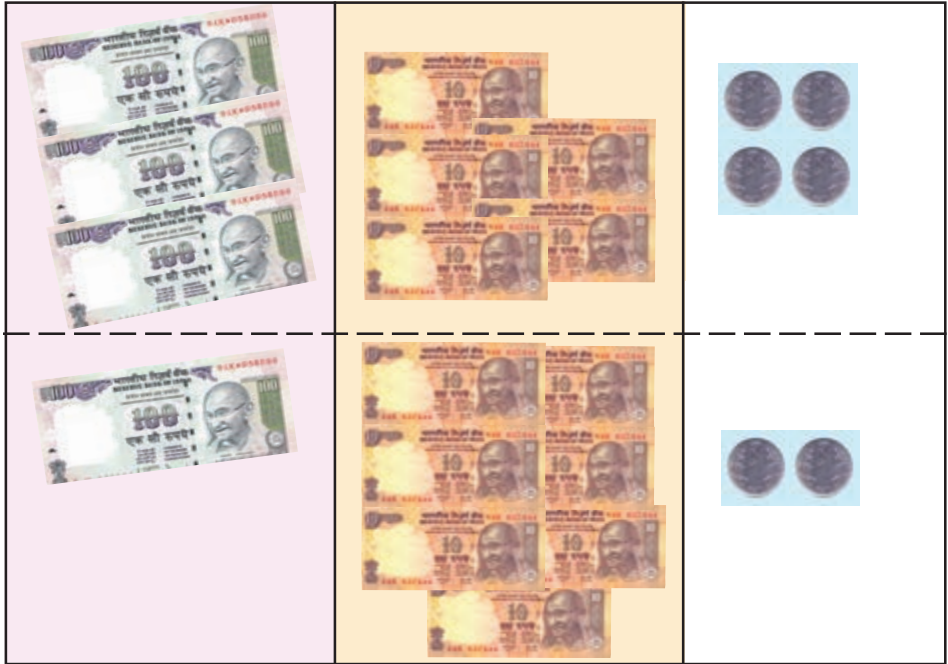

3 hundreds 5 tens 4 ones +

1 hundred 7 tens 2 ones

①
4 hundreds ① 2 tens 6 ones

We can write this as

hundreds	tens	ones
3	5	4
1	7	2
5	2	6

$$\begin{array}{r}
 1 \\
 354 + \\
 172 \\
 \hline
 526 \\
 \hline
 \end{array}$$

Library

Mary's school library has 524 Malayalam books and 75 English books.

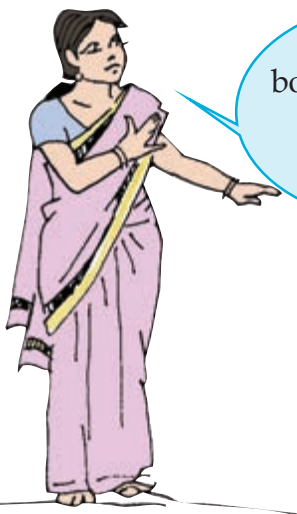

Out of the 120 books that arrived today, 20 are English books

- What is the total number of books in the library including the new arrivals?
What is the total number of English books?
What about Malayalam books?

Sports Meet

In the sub-district sports meet conducted at Mary's school, 199 boys and 204 girls participated on the first day. On the second day, 31 other boys and 21 other girls also participated.

- How many students participated in the sports meet altogether?
- Who are more in number, girls or boys?
- Students who participated in the race, were given chest numbers from 951 to 989. If so, how many took part in the race?



How I found out



How my friends found out



The Beauty of numbers

Using three consecutive digits from 1 to 5, write the largest and the smallest numbers. Find their sum. What is the peculiarity of the sum?

Find out.

How many groups?

As part of the sports meet, 269 coconuts were received from the LP section to make *payasam*. However, 162 more coconuts were received from the UP section than from the LP.

- How many coconuts were there altogether?
- If all the coconuts are arranged in groups of 100, what will be the number of groups?



I understood how to find the total

Without knowing the number in the UP section, I can find the total

I am sure that the method I used is correct

I can say the method and operation by which I reached the answer

Victory celebration

Look at the points received by each group in the school sports meet.

We have 70 points
in group items and 180
points in individual items.



We have 60 points
in group items and 190
points in individual items.



Find the total points of each group Who got more?

Circus

Everyone was eager to see the circus.

Today tickets were
given to 765 gents, 348
ladies and 92 kids.



Find the total number of people who bought the tickets.

Colour it

Somebody is hiding in this picture. Find the sum of the numbers given below. Colour the parts having these numbers.

$$\begin{array}{r} 345 + \\ \hline 543 \\ \hline \end{array}$$

.....

$$\begin{array}{r} 740 + \\ \hline 360 \\ \hline \end{array}$$

.....

$$\begin{array}{r} 580 + \\ \hline 406 \\ \hline \end{array}$$

.....

$$\begin{array}{r} 529 + \\ \hline 382 \\ \hline \end{array}$$

.....

$$\begin{array}{r} 567 + \\ \hline 765 \\ \hline \end{array}$$

.....

$$\begin{array}{r} 606 + \\ \hline 205 \\ \hline \end{array}$$

.....

$$\begin{array}{r} 340 + \\ \hline 286 \\ \hline \end{array}$$

.....

$$\begin{array}{r} 457 + \\ \hline 308 \\ \hline \end{array}$$

.....

$$\begin{array}{r} 409 + \\ \hline 235 \\ \hline \end{array}$$

.....

$$\begin{array}{r} 393 + \\ \hline 139 \\ \hline \end{array}$$

.....

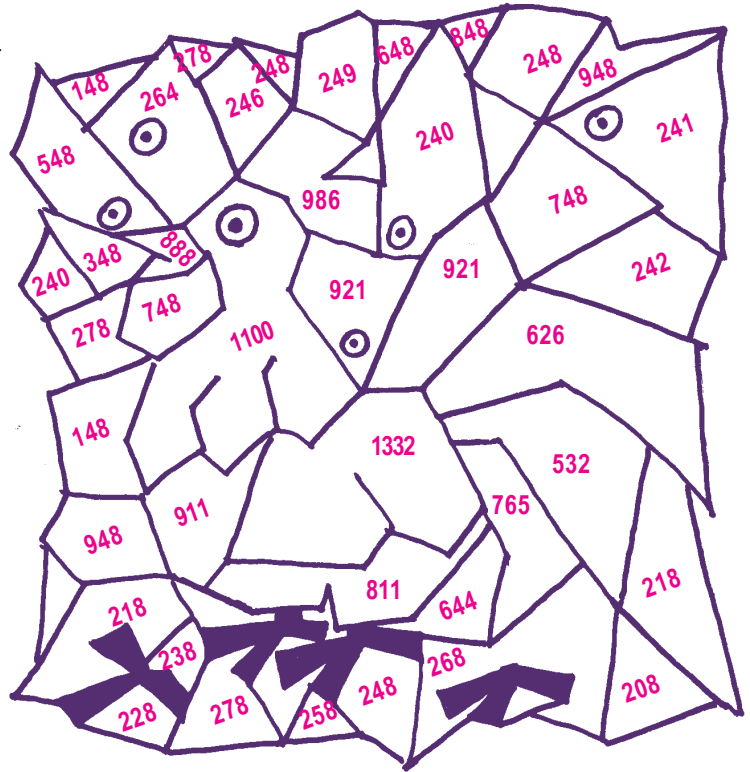

Win a prize

Look at the advertisement of a textile shop.

- Sini bought a saree and a shirt.
- Sanitha purchased a churidar, a saree and a bag.
- Rasiya bought a bag and an umbrella.
- Rasheed bought a baniyan, a shirt and an umbrella.
- Laila bought a skirt and a top.
- Ancy purchased a saree.

Who all will get the gift coupon?

Baniyan	76 rupees
Shirt	325 rupees
Churidar	350 rupees
Skirt	265 rupees
Top	215 rupees
Umbrella	175 rupees
Bag	285 rupees
Saree	375 rupees

Note : Gift coupons for those who buy things for over 500 rupees.



- In a plantain grove, 874 saplings were planted on the first day and 569 on the second day. What is the total number of saplings planted?
- A wholesale dealer distributed 666 bags of rice on the first day, 555 bags on the second day and 777 bags on the third day. Find the total number of bags distributed on the three days.
- For a relief fund, 468 rupees was received on the first day and 357 rupees on the second day. What is the total amount collected in the first two days? To make it 1000, how much more is needed?
- To see the Maths fair, 228 people came on the first day and 272 on the second day. On the final day double the number of people of the two previous days came. Then what is the total number of visitors to the fair?
- For a study tour, 6 buses having 40 seats each were arranged. In the last bus, half the seats were empty. Find the total number of students who went for the tour?

Odd or Even

Sum of two consecutive numbers

$$1 + 2 = \dots\dots\dots$$

$$2 + 3 = \dots\dots\dots$$

$$\dots\dots + \dots\dots = \dots\dots\dots$$

$$9 + 10 = \dots\dots\dots$$

$$22 + 23 = \dots\dots\dots$$

$$131 + 132 = \dots\dots\dots$$

$$\dots\dots + \dots\dots = \dots\dots\dots$$

$$\dots\dots + \dots\dots = \dots\dots\dots$$

What is the peculiarity of the sum of two consecutive numbers? Why?

The sum of two consecutive numbers is always an odd number.

Find the sum of two even numbers.

$$2 + 4 = \dots\dots\dots$$

$$4 + 6 = \dots\dots\dots$$

$$6 + 10 = \dots\dots\dots$$

$$\dots\dots + \dots\dots = \dots\dots\dots$$

$$14 + 16 = \dots\dots\dots$$

$$28 + 40 = \dots\dots\dots$$

$$246 + 268 = \dots\dots\dots$$

$$\dots\dots + \dots\dots = \dots\dots\dots$$

$$\dots\dots + \dots\dots = \dots\dots\dots$$

What is the peculiarity of the sum of two even numbers? Why?

- In the school PTA meeting, 107 men and 270 women participated. Find the total number of persons who attended the meeting.
- Village Club, under the project 'A hen to a student' distributed chicks to all the students in the school free of cost. On the first day 384 chicken were distributed and on the second day 448. Then what is the total number of students in that school?

Find the sum of the two odd numbers.

$$3 + 5 = \dots\dots\dots$$

$$5 + 7 = \dots\dots\dots$$

$$\dots + \dots = \dots\dots\dots$$

$$13 + 17 = \dots\dots\dots$$

$$127 + 139 = \dots\dots\dots$$

$$\dots + \dots = \dots\dots\dots$$

$$\dots + \dots = \dots\dots\dots$$

What is the peculiarity of the sum of two odd numbers?

What is the sum of an odd number and an even number ?

Can you find the way

Chakki cat is trying to catch Chindan mouse. The cat can catch the mouse only if he goes in the right path. Can you help the cat?

To find the way cat has to jump from the first box to the box having double the number of the first box. Again jump to the box with double the number.



1	2	4	8	16	18
5	4	6	42	14	36
10	8	16	32	64	72
20	88	32	126	456	48
40	36	64	128	256	512
80	100	128	500	1000	1024



- Abu bought vegetables for rupees 445 and sold it for rupees 600. Fruits were purchased for rupees 415 and were sold for rupees 600.

For purchasing these items how much did Abu pay?

What is the total amount Abu got after the sale?

Write the next numbers

• 10,	30,	50,	70,
• 120,	140,	160,	180,
• 555,	565,	575,	585,
• 225,	250,	275,	300,
• 100,	110,	130,	160,

Add these

Arrange to get the sum 450 when it is added row wise and column wise.

10 + 20 + 30 + 40 + 50 + 60 + 70 + 80 + 90	=	450
20 + 40 + 70 + 90 + 10 + 50 + 80 + 30 + 60	=	450
30 + 90 + + + + + + + + +	=
40 + 10 + + + + + + + + +	=
50 + 60 + + + + + + + + +	=
60 + 70 + + + + + + + + +	=
70 + 80 + + + + + + + + +	=
80 + 50 + + + + + + + + +	=
90 + 30 + + + + + + + + +	=
450	450	

Numbers and Numbers

5	4	3	2	1	+	1	2	3	4	5	+
	4	3	2	1		1	2	3	4		
		3	2	1		1	2	3			
			2	1		1	2				
				1		1					
<hr/>											
5	8	9	8	5		1					

2	4	6	8	+	8	6	4	2	+
2	4	6				6	4	2	
2	4						4	2	
2								2	
<hr/>									
9	3	2	8						

3

Let's Take Away

To the store

This is the store run by the students of a Govt. UP School.

- Read the stock board of the store.
- Find the stock of each item.
- What about today's sale?



Stock Board		
Cost	item	stock
10	Note book	100
6	Pen	50
3	Pen Pencil	75

Today's sale is 25 note books, 15 pens and 20 pencils.

What is the balance stock after today's sale?

- How did you find it?

How I found out



Note book	
Pen	
Pencil	

- Next day 72 note books, 100 pens and 125 pencils were added. Find the total stock of each item now.

We need 25 note books, 24 pens and 29 pencils for our class.



- Ammu bought these items from the store. Find the balance of each item in the store.

■ How did you find it?

How I found out



Science Magazine

I paid rupees 156 from rupees 175 given to me by my father.



How my friends found out

It's not possible to take away 6 rupees from 5.

■ What is the balance with Ammu?

- How did you find it?



■ Rupees 175 means $100 + 70 + 5$



■ Rupees 156 means $100 + 50 + 6$



- If one ten rupee is taken from seven ten rupees and then added to rupees 5, what do we get?

$$\begin{array}{r}
 100 + 60 + 15 - \\
 100 + 50 + 6 \\
 \hline \\
 \hline
 \end{array}$$

We can write this as

Hundreds	Tens	Ones
1	7	5
1	5	6

-

Hundreds	Tens	Ones
1	6	15
1	5	6
0	1	9

-

$$\begin{array}{r}
 6 \\
 1 \quad 7 \quad 15 - \\
 1 \quad 5 \quad 6 \\
 \hline
 1 \quad 9
 \end{array}$$

Scholarship Fund

All the students in Ammu's class donated to the school's scholarship fund.

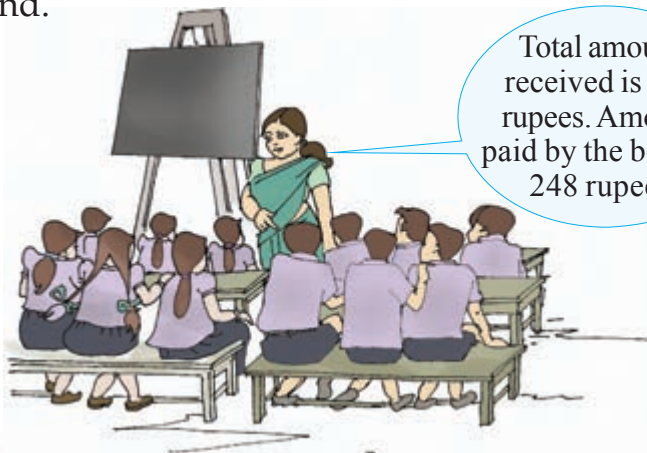

Total amount received is 436 rupees. Amount paid by the boys is 248 rupees

- What is the amount paid by the girls?

- How did you find it?
 - Subtract 248 from 436.
- What is the way?

We can't take away 8 rupees from 6 rupees and 4 ten rupees from 3 ten rupees.



3 ten rupees in 436 rupees. We can add 1 ten rupee with 6 rupees

$$\begin{array}{r} 400 + 30 + 6 - \\ 200 + 40 + 8 \end{array} \longrightarrow \begin{array}{r} 400 + 20 + 16 - \\ 200 + 40 + 8 \end{array}$$

Next 4 tens from 2 tens. There are 4 hundred rupees. Change one hundred into tens



Then we can write it this way

$$\begin{array}{r} 300 + 120 + 16 - \\ 200 + 40 + 8 \end{array}$$

That is,

$$\begin{array}{r} 400 + 30 + 6 - \\ 200 + 40 + 8 \end{array} \longrightarrow \begin{array}{r} 400 + 20 + 16 - \\ 200 + 40 + 8 \end{array} \longrightarrow \begin{array}{r} 300 + 120 + 16 - \\ 200 + 40 + 8 \\ \hline 100 + 80 + 8 \end{array}$$

We can shorten these steps like this.

Hundreds	Tens	Ones
4	2 3	6
2	4	8

Hundreds	Tens	Ones
3 4	2	16
2	4	8

Hundreds	Tens	Ones
3	12	16
2	4	8
1	8	8

In short, we can write

$$\begin{array}{r}
 12 \\
 3 \ 4 \ 3 \ 6 \ - \\
 2 \ 4 \ 8 \\
 \hline
 1 \ 8 \ 8
 \end{array}$$

$$\begin{array}{r}
 436 \ - \\
 248 \\
 \hline
 188
 \end{array}$$

To find if this is correct

$$\begin{array}{r}
 436 \ - \\
 248 \\
 \hline
 188
 \end{array}$$

look at this

$$\begin{array}{r}
 188 \ + \\
 248 \\
 \hline
 436
 \end{array}$$

It is correct!



- Mother has 4 hundred rupee notes and 5 ten rupee notes with her. She gave 120 rupees to Anu. What is left with Anu's mother now? What are the notes with her?

Story Book

- Ammu bought a story book from the store.



I had rupees 750. Now I have only rupees 505



What should be added to 505 to make 750?



Instead of 505 what if it is 500 ?



■ What is the cost of Ammu's story book?

- Ammu gave 250 rupees to her mother. She bought a hand bag.

■ What remains with Ammu?

In the Bank

There was 952 rupees in the account. Now it is only 227.

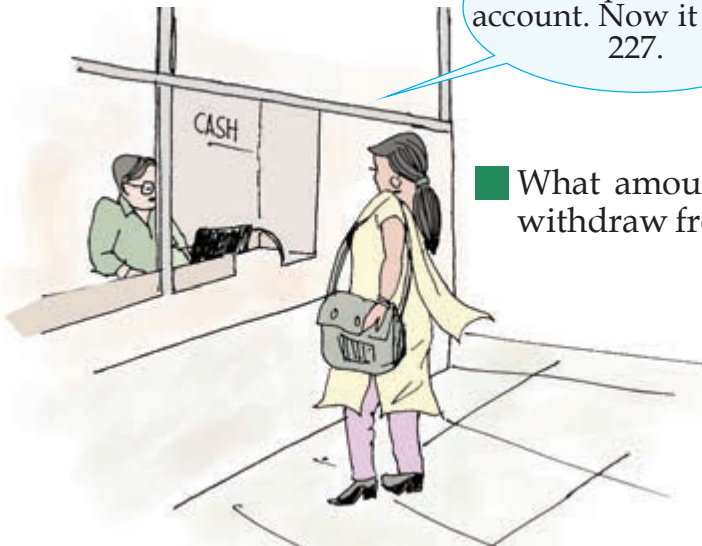

■ What amount did Ammu's mother withdraw from the Bank?

In the rice shop

Ammu's father went to the store to purchase rice.



25 kg rice costs rupees 900. I have only rupees 763 with me.

■ Ammu's brother gave him the balance amount.

What amount did her brother give?

How I found out



How my friends found out



Cricket

Ammu is watching cricket.

Oh! It is raining. India could score 160 runs and Sri Lanka scored 250 runs

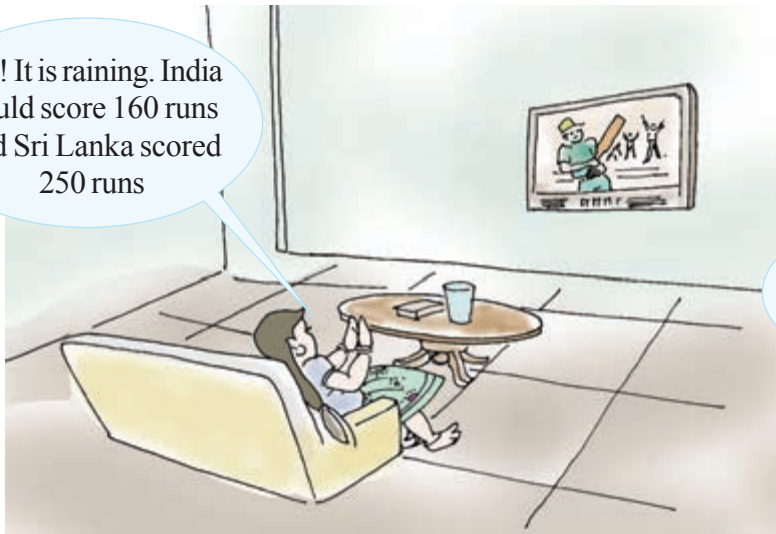

How many runs more does India need to reach Sri Lanka's score?

If we subtract 16 tens from 25 tens, what will we get?



■ How did you find it?

How I found out



How my friends found out



In a one day cricket match, India scored 243 runs. The opposite team could score only 193 runs. How many more runs did India score?

To the school

Vegetable seeds were brought from the "Krishi Bhavan" for distribution.

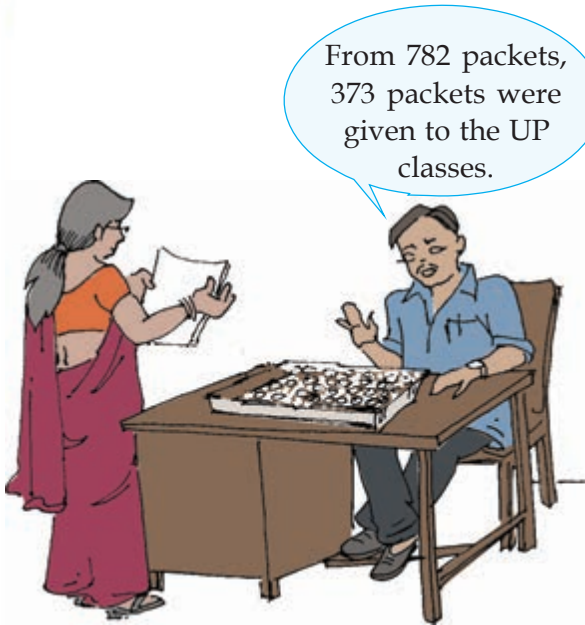

■ How many packets are left?

■ From the remaining, if 329 packets are given to 2, 3, 4, 5 classes, what will be left for class I?



Of the 686 grains that the tiny ant collected, he gave 247 to the baby squirrel and 265 to the pretty parrot. How many grains are left with the tiny ant?

Mid day meal

Every day a nutritious meal is given to students in Ammu's School.

391 kg. of rice are needed for 5 days. After 3 days, 158 kg. of rice was left.

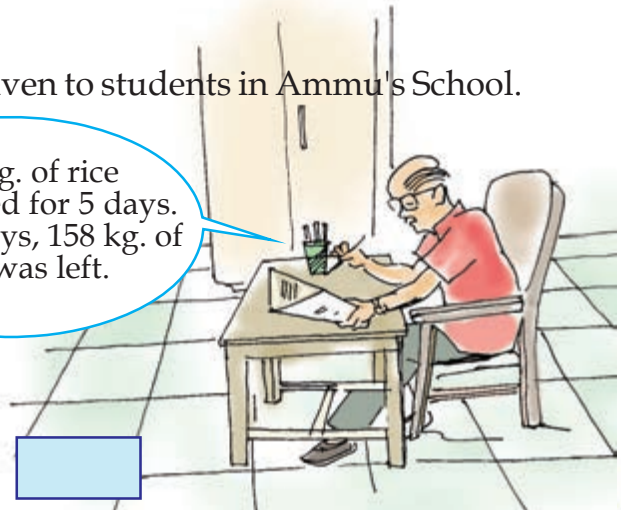

■ How many kilograms of rice was used in 3 days?

Grandma's age



What is difference in their ages?

Milk distribution



Today we got 536 litres of milk. After supplying to schools, 286 litres of milk was left. How many litres of milk were given to the schools?

What should be added to 286 to get 536?



- Can you help?



In the fruit shop, there were 325 apples in the morning. If there is 98 left, how many apples were sold?

Uniform

In a School, there is a stock of 167 metres of cloth for skirts and 118 metres of cloth for shirts. This year another 495 metres of skirt material and 345 metres of shirt material were added. After distribution, 178 metres of skirt material and 145 metres of shirt material were left. How much cloth was distributed this year?



■ How you can find out?

- Can you write it in a table?
- What all need to be written?
-
-

How I found out



How my friends found out



I know what I have to find out.

I found and wrote what was needed in the table.

I know that the operations I did were correct.

I understand that there are several other ways too.

Independence Day Rally

In the rally conducted by Scouts and Guides and the Red-Cross, 296 boys and 336 girls participated. Of this, 186 were Scouts and 177 were Guides. Then, how many were from Red - Cross?



How I found out



How my friends found out





To find, if this is correct, the way I used

Science Fair

A Science fair was conducted at Ammu's school.



On the first day 386 persons and on the second day 637 persons had food.



■ On which day did more persons take food? By how much?

■ 1000 chairs were hired for the Science Fair. Due to some reasons, 186 chairs were returned. Find the number of chairs used.



Subtract 1 from 1000. Then subtract 186 from the answer. And then add 1.

$$1000 - 1 = 999$$

$$999 - 186 = 813$$

$$813 + 1 = 814$$

$$1000 - 186 = 814$$

Subtract 1 from 1000.

Subtract 1 from 186. Subtract that answer from the first answer. Is this answer equal to the previous question ?

$$1000 - 1 = 999$$

$$186 - 1 = 185$$

$$999 - 185 = 814$$

Number Pyramid

Subtract the smaller number from the nearest big number and complete the number pyramid.

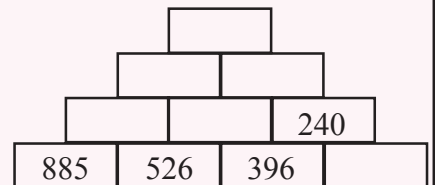



- Among the 240 notebooks with the School Society, half of them were sold. Find the number of notebooks left.
- Ramu bought brinjal for 545 rupees and lady's finger for 232 rupees. He sold the brinjal for 637 rupees and the lady's finger for 365 rupees. Find the profit from each sale. What was the total profit?
- Ammu bought some household things from Babu store for 903 rupees. Anu bought the same things from Maveli Store for 784 rupees. Which is the best purchase? By how much?
- PTA bought 840 laddus for the Independence Day celebrations. The number of students in the first standard is 89, second standard 93, third standard 87, fourth standard 98 and in the fifth standard 102.

If one laddu is given to each student, find the number of laddus left.

Find the number of laddus needed more to distribute two laddus each to every student.

- In a UP School, the number of students in the LP section is 292 and 345 in the UP section. Among them 349 are boys. Find the number of girls in the school. Who are more in number, boys or girls? By how much?

Rat and Cat

Kandan cat is running to catch Manian rat. Manian can escape through the wall around. One number noted on the wall is not the difference of the numbers given in the middle. Find the number and help him to escape through this.

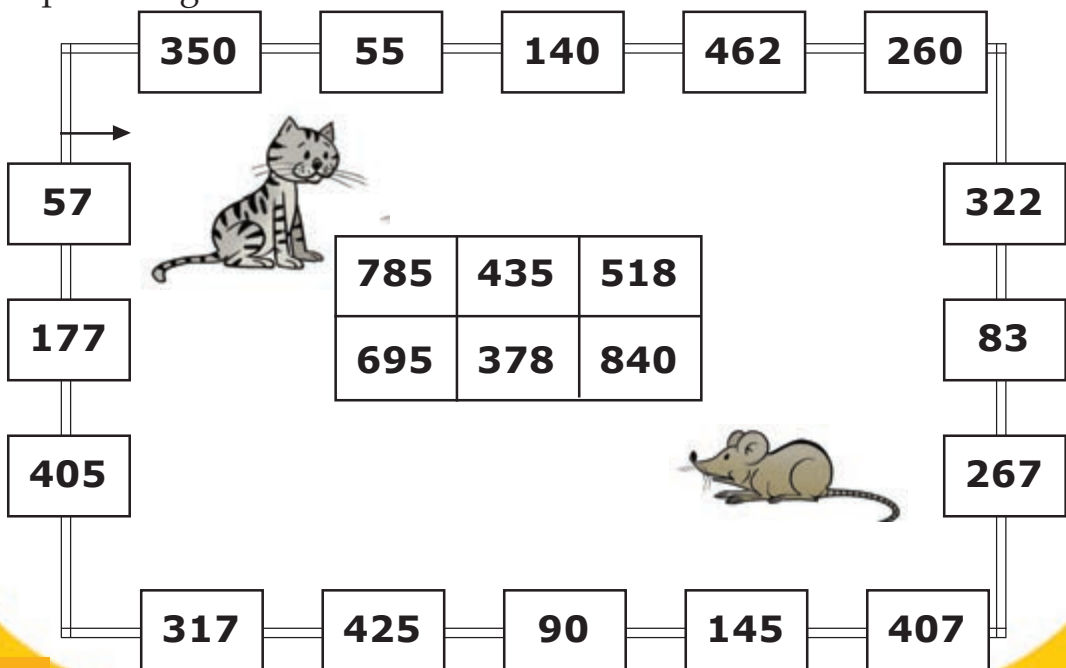

Write the difference

Write the numbers in the wheel to get the difference as the middle number.

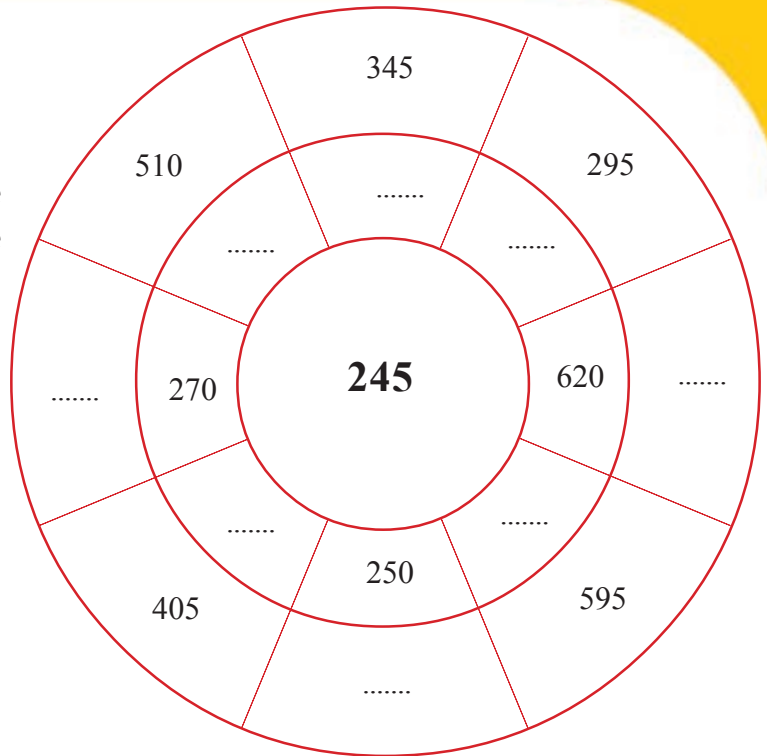

LOVE

0	1	2	3	4	5	6	7	8	9
O	L	D	L	A	D	Y	E	V	E

- Write a three digit number without repeating the digits and without zero.
- Write this number in the reverse order.
- Subtract the smaller number from the bigger one.
- Write the answer you got in the reverse order.
- Add this reversed number to the above answer.
- Try to write the letters according to the digits of the last number.

Complete the number pattern

1. 100, 90, 80,,,
2. 128, 64, 32,,,
3. 900, 800, 700,,,
4. 780, 680, 580,,,
5. 300, 250, 200,,,
6. 350, 290, 240,,,

Locks and Keys

It was found that the locks and their keys were interchanged. Answer the questions in the locks and keys. Then you can open them.

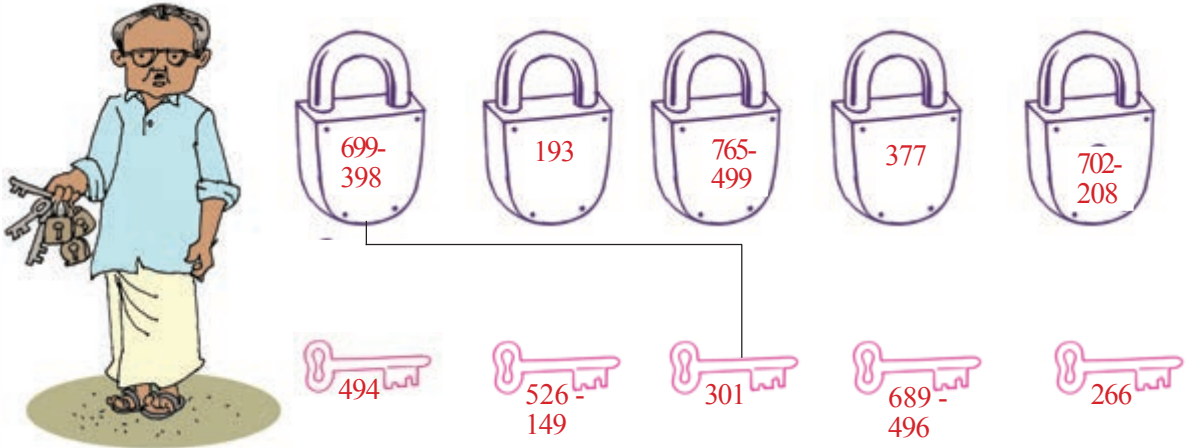

Nine and me

$$990 - 099 = 891$$

$$981 - 189 = 792$$

$$972 - 279 = 693$$

$$963 - 369 = 594$$

$$954 - 459 = 495$$

$$945 - 549 = 396$$

$$936 - 639 = 297$$

$$927 - 729 = 198$$

$$918 - 819 = 099$$

Find out the peculiarity

$$994 - 90 = 904$$

$$994 - 180 = 814$$

$$994 - 270 = 724$$

$$994 - 360 = 634$$

$$994 - 450 = 544$$

$$994 - 540 = 454$$

$$994 - 630 = 364$$

$$994 - 720 = 274$$

$$994 - 810 = 184$$

$$993 - 90 = 903$$

$$993 - 180 = 813$$

$$993 - 270 = 723$$

$$993 - 360 = 633$$

$$993 - 450 = 543$$

$$993 - 540 = 453$$

$$993 - 630 = 363$$

$$993 - 720 = 273$$

$$993 - 810 = 183$$

Prepare a similar one like the above.

4

When Shapes Join



Look at the picture.

Can you say what are the geometric shapes in the picture?

Which of them are rectangular in shape?

Circular shape?

Triangular shape?

Let's give colour

Look at Appu colouring.



Colour the pictures given below.

Give blue colour for triangles and red for rectangles.

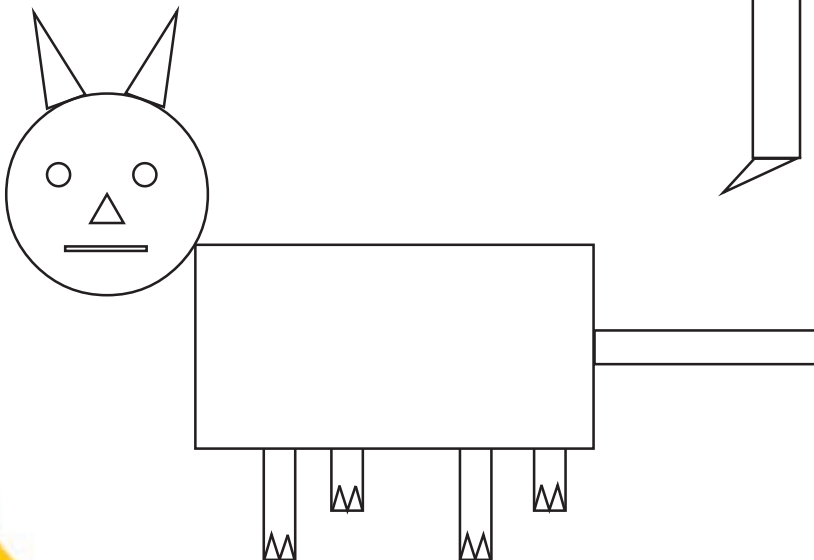
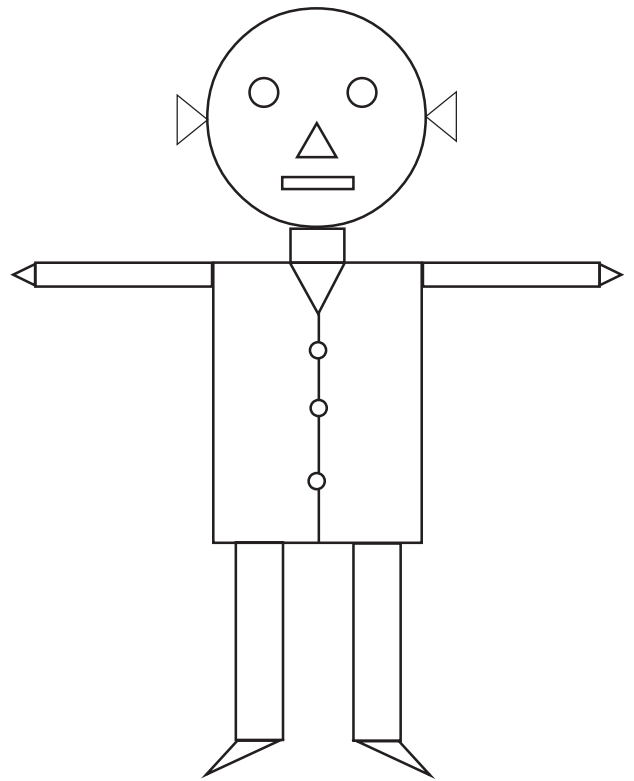

Give different colours to the pictures and make them beautiful.

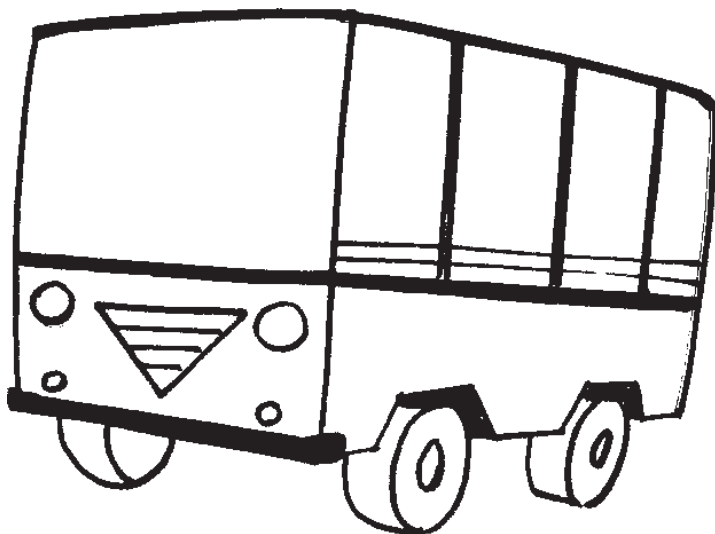

Let's join shapes

We can join shapes to make pictures. Take the suitable shapes from the Mathematics Lab to make the pictures given below.

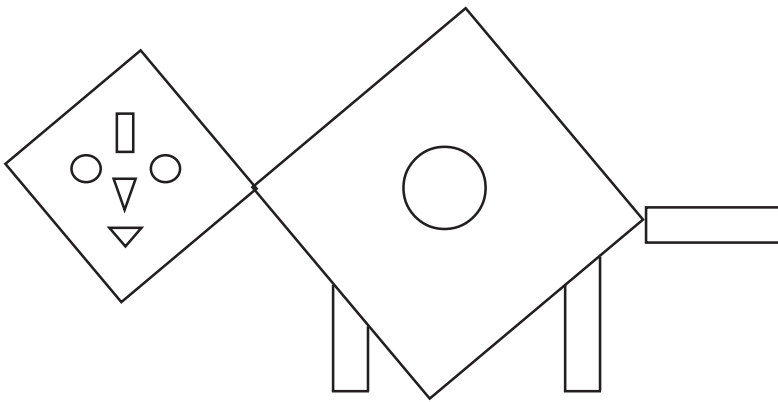

Let's make this

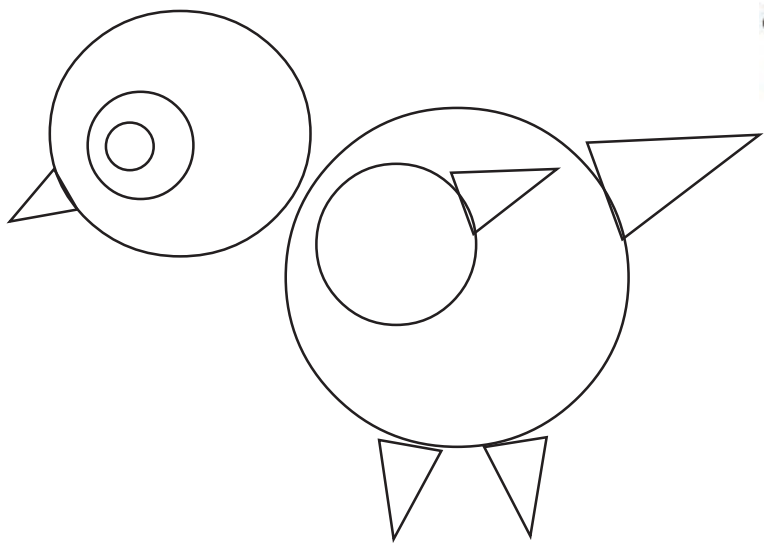

We can draw Mathematical Shapes

Software for the purpose: Tux Paint in IT@School GNU/Linux.

How to open the software,

Applications → Education → Tux Paint

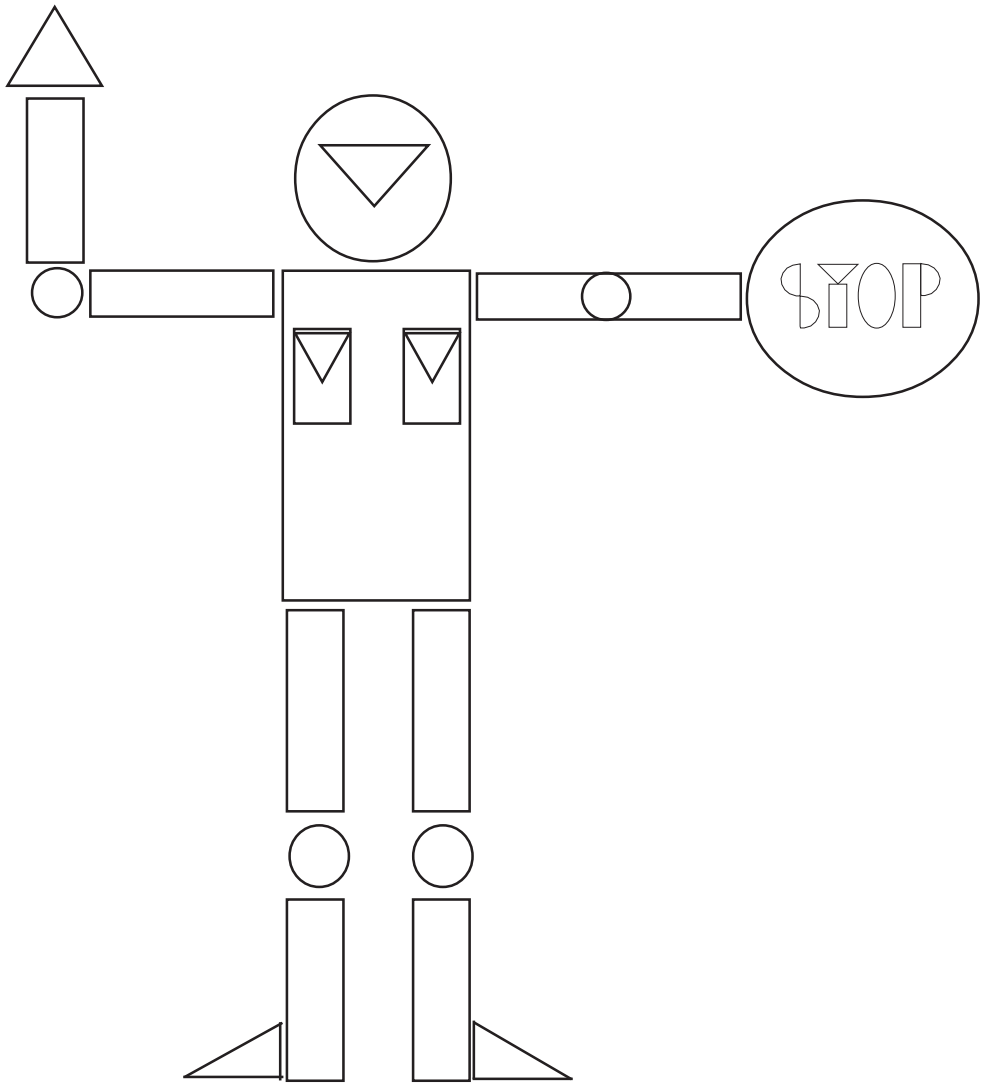

- Count and write the number of rectangles, triangles and circles in the above picture.

Triangle and Rectangle



Look at the pictures made by Anu and her friends using triangles and rectangles.

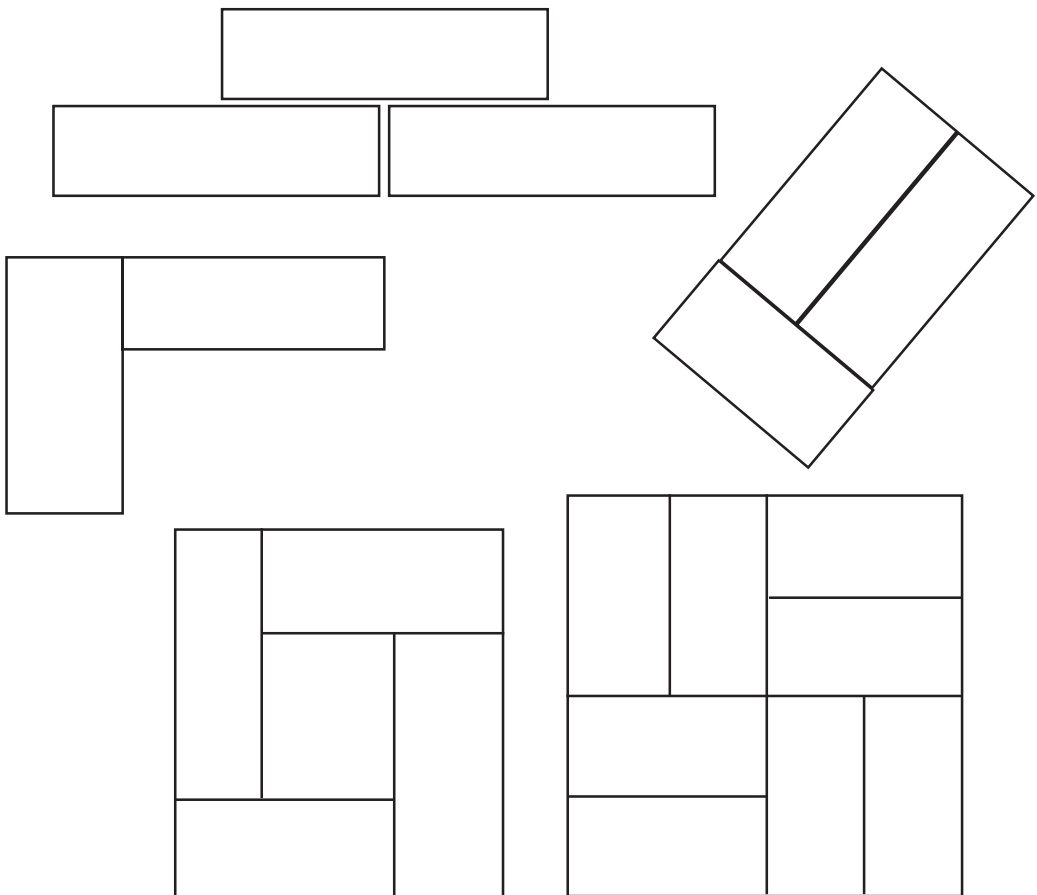

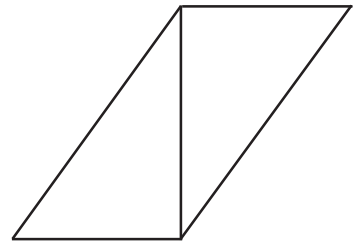
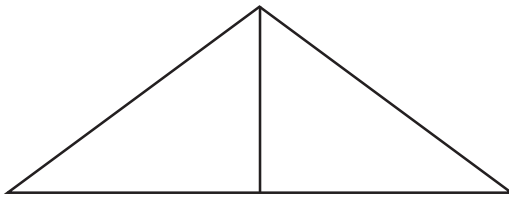
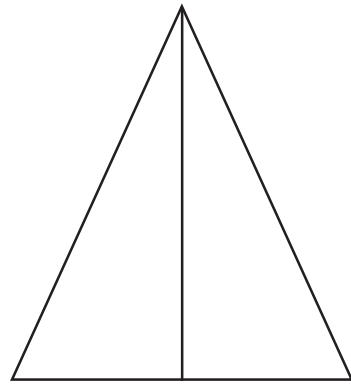
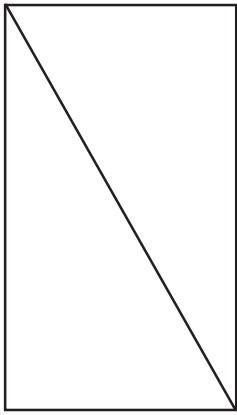

Let us also draw like this.

We need rectangles and triangles.

We can take these shapes from the Mathematics Lab.

We can use them to draw different shapes.

Give colours you like and exhibit them.



Look at the shapes made by Vinu and his friends.

We can make and draw many shapes by joining triangles and rectangles. Colour these pictures and make it beautiful.

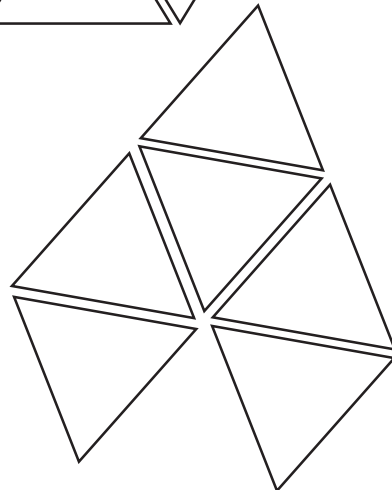
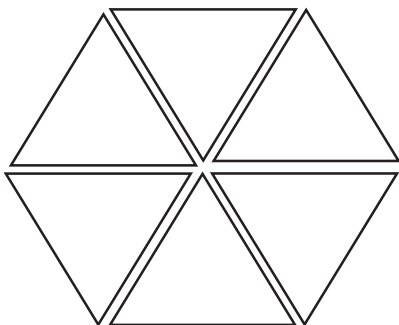
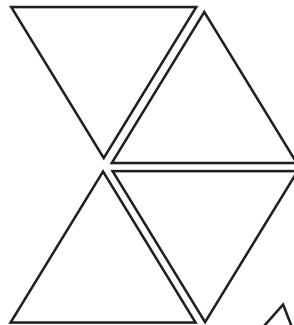
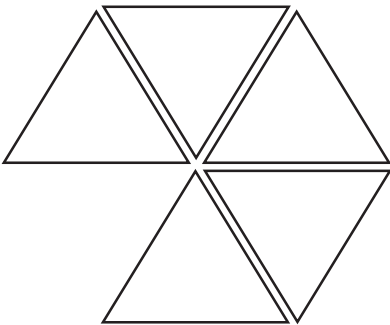
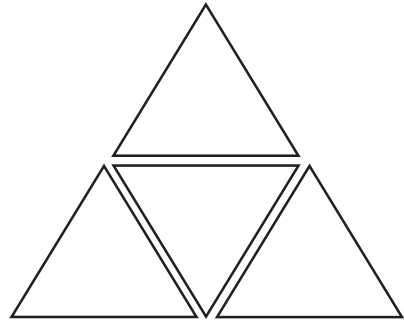
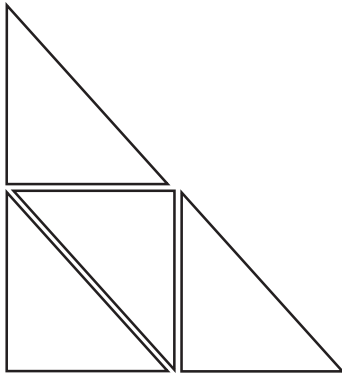

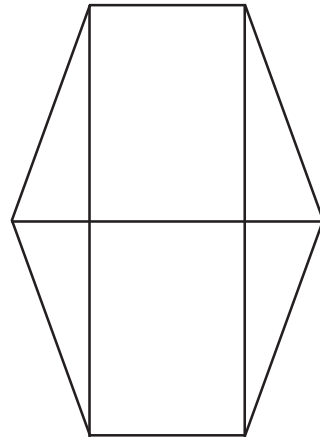
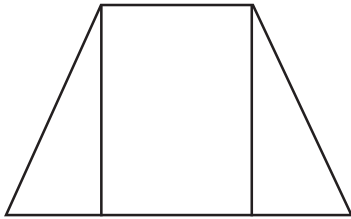
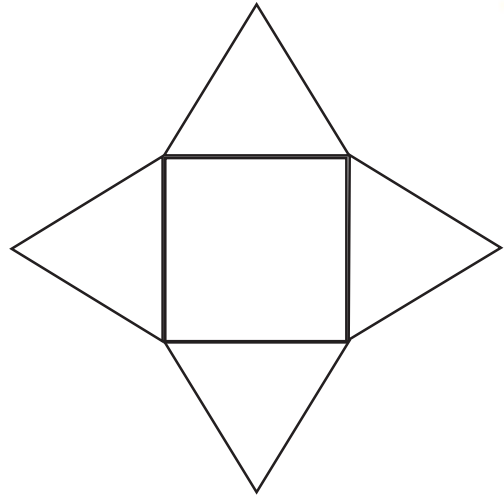
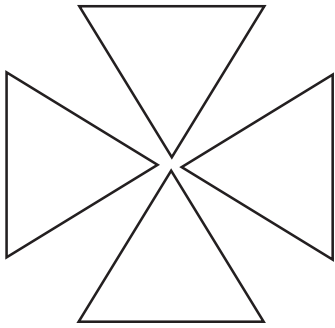

When I put together or drew

Corners are joined.

Edges of the figures are drawn straight.

There was a pattern in joining the shapes.

The pictures drawn are beautiful.

Let us draw a circle



We can draw pictures using circles

To draw a circle we can use a bangle or a coin

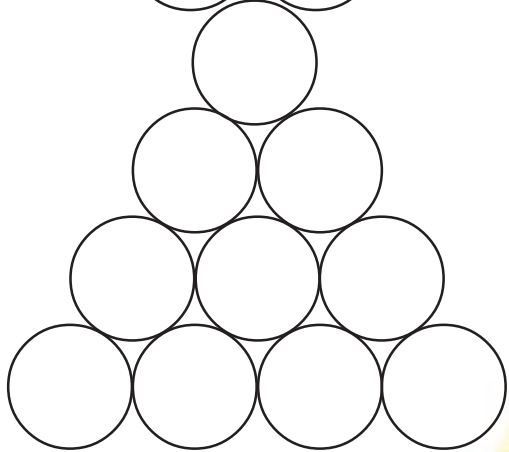
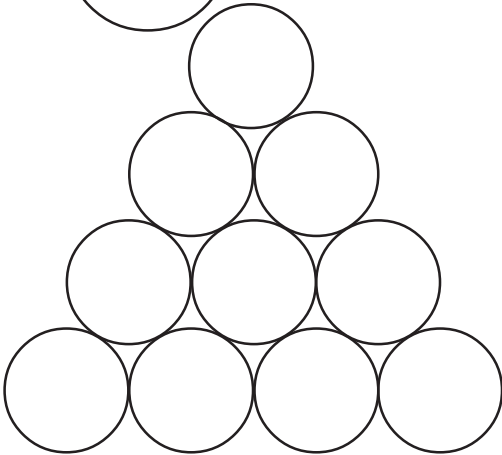
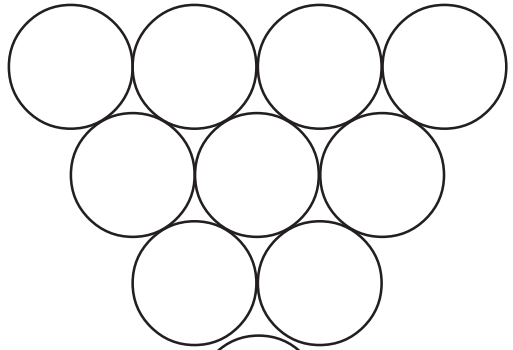
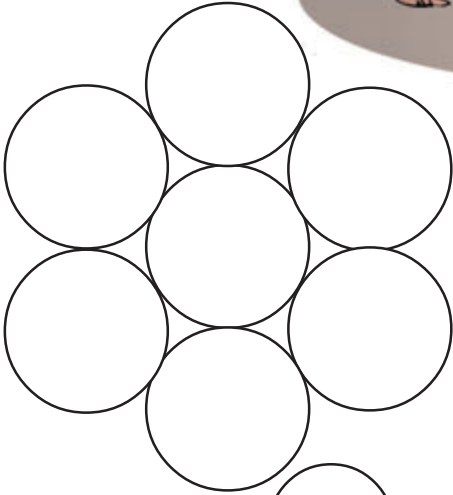

Colour the pictures

Figures of different shapes

I divided a square into 8 pieces.

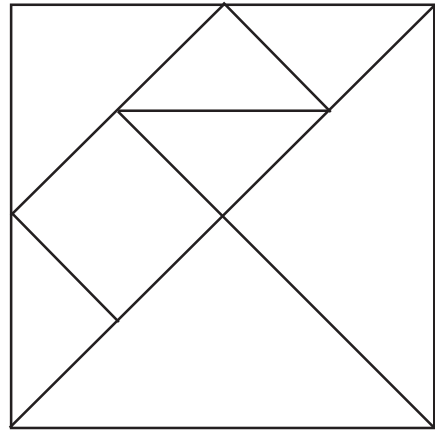

I will show you a trick

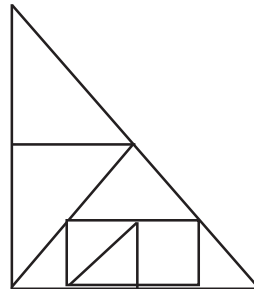
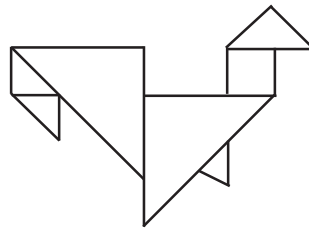
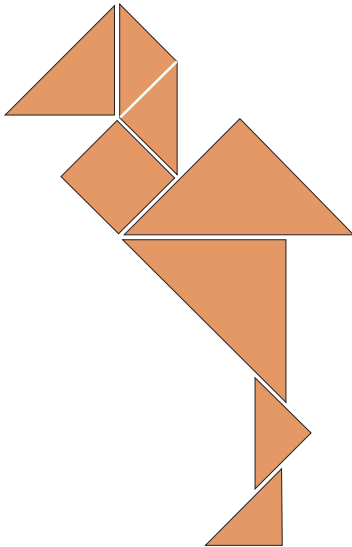

By joining these 8 pieces, let us try to draw the pictures given above. Try to draw more pictures.

Draw, draw and draw again!

- See the pictures drawn by joining the dots.
- Draw pictures of your choice by joining the dots.

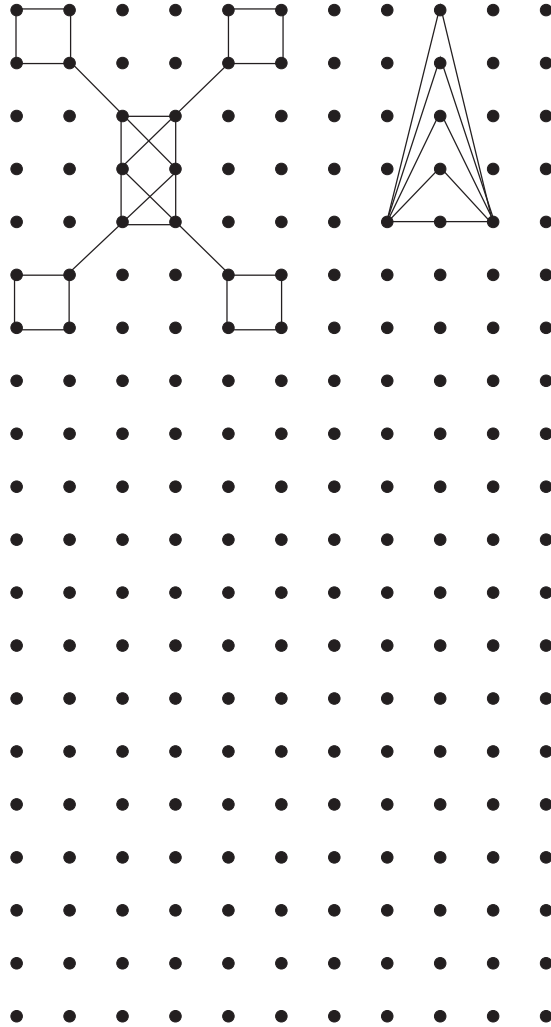

Constructions using Mathematical Shapes

Software for the purpose: GCompris in IT@School GNU/Linux.

How to open the software

GCompris → Puzzles → The tangram puzzle game

Shapes using sticks

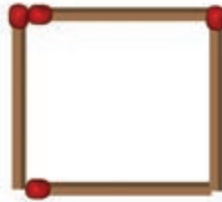
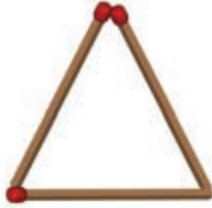

Using match sticks we can make triangles and rectangles.

How many match sticks are needed to make a triangle?



A rectangle?

A diagram of a 2x2 grid of matchsticks. Each vertex of the grid is marked with a small red dot.

By removing just two match sticks, can you make two rectangles?

A cartoon illustration of the same boy from the top left, looking towards the right. A speech bubble above him contains the question.

By removing one match stick, can you make two rectangles?

A cartoon illustration of the same girl from the top right, looking towards the left. A speech bubble above her contains the question.

Using sticks, make triangles and rectangles as given below.

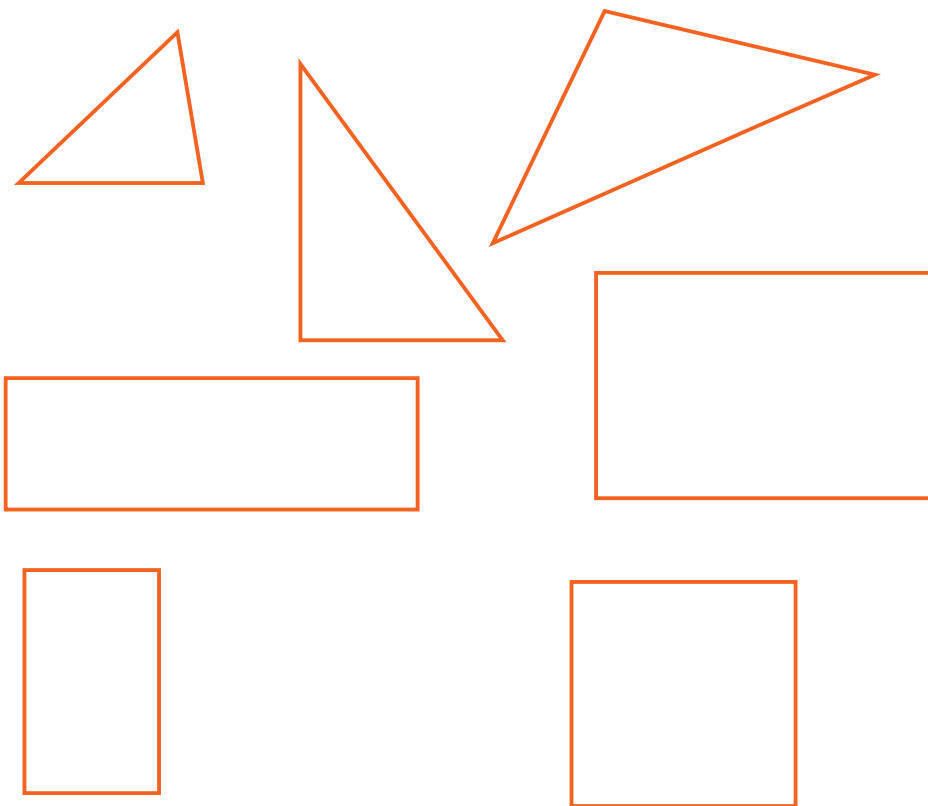

Paste the sticks neatly on a chart paper to make shapes.

A triangle has 3 sides.

How many sides does a



Can you see the house made with sticks?

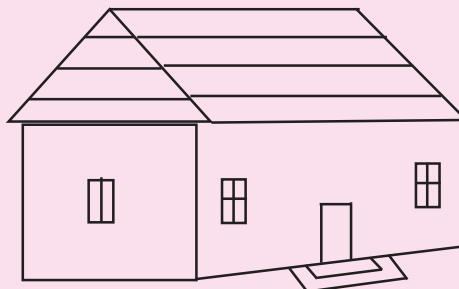

Rectangular Blocks

Try to write names of objects that are rectangular in shape.

- Brick
- Match Box
-
-
-



See the faces of the rectangular block.

Aren't they all rectangles?

How many faces do they have?

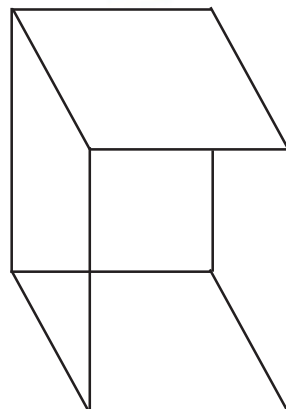

Draw the next picture

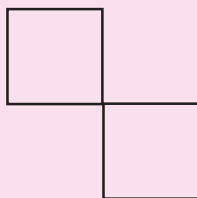
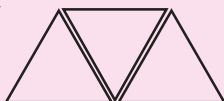
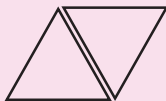

Cap and Boat

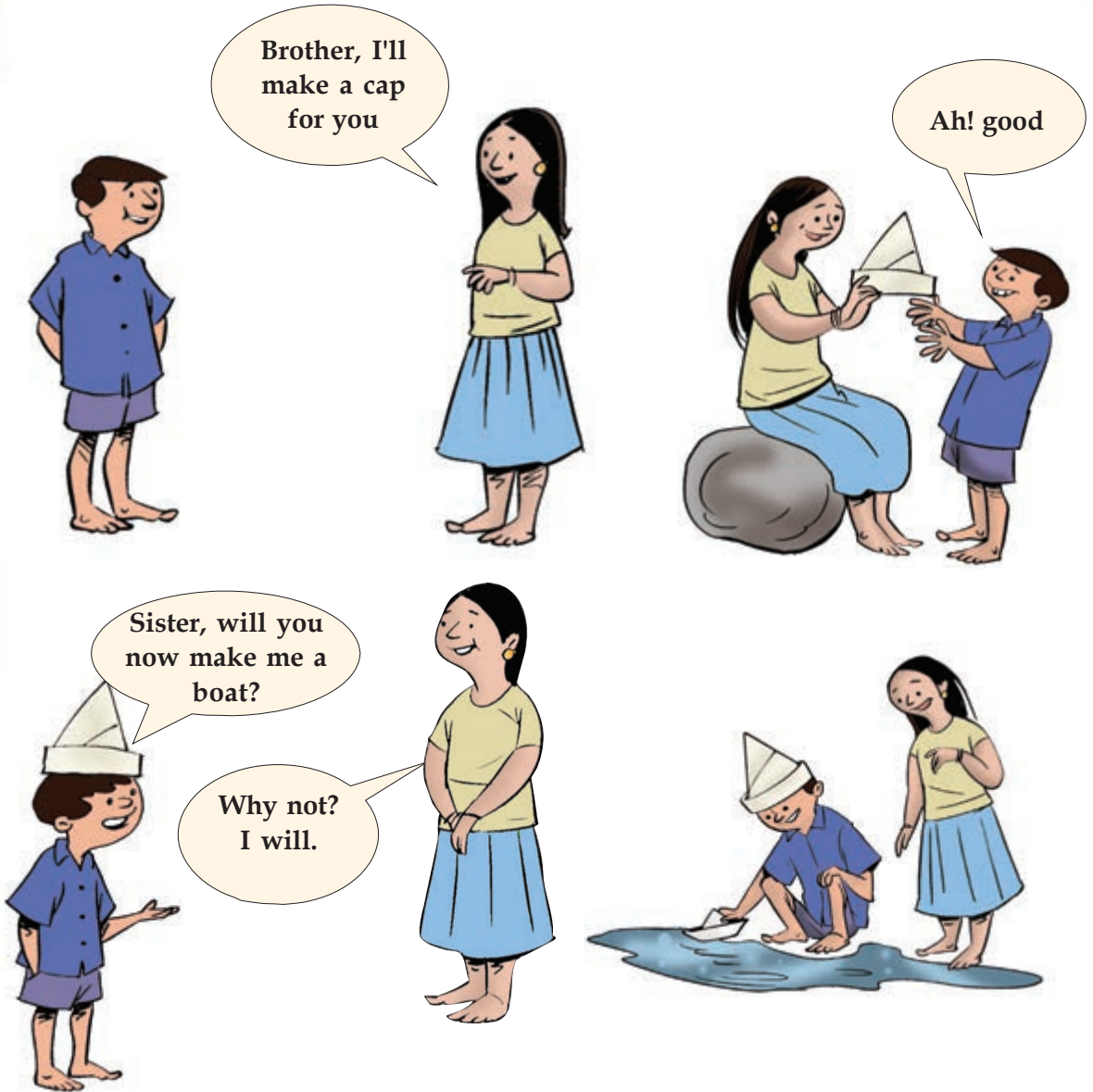

Can you make such models? What all toys can you make by folding paper? Don't forget to teach your friends too!

Notice the shapes formed when you fold the paper each time.

5

If Alike Joins

School Re-Opening Festival

New friends arrived. Sweets were given to every one.



Every one in my bench got two sweets each.

We are five in number.

What is the total number of sweets for us?

$$2 + 2 + 2 + 2 + 2 = 10$$

5 two's make 10.

Shorten this as $5 \times 2 = 10$.

If one more friend joins the group, then how many sweets are needed?

We can shorten this as

$$\dots \times \dots = \dots$$

Toy Cart

In the class, students are making toy carts.

Raju also made carts.

Three wheels for a cart.

Bottle tops were used as wheels.

Raju wants 4 carts.

How many bottle tops does he need?

$$3 + 3 + 3 + 3 = 12$$

Four 3's make 12

That is, $4 \times 3 = 12$.

Abu made two carts.

How many bottle tops did Abu use?

How many tops did both of them use ?

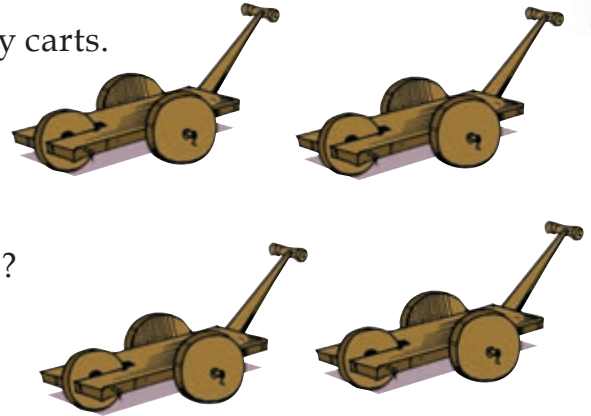

$$3 + 3 + 3 + 3 + 3 + 3 = 18$$

How can we shorten this?

$$\dots \times \dots = \dots$$



In Groups

For doing the activities in the mathematics lab the teacher arranged the students into groups.

There are 4 students in one group.

Total number of groups is 6.

What is the total number of students?

$$4 + 4 + 4 + 4 + 4 + 4 = \dots$$

$$6 \times 4 = \dots$$

How many Flowers?

In the Mathematics lab the students arranged the flowers as below.

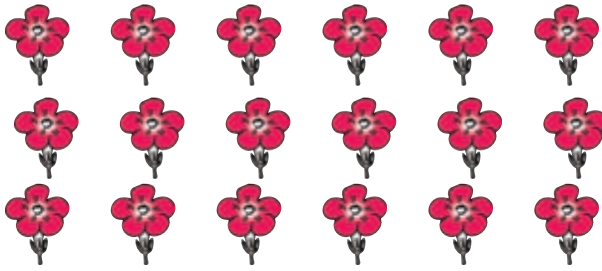

How many flowers are there in one row?

How many rows?

What is the total number
of flowers?

$$6 + \dots + \dots = \dots$$

$$\dots \times 6 = \dots$$

Complete the pattern

- 2, 4, 6,,,
- 3, 6, 9,,,
- 4, 8, 12,,,
- 5, 10, 15,,,
- 6, 12, 18,,,

Addition and Multiplication

Complete the table

	Three 4's make 12	$3 \times 4 = 12$
		$4 \times 3 = 12$
$6 + 6 = 12$		
	Six 2's make 12.	

Let us find

The cost of a pencil is 2 rupees. Find the cost of 10 pencils.	$10 \times 2 = 20$
A packet contains 6 candles. Find the number of candles in 4 such packets.	$4 \times 6 = \dots$
For stitching uniform, 3 metres of cloth is needed for a child. How much cloth is needed for 5 children?	$\dots = \dots$
What is the amount needed to buy 5 notebooks each costing rupees 5 ?	$\dots = \dots$
.....	$3 \times 4 = \dots$
Cost of a pen is 6 rupees. Find the cost of 6 pens.	$\dots = \dots$



Try These

- Ramu planted plaintain trees. Three trees in one row. What is the total number of trees in 6 rows?
- We can arrange 4 chairs around a table. How many chairs are needed to arrange around 4 tables?
- Glasses were purchased to distribute milk for the students. 5 boxes were purchased with 6 glasses each. Find the total number of glasses bought.

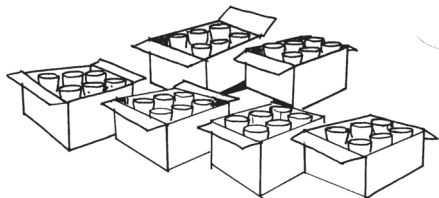

If order changed

The teacher is training the students who are participating in a sports meet.

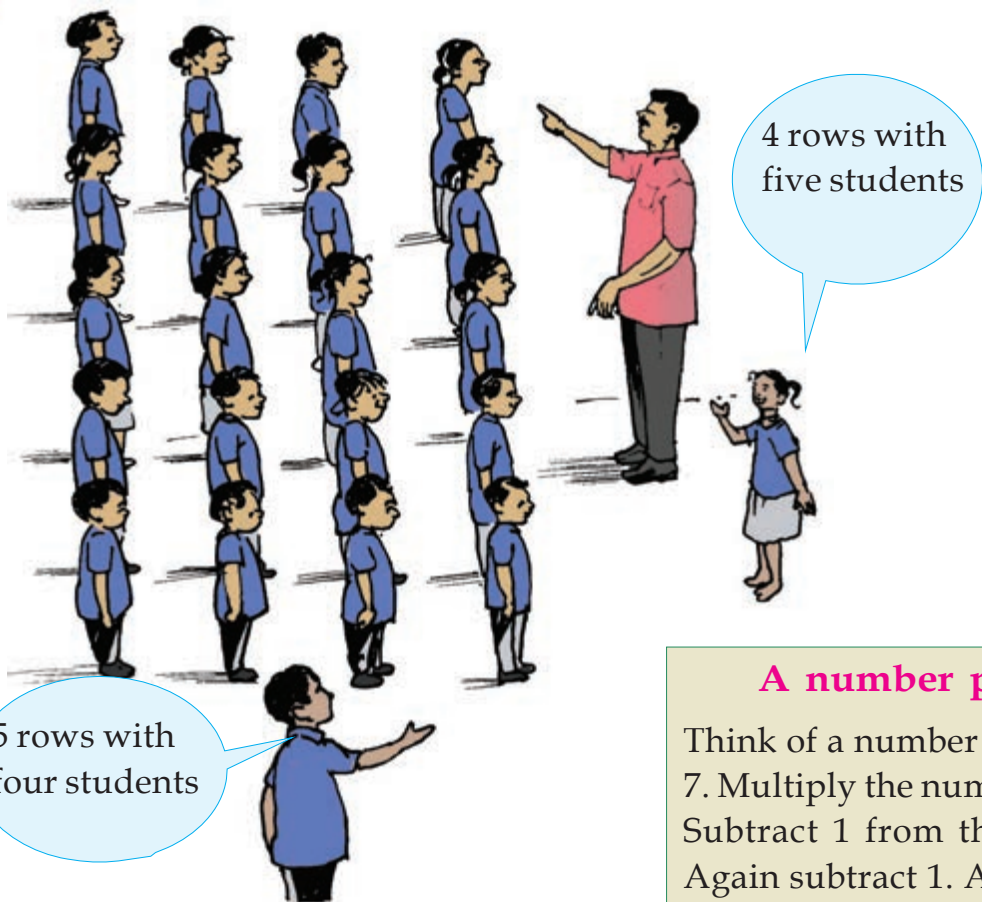

What is the total number of students?

Four 5's make

$$5 + 5 + 5 + 5 = \dots\dots\dots$$

$$4 \times 5 = \dots\dots\dots$$

Five 4's make

$$4 + 4 + 4 + 4 + 4 = \dots\dots\dots$$

$$5 \times 4 = \dots\dots\dots$$

$$\text{That is, } 4 \times 5 = 5 \times 4$$

A number play

Think of a number less than 7. Multiply the number by 3. Subtract 1 from the result. Again subtract 1. Add these three numbers.

- Find the sum of the digits in the answer.
- What did you get?
- Repeat the play with other numbers.
- What is the trick in the answer ?

How many dots?

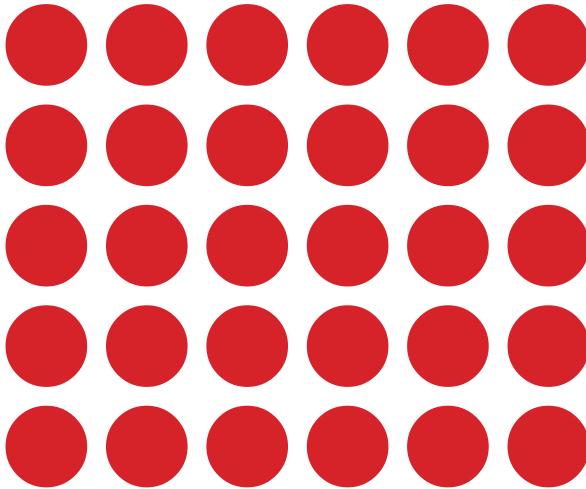

How many rows?

How many dots in one row?

What is the total number of dots?

$$6 + 6 + 6 + 6 + 6 = \dots\dots\dots$$

If we consider the columns, then

$$5 + 5 + 5 + 5 + 5 + 5 = \dots\dots\dots$$

That is,

$$5 \times 6 = 6 \times 5$$

Added or Multiplied

When three different numbers are added or multiplied, the answers are the same. Find the numbers.



Let's Multiply

Software for the purpose : GCompris in IT@School GNU/Linux. How to open the software,

GCompris → Mathematics → Go to calculation activities → Go to Algebra activities → Practice the multiplication operation

Try these

$$5 \times 4 = 4 \times 5$$

$$3 \times 2 = 2 \times 3$$

$$4 \times 3 = \dots \times \dots$$

$$\dots \times \dots = \dots \times \dots$$

Different ways.

12 is written as different groups. Look at these.

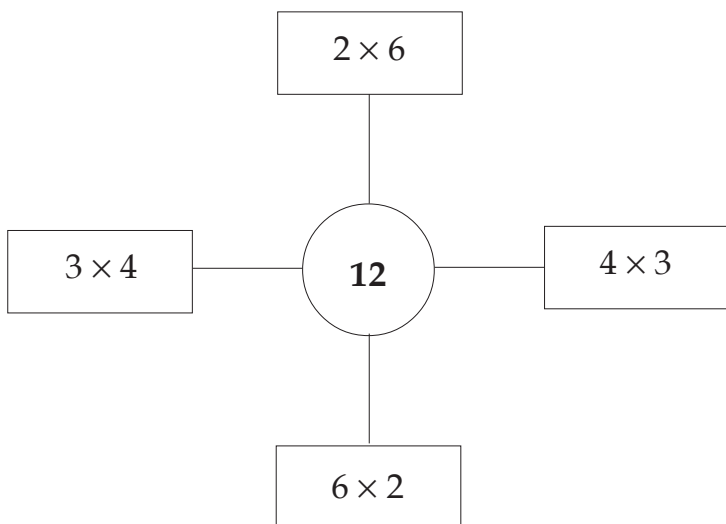

Saju bought 5 pens each costing 10. How many 5 rupee notes should he give to the shop keeper?

If it is 10 rupee notes...?

Similarly can you write 20 in different ways?

Appu's Magic

Think of a one digit number. Multiply it by 2.

Then again multiply by 5. Add 10.

Give the answer. I will tell the number you thought." Have you got Appus' trick?



Factor Number Munchers

Software for the purpose :
GCompris in IT@School GNU/
Linux

[GCompris](#) → [Mathematics](#) → [Go to calculation activities](#) → [Go to Number Munchers](#) → [Factor Number Munchers](#)

How can we arrange 8 bricks in different ways?

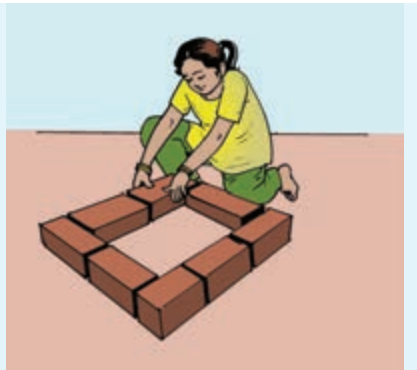

Complete the boxes

What is the peculiarity of the numbers in the white boxes?

Now complete the blank boxes.

Find and write the patterns from the boxes.

×	1	2	3	4	5	6
1	1					
2		4				
3			9			
4				16		
5					25	
6						36

Write the numbers in the coloured boxes. Find the sum of the numbers against each number.

What is the peculiarity of these numbers? Write the numbers in other boxes and find their sum.

×	1	2	3	4	5	6
1						
2						
3						
4						
5						
6						



Let's find the product

Software for the purpose : GCompris in IT@School GNU/Linux. How to open the software,

GCompris → Mathematics → Go to calculation activities

→ Go to Mathematics memory activities →

Multiplication memory game

Complete the table

From the previous table, write the groups of 3.

$$1 \times 3 = 3$$

$$2 \times 3 = 6$$

$$3 \times 3 = \dots\dots\dots$$

$$\dots\dots\dots = \dots\dots\dots$$

$$\dots\dots\dots = \dots\dots\dots$$

$$6 \times 3 = \dots\dots\dots$$

We can write the groups of 4 and 6 as

$1 \times 4 = \dots\dots\dots$
$\dots\dots\dots = \dots\dots\dots$
$\dots\dots\dots = \dots\dots\dots$
$\dots\dots\dots = \dots\dots\dots$
$6 \times 4 = \dots\dots\dots$

$\dots\dots\dots = \dots\dots\dots$
$\dots\dots\dots = \dots\dots\dots$
$\dots\dots\dots = \dots\dots\dots$
$\dots\dots\dots = \dots\dots\dots$
$6 \times 6 = \dots\dots\dots$

Way Home

Help the hen reach her house through the number boxes which are the answers of the problems given below.

5×5	3×2	5×3
6×6	4×3	5×2
2×2	6×3	6×5
3×3	6×2	5×4
4×4	4×2	6×4



25	36	17	14	11
5	4	9	16	6
21	31	13	22	12
33	15	8	12	18
24	10	30	20	24



School Store

Look at the Price List displayed in the school store.

- Manu bought 4 notebooks and 4 pens. What is the total cost?
- Maya bought 5 pencils and 2 sharpeners. What is the total cost ?
- Rahim bought 3 pencils and 2 erasers. What is the total cost ?
- Dennis bought 2 notebooks and 3 rulers. What is the total cost?
- Shefi has rupees 24 with her. What and how many items can she buy?
- Jameela teacher bought 4 each of all the items from the store. What amount did she give ?

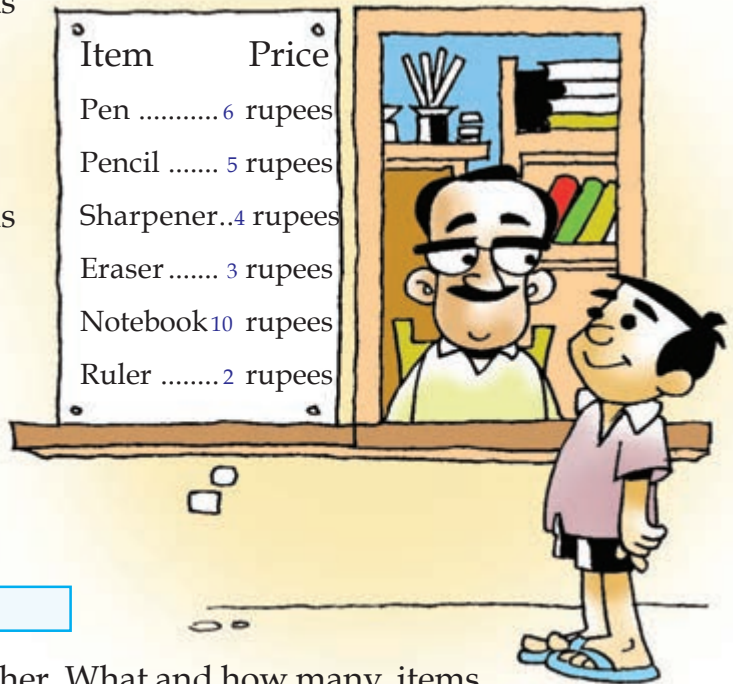

Based on the above Price List, prepare questions to ask you friends.

How I found out



How my friends found out



Football Match

For watching a football match, some friends started in 4 cars and 3 autorickshaws. In each car 5 persons and in each autorickshaw 3 persons. How many persons went for watching the match?

How many toy carts ?

Appu is making toy carts. Wheels are bottle tops. He made carts with 2 wheels, 3 wheels and 4 wheels.

Altogether he used 30 bottle tops.

How many toy carts did he make with two wheels?

Three wheels?

Four wheels?

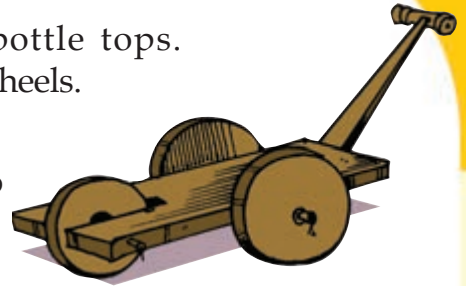

School Bus

Sabu counted the number of students in the school bus. " 6 seats on the right with 3 students each. 5 seats on the left with 2 students each. 4 including myself are standing." What is the total number of students in the bus?

In the next stop, students got down from 2 seats on the right and 3 seats on the left.

Now how many students are left in the bus?



- I bought 6 packets with 3 biscuits each . What is the total number of biscuits I bought?
- When the teacher divided the students into 5 groups of 4 each, one student was left out. When they were divided into 4 groups of 5 each, then also one student was left out. What is the total number of students?
- When 5 benches were occupied, each by 5 students, 5 were left out. Then how many students are there altogether? If each bench is to be occupied by 5 students with no one left out, then how many benches are needed?
- Ragi bought 4 notebooks and 6 pens. Cost of a notebook is 6 rupees and that of a pen is 3 rupees. For her brother, she bought 6 pencils each costing 2 rupees and 4 notebooks costing 5 rupees each. If she gave 100 rupees to the shopkeeper what amount did she get back?

Mary's U.P. School

In the School, 201 students were studying in the first standard, 14 students less than the first standard is in the second standard, 186 students in the third standard and in the fourth standard 18 students more than the number of students in the third standard. 195 students study in the fifth standard.

Which class has the most students? Find the total number of students in the LP Section.



Among the 213 students in the sixth standard, 114 were girls.

Seventh standard has 19 students more than the sixth standard. Number of boys and girls are equal in the seventh standard.

Eighth standard has 37 students less than the seven standard. There are 105 boys in the 8th standard.

Who are more in the U.P section, boys or girls? By how much?

What is the total number of students in the U.P section? Let us write this in a table.

Based on the table prepare questions to ask your friends.

6

Time



Aji's one day

He wakes up in the morning

6 O'clock



Takes bath

7 O'clock



Goes to school

9 O'clock

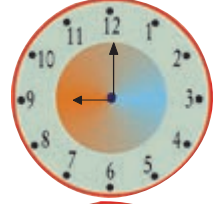

Class begins

10 O'clock



Takes lunch

1 O'clock



School time ends

4 O'clock



Studies at home

Night 7 O'clock

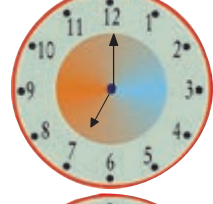

Sleeps

Night 9 O'clock





- What do you do in a day?
 - Wake up in the morning
 - Take bath
 - Study
 - Read news paper
 - Take breakfast
 - Go to school
 - Participate in the school assembly
 - Participate in the learning activities
 - Take lunch
 - Sing National Anthem
 - Play in the evening
 - Study at night
 - Write diary
 - Sleep



- What does your mother do in a day? Ask your mother.

-
-
-
-



Time

Doesn't your mother ask you to get ready for school by looking at the clock?
Doesn't the school ring the bell by looking at the clock.

Look at the time and the position of the two hands of the clock.

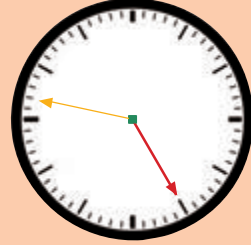
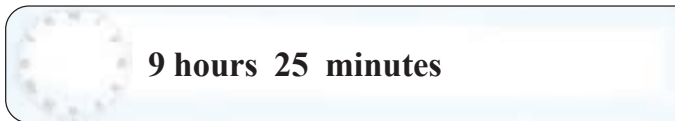
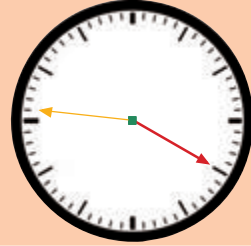
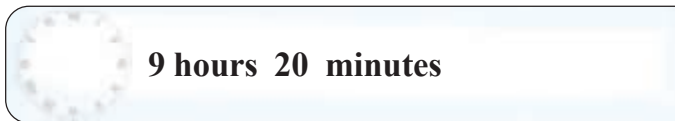
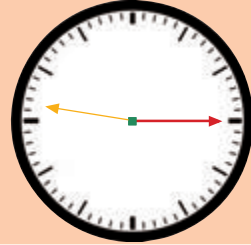
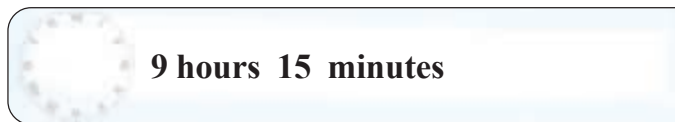
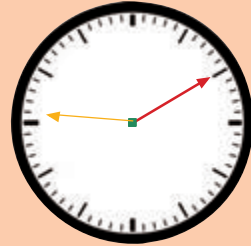
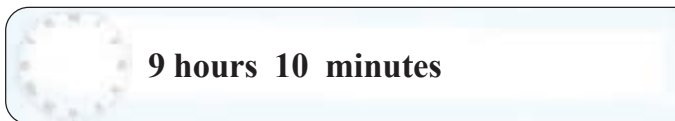
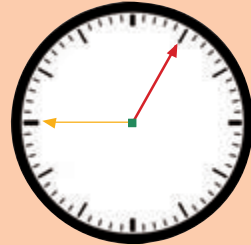
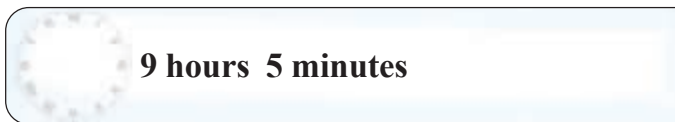
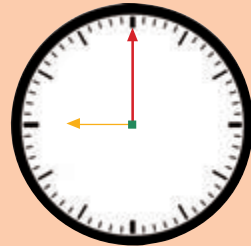



9 hours 30 minutes

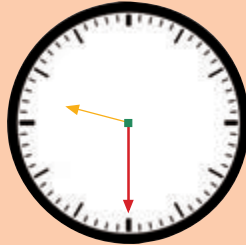

9 hours 35 minutes

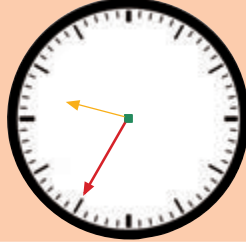

9 hours 40 minutes

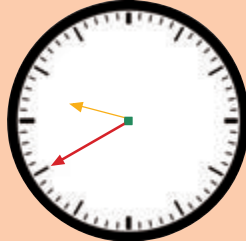

9 hours 45 minutes

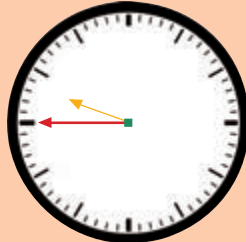

9 hours 50 minutes

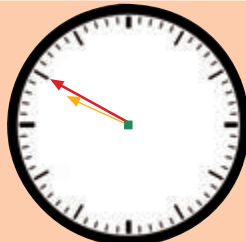

9 hours 55 minutes

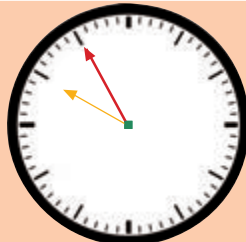

For the minute hand to rotate once from 12 to 12, 60 minutes is needed.

That is 1 hour is equal to 60 minutes.

My day



I wake up at and complete my routine work before and drink tea. After I start for school. After 2 periods there is a small interval. Lunch break is between and . The school ends at and I reach home before . At I read my lessons and sleep at .



Can you write the time below?

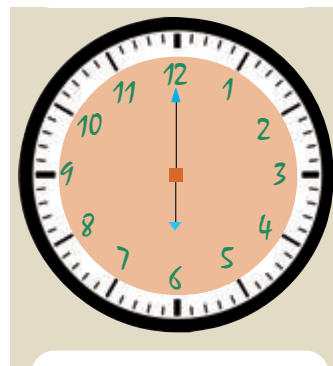
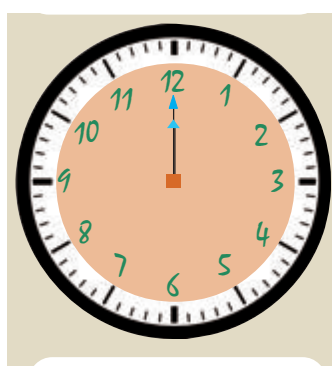
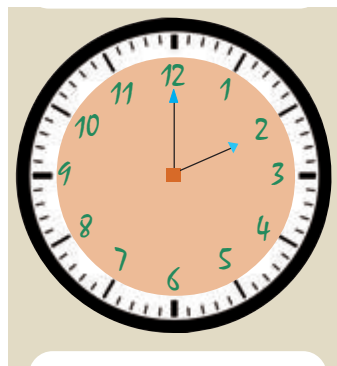
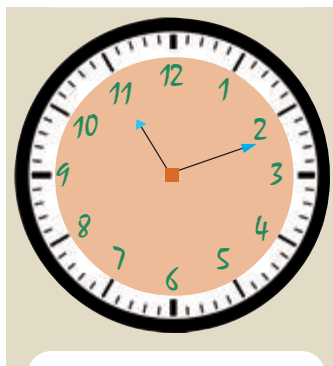
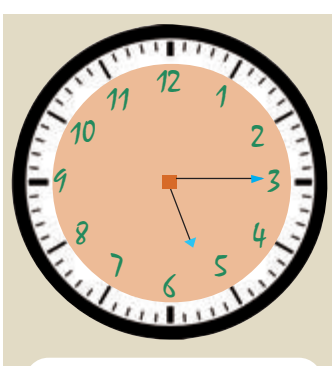
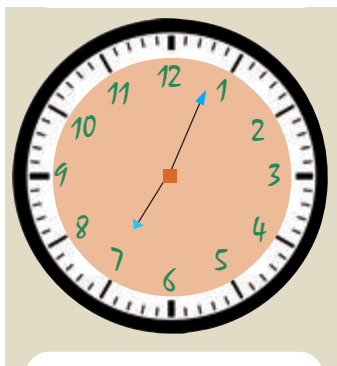
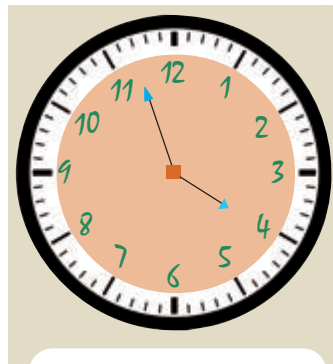
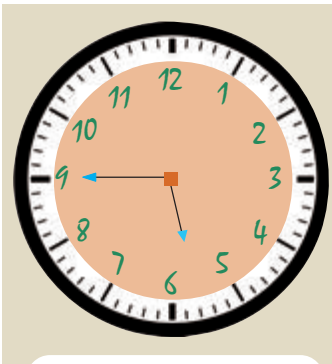
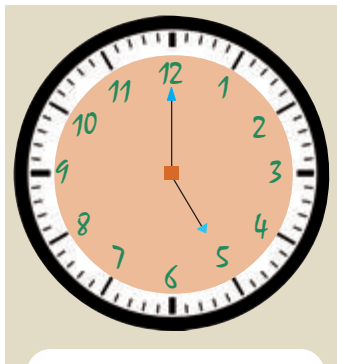

Draw the two hands of the clock



6 hours 20 minutes

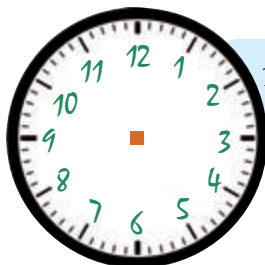

10 hours 11 minutes

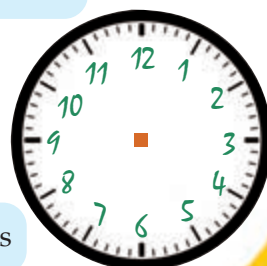

2 hours 47 minutes

Jungle Olympiad

A running competition is being conducted in the forest in connection with the Forest Day Celebrations .

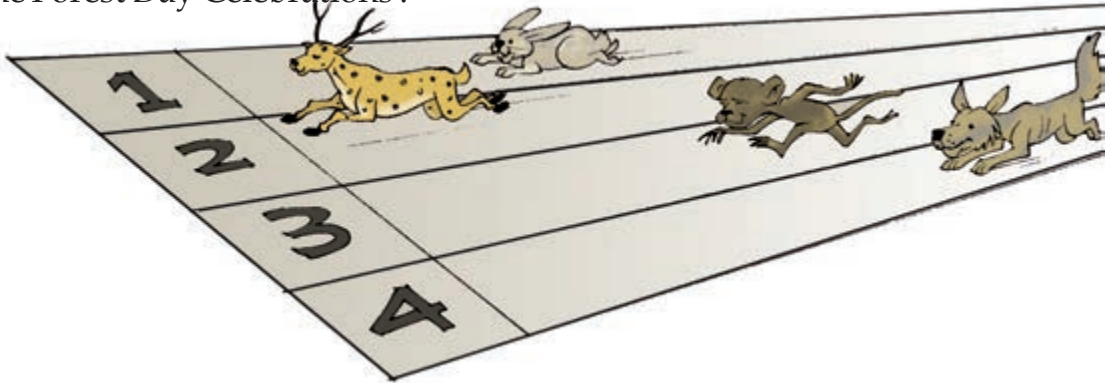

Chinnu Deer completed the race in 1 minute and Chinthu Rabbit in 2 minutes. While Chinju fox completed in 3 minutes, Chindan monkey took 4 minutes.

The competition started at 10 O'clock in the morning. Note the time taken by each of them.

- Chinnu deer - 10 hours 1 minute
- Chinthu rabbit - 10 hours 2 minutes
- Chinju fox - 10 hours 3 minutes
- Chindan monkey - 10 hours 4 minutes

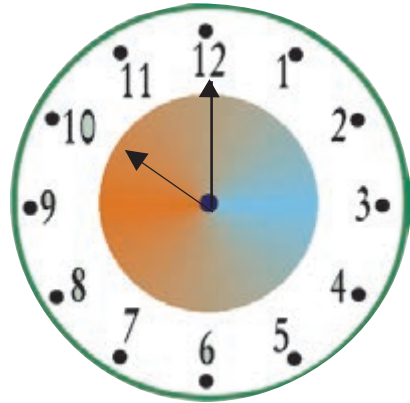

We can show these times in clocks.

Chinnu



Chinthu



Chinju



Chindan



10 hours 1 minute

One Second

To blink the eye.....
To count from 1 to 3
For a chalk piece to fall
down from the table.
What is the time taken?



Second is used to represent time that is less than a minute.

Oh! if it was
1 second
earlier!



Let's set the time

Software for the purpose : GCompris in IT@School GNU/
Linux. How to open the software

GCompris → Go to discovery activities → Miscella-
neous activities → Learning clock

How many hours?

- From 6 O'clock in the morning to 6 O'clock in the evening. hours
- From 10 O'clock in the morning to 4 O'clock in the evening. hours
- From 6 O'clock in the morning to 1 O'clock in the afternoon. hours
- From 12 noon to 12 midnight. hours
- 7 O'clock in the morning to 7 O'clock the next morning. hours



My distance and time

Aji starts from home at 9 hours 30 minutes and reaches school in 20 minutes.

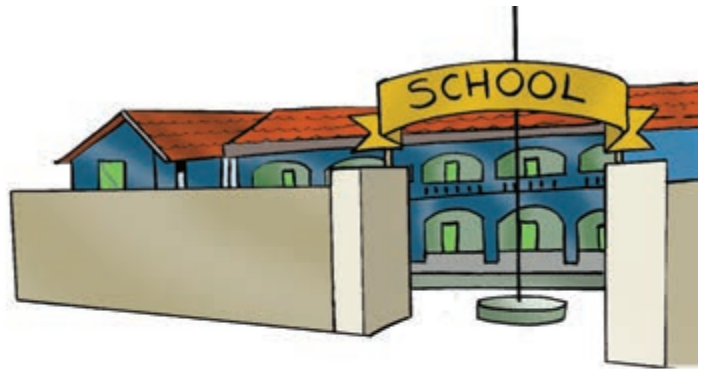

Isn't it better to say that the starting time is 9:30?



When did Aji reach the school?

- Write the time taken by your friends to travel from their homes to school?

Sl.No.	Name	Departure time	Arrival time	Time taken
1				
2				
3				
4				
5				

School Anniversary



What is the time now?

In the Railway Station

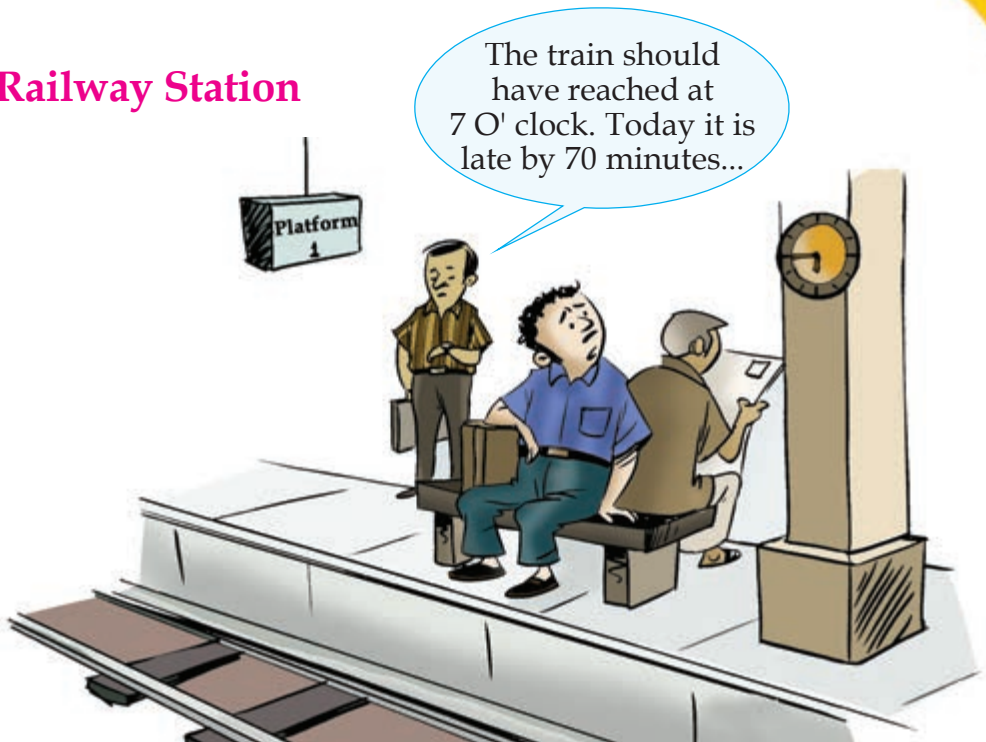

■ When will the train reach the station?

Car journey



■ Find the total time taken by them?

How I found out



How my friends found out



Journey by train

Venad Express starts at 5 in the morning from Thiruvananthapuram railway station and reaches Shornur station by 12:45 in the after noon.

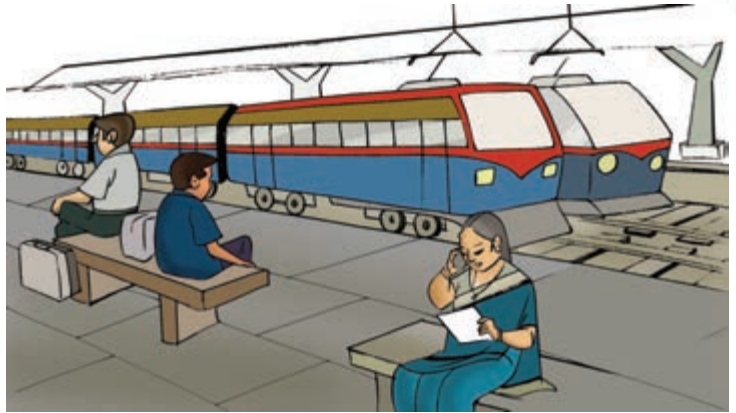

■ What is the total journey time?

Who is first?

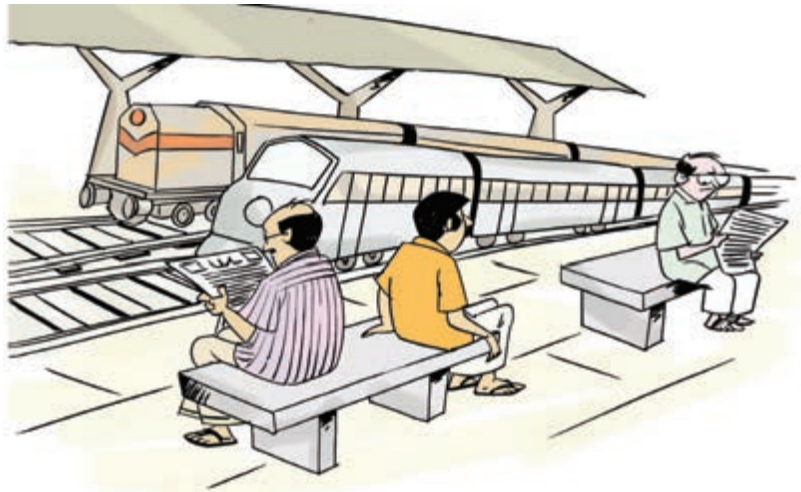

A train starts from Thiruvananthapuram at 7:30 in the morning and reaches Ernakulam at 11:35 in the morning via Alappuzha. Another train starts from Thiruvananthapuram at 5 O'clock in the evening and reaches Ernakulam via Kottayam at 9:55 in the night.

- Find the time taken by each train to travel from Thiruvananthapuram to Ernakulam?
- What is the difference in time?

Study Tour

Vijayamma teacher explained the tour like this.

We will be starting at 7:30 in the morning. After an hour, we shall reach the dam. We have an hour for sight seeing. From there, we will reach the Zoo after 30 minutes. We will see the birds and animals there. After spending 2 hours in the Zoo, we will travel 30 minutes to reach the Science Museum. We have one hour to see the Museum. After a lunch break of 45 minutes and we shall travel another 45 minutes to reach the History Museum. We will spent an hour in the History Museum and then travel 15 minutes and reach the beach. You can spent two hours there. Then we will return to our school by travelling one hour.

- Have you listened to the teacher?

We can write this plan in a table.

- The journey time and time spent in each place can be noted separately.

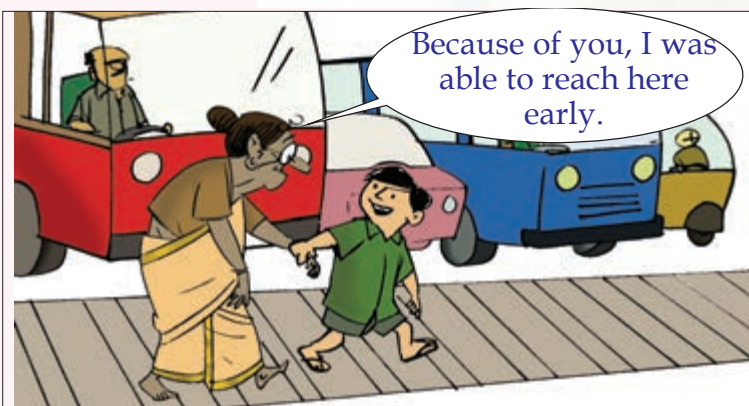

Journey time

Departure place time	Arrival place time	Time taken for the journey
School 7:30	Dam 8:30	1 hour
Dam 9:30	Zoo 10:00	

Visiting time

Arrival time	Departure time	Time spent
Dam 8:30	9:30	1 hour
Zoo 10:00		

- When did they reach the Science Museum?
- When did they have their lunch?

Based on the table above, make questions to ask your friends.

Working hours

Three persons mentioned the time taken by them to complete the same work in different ways.

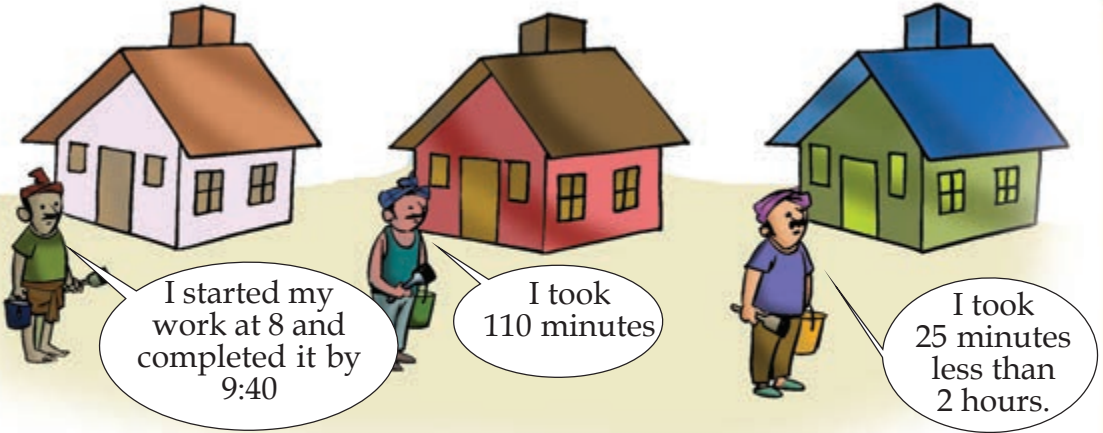

Who worked more time?

How I found out



How my friends found out



Understood, what to find out	<input type="checkbox"/>
Calculated time using hour - minute relations	<input type="checkbox"/>
Could explain the method of finding the time	<input type="checkbox"/>

Let's find out

- In which month is your birthday?
- Which is the first month of the year?
- In which month does your school open after summer vacation?
- Which are the months of this year with 5 sundays?
- On which day will we celebrate our Independence Day this year?
- Which is the month with number of days less than 30?
- Find the number of months with 31 days?
- How many months have 30 days?
- What is the total number of days this year?



Celebrations

- Write the names of the month in which we celebrate the following

This year's Onam is in August or September?



Celebration	English month
• Onam	
• Christmas	
• Vishu	
• Bakrid	
• Independence Day	
• Republic Day	
• Gandhi Jayanthi	
• Children's day	
• Kerala day	
• Teacher's Day	
• Environment Day	
•	
•	

Malayalam Months



- In which Malayalam month is Minnu's Birthday?
- Using a calendar, write the names of Malayalam months and English months in the table below.

<i>English Month</i>
March

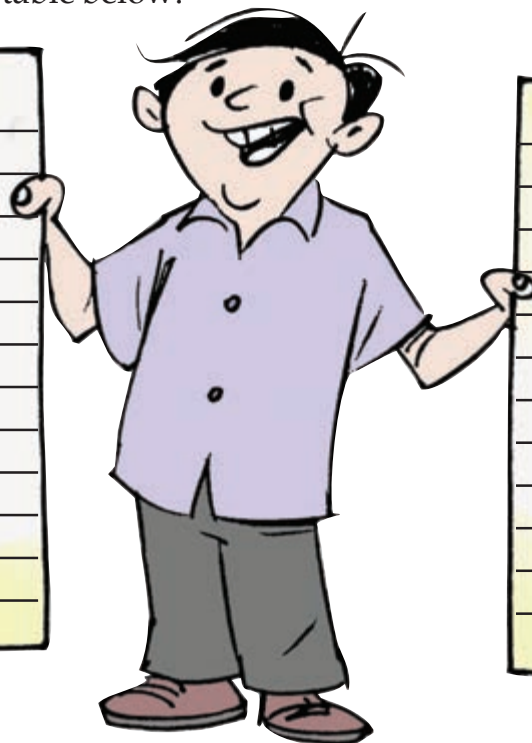

<i>Malayalam Month</i>
Chingam
Karkkidakam



How can we say?

Write the time required for the following.

- A plant to grow into a tree
- The school re-opens after summer vacation
- Egg hatches into chicks
- Fruits from flowers
- The sun rises in the morning and sets in the evening
- Return home from school
- Sings morning prayer in the school
- Takes breakfast
- Count from 1 to 50
- A frog to jump once

Looking back

Learning achievements	I can do it	Teacher's help is needed	Needs improvement
Chapter 1 - Hundred and above			
• Read numbers upto 999			
• Explain numbers upto 999 in different ways			
• Expand a number using place value			
• Using three digits, make three digit numbers			
• Find smaller/ larger from three digit numbers			
• Arrange three digit numbers in the ascending/ descending order			
• Use numbers to represent positions			
• Use numbers for problem solving			
• Explain the logic in the number sequences and find new number sequences.			
Chapter 2 - We can add			
• Represent a number as the sum of different numbers			
• Explain different methods of adding numbers to a three digit number.			
• Use addition to solve practical problems			
• Explain different methods of problem solving			

Learning achievements	I can do it	Teacher's help is needed	Needs improvement
<ul style="list-style-type: none"> • After verifying the properties of numbers, make conclusions regarding number relations 			
<ul style="list-style-type: none"> • Explain the logic in the number sequences 			
Chapter 3 - To take away			
<ul style="list-style-type: none"> • Explain different methods of subtracting numbers 			
<ul style="list-style-type: none"> • Use subtraction to solve practical problems 			
<ul style="list-style-type: none"> • Explain different methods of problem solving 			
<ul style="list-style-type: none"> • Justify the method of verifying the operation subtraction 			
<ul style="list-style-type: none"> • Make conclusions regarding the properties of numbers 			
<ul style="list-style-type: none"> • Explain the logic in the number sequences 			
Chapter 4 - When Shapes Join			
<ul style="list-style-type: none"> • Recognise rectangles, triangles and circles from the surrounding 			
<ul style="list-style-type: none"> • Make different figures using rectangles, triangles and circles 			
<ul style="list-style-type: none"> • Make different figures using Tangram 			
<ul style="list-style-type: none"> • Make three dimensional objects 			
<ul style="list-style-type: none"> • Take measures accurately and precisely 			

Learning achievements	I can do it	Teacher's help is needed	Needs improvement
Chapter 5 - If Alike Joins			
• Form multiplication concepts from practical situations			
• Use multiplication concepts to solve problems in practical situations			
• Use multiplication to solve practical problems			
• Find number relations using multiplication concept and explain.			
Chapter 6 - Time			
• Tell time by looking at the watch/ clock			
• Find the time span between two time periods			
• Explain the hour - minute relationship			
• Construct time table for planning			
• Find dates and important days in English/ Malayalam months using a calendar.			