

CHAPTER-1**ELECTRIC CHARGES AND FIELDS**

(Prepared by AYYAPPAN C, HSST, GMRHSS KASARAGOD)

Electric Charge

- **Electric charge** is the physical property of matter that causes it to experience a force when placed in an electromagnetic field.
- **The two types of charges are positive and negative (Named by Benjamin Franklin)**
- **Like charges** repels and unlike charges attracts.
- When amber rubbed with wool or silk cloth attracts light objects – discovered by Thales.
- **Electroscope** – device for charge detection
- It is a **scalar quantity** .
- SI unit of electric charge- **coulomb (C)**
- Charge of a proton is positive (1.602192×10^{-19} C)
- Charge of an electron is negative ($-1.602192 \times 10^{-19}$ C)
- Matter with **equal number of electrons and protons** are **electrically neutral**.
- Matter with excess number of electrons – negatively charged
- Matter with excess protons – positively charged.

Coulomb's law

- The force of attraction or repulsion between two stationary electric charges is directly proportional to the product of the charges and inversely proportional to the square of the distance between them.



- Force between two stationary charges is

$$F = \frac{1}{4\pi\epsilon_0\epsilon_r} \frac{q_1q_2}{r^2}$$

- Where ϵ_0 -permittivity of free space, ϵ_r - relative permittivity.

- Relative permittivity is given by , $\epsilon_r = \frac{\epsilon}{\epsilon_0}$

- ϵ - Permittivity of the medium.

- Also $\epsilon_0 = 8.854 \times 10^{-12} \text{ C}^2\text{N}^{-1}\text{m}^{-2}$

- Thus $\frac{1}{4\pi\epsilon_0} = 9 \times 10^9$

Definition of coulomb

- When $q_1 = q_2 = 1 \text{ C}$, $r = 1 \text{ m}$, $F = 9 \times 10^9 \text{ N}$
- 1 C is the charge that when placed at a distance of 1 m from another charge of the same magnitude *in vacuum* experiences an electrical force of repulsion of magnitude $9 \times 10^9 \text{ N}$.

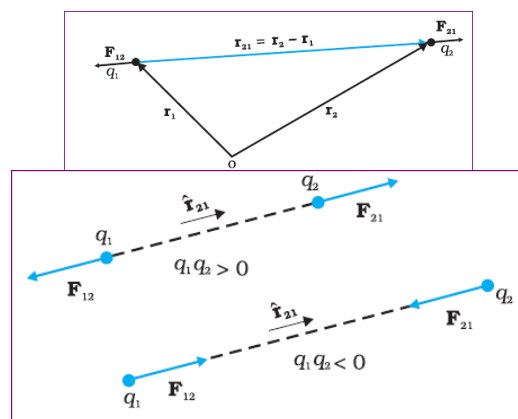
Coulomb's law in vector form

- Force on q_1 due to q_2 is,

$$\vec{F}_{12} = \frac{1}{4\pi\epsilon_0} \frac{q_1q_2}{r^2} \hat{r}_{12}$$

- Force on q_2 due to q_1 is,

$$\vec{F}_{21} = \frac{1}{4\pi\epsilon_0} \frac{q_1q_2}{r^2} \hat{r}_{21}$$

- Thus $F_{12} = -F_{21}$, Coulomb's law agrees with Newton's third law.

Electric field

- Region around a charge where its effect can be felt.
- Intensity of electric field at a point is the force per unit charge.

$$E = \frac{F}{q}$$

$$F = qE$$

- Unit of electric field is N/C or V/m.
- It is a vector quantity.

Electric field due to a point charge

$$E = \frac{1}{4\pi\epsilon_0} \frac{q}{r^2}$$

Electric field due to a system of charges

- Total electric field at a point due to a system of charges is the vector sum of the field due to individual charges.



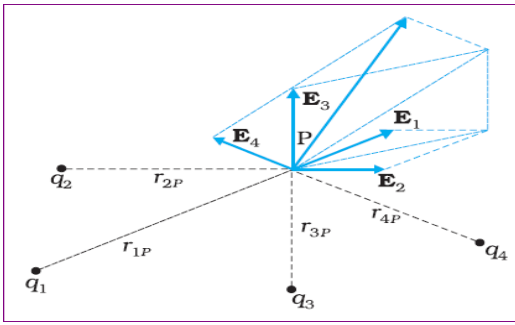

$$\mathbf{E}(\mathbf{r}) = \frac{1}{4\pi\epsilon_0} \sum_{i=1}^n \frac{q_i}{r_{iP}^2} \hat{\mathbf{i}}_{iP}$$

Electric field lines

- Pictorial representation of electric field.
- Electric field line is a curve drawn in such a way that the tangent to it at each point is in the direction of the net field at that point.

Properties of field lines

- Start from positive charge, end at negative charge. Do not form closed loops.
- Field lines are continuous in a charge free region.
- Two field lines never intersect. (Reason: two directions for electric field is not possible at a point)
- Field lines are parallel in uniform electric field.
- Tangent at any point gives direction of electric field.
- Number of field lines gives intensity of electric field.

positive charge

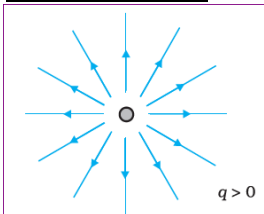

negative charge

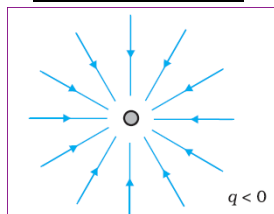

Positive and negative charge (dipole)

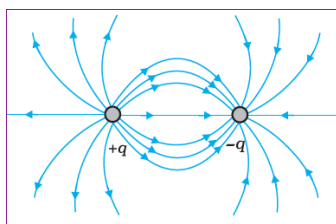

Two positive charges

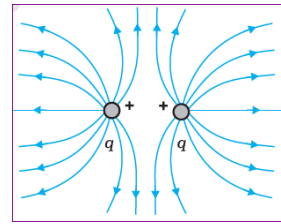

Electric Dipole

- Two equal and opposite charges separated by a small distance.

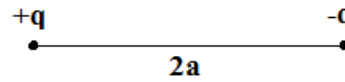

- Total charge and force on a dipole is **zero**.

Dipole moment

- Product of charge and dipole length.

$$p = q \times 2a$$

q- charge, 2a- dipole length

- Direction is from negative to positive charge.
- SI unit- coulomb metre (C m)

Electric field due to a dipole

Axial point

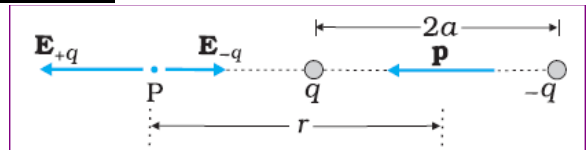

- The field at the point P due to positive charge is

$$\mathbf{E}_{+q} = \frac{q}{4\pi\epsilon_0(r-a)^2} \hat{\mathbf{p}}$$

- The field due to negative charge is

$$\mathbf{E}_{-q} = -\frac{q}{4\pi\epsilon_0(r+a)^2} \hat{\mathbf{p}}$$

- Thus the total electric field at P is

$$\mathbf{E} = \mathbf{E}_{+q} + \mathbf{E}_{-q} = \frac{q}{4\pi\epsilon_0} \left[\frac{1}{(r-a)^2} - \frac{1}{(r+a)^2} \right] \hat{\mathbf{p}}$$

$$\vec{E} = \frac{q}{4\pi\epsilon_0} \left[\frac{(r+a)^2 - (r-a)^2}{(r+a)^2 \times (r-a)^2} \right] \hat{\mathbf{p}}$$

- Simplifying

$$\vec{E} = \frac{q}{4\pi\epsilon_0} \left[\frac{4ar}{(r^2 - a^2)^2} \right] \hat{\mathbf{p}}$$

- For $r \gg a$, we get $\vec{E} = \frac{1}{4\pi\epsilon_0} \left[\frac{4qa}{r^3} \right] \hat{\mathbf{p}}$

- Using $p = q \times 2a$

$$\vec{E} = \frac{1}{4\pi\epsilon_0} \left[\frac{2p}{r^3} \right] \hat{p}$$

$$\vec{E} = \frac{-p}{4\pi\epsilon_0 r^3} \hat{p}$$

- Equatorial field

- Thus

$$E_{axial} = 2 \times E_{equatorial}$$

Physical significance of electric dipole

Non Polar molecules

- The molecules in which positive centre of charge and negative centre of charge lie at the same place.
- Dipole moment is zero for a non polar molecule in the absence of an external field.
- They develop a dipole moment when an electric field is applied.
- Eg: CO₂, CH₄, etc.

Polar molecules

- The molecules in which the centres of negative charges and of positive charges do not coincide.
- Eg: water

Electric flux

- Number of field lines passing normal through a surface.

$$\phi = EA \cos \theta$$

- Or

$$\Delta\phi = \mathbf{E} \cdot \Delta\mathbf{S} = E \Delta S \cos \theta$$

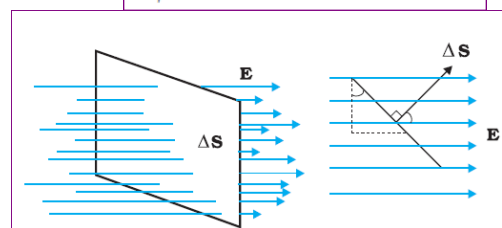

- Unit – Nm²/ C
- It is a scalar quantity

Charge density

Linear charge density (λ)

- It is the charge per unit length.

$$\lambda = \frac{Q}{l}$$

- SI unit is C/m.

Surface charge density (σ)

- It is the charge per unit area.

$$\sigma = \frac{Q}{A}$$

Equatorial point

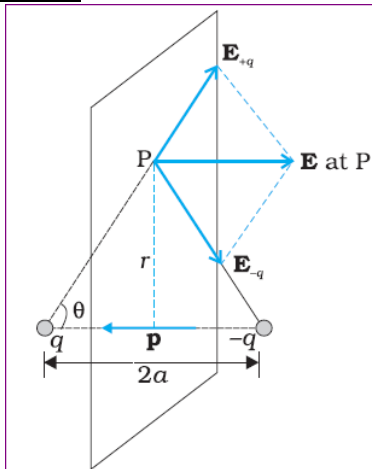

- The magnitudes of the electric fields due to the two charges +q and -q are equal and given by

$$E_{+q} = \frac{q}{4\pi\epsilon_0} \frac{1}{r^2 + a^2} \quad E_{-q} = \frac{q}{4\pi\epsilon_0} \frac{1}{r^2 + a^2}$$

- The components normal to the dipole axis cancel away.
- The components along the dipole axis add up.
- Thus total electric field is

$$\mathbf{E} = - (E_{+q} + E_{-q}) \cos \theta \hat{\mathbf{P}}$$

- Substituting $\cos \theta = \frac{a}{(r^2 + a^2)^{1/2}}$ and

simplifying we get

$$\vec{E} = \frac{-q \times 2a}{4\pi\epsilon_0 (r^2 + a^2)^{3/2}} \hat{p}$$

- For $r \gg a$, we get $\vec{E} = \frac{-q \times 2a}{4\pi\epsilon_0 r^3} \hat{p}$

- Using $p = q \times 2a$

$$\vec{E} = \frac{-p}{4\pi\epsilon_0 r^3} \hat{p}$$

Relation connecting axial field and equatorial field of dipole

- We have axial field

$$\vec{E} = \frac{1}{4\pi\epsilon_0} \left[\frac{2p}{r^3} \right] \hat{p}$$

- SI unit is C/m^2 .

Volume charge density (ρ)

- It is the charge per unit volume.

$$\rho = \frac{Q}{V}$$

- SI unit is C/m^3 .

Gauss's Theorem

- Total electric flux over a closed surface is

$$\phi = \frac{q}{\epsilon_0}$$

- Where q - total charge enclosed
- The closed surface – Gaussian surface.

Proof

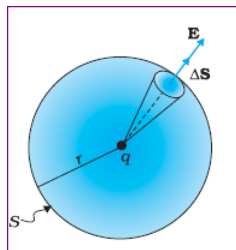

- The flux through area element ΔS is

$$\Delta\phi = \mathbf{E} \cdot \Delta \mathbf{S} = \frac{q}{4\pi\epsilon_0 r^2} \hat{\mathbf{r}} \cdot \Delta \mathbf{S} \quad \Delta\phi = \frac{q}{4\pi\epsilon_0 r^2} \Delta S$$

- The total flux through the sphere is

$$\phi = \sum_{all \Delta S} \frac{q}{4\pi\epsilon_0 r^2} \Delta S$$

$$\phi = \frac{q}{4\pi\epsilon_0 r^2} \sum_{all \Delta S} \Delta S = \frac{q}{4\pi\epsilon_0 r^2} S$$

- Where the total surface area $S = 4\pi r^2$.
- Thus

$$\phi = \frac{q}{4\pi\epsilon_0 r^2} \times 4\pi r^2 = \frac{q}{\epsilon_0}$$

Features of Gauss's law

- Gauss's law is true for any closed surface irrespective of the size and shape.
- The charge includes sum of all charges enclosed by the surface.
- Gauss's law is useful to calculate electric field when the system has some symmetry.

- Gauss's law is based on the inverse square dependence on distance contained in the Coulomb's law.

Applications of Gauss's law

Electric field due to a straight charged wire

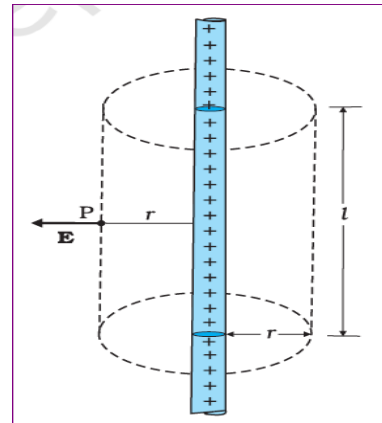

- Total flux through the Gaussian surface is $\phi = E \times 2\pi r l$
- Total charge enclosed is $q = \lambda \times l$, λ - charge per unit length
- Using Gauss's law

$$E \times 2\pi r l = \frac{\lambda l}{\epsilon_0}$$

- Thus $E = \frac{\lambda}{2\pi\epsilon_0 r}$

- In vector form $\vec{E} = \frac{\lambda}{2\pi\epsilon_0 r} \hat{n}$

- Where \hat{n} - radial unit vector

Electric field due to a plane sheet of charge

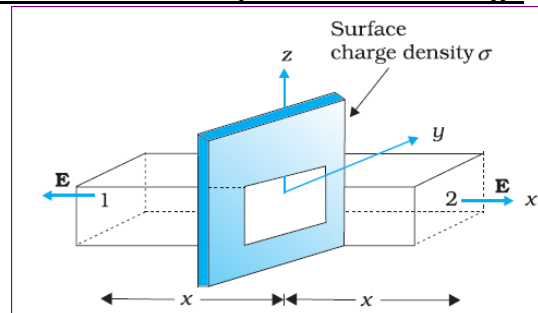

- Total flux enclosed by the Gaussian surface is $\phi = E \times (2A)$, A- area of cross section.
- Total charge enclosed is $q = \sigma A$, σ – surface charge density.

- Using Gauss's law $E \times (2A) = \frac{\sigma A}{\epsilon_0}$

- Thus $E = \frac{\sigma}{2\epsilon_0}$

- In vector form $\vec{E} = \frac{\sigma}{2\epsilon_0} \hat{n}$

- Vanishing of electric field ($E=0$) inside a charged conductor is called **electrostatic shielding**

Electric field due to a charged spherical shell

Points outside the shell

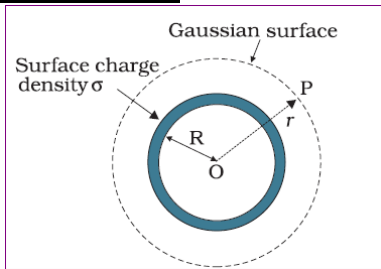

- Total flux enclosed by the Gaussian surface is $\phi = E \times (4\pi r^2)$, r- radius of Gaussian surface.
- Total charge enclosed is $q = \sigma \times (4\pi R^2)$, R -radius of shell
- Using Gauss's law

$$E \times (4\pi r^2) = \frac{\sigma \times 4\pi R^2}{\epsilon_0}$$

- Thus $E = \frac{\sigma R^2}{\epsilon_0 r^2}$

- Or $E = \frac{1}{4\pi\epsilon_0} \frac{q}{r^2}$

- In vector form $\vec{E} = \frac{1}{4\pi\epsilon_0} \frac{q}{r^2} \hat{r}$



Points on the shell

- On the surface $r=R$, therefore $E = \frac{\sigma}{\epsilon_0}$

Points inside the shell

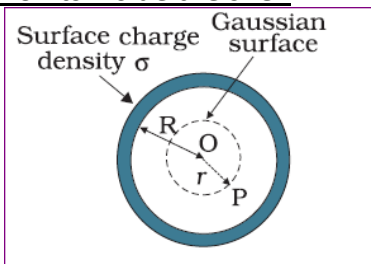

- Total charge enclosed =0
- $E \times 4\pi r^2 = 0$
- Thus $E= 0$ inside the shell.

Chapter Two

ELECTROSTATIC POTENTIAL AND CAPACITANCE

(Prepared by AYYAPPAN C, HSST, GMRHSS KASARAGOD)

ELECTROSTATIC POTENTIAL

- The electrostatic potential (V) at any point is the work done in bringing a unit positive charge from infinity to that point.

$$V = \frac{W}{q}, \text{ W - work done, q - charge.}$$

- Also $W = qV$
- It is a scalar quantity.
- Unit is J/C or volt (V)

POTENTIAL DUE TO A POINT CHARGE

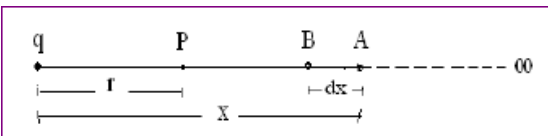

- The force acting on a unit positive charge (+1 C) at A, is

$$F = \frac{1}{4\pi\epsilon_0} \frac{q \times 1}{x^2} = \frac{1}{4\pi\epsilon_0} \frac{q}{x^2}$$

- Thus the work done to move a unit positive charge from A to B through a displacement dx is

$$dW = -\frac{1}{4\pi\epsilon_0} \frac{q}{x^2} dx$$

- The negative sign shows that the work is done against electrostatic force.
- Thus the total work done to bring unit charge from infinity to the point P is

$$W = \int_{\infty}^r dW = \int_{\infty}^r \left[-\frac{1}{4\pi\epsilon_0} \frac{q}{x^2} dx \right]$$

$$W = -\frac{q}{4\pi\epsilon_0} \int_{\infty}^r \left[\frac{1}{x^2} dx \right]$$

- Integrating

$$W = \frac{q}{4\pi\epsilon_0} \left[\frac{1}{r} - \frac{1}{\infty} \right] = \frac{q}{4\pi\epsilon_0 r}$$

- Therefore electrostatic potential is given by

$$V = \frac{1}{4\pi\epsilon_0} \frac{q}{r}$$

Variation of potential V with r

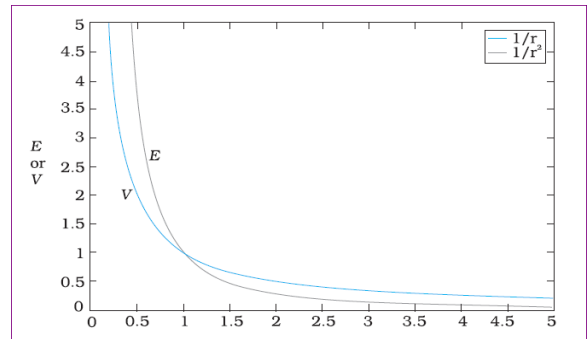

Capacitor

- It is a charge storing device.
- A capacitor is a system of two conductors separated by an insulator.

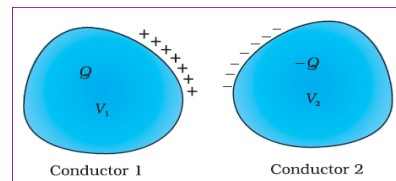

- A capacitor with large capacitance can hold large amount of charge Q at a relatively small V .

Capacitance

- The potential difference is proportional to the charge, Q .
- Thus $C = \frac{Q}{V}$
- The constant C is called the *capacitance of the capacitor*. C is independent of Q or V .
- The capacitance C depends only on the geometrical configuration (shape, size, separation) of the system of two conductors
- SI unit of capacitance is **farad**.
- Other units are, $1 \mu\text{F} = 10^{-6} \text{ F}$, $1 \text{ nF} = 10^{-9} \text{ F}$, $1 \text{ pF} = 10^{-12} \text{ F}$, etc.

Symbol of capacitor

Fixed capacitance

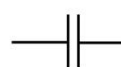

Variable capacitance





Dielectric strength

- The maximum electric field that a dielectric medium can withstand without break-down is called its dielectric strength.
- The dielectric strength of air is about $3 \times 10^6 \text{ Vm}^{-1}$.

THE PARALLEL PLATE CAPACITOR

- A parallel plate capacitor consists of two large plane parallel conducting plates separated by a small distance

Capacitance of parallel plate capacitor

- Let A be the area of each plate and d the separation between them.
- The two plates have charges Q and $-Q$.
- Plate 1 has surface charge density $\sigma = Q/A$ and plate 2 has a surface charge density $-\sigma$.

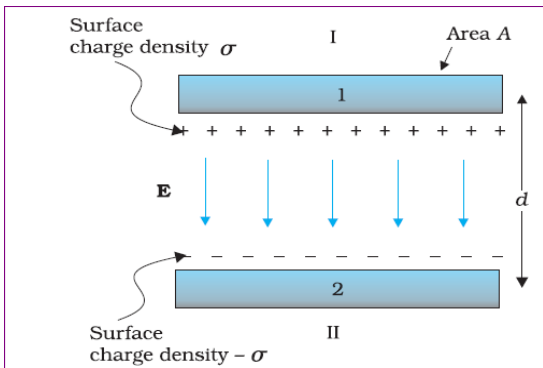

- At the region I and II, $E=0$

$$E = \frac{\sigma}{2\epsilon_0} - \frac{\sigma}{2\epsilon_0} = 0$$

- At the inner region

$$E = \frac{\sigma}{2\epsilon_0} + \frac{\sigma}{2\epsilon_0} = \frac{\sigma}{\epsilon_0} = \frac{Q}{\epsilon_0 A}$$

- The direction of electric field is from the positive to the negative plate.
- For a uniform electric field the potential difference is

$$V = E d = \frac{1}{\epsilon_0} \frac{Qd}{A}$$

- The capacitance C of the parallel plate capacitor is then

$$C = \frac{Q}{V} = \frac{\epsilon_0 A}{d}$$

- Thus $C = \frac{\epsilon_0 A}{d}$

Combination of capacitors

Capacitors in series

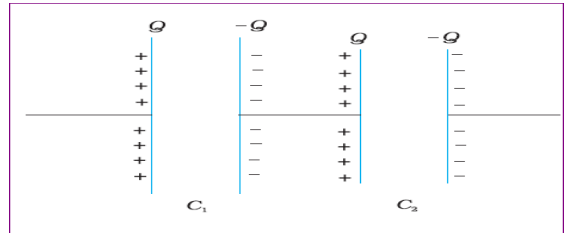

- In series charge is same and potential is different on each capacitors.
- The total potential drop V across the combination is

$$V = V_1 + V_2$$

- Considering the combination as an effective capacitor with charge Q and potential difference V , we get

$$\frac{Q}{C} = \frac{Q}{C_1} + \frac{Q}{C_2}$$

- Therefore effective capacitance is

$$\frac{1}{C} = \frac{1}{C_1} + \frac{1}{C_2}$$

- For n capacitors in series

$$\frac{1}{C} = \frac{1}{C_1} + \frac{1}{C_2} + \dots + \frac{1}{C_n}$$

Capacitors in parallel

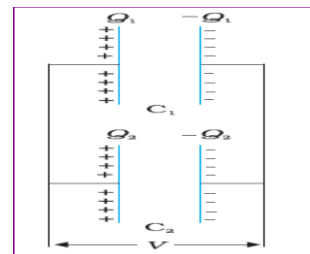

- In parallel the charge is different, potential is same on each capacitor.
- The charge on the equivalent capacitor is

$$Q = Q_1 + Q_2$$

- Thus $CV = C_1V + C_2V$

- Therefore $C = C_1 + C_2$

- In general, for n capacitors

$$C = C_1 + C_2 + \dots + C_n$$

Energy stored in a capacitor

- Energy stored in a capacitor is the **electric potential energy**.

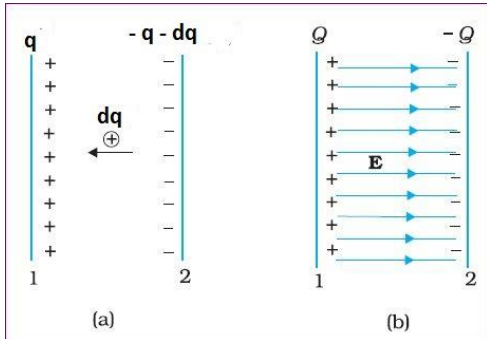

- Charges are transferred from conductor 2 to conductor 1 bit by bit, so that at the end, conductor 1 gets charge Q .
- Work done to move a charge dq from conductor 2 to conductor 1, is $dW = \text{Potential} \times \text{Charge}$
- That is $dW = \frac{q}{C} \times dq$
- Since potential at conductor 1 is, q/C .
- Thus the total work done to attain a charge Q on conductor 1, is

$$W = \int_0^Q dW = \int_0^Q \frac{q}{C} \times dq$$

- On integration we get,

$$W = \frac{1}{C} \left[\frac{q^2}{2} \right]_0^Q = \frac{Q^2}{2C}$$

- This work is stored in the form of potential energy of the system.
- Thus energy stored in the capacitor is

$$U = \frac{Q^2}{2C}$$

- Also $U = \frac{1}{2}QV$ or $U = \frac{1}{2}CV^2$

Alternate method

- We have the $Q - V$ graph of a capacitor,

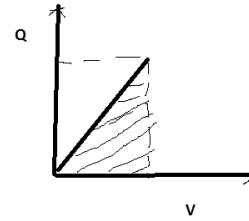

- Energy = area under the graph
- Thus, $U = \frac{1}{2} \times Q \times V$
- Also $U = \frac{1}{2}CV^2$

Energy Density of a capacitor

- Energy density is the energy stored per unit volume.

- We have $U = \frac{Q^2}{2C}$

- But $Q = \sigma A$ and $C = \frac{\epsilon_0 A}{d}$

- Thus we get $U = \frac{(\sigma A)^2}{2} \left(\frac{d}{\epsilon_0 A} \right)$

- Using $E = \frac{\sigma}{\epsilon_0}$, we get

$$U = \frac{1}{2} \epsilon_0 E^2 \times Ad$$

- Thus energy per unit volume is given by

$$\frac{U}{Ad} = \frac{1}{2} \epsilon_0 E^2$$

- That is the energy density of the capacitor is

$$u = \frac{1}{2} \epsilon_0 E^2$$



CHAPTER -3 CURRENT ELECTRICITY

*(Prepared By Ayyappan C, HSS1 Physics, GMRASS.,
Kasaragod, Mob: 9961985448)*

Ohm's law

- At constant temperature the current flowing through a conductor is directly proportional to potential difference between the ends of the conductor.
- Thus $V = IR$,
V- potential difference, I – current,
R- resistance

Resistance

- Ability of conductor to oppose electric current.

$$R = \frac{V}{I}$$

- SI unit – ohm (Ω)

Factors affecting resistance of a conductor

- Nature of material
- Proportional to length of the conductor
- Inversely proportional to area of cross section.
- Proportional to temperature

Relation connecting resistance and resistivity

$$R = \frac{\rho l}{A}$$

Where ρ - resistivity, A – area, l- length

Resistivity (specific resistance)

- Resistivity of the material of a conductor is defined as the resistance of the conductor having unit length and unit area of cross section.

$$\rho = \frac{RA}{l}$$

- Unit – ohm meter (Ωm)
- Resistivity of conductor depends on **nature of material** and **Temperature**

Conductance (G)

- Reciprocal of resistance

$$G = \frac{1}{R}$$

- Unit- Ω^{-1} , or mho or siemens (S)

Conductivity (σ)

- Reciprocal of resistivity

$$\sigma = \frac{1}{\rho}$$

- Unit- $\Omega^{-1}\text{m}^{-1}$, or mho m^{-1} , or S m^{-1}

Ohmic conductor

- A conductor which obeys ohm's law.
- Eg:- metals

V-I graph of an ohmic conductor

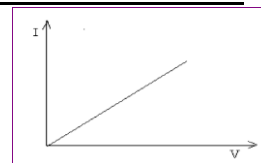

Non ohmic conductors

- Conductor which does not obey ohm's law.
- Eg :- diode, transistors, electrolytes etc.

V-I graph of a non- ohmic conductor (Diode)

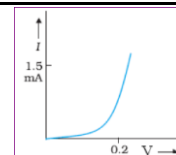

Circuit diagram for the experimental study of ohm's law

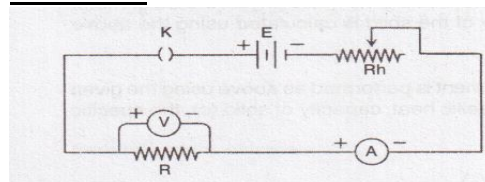

Vector form of ohm's law

- We have $V = El$
- From ohm's law, $V = IR = \frac{I\rho l}{A}$
- Thus $El = \frac{I\rho l}{A}$
- That is $E = \frac{I\rho}{A} = \rho J$
- Therefore $\vec{E} = \rho \vec{J}$ or $\vec{J} = \sigma \vec{E}$

Resistors

- The **resistor** is a passive electrical component to create resistance in the flow of electric current.

Symbol

Constant resistance



Variable resistance



Combination of resistors

Resistors in Series

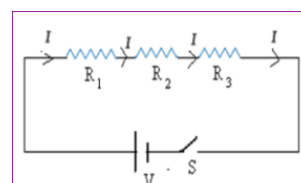

- In series connection same current pass through all resistors.
- The potential drop is different for each resistor.
- The applied potential is given by

$$V = V_1 + V_2 + V_3$$
- Where V_1 , V_2 and V_3 are the potential drop across resistors R_1 , R_2 and R_3 respectively.
- If all the resistors are replaced with a single effective resistance R_s , we get

$$V = IR_s$$
- Thus $IR_s = IR_1 + IR_2 + IR_3$
- Therefore the effective resistance is

$$R_s = R_1 + R_2 + R_3$$
- For n resistors

$$R_s = R_1 + R_2 + R_3 + \dots R_n$$
- Thus effective resistance increases in series combination.

- Thus effective resistance decreases in parallel combination.

Internal resistance of a cell (r)

- Resistance offered by the electrolytes and electrodes of a cell.

Factors affecting internal resistance

- Nature of electrolytes
- Directly proportional to the distance between electrodes
- Directly proportional to the concentration of electrolytes.
- Inversely proportional to the area of the electrodes.
- Inversely proportional to the temperature of electrolyte.

Relation connecting emf and internal resistance

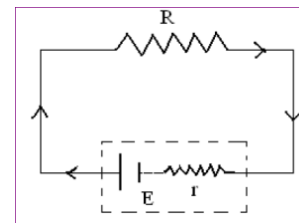

- Effective resistance = $R+r$
- Thus the current is $I = \frac{\epsilon}{R+r}$
- Where ϵ –emf, R - external resistance, r - internal resistance.
- That is $I(R+r) = \epsilon \Rightarrow IR + Ir = \epsilon$
- From ohm’s law, $V=IR$, therefore

$$r = \frac{\epsilon - V}{I}$$
- The potential is given by

$$V = \epsilon - Ir$$

Resistors in parallel

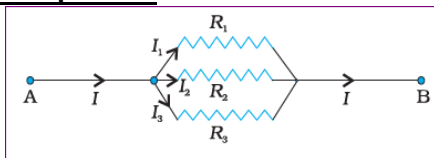

- In parallel connection current is different through each resistors.
- The potential drop is same for all resistors.
- The total current

$$I = I_1 + I_2 + I_3$$
- If all resistors are replaced with an effective resistor of resistance R_p , we get

$$I = \frac{V}{R_p}$$

- Thus

$$\frac{V}{R_p} = \frac{V}{R_1} + \frac{V}{R_2} + \frac{V}{R_3}$$

- Therefore the effective resistance in parallel combination is

$$\frac{1}{R_p} = \frac{1}{R_1} + \frac{1}{R_2} + \frac{1}{R_3}$$

- For n resistors in parallel

$$\frac{1}{R_p} = \frac{1}{R_1} + \frac{1}{R_2} + \frac{1}{R_3} + \dots + \frac{1}{R_n}$$

- For two resistors

$$R_p = \frac{R_1 R_2}{R_1 + R_2}$$

Joule’s law of heating

- The heat energy dissipated in a current flowing conductor is given by

$$H = I^2 R t$$

- I- current, R –resistance, t –time

Electric power

- It is the energy dissipated per unit time.

- Power, $P = \frac{H}{t} = I^2 R$

- Also $P = VI = \frac{V^2}{R}$

- SI unit is **watt (W)**

- 1 kilo watt (1kW) = 1000W

- 1mega watt (MW) = 10^6 W
- Another unit horse power (hp)
- 1 hp = 746 W

Electrical energy

- Electrical energy = electrical power X time
- SI unit – joule (J)
- Commercial unit – kilowatt hour (kWh)
- 1kWh = 3.6×10^6 J.

Efficiency

- The efficiency of an electrical device is

$$\eta = \frac{\text{output power}}{\text{input power}}$$

Kirchhoff's rule

First rule (junction rule or current rule)

- Algebraic sum of the current meeting at junction is zero.
- Thus , Current entering a junction = current leaving the junction

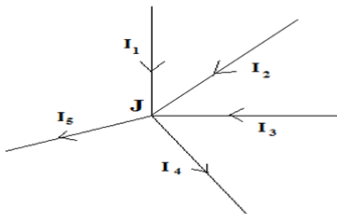

$$I_1 + I_2 + I_3 - I_4 - I_5 = 0$$

Sign convention

- Current entering the junction – positive
- Current leaving the junction - negative

Second rule (loop rule or voltage rule)

- Algebraic sum of the products of the current and resistance in a closed circuit is equal to the net emf in it.
- This rule is a statement of law of conservation of energy.

Sign convention

- Current in the direction of loop – positive
- Current opposite to loop - negative

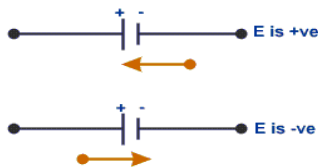

Illustration

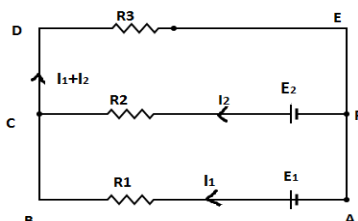

Loop ABCFA

$$I_1 R_1 - I_2 R_2 = E_1 - E_2$$

Loop CDEFC

$$I_2 R_2 + (I_1 + I_2) R_3 = E_2$$

Wheatstone's bridge

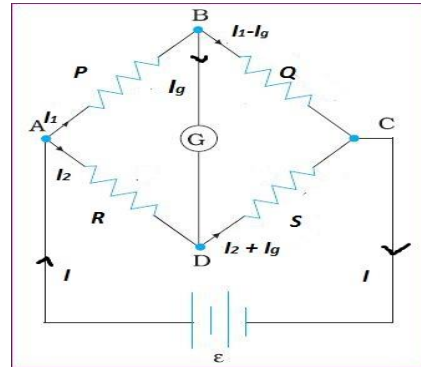

Wheatstone's principle

- If galvanometer current is zero, $\frac{P}{Q} = \frac{R}{S}$

Derivation of balancing condition

- Applying voltage rule to the loop ABDA $I_1 P + I_g G - I_2 R = 0$
- For the loop BCDB $(I_1 - I_g) Q - (I_2 + I_g) S - I_g G = 0$
- When the bridge is balanced $I_g = 0$.
- Thus $I_1 P - I_2 R = 0$ and $I_1 Q - I_2 S = 0$
- Or , $I_1 P = I_2 R$ and $I_1 Q = I_2 S$
- Thus $\frac{P}{Q} = \frac{R}{S}$
- This is the balancing condition of a Wheatstone bridge.

Meter bridge (slide wire bridge)

- Works on Wheatstone's principle.
- Used to find resistance of a wire.

Circuit diagram

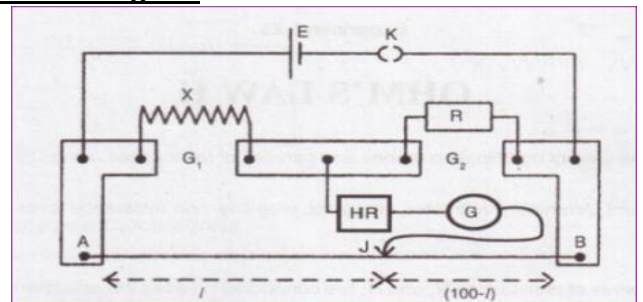

- Where k – key, X – unknown resistance, R- known resistance, HR- high resistance, G – Galvanometer, J – Jockey

Equation to find unknown resistance

- From wheatstone's principle

$$\frac{P}{Q} = \frac{R}{S}$$

- Here P – unknown resistance , Q- known resistance, R- resistance of the wire of length l , S - resistance of wire of length $(100-l)$.

- The length l for which galvanometer shows zero deflection – balancing length.

Thus

$$\frac{X}{R} = \frac{lr}{(100-l)r}$$

- Where r – resistance per unit length of the meterbridge wire.
- Therefore the unknown resistance is given by

$$X = \frac{Rl}{(100-l)}$$

- The resistivity of the resistance wire can be calculated using the formula

$$\rho = \frac{\pi r^2 X}{l}$$

Where r – radius of the wire, l –length of the wire.

Potentiometer

- A device used to measure an unknown emf or potential difference accurately.

Principle

- When a steady current (I) flows through a wire of uniform area of cross section, the potential difference between any two points of the wire is directly proportional to the length of the wire between the two points.
- From ohm's law , $V = IR$
- That is . $V = \frac{I\rho l}{A}$
- Therefore , $V \propto l$ or $V = kl$
- Thus $\frac{V}{l} = k$, where k – constant.
 $\frac{V}{l}$ – potential gradient.

Uses of potentiometer

- To compare the emf of two cells
- To find the internal resistance of a cell

Comparison of emfs

Circuit diagram

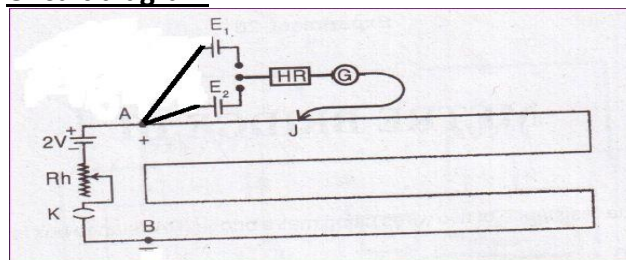

- We have, $E_1 \propto l_1$ and $E_2 \propto l_2$
- Thus $\frac{E_1}{E_2} = \frac{l_1}{l_2}$
- l_1 - balancing length with cell E_1
- l_2 - balancing length with cell E_2
- To get the balancing length $E_1 > E_2$

To find internal resistance

Circuit diagram

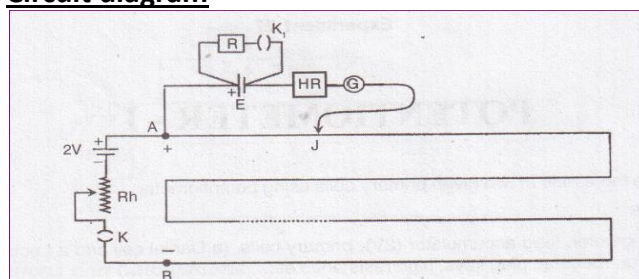

- when the key K_1 is open
 $\varepsilon \propto l_1$
- when the key K_1 is closed
 $V \propto l_2$
- Thus $\frac{\varepsilon}{V} = \frac{l_1}{l_2}$
- But we have
 $V = IR$
 $\varepsilon = I(R+r)$
 r – internal resistance
- Therefore $\frac{\varepsilon}{V} = \frac{I(R+r)}{IR} = \frac{(R+r)}{R}$
- Thus $\frac{(R+r)}{R} = \frac{l_1}{l_2}$
- The internal resistance is given by
$$r = \frac{R(l_1 - l_2)}{l_2}$$
- Where l_1 - balancing length, key K_1 open,
 l_2 - balancing length, key K_1 closed.



www.rvgirls.com

Why potentiometer is preferred over voltmeter for measuring emf of a cell?

- In potentiometer **null method** is used, so no energy loss in measurement.

CHAPTER 4

MOVING CHARGES AND MAGNETISM

(Prepared by AYYAPPAN C, HSST, GMRHSS KASARAGOD)

Magnetic Lorentz force

- Force on charge moving in a magnetic field.

$$F = qvB \sin \theta,$$
 q –charge, v - velocity,
 B – magnetic field, θ - angle between v and B .
- Or $F = q(v \times B)$

Special Cases:

- If the charge is at rest**, i.e. $v = 0$, then $F = 0$.
- Thus, a stationary charge in a magnetic field does not experience any force.
- If $\theta = 0^\circ$ or 180°** i.e. if the charge moves parallel or anti-parallel to the direction of the magnetic field, then $F = 0$.
- If $\theta = 90^\circ$** i.e. if the charge moves perpendicular to the magnetic field, then the force is maximum.

$$F_{\max} = qvB$$

Right Hand Thumb Rule

- The direction of magnetic Lorentz force can be found using right hand rule.

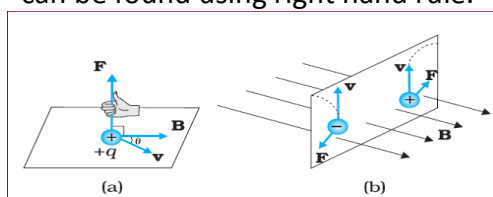

Work done by magnetic Lorentz force

- The magnetic Lorentz force is given by $F = q(v \times B)$
- Thus F , is perpendicular to v and hence perpendicular to the displacement.
- Therefore the work done $W = Fd \cos 90 = 0$
- Thus **work done by the magnetic force** on a moving charge is **zero**.
- The change in kinetic energy of a charged particle, when it is moving through a magnetic field is zero.
- The magnetic field can change the direction of velocity of a charged particle, but not its magnitude.

Lorentz force

- Force on charge moving in combined electric and magnetic field.
- $F = qE + q(v \times B) = q[E + (v \times B)]$

Units of magnetic field (magnetic induction or magnetic flux density)

- SI unit is **tesla (T)**
- Other unit is **gauss(G)**
- 1 gauss = 10^{-4} tesla**
- The earth's magnetic field is about 3.6×10^{-5} T**

Definition of Tesla

- The magnetic induction (B) in a region is said to be one tesla if the force acting on a unit charge (1C) moving perpendicular to the magnetic field (B) with a speed of 1m/s is one Newton.

Force on a current carrying wire in a magnetic field

- The total number of charge carriers in the conductor = nAl
- Where, n -number of charges per unit volume, A -area of cross section, l -length of the conductor.
- If e is the charge of each carrier, the total charge is $Q = enAl$
- The magnetic force is $F = Q(v \times B)$
- Where v – drift velocity
- Thus $F = enAl(v \times B) = nAve(l \times B)$
- Thus
$$F = I l B \sin \theta$$
- Since $I = nAve$
- When $\theta = 0$, $F = 0$
- When $\theta = 90^\circ$, $F = I l B$

Fleming's left hand rule

- A rule to find the direction of the force on a current carrying wire.

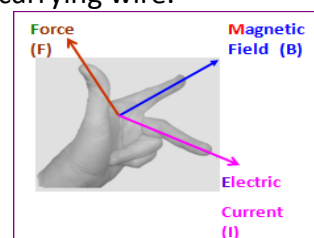

- Fore finger – direction of magnetic field
- Middle finger –direction of current
- Thumb – direction of force.



Biot-Savart Law

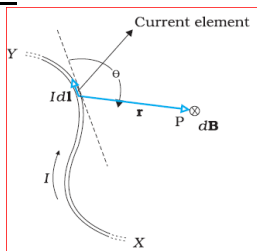

- The magnetic field at a point due to the small element of a current carrying conductor is
- directly proportional to the current flowing through the conductor (I)
- The length of the element dl
- Sine of the angle between r and dl
- And inversely proportional to the square of the distance of the point from dl.
- Thus the magnetic field due to a current element is

$$dB = \frac{\mu_0}{4\pi} \frac{Idl \sin \theta}{r^2}$$

- μ_0 -permeability of free space, I – current, r- distance
- or $dB = \frac{\mu_0}{4\pi} \frac{Id\vec{l} \times \vec{r}}{r^3}$
- where, $\frac{\mu_0}{4\pi} = 10^{-7} Tm / A$
- The direction of magnetic field is given by right hand rule.

Comparison between Coulomb's law and Biot-Savart's law

Coulomb's law	Biot – Savart's law
$F = \frac{1}{4\pi\epsilon_0\epsilon_r} \frac{q_1q_2}{r^2}$	$dB = \frac{\mu_0}{4\pi} \frac{Idl \sin \theta}{r^2}$
Electric field is due to scalar source	Magnetic field is due to vector source
Electric field is present everywhere	Along the direction of current magnetic field is zero

Applications of Biot-Savart Law

Magnetic Field on the Axis of a Circular Current Loop

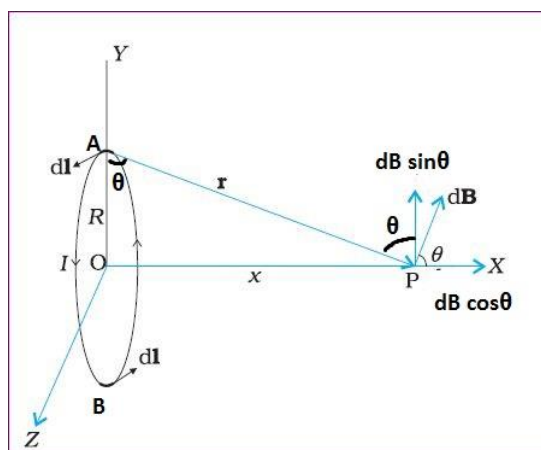

- The magnetic field at P due to the current element dl , at A is

$$dB = \frac{\mu_0}{4\pi} \frac{Idl \sin 90^\circ}{r^2} = \frac{\mu_0}{4\pi} \frac{Idl}{r^2}$$

- The component $dB \sin \theta$ is cancelled by the diametrically opposite component.
- Thus magnetic field at P ,due to the current element is the x- component of dB.

- Therefore $dB_x = dB \cos \theta$

$$dB_x = \frac{\mu_0}{4\pi} \frac{Idl}{r^2} \cos \theta$$

- But we have $r = (x^2 + R^2)^{1/2}$ and

$$\cos \theta = \frac{R}{(x^2 + R^2)^{1/2}}$$

- Therefore

$$dB_x = \frac{\mu_0}{4\pi} \frac{Idl}{(x^2 + R^2)} \frac{R}{(x^2 + R^2)^{1/2}}$$

$$dB_x = \frac{\mu_0}{4\pi} \frac{IRdl}{(x^2 + R^2)^{3/2}}$$

- The summation of the current elements dl over the loop gives , the circumference $2\pi R$.
- Thus the total magnetic field at P due to the circular coil is

$$B = \frac{\mu_0}{4\pi} \frac{IR(2\pi R)}{(x^2 + R^2)^{3/2}} = \frac{\mu_0 IR^2}{2(x^2 + R^2)^{3/2}}$$

- Therefore

$$B = \frac{\mu_0 IR^2}{2(x^2 + R^2)^{3/2}}$$

- At the centre of the loop $x=0$, thus,

$$B_0 = \frac{\mu_0 I}{2R}$$



- The direction of the magnetic field due to a circular coil is given by **right-hand thumb rule**.
- Curl the palm of your right hand around the circular wire with the fingers pointing in the direction of current. Then the right hand thumb gives the direction of magnetic field.

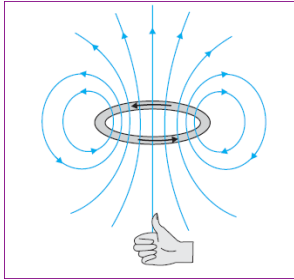

Magnetic field lines due to a circular current loop

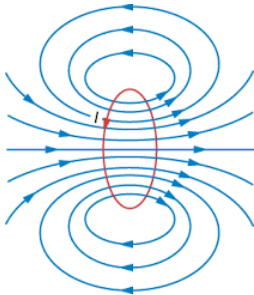

Relation Connecting Velocity of Light, Permittivity and Permeability

- We have
$$\epsilon_0 \mu_0 = \frac{4\pi\epsilon_0}{1} \left(\frac{\mu_0}{4\pi} \right) = \frac{10^{-7}}{9 \times 10^9} = \frac{1}{9 \times 10^{16}}$$
- Thus
$$\epsilon_0 \mu_0 = \frac{1}{(3 \times 10^8)^2} = \frac{1}{c^2}$$
- Where c – speed of light in vacuum.
- Therefore the speed of light is given by
$$c = \frac{1}{\sqrt{\epsilon_0 \mu_0}}$$
- In general,
$$v = \frac{1}{\sqrt{\epsilon \mu}}$$

Ampere's Circuital Law

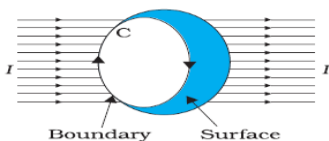

- The closed line integral of magnetic field is equal to μ_0 times the total current.
- $$\oint \mathbf{B} \cdot d\mathbf{l} = \mu_0 I$$
- The closed loop is called **Amperean Loop**.

Applications Of Ampere's Circuital Law

1. Magnetic field due to a straight wire

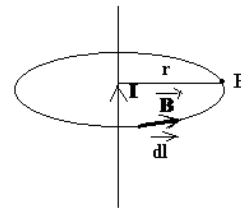

- Over the Amperian loop B and dl are along the same direction.
- Thus
$$\oint_l \mathbf{B} \cdot d\mathbf{l} = \int_l B dl \cos 0 = B \int_l dl$$
- That is
$$\int_l \mathbf{B} \cdot d\mathbf{l} = B(2\pi r)$$
- From ampere's circuital law, $B \times 2\pi r = \mu_0 I$
- Thus
$$B = \frac{\mu_0 I}{2\pi r}$$

2. Magnetic field due to a solenoid

Solenoid

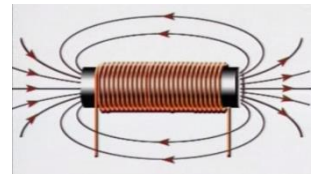

- A solenoid is an insulated copper wire closely wound in the form of a helix
- When current flows through the solenoid, it behaves as a bar magnet.
- For a long solenoid, the field outside is nearly zero.
- A solenoid is usually used to obtain a uniform magnetic field.
- If the current at one end of the solenoid is in the anticlockwise direction it will be the North Pole and if the current is in the clockwise direction it will be the South Pole.

Expression for magnetic field inside a solenoid

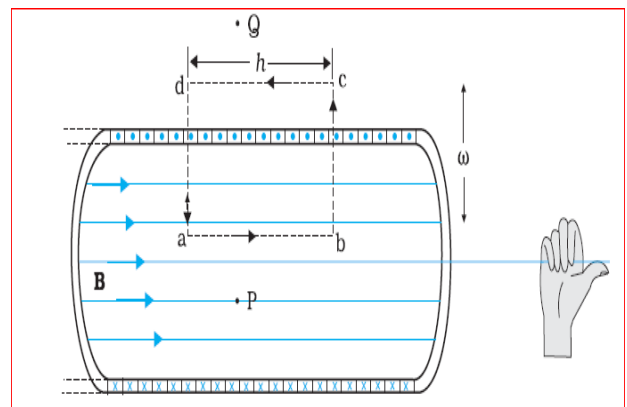

- Consider an amperian loop **abcd**
- The magnetic field is zero along cd, bc and da.
- The total number of turns of the solenoid is $N = nh$, where n – number of turns per unit length, h – length of the amperian loop.
- Therefore the total current enclosed by the loop is $I_e = nhI$,
- where, I – current in the solenoid
- Using Ampere’s circuital law

$$\oint B \cdot dl = Bh = \mu_0 I_e$$

$$Bh = \mu_0 nhI$$
- Therefore, the magnetic field inside the solenoid is

$$B = \mu_0 nI$$

- The direction of the field is given by **Right Hand Rule**.

The magnetic field due to a solenoid can be increased by

- Increasing the no. of turns per unit length (n)
- Increasing the current (I)
- Inserting a soft iron core into the solenoid.

Magnetic Field lines of a Solenoid

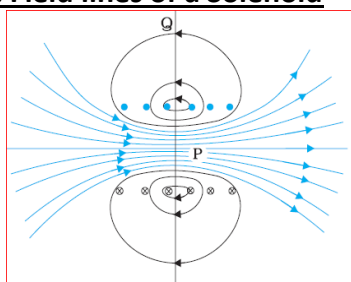

3. Magnetic Field due to a Toroid

Toroid

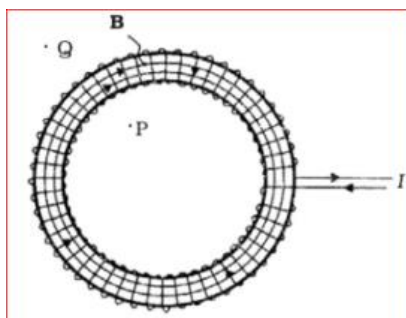

- Toroid is a hollow circular ring on which a large number of turns of a wire are closely wound.

- The magnetic field in the open space inside (point P) and exterior to the Toroid (point Q) is zero.
- The field B is constant inside the Toroid.

Magnetic Field due to a Toroid

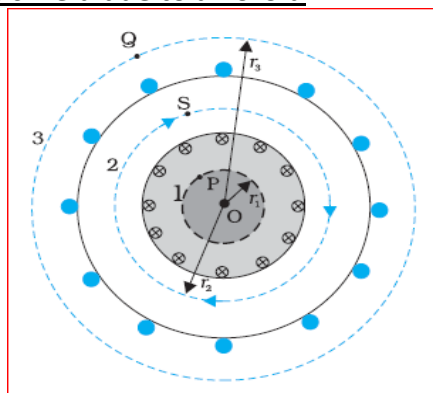

For points interior (P)

- Length of the loop 1, $L_1 = 2\pi r_1$
- The current enclosed by the loop = 0.
- Therefore

$$B_1 (2\pi r_1) = \mu_0 (0), \quad B_1 = 0$$

- Magnetic field at any point in the interior of a toroid is **zero**.

For points inside (S)

- Length of the loop, $L_2 = 2\pi r$
- The total current enclosed = $N I$, where N is the total number of turns and I the current.
- Applying Ampere’s Circuital Law and taking $r_2 = r$

$$B(2\pi r) = \mu_0 NI$$

$$B = \frac{\mu_0 NI}{2\pi r}$$

- Or

$$B = \mu_0 nI$$

- Where $n = \frac{N}{2\pi r}$



www.rvgirls.com

For points Exterior(Q)

- Each turn of the Toroid passes twice through the area enclosed by the Amperian Loop 3.
- For each turn current coming out of the plane of the paper is cancelled by the current going into the plane of paper.
- Therefore $I = 0, B = 0$.

CHAPTER 5

MAGNETISM AND MATTER

(Prepared By Ayyappan C, HSSST Physics, GMRHSS
Kasaragod)

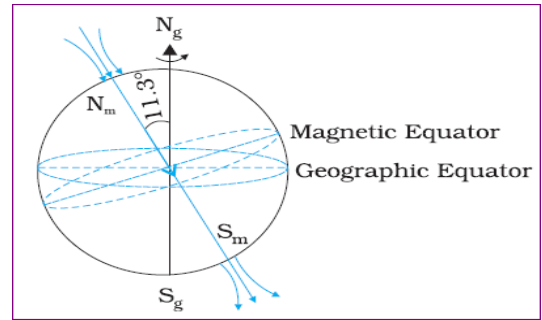

- A vertical plane passing through the magnetic axis of a freely suspended magnet is called the magnetic meridian.

Geographic Meridian

- The vertical plane passing through a place and the geographic north and south poles is called the geographic meridian at that place.

Elements of earth's magnetism

The three elements of earth's magnetic field are

- **Angle of declination (D)**
- **Angle of Dip or inclination (I)**
- **Horizontal component of earth's magnetic field (BH)**

Magnetic Declination

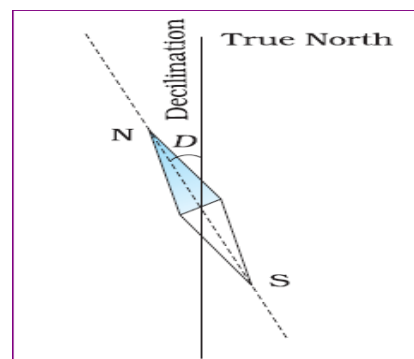

- The angle between the geographic meridian and magnetic meridian is called the angle of declination.
- The magnetic declination is different at different places on the surface of earth.
- The declination is greater at higher latitudes and smaller near the equator.

Gauss's Law in magnetism

- The law states that "the net magnetic flux through any closed surface is zero"

$$\phi_B = \sum_{\text{'all'}} \Delta\phi_B = \sum_{\text{'all'}} \mathbf{B} \cdot \Delta\mathbf{S} = 0$$

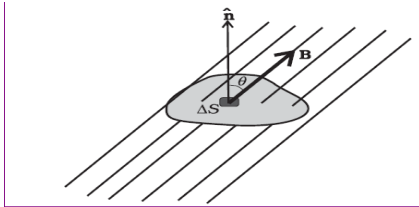

Earth's Magnetism

- Earth has an immense magnetic field surrounding it and is of the order of 10^{-5} T.
- The location of the north magnetic pole is at latitude of 79.74° N and a longitude of 71.8° W, a place somewhere in north Canada.
- The magnetic South Pole is at 79.74° S, 108.22° E in the Antarctica.

Source of Earth's Magnetism – Dynamo Effect

- Earth's magnetism is due to the electric currents produced by the convective motion of metallic fluids (consisting mostly of metallic iron and nickel) in the outer core of earth. This is known as **Dynamo Effect**.

Magnetic Meridian



- The declination in India is small, it being $0^{\circ}41'$ E at Delhi and $0^{\circ}58'$ W at Mumbai.

Dip or Inclination

- Dip is the angle that the total magnetic field B_E of the earth makes with the surface of the earth.
- The angle of dip is maximum (90 degree) at the magnetic poles and minimum (0 degree) at the magnetic equator.
- At other places its value lies between 0 degree and 90 degree.

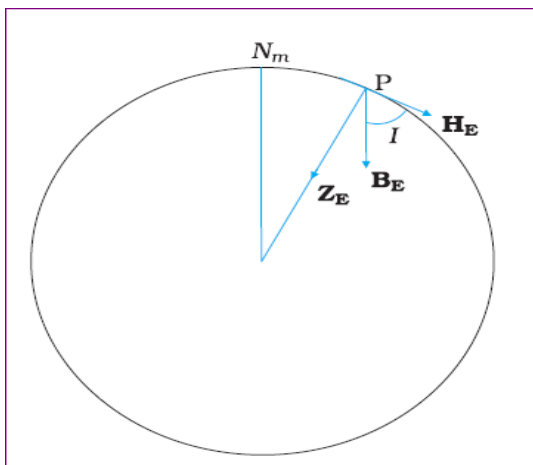

- In most of the northern hemisphere, the north pole of the dip needle tilts downwards.
- In most of the southern hemisphere, the south pole of the dip needle tilts downwards

Horizontal Component of earth's magnetic field

- The total magnetic field at P can be resolved into a horizontal component B_H and a vertical component B_V .

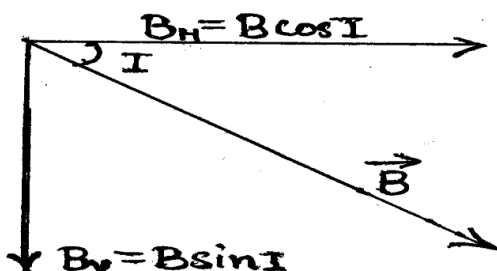

Relation Connecting Horizontal component and vertical component

- We have $B_H = B \cos I$ and $B_V = B \sin I$
- Thus $\tan I = B_V / B_H$
- Also

$$B = \sqrt{B_H^2 + B_V^2}$$

Some Important Terms

Magnetisation or Intensity of Magnetisation (M)

- Magnetisation M of a sample is the net magnetic moment per unit volume, when the sample is subjected to magnetizing field.

$$M = \frac{m_{net}}{V}$$

- M is a vector with dimensions $L^{-1}A$ and is measured in a units of $A m^{-1}$.

Magnetic Intensity or Magnetising Field (H)

- When a magnetic material is placed in a magnetic field, magnetism is induced in the material. It is known as induced magnetism.
- The field which induces magnetism in a material is called magnetizing field and the strength of that field is called magnetic intensity (H).
- Its SI unit is ampere/ metre
- The magnetizing field is given by

$$H = \frac{B}{\mu_0} - M$$

where, B – net magnetic field, M – Magnetisation, μ_0 –permeability of free space

Relation connecting B , M and H

- The total magnetic field B is written as ,
 $B = \mu_0 (H + M)$

Relation connecting M and H

- The dependence of M on H is given by $M = \chi H$, Where χ – Magnetic susceptibility

- Also $\mu_r = (1 + \chi)$

Magnetic susceptibility

- Magnetic susceptibility* is a measure of how a magnetic material responds to an external field.
- It is *small and positive* for *paramagnetic materials*
- It is *small and negative* for *diamagnetic materials*

Magnetic Flux (Φ)

- It is the number of magnetic field lines passing normally through a surface.
- The SI unit is weber(Wb)

Relation connecting B , μ and H

- We have $B = \mu_0 (H + M)$
- Substituting $M = \chi H$, we get

$$B = \mu_0 (H + \chi H) = \mu_0 H(1 + \chi),$$

$$\begin{aligned} B &= \mu_0 (1 + \chi) H \\ &= \mu_0 \mu_r H \\ &= \mu H \end{aligned}$$

- Thus
- where $\mu_r = 1 + \chi$, is a dimensionless quantity called the *relative magnetic permeability of the substance*.
- The *magnetic permeability of the substance is μ and it has the same dimensions and units as μ_0*

$$\mu = \mu_0 \mu_r = \mu_0 (1 + \chi)$$

Magnetic permeability (μ)

- It is the ratio of magnetic field to the magnetizing field

$$\mu = \frac{B}{H}$$

- Its unit is tesla meter/ampere ($Tm A^{-1}$)

Relative permeability of medium

- Relative permeability of medium is the ratio of permeability of a medium (μ) to the permeability of air or vacuum (μ_0)

$$\mu_r = \frac{\mu}{\mu_0}$$



CHAPTER 6

ELECTROMAGNETIC INDUCTION

(Prepared by AYYAPPAN C, HSST, GMRHSS KASARAGOD)

Faraday's Law of Electromagnetic Induction

- The magnitude of the induced emf in a circuit is equal to the time rate of change of magnetic flux through the circuit.

- Mathematically

$$\varepsilon = - \frac{d\Phi_B}{dt}$$

- If there are N turns

$$\varepsilon = -N \frac{d\Phi_B}{dt}$$

- The negative sign indicates the direction of emf.

Ways to increase the induced emf

- By increasing the number of turns, N.
- By changing magnetic flux.
- The magnetic flux can be varied by
 - Changing magnetic field, B
 - Changing area, A.
 - Changing the angle, θ .
 - Rotating the coil in a magnetic field.
 - Shrinking or stretching the coil in a magnetic field.

Motional Electromotive Force

- The emf induced by the motion of a conductor in a magnetic field is called motional emf.

Expression of motional emf

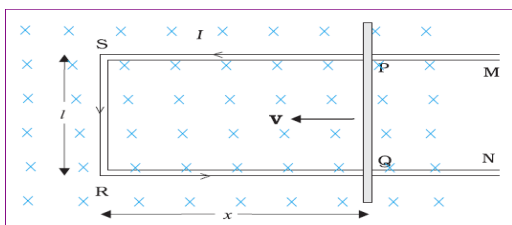

- The magnetic flux Φ_B enclosed by the loop PQRS is

$$\Phi_B = B l x, \text{ where } B - \text{magnetic field}$$

- Since x is changing with time, the rate of change of flux Φ_B will induce an emf given by

$$\begin{aligned} \varepsilon &= - \frac{d\Phi_B}{dt} = - \frac{d}{dt} (B l x) \\ &= -B l \frac{dx}{dt} = B l v \end{aligned}$$

- The induced emf $B l v$ is called motional emf.

Eddy Currents

- Eddy currents are the **surface currents** produced when **bulk pieces of conductors** are subjected to **changing magnetic field**.
- Eddy currents flow in closed loops within conductors, in planes perpendicular to the magnetic field.



- This effect was discovered by physicist Foucault, and hence this current is also known as **Foucault current**.
- The direction of eddy currents is given by Lenz's law.

Demonstration of eddy currents

Experiment 1

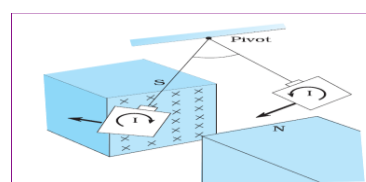

- When a copper plate is allowed to swing like a simple pendulum between the pole pieces of a strong magnet, it is found that the motion is damped and the plate comes to rest in the magnetic field.

Reason :

- As the plates moves the magnetic flux associated with it changes and eddy currents are induced on its surface.
- Directions of eddy currents are opposite when the plate swings into the region between the poles and when it swings out of the region.



- Hence the plate comes to rest.

Experiment II

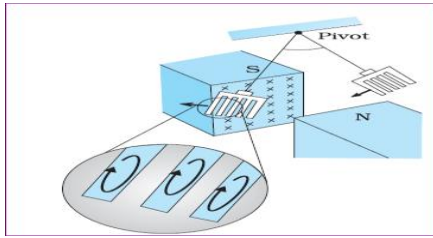

- If rectangular slots are made in the copper plate the area available to the flow of eddy currents is less.
- The pendulum plate with holes or slots reduces electromagnetic damping and the plate swings more freely.

Experiment III

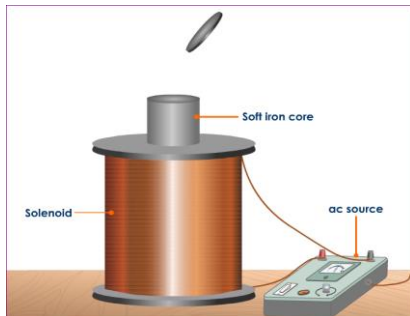

- When a metallic disc is placed on one end of a solenoid connected to an ac source and with a soft iron core in it, the disc is thrown up into air.

Reason

- The disc is subjected to a changing magnetic field and eddy currents are formed on it.
- The direction of the induced currents is as per Lenz's law and hence the disc is thrown up into air.

Disadvantages of eddy currents

- The eddy currents dissipate energy in the form of heat.
- Eddy currents are minimized by using laminations.
- Eddy currents are undesirable, in most of the electrical devices like transformer, induction coil, choke coil etc. Eddy

currents produce heating in these devices, which is wastage of energy.

Applications of Eddy currents

- Magnetic braking in trains
- Electromagnetic damping in galvanometers.
- Induction furnace
- Electric power meters
- Metal detectors
- Induction cookers
- Speedometer
- Induction motors

AC Generator

- An ac generator converts mechanical energy into electrical energy.
- Nicola Tesla is credited with the development of an ac generator.
- Modern day generators produce electric power as high as 500 MW.
- The frequency of rotation is **50 Hz** in India. In certain countries such as USA, it is **60 Hz**.

Principle/Theory

- A.C. generator works on the principle of **electro-magnetic induction**.
- The rotation of the coil causes the magnetic flux through it to change, so an emf is induced in the coil.
- When the coil is rotated with a constant angular speed ω , the angle θ between the magnetic field vector \mathbf{B} and the area vector \mathbf{A} of the coil at any instant t is $\theta = \omega t$
- The flux at any time t is

$$\Phi_B = \mathbf{BA} \cos \theta = \mathbf{BA} \cos \omega t$$

- From Faraday's law, the induced emf for the rotating coil of N turns is then,

$$\varepsilon = -N \frac{d\Phi_B}{dt} = -NBA \frac{d(\cos \omega t)}{dt}$$

- Thus, the instantaneous value of the emf is

$$\varepsilon = NBA\omega \sin \omega t$$

- where $NBA\omega$ is the **maximum value** of the emf, which occurs when $\sin \omega t = \pm 1$.
- If we denote $NBA\omega$ as ε_0 , then

$$\epsilon = \epsilon_0 \sin \omega t$$

- The direction of the current changes periodically and therefore the current is called **alternating current (ac)**.
 - Since $\omega = 2\pi v$
- $$\epsilon = \epsilon_0 \sin 2\pi v t$$
- Where v is the frequency of revolution of the generator's coil.

Construction

- An AC Generator consists of a coil mounted on a rotor shaft.
- The axis of rotation of the coil is perpendicular to the direction of the magnetic field.
- The coil (called armature) is mechanically rotated in the uniform magnetic field by some external means.
- The ends of the coil are connected to an external circuit by means of **slip rings** and brushes.

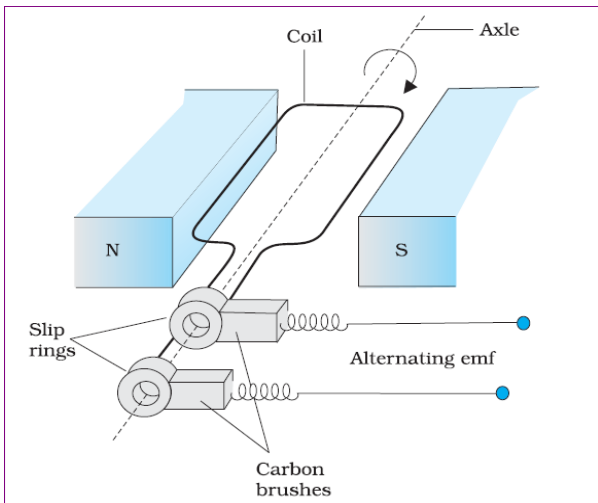

Working

- When the armature coil is mechanically rotated in a uniform magnetic field, the magnetic flux through the coil changes and hence an emf is induced in the coil.

$$\epsilon = \epsilon_0 \sin \omega t$$

- The ends of the coil are connected to external circuit by means of slip rings and brushes.

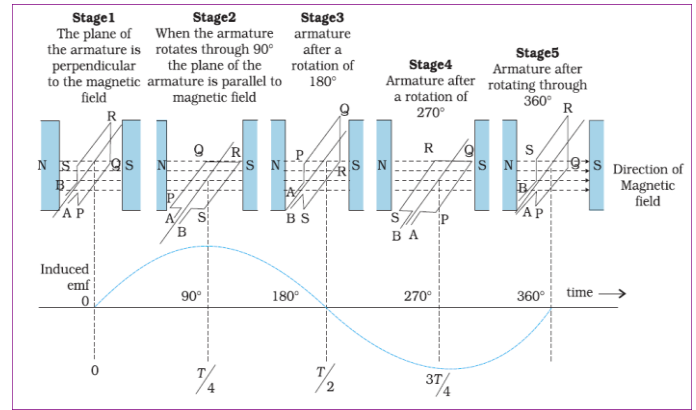

- In most generators, the coils are held stationary and it is the electromagnets which are rotated.

Hydro-electric generators.

- The mechanical energy required for rotation of the armature is provided by water falling from a height.

Thermal generators

- Water is heated to produce steam using coal or other sources.
- The steam at high pressure produces the rotation of the armature.

Nuclear power generators

- Nuclear fuel is used to heat water to produce steam.



CHAPTER 7

ALTERNATING CURRENT

(Prepared By Ayyappan C, HSST, GMRHSS Kasaragod)

AC Voltage and AC Current

- A voltage that varies like a sine function with time is called *alternating voltage (ac voltage)*.
- The electric current whose magnitude changes with time and direction reverses periodically is called the *alternating current (ac current)*.

Advantages of AC:

- Easily stepped up or stepped down using transformer
- Can be regulated using choke coil without loss of energy
- Easily converted in to dc using rectifier (Pn - diode)
- Can be transmitted over distant places
- Production of ac is more economical

Disadvantages of ac

- Cannot used for electroplating - Polarity of ac changes
- ac is more dangerous
- It can't store for longer time

Representation of ac

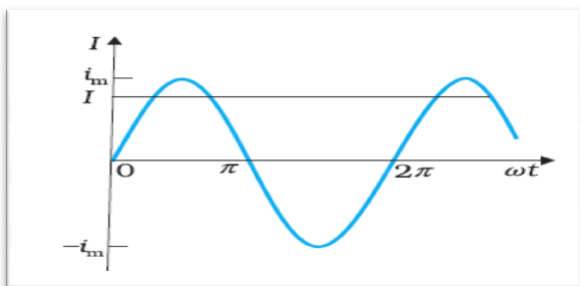

- An ac voltage can be represented as

$$v = v_m \sin \omega t$$

- v- instantaneous value of voltage ,
v_m- peak value of voltage, ω - Angular frequency.

RMS Value (effective current)

- r.m.s. value of a.c. is the d.c. equivalent which produces the same amount of heat energy in same time as that of an a.c.
- It is denoted by I_{rms} or I.
- Relation between r.m.s. value and peak value is

$$I_{rms} = \frac{i_m}{\sqrt{2}}$$

- The r.m.s voltage is given by

$$V_{rms} = \frac{v_m}{\sqrt{2}}$$

Phasors

- A phasor is a vector which rotates about the origin with angular speed ω.
- The vertical components of phasors V and I represent the sinusoidally varying quantities v and i.
- The magnitudes of phasors V and I represent the peak values v_m and i_m

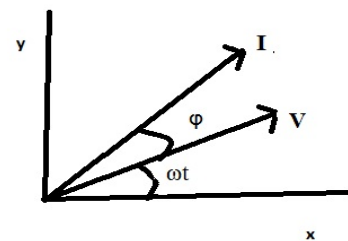

- The diagram representing alternating voltage and current (phasors) as the rotating vectors along with the phase angle between them is called phasor diagram.

AC Voltage applied to a Resistor

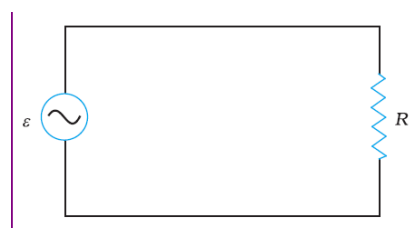

- The ac voltage applied to the resistor is

$$v = v_m \sin \omega t$$

- Applying Kirchoff's loop rule

$$v_m \sin \omega t = iR$$

$$i = \frac{v_m}{R} \sin \omega t$$



- Since R is a constant, we can write this equation as

$$i = i_m \sin \omega t$$

- Where peak value of current is

$$i_m = \frac{v_m}{R}$$

- Thus when ac is passed through a resistor the voltage and current are in phase with each other.

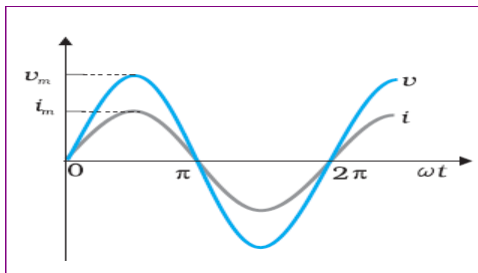

Phasor diagram

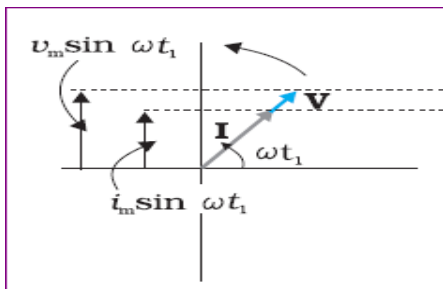

Instantaneous power

- The instantaneous power dissipated in the resistor is

$$p = i^2 R = i_m^2 R \sin^2 \omega t$$

Average power

- The average value of p over a cycle is

$$\bar{p} = \langle i^2 R \rangle = \langle i_m^2 R \sin^2 \omega t \rangle$$

or

$$\bar{p} = i_m^2 R \langle \sin^2 \omega t \rangle$$

- Using the trigonometric identity,

$$\sin^2 \omega t = 1/2 (1 - \cos 2\omega t)$$

$$\langle \sin^2 \omega t \rangle = (1/2) (1 - \langle \cos 2\omega t \rangle)$$

- Since $\langle \cos 2\omega t \rangle = 0$

$$\langle \sin^2 \omega t \rangle = \frac{1}{2}$$

- Thus

$$\bar{p} = \frac{1}{2} i_m^2 R$$

- In terms of r.m.s value

$$P = \bar{p} = \frac{1}{2} i_m^2 R = I^2 R$$

- Or

$$P = V^2 / R = IV \quad (\text{since } V = IR)$$

AC VOLTAGE APPLIED TO AN INDUCTOR

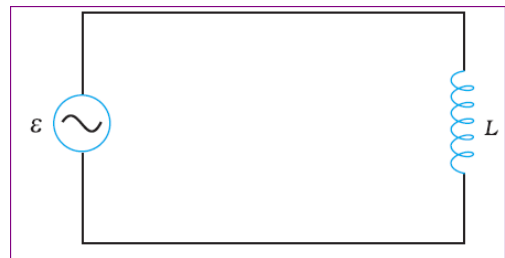

- Let the voltage across the source be

$$v = v_m \sin \omega t$$

- Using the Kirchoff's loop rule

$$v - L \frac{di}{dt} = 0$$

- Where L is the self-inductance

- Thus

$$\frac{di}{dt} = \frac{v}{L} = \frac{v_m}{L} \sin \omega t$$

- Integrating

$$\int \frac{di}{dt} dt = \frac{v_m}{L} \int \sin(\omega t) dt$$

$$i = -\frac{v_m}{\omega L} \cos(\omega t) + \text{constant}$$

- Since the current is oscillating, the constant of integration is zero.
- Using

$$-\cos(\omega t) = \sin\left(\omega t - \frac{\pi}{2}\right)$$

$$i = i_m \sin\left(\omega t - \frac{\pi}{2}\right)$$

- Where

$$i_m = \frac{v_m}{\omega L}$$

- Or

$$i_m = \frac{v_m}{X_L}$$

- Where X_L - inductive reactance

Inductive reactance (X_L)

- The resistance offered by the inductor to an ac through it is called inductive reactance.
- It is given by

$$X_L = \omega L$$

- The dimension of inductive reactance is the same as that of resistance and its SI unit is ohm (Ω).
- The inductive reactance is directly proportional to the inductance and to the frequency of the current.

Phasor Diagram

- We have the source voltage

$$v = v_m \sin \omega t$$

- The current

$$i = i_m \sin\left(\omega t - \frac{\pi}{2}\right)$$

- Thus a comparison of equations for the source voltage and the current in an inductor shows that the current lags the voltage by $\pi/2$ or one-quarter (1/4) cycle.

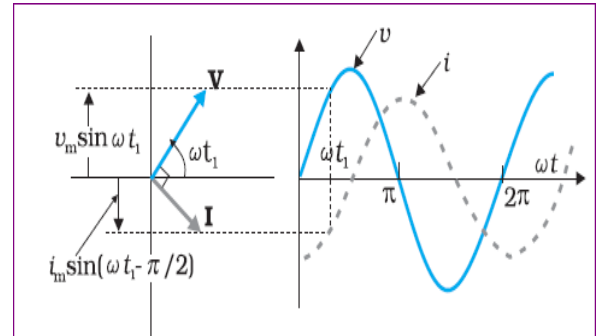

Instantaneous power

- The instantaneous power supplied to the inductor is

$$\begin{aligned} p_L &= i v = i_m \sin\left(\omega t - \frac{\pi}{2}\right) \times v_m \sin(\omega t) \\ &= -i_m v_m \cos(\omega t) \sin(\omega t) \\ &= -\frac{i_m v_m}{2} \sin(2\omega t) \end{aligned}$$

Average power

- The average power over a complete cycle in an inductor is

$$\begin{aligned} P_L &= \left\langle -\frac{i_m v_m}{2} \sin(2\omega t) \right\rangle \\ &= -\frac{i_m v_m}{2} \langle \sin(2\omega t) \rangle = 0, \end{aligned}$$

- since the average of $\sin(2\omega t)$ over a complete cycle is zero.
- Thus, the *average power supplied to an inductor over one complete cycle is zero.*



AC VOLTAGE APPLIED TO A CAPACITOR

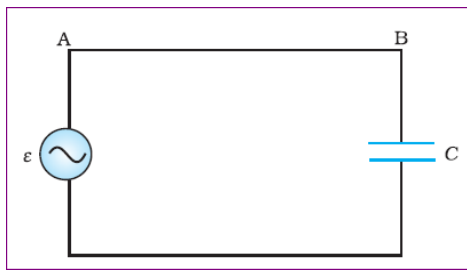

- A capacitor in a dc circuit will limit or oppose the current as it charges.
- When the capacitor is connected to an ac source, it limits or regulates the current, but does not completely prevent the flow of charge.
- Let the applied voltage be

$$v = v_m \sin \omega t$$

- The instantaneous voltage v across the capacitor is

$$v = \frac{q}{C}$$

- Where q is the charge on the capacitor.
- Using the Kirchhoff's loop rule

$$v_m \sin \omega t = \frac{q}{C}$$

- Therefore

$$i = \frac{d}{dt}(v_m C \sin \omega t) = \omega C v_m \cos(\omega t)$$

- Using the relation

$$\cos(\omega t) = \sin\left(\omega t + \frac{\pi}{2}\right)$$

$$i = i_m \sin\left(\omega t + \frac{\pi}{2}\right)$$

- Where

$$i_m = \frac{v_m}{(1 / \omega C)}$$

- Or

$$i_m = \frac{v_m}{X_C}$$

- Where X_C – capacitive reactance

Capacitive Reactance

- It is the resistance offered by the capacitor to an ac current through it.
- The dimension of capacitive reactance is the same as that of resistance and its SI unit is ohm (Ω).

Phasor Diagram

- The applied voltage is

$$v = v_m \sin \omega t$$

- The current is

$$i = i_m \sin\left(\omega t + \frac{\pi}{2}\right)$$

- Thus the current leads voltage by $\pi/2$.

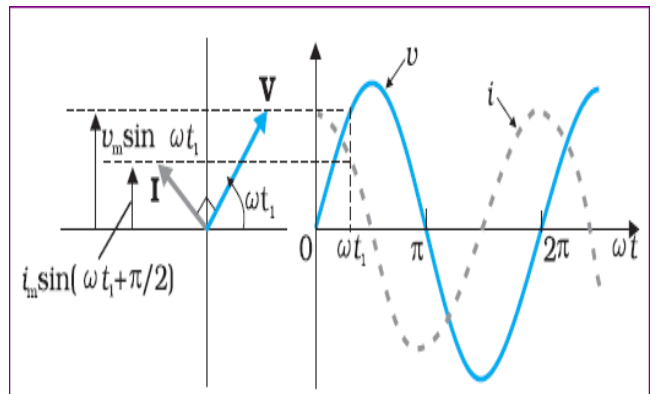

Instantaneous power

- The instantaneous power supplied to the capacitor is

$$p_c = i v = i_m \cos(\omega t) v_m \sin(\omega t) = i_m v_m \cos(\omega t) \sin(\omega t) = \frac{i_m v_m}{2} \sin(2\omega t)$$

Average power

- The average power is given by



$$P_C = \left\langle \frac{i_m v_m}{2} \sin(2\omega t) \right\rangle = \frac{i_m v_m}{2} \langle \sin(2\omega t) \rangle = 0$$

- Thus the average power over a cycle when an ac passed through a capacitor is zero.

TRANSFORMER

- It is a device used to change alternating voltage.
- It works using the principle of mutual induction.
- Works only in ac

Construction

- A transformer consists of two sets of coils, insulated from each other.
- They are wound on a soft-iron core, either one on top of the other.
- One of the coils called the **primary coil** has N_p turns.
- The other coil is called the **secondary coil**; it has N_s turns.
- The primary coil is the **input coil** and the secondary coil is the **output coil** of the transformer.

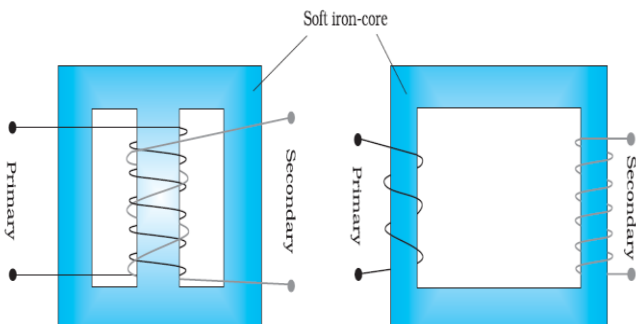

Theory / Transformer Equation

- Let ϕ be the flux in each turn in the core at time t due to current in the primary when a voltage v_p is applied to it.
- The induced emf or voltage ϵ_s in the secondary with N_s turns is

$$\epsilon_s = -N_s \frac{d\phi}{dt}$$

- The alternating flux ϕ also induces an emf, called back emf in the primary.

$$\epsilon_p = -N_p \frac{d\phi}{dt}$$

- Assuming

$$\epsilon_p = v_p \text{ and } \epsilon_s = v_s$$

- Therefore

$$v_s = -N_s \frac{d\phi}{dt}$$

$$v_p = -N_p \frac{d\phi}{dt}$$

- Thus

$$\frac{v_s}{v_p} = \frac{N_s}{N_p}$$

- For an ideal transformer input power and output power are equal, therefore

$$i_p v_p = i_s v_s$$

- Thus

$$\frac{i_p}{i_s} = \frac{v_s}{v_p} = \frac{N_s}{N_p}$$

- This is the transformer equation.

Types of Transformers

Step-up transformer

- We have

$$V_s = \left(\frac{N_s}{N_p}\right) V_p \text{ and } I_s = \left(\frac{N_p}{N_s}\right) I_p$$

- Thus, if the secondary coil has a greater number of turns than the primary ($N_s > N_p$), **the voltage is stepped up** ($V_s > V_p$). This type of arrangement is called a **step-up transformer**.
- In step up transformer, there is less current in the secondary than in the primary ($I_s < I_p$)

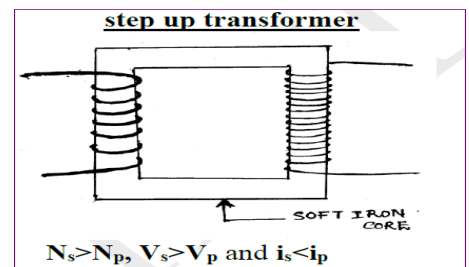

Step-down transformer

- In a step-down transformer the secondary coil has less turns than the primary ($N_s < N_p$).
- Here $V_s < V_p$ and $I_s > I_p$. That is, the voltage is stepped down, or reduced, and the current is increased.

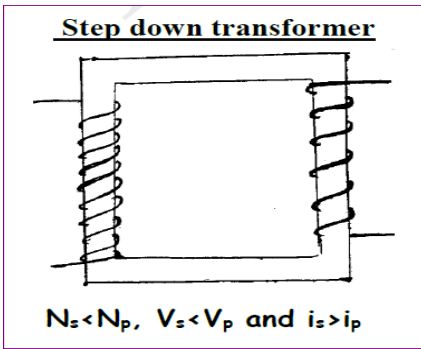

Working

- When an alternating voltage is applied to the primary, the resulting current produces an alternating magnetic flux which links the secondary and induces an emf in it.
- The value of the emf depends on the number of turns in the secondary.

Efficiency of a transformer

- The efficiency of a transformer is given by

$$\text{Efficiency, } \eta = \frac{\text{output power}}{\text{input power}}$$

Energy loss in transformers

Copper Loss

- As the current flows through the primary and secondary copper wires, electric energy is wasted in the form of heat.
- This is minimised by using thick wire.

Eddy current Loss (Iron Loss)

- The eddy currents produced in the soft iron core of the transformer produce heating.
- Thus electric energy is wasted in the form of heat.
- The effect is reduced by having a laminated core.

Magnetic flux leakage

- The entire magnetic flux produced by the primary coil may not be available to the secondary coil.
- Thus some energy is wasted.
- It can be reduced by winding the primary and secondary coils one over the other.

Hysteresis Loss

- Since the soft iron core is subjected to continuous cycles of magnetization, the core gets heated due to hysteresis.

- Minimised by using a magnetic material which has a low hysteresis loss.

Uses of a transformer

- The large scale transmission and distribution of electrical energy over long distances is done with the use of transformers.
- The voltage output of the generator is stepped-up. It is then transmitted over long distances to an area sub-station near the consumers. There the voltage is stepped down.
- It is further stepped down at distributing sub-stations and utility poles before a power supply of 240 V reaches our homes.



**CHAPTER 8****ELECTROMAGNETIC WAVES**

(Prepared By Ayyappan C, HSS7 Physics, MRRHSS
Kasaragod, Mob: 9961985448)

INTRODUCTION

- Electromagnetic waves are one of the predictions of Maxwell's equations.
- Electromagnetic waves are time varying electric and magnetic fields that propagate in space.
- **Hertz** experimentally confirmed the existence of electromagnetic waves with the help of **spark gap oscillator**.
- **J C Bose** produced electromagnetic waves of smaller wavelength (5mm-25mm).
- **Marconi** discovered that electromagnetic wave can radiate up to several kilometers.

DISPLACEMENT CURRENT

- From Maxwell's correction to Ampere's circuital law, the total current i is the sum of the conduction current denoted by i_c and the displacement current denoted by i_d .

$$i = i_e + i_d = i_c + \epsilon_0 \frac{d\Phi_E}{dt}$$

$$I_d = \epsilon_0 \frac{d\phi_E}{dt}$$

- The current due to changing electric field (or electric displacement) is called **displacement current or Maxwell's displacement current**.
- The current carried by conductors due to flow of charges is called **conduction current**.
- Thus the generalized Ampere's circuital law (Ampere-Maxwell law) is given by

$$\oint \mathbf{B} \cdot d\mathbf{l} = \mu_0 i_c + \mu_0 \epsilon_0 \frac{d\Phi_E}{dt}$$

Nature of electromagnetic waves

- An electric charge oscillating with a frequency produces em waves of the same frequency.

- The electric and magnetic fields in an electromagnetic wave are perpendicular to each other, and to the direction of propagation.

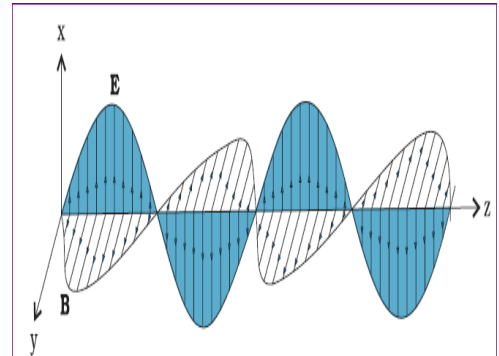

- The electric and magnetic fields are represented by

$$E_x = E_0 \sin(kz - \omega t)$$

$$B_y = B_0 \sin(kz - \omega t)$$

- Here k is related to the wave length λ of the wave by the equation,

$$k = \frac{2\pi}{\lambda}$$

- The speed of propagation of the wave is (ω/k) .
- The magnitude of the electric and the magnetic fields in an electromagnetic wave are related as

$$B_0 = (E_0/c)$$

- Pressure exerted by em wave is called **radiation pressure**

Properties of EM waves

- They are self-sustaining oscillations of electric and magnetic fields in free space, or vacuum.
- Shows transverse wave nature.
- No material medium is needed for its propagation.
- EM waves are not deflected in electric field and magnetic field.
- The velocity of em waves in any media is given by

$$v = \frac{1}{\sqrt{\mu\epsilon}}$$

- EM waves are polarised.

- Electromagnetic waves carry energy and momentum like other waves.
- If the total energy transferred to a surface in time t is U , the magnitude of the total momentum delivered to this surface (for complete absorption) is,

$$P = \frac{U}{c}$$

ELECTROMAGNETIC SPECTRUM

- An arrangement of electromagnetic radiations according to their wavelength or frequency.
- Some of the waves in the **increasing order of frequency (decreasing order of wavelength)** are :

Radio waves, microwaves, infra-red, visible light, ultra violet, x-rays, Gamma rays

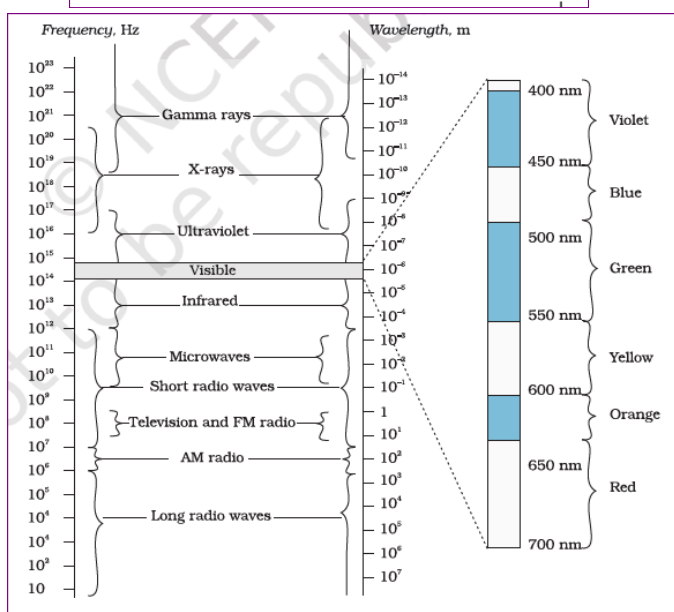
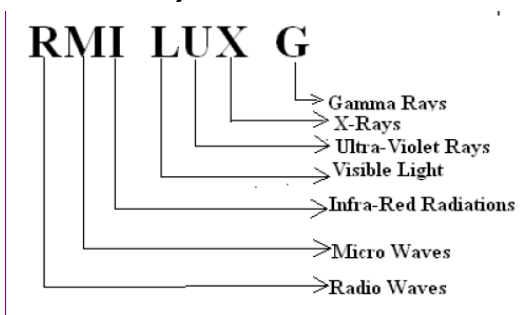

Radio waves

- Radio waves are produced by the accelerated motion of charges in conducting wires.

- They are used in radio and television communication systems.
- They are generally in the frequency range from 500 kHz to about 1000 MHz.
- The AM (amplitude modulated) band is from 530 kHz to 1710 kHz.
- Higher frequencies up to 54 MHz are used for *short wave bands*. TV waves range from 54 MHz to 890 MHz.
- The FM (frequency modulated) radio band extends from 88 MHz to 108 MHz.
- Cellular phones use radio waves to transmit voice communication in the ultrahigh frequency (UHF) band.

Microwaves

- Microwaves are produced by special vacuum tubes such as klystrons, magnetrons and Gunn diodes.
- Microwaves are used for the radar systems used in aircraft navigation. Radar also provides the basis for the speed guns used to time fast balls, tennis serves, and automobiles.
- Used in Microwave ovens.
- In such ovens, the frequency of the microwaves is selected to match the resonant frequency of water molecules so that energy from the waves is transferred efficiently to the kinetic energy of the molecules. This raises the temperature of any food containing water.
- Also used in satellite communication.

Infrared waves

- Infrared waves are produced by hot bodies and molecules.
- Infrared waves are referred to as *heat waves*. This is because water molecules present in most materials readily absorb infrared waves (many other molecules, for example, CO₂, NH₃, also absorb infrared waves). After absorption, their thermal motion increases, that is, they heat up and heat their surroundings.



- Infrared radiation plays an role in maintaining the earth's warmth or average temperature through the **greenhouse effect**.
- Incoming visible light is absorbed by the earth's surface and reradiated as infrared radiations. This radiation is trapped by greenhouse gases such as carbon dioxide and water vapour.
- Infrared detectors are used in Earth satellites, both for military purposes and to observe growth of crops.
- Electronic devices (for example semiconductor light emitting diodes) also emit infrared and are widely used in the remote switches of household electronic systems such as TV sets, video recorders and hi-fi systems.
- Used in secret signaling and burglar alarms.
- Used in the treatment of dislocations, paralysis etc.
- Used to take the photographs of distant objects.
- Used in physiotherapy
- Used for determination of molecular structure.
- The sun is an important source of ultraviolet light. But most of it is absorbed in the ozone layer in the atmosphere at an altitude of about 40 – 50 km.
- UV light in large quantities has harmful effects on humans. Exposure to UV radiation induces the production of more melanin, causing tanning of the skin.
- UV radiation is absorbed by ordinary glass. Hence, one cannot get tanned or sunburn through glass windows.
- Welders wear special glass goggles or face masks with glass windows to protect their eyes from large amount of UV produced by welding arcs.
- Due to its shorter wavelengths, UV radiations can be focused into very narrow beams for high precision applications such as **LASIK** (*Laser assisted in situ keratomileusis*) eye surgery.
- *UV lamps are used to kill germs* in water purifiers.
- Ozone layer in the atmosphere plays a protective role.
- Used in the manufacture of fluorescent tubes
- Used in the determination of age of written documents
- Used in the detection of finger prints.
- Helps to produce vitamin D in our skin.

Visible rays

- It is the part of the spectrum that is detected by the human eye.
- It runs from about a wavelength range of about 700 – 400 nm.
- Visible light emitted or reflected from objects around us provides us information about the world. Our eyes are sensitive to this range of wavelengths.
- Different animals are sensitive to different range of wavelengths. For example, snakes can detect infrared waves, and the 'visible' range of many insects extends well into the ultraviolet.

Ultraviolet rays

- Ultraviolet (UV) radiation is produced by special lamps and very hot bodies

X-rays

- Beyond the UV region of the electromagnetic spectrum lies the X-ray region.
- W Roentgen discovered x-rays
- One common way to generate X-rays is to bombard a metal target by high energy electrons.
- X-rays are used as a diagnostic tool in medicine and as a treatment for certain forms of cancer.
- Because X-rays damage or destroy living tissues and organisms, care must be taken to avoid unnecessary or over exposure.

- Used to study structure of atoms molecules and crystals
- Used to detect cracks and holes inside a sheet of metal.
- Used to detect hidden materials.

Gamma rays

- They lie in the upper frequency range of the electromagnetic spectrum.
- This high frequency radiation is produced in nuclear reactions and also emitted by radioactive nuclei.
- They are used in medicine to destroy cancer cells.
- Used to study structure of nuclei of atom.
- Used to sterilize surgical Instruments,
- Used to detect cracks in underground metal pipes etc

Production and detection of em waves

Type	Wavelength range	Production	Detection
Radio	> 0.1 m	Rapid acceleration and decelerations of electrons in aerials	Receiver's aerials
Microwave	0.1m to 1 mm	Klystron valve or magnetron valve	Point contact diodes
Infra-red	1mm to 700 nm	Vibration of atoms and molecules	Thermopiles Bolometer, Infrared photographic film
Light	700 nm to 400 nm	Electrons in atoms emit light when they move from one energy level to a lower energy level	The eye Photocells Photographic film
Ultraviolet	400 nm to 1nm	Inner shell electrons in atoms moving from one energy level to a lower level	Photocells Photographic film
X-rays	1nm to 10 ⁻³ nm	X-ray tubes or inner shell electrons	Photographic film Geiger tubes Ionisation chamber
Gamma rays	<10 ⁻³ nm	Radioactive decay of the nucleus	-do-



CHAPTER 9**RAY OPTICS AND OPTICAL INSTRUMENTS**

(Prepared By Ayyappan C, HSST Physics, GMRHSS, Kasaragod, Mob: 9961985448)

REFLECTION OF LIGHT

- When light is incident on a surface, it partially reflected back, partly absorbed by the surface and remaining is transmitted through the surface.
- Mirrors are used to reflect light efficiently.

Ray of Light

- The path along which a light wave travels is called ray of light.

Beam of Light

- A bundle of ray of light is called beam of light.

Angle of incidence

- The angle between the incident ray and the normal is the angle of incidence.

Angle of reflection

- The angle between the reflected ray and the normal is the angle of reflection

Spherical Mirrors

- The portion of a reflecting surface, which forms a part of a sphere, is called a spherical mirror.
- **Concave mirror** – reflecting surface towards the centre of the sphere
- **Convex mirror** – reflecting surface away from the centre of the sphere.

Some definitions**Centre of curvature (C)**

- The centre of the sphere of which the mirror forms a part.

Radius of curvature (R)

- The radius of the sphere of which the mirror forms a part.

Pole

- The geometric centre of a spherical mirror is called its pole.

Principal Axis

- The line joining the pole and centre of curvature.

Aperture

- The diameter of the mirror.

Principal Focus

- The point at which, a narrow beam of light incident on the mirror parallel to its principal axis, after reflection from the mirror, meets or appears to come from.

Focal length

- The distance between pole and principal focus.

Spherical aberration

- The inability of a spherical mirror of large aperture to focus the marginal rays and central rays at a single point is called spherical aberration.

Cartesian Sign Convention

- According to this convention, all distances are measured from the pole of the mirror or the optical centre of the lens.
- The distances measured in the same direction as the incident light are taken as positive and those measured in the direction opposite to the direction of incident light are taken as negative.
- The heights measured upwards with respect to x-axis and normal to the principal axis (x-axis) of the mirror/ lens are taken as positive).
- The heights measured downwards are taken as negative.



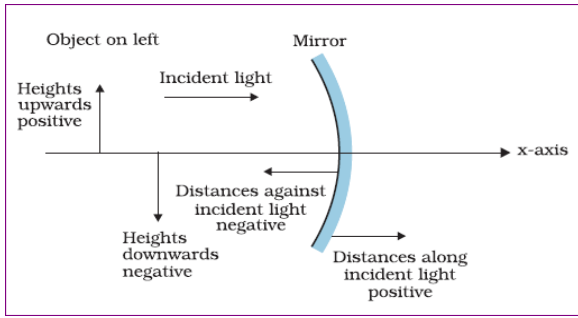

$$\frac{MD}{FD} = 2 \frac{MD}{CD}$$

$$\text{or, } FD = \frac{CD}{2}$$

- For small θ , the point D is very close to the point P.
- Therefore, $FD = f$ and $CD = R$.

$$f = R/2$$

Reflection of light by spherical mirrors

Concave mirror

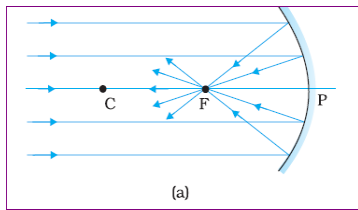

Covex Mirror

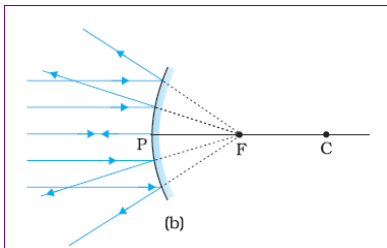

Some conventions to draw a ray diagram

- The ray from the point which is parallel to the principal axis. The reflected ray goes through the focus of the mirror.
- The ray passing through the centre of curvature of a concave mirror or appearing to pass through it for a convex mirror. The reflected ray simply retraces the path.
- The ray passing through (or directed towards) the focus of the concave mirror or appearing to pass through (or directed towards) the focus of a convex mirror. The reflected ray is parallel to the principal axis.
- The ray incident at any angle at the pole. The reflected ray follows laws of reflection.

Relation between focal length and radius of curvature of a spherical mirror

- Consider a ray parallel to the principal axis striking the mirror at M.

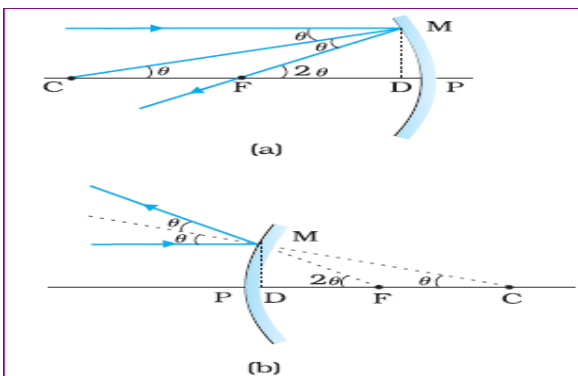

- Thus from the diagram

$$\angle MCP = \theta \text{ and } \angle MFP = 2\theta$$

Now,

$$\tan \theta = \frac{MD}{CD} \text{ and } \tan 2\theta = \frac{MD}{FD}$$

- For small θ , $\tan \theta \approx \theta$, $\tan 2\theta \approx 2\theta$.

The mirror equation

- The relation connecting the object distance (u), image distance (v) and the focal length (f) is the mirror equation.

Derivation

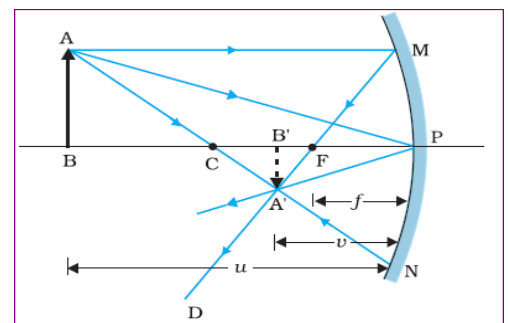

- In the diagram the two right-angled triangles $A'B'F$ and MPF are similar.

- Therefore,

$$\frac{B'A'}{PM} = \frac{B'F}{FP}$$

or $\frac{B'A'}{BA} = \frac{B'F}{FP}$ ($\because PM = AB$)

- Since $\angle APB = \angle A'PB'$, the right angled triangles $A'B'P$ and ABP are also similar.
- Therefore,

$$\frac{B'A'}{BA} = \frac{B'P}{BP}$$

- Comparing Equations :

$$\frac{B'F}{FP} = \frac{B'P - FP}{FP} = \frac{B'P}{BP}$$

- Using sign conventions

$$B'P = -v, FP = -f, BP = -u$$

- We get

$$\frac{-v+f}{-f} = \frac{-v}{-u}$$

or $\frac{v-f}{f} = \frac{v}{u}$

- Therefore the mirror equation is given by

$$\frac{1}{v} + \frac{1}{u} = \frac{1}{f}$$

- The same equation can be derived for a convex mirror too.

Linear Magnification

- Linear magnification (m) is the ratio of the height of the image (h') to the height of the object (h).

$$m = \frac{h'}{h}$$

- In triangles $A'B'P$ and ABP , we have,

$$\frac{B'A'}{BA} = \frac{B'P}{BP}$$

- With the sign convention, this becomes

$$\frac{-h'}{h} = \frac{-v}{-u}$$

so that

$$m = \frac{h'}{h} = -\frac{v}{u}$$

- Therefore the linear magnification is given by

$$m = -\frac{v}{u}$$

- The expression for magnification is same for concave and convex mirror.

Significance of magnification 'm'

- When 'm' is positive, the image is erect (virtual)
- When 'm' is negative, the image is inverted (real)
- For enlarged image, $m > 1$
- For diminished image, $m < 1$

Uses of spherical mirrors

Concave mirrors

- Used as reflectors of table lamps to direct light in a given area.
- Concave mirrors of large aperture are used in reflecting type astronomical telescopes.
- Shaving mirrors are made slightly concave to get erect enlarged image of the face.

Convex mirrors

- They are used in automobiles as rear view mirrors because of the two reasons:
- A convex mirror always produces an erect image.
- The image is diminished in size, so that it gives a wide field of view.

Nature of the image formed by a Concave mirror

Object position	Image position	Size of image	Nature of image
At infinity	Focus (F)	Point sized	Real
Beyond C	Between F and C	Small	Real and inverted
At C	At C	Same as that of the object	Real and inverted
Between C and F	Behind C	Enlarged	Real and inverted
At F	At infinity	Highly enlarged	Real and inverted
Between F and P	Behind mirror	Enlarged	Virtual and erect

Nature of the image formed by a Convex mirror

- A convex mirror always forms a virtual and diminished image irrespective of the position of the object

REFRACTION OF LIGHT

- The phenomenon of change in path of light as it goes from one medium to another is called **refraction**.

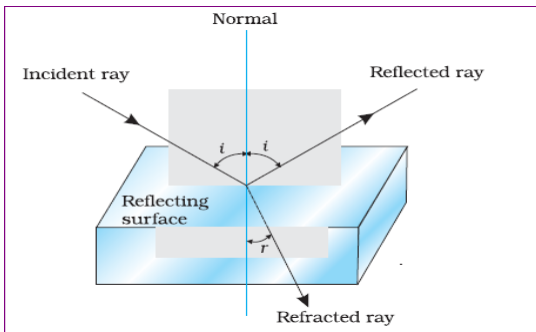

Laws of Refraction

- The incident ray, the refracted ray and the normal to the interface at the point of incidence, all lie in the same plane.

Snell's law:-

- The ratio of the sine of the angle of incidence to the sine of angle of refraction is constant.
- Now

$$\frac{\sin i}{\sin r} = n_{21}$$

- Where n_{21} is a constant, called the **refractive index** of the second medium with respect to the first medium.

$$n_{21} = \frac{n_2}{n_1}$$

- Where n_1 - absolute refractive index of the first medium and n_2 – absolute refractive index of the second medium.

Refractive index

- The refractive index of a medium depends on
 - Nature of the pair of medium
 - Wavelength of light
- Refractive index is independent of the angle of incidence.
- A medium having **larger value of refractive index** is called **optically denser** medium.
- A medium having **smaller value of refractive index** is called **optically rarer** medium.
- Also

$$n_{12} = \frac{1}{n_{21}}$$

- Where $n_{12} = \frac{n_1}{n_2}$
- If n_{32} is the refractive index of medium 3 with respect to medium 2 then

$$n_{32} = n_{31} \times n_{12}$$
- Where n_{31} is the refractive index of medium 3 with respect to medium 1.

Absolute refractive index

- The ratio of velocity of light in vacuum to the velocity of light in a medium is called absolute refractive index.

$$n = \frac{c}{v}$$

- Where C - velocity of light in vacuum, v- velocity of light in the medium.
- When **light enters from a rarer medium to denser medium**, the refracted ray **bends towards the normal**.
- When **light enters from a denser medium to rarer medium**, the refracted ray **bends away from the normal**.

$n_{\text{air}} = 1$	$n_{\text{glass}} = 1.5$
$n_{\text{water}} = 1.33$	$n_{\text{diamond}} = 2.42$



Refraction through a glass slab - Lateral shift

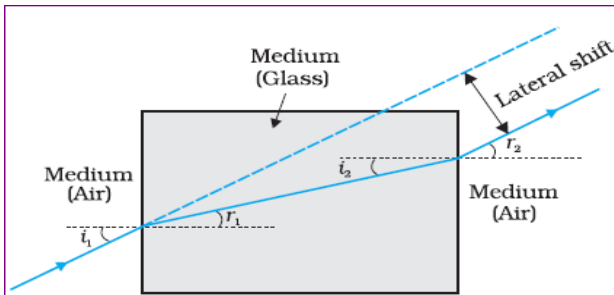

- For a rectangular slab, refraction takes place at two interfaces (air-glass and glass-air).
- When a light ray enters a glass slab it undergoes lateral displacement/ shift with respect to the incident ray.
- The perpendicular distance between the incident ray and the emergent ray, when the light is incident obliquely on a parallel sided refracting slab is called **lateral shift**.

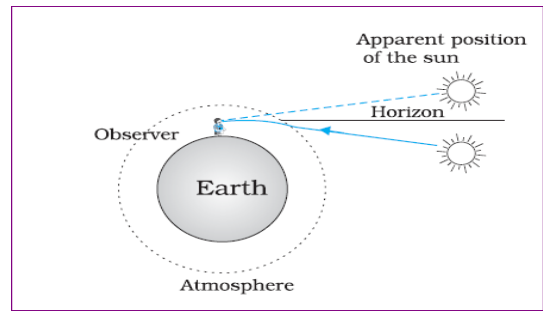

- As we go up, the density of air in the atmosphere continuously decreases, and thus the light coming from the sun undergoes refraction.
- Thus we see the sun at an apparent position raised above the horizon.
- This is the reason for early sunrise and delayed sunset.

Applications of refraction

Apparent depth

- If an object in a denser medium is viewed from a rarer medium the image appears to be raised towards the surface.
- The bottom of a tank filled with water appears to be raised due to refraction.

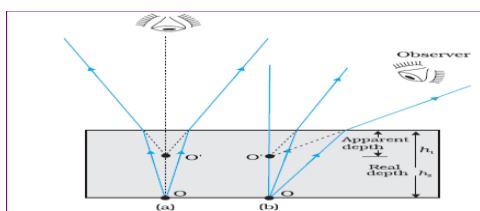

- For viewing near the normal direction

$$\text{Apparent Depth} = \frac{\text{Real Depth}}{\text{Refractive Index}}$$

Apparent position of sun

- The sun is visible a little before the actual sunrise and until a little after the actual sunset due to refraction of light through the atmosphere.
- Time difference between actual sunset and apparent sunset is about 2 minutes.

Twinkling of stars



- The light rays coming from the sun undergo refraction and hence the star is viewed at the apparent position.
- As the density of air in the atmosphere continuously changes, the apparent position also changes continuously.
- Thus the star appears to be twinkling.

REFRACTION AT SPHERICAL SURFACES

Expression for refraction at a convex surface

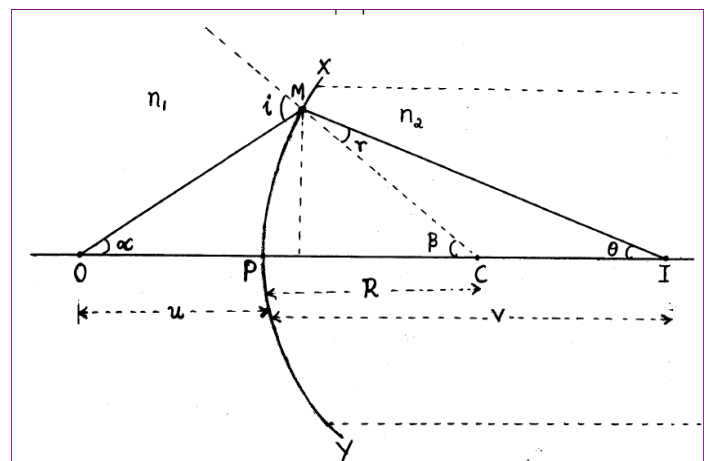

- For small angles, $\tan \theta \approx \theta$, thus

- From triangle OMP,

$$\tan\alpha \approx \alpha = \frac{PM}{PO}$$

- From triangle PCM,

$$\tan\beta \approx \beta = \frac{PM}{PC}$$

- From triangle PMI,

$$\tan\theta \approx \theta = \frac{PM}{PI}$$

- From triangle OMC,
Exterior angle = sum of interior angles
- Thus

$$\begin{aligned} i &= \alpha + \beta \\ &= \frac{PM}{PO} + \frac{PM}{PC} \dots\dots\dots(1) \end{aligned}$$

- From triangle IMC

$$\begin{aligned} \beta &= r + \theta \\ \Rightarrow r &= \beta - \theta \\ &= \frac{PM}{PC} - \frac{PM}{PI} \dots\dots\dots(2) \end{aligned}$$

- By Snell's law

$$\frac{\sin i}{\sin r} = \frac{n_2}{n_1}$$

- If i and r are small,

$$\frac{i}{r} = \frac{n_2}{n_1}$$

$$n_1 i = n_2 r$$

- Substituting for i and r ,

$$n_1 \left(\frac{PM}{PO} + \frac{PM}{PC} \right) = n_2 \left(\frac{PM}{PC} - \frac{PM}{PI} \right)$$

- Or

$$n_1 \frac{PM}{PO} + n_1 \frac{PM}{PC} = n_2 \frac{PM}{PC} - n_2 \frac{PM}{PI}$$

- Thus

$$\frac{n_1}{PO} + \frac{n_1}{PC} = \frac{n_2}{PC} - \frac{n_2}{PI}$$

- Therefore

$$\frac{n_1}{PO} + \frac{n_2}{PI} = \frac{n_2 - n_1}{PC} \dots\dots\dots(3)$$

- By Cartesian sign convention
 $PO = -u, PI = v, PC = R$

- Thus equation(3) becomes

$$\frac{n_2}{v} - \frac{n_1}{u} = \frac{n_2 - n_1}{R}$$

- This is the **equation of refraction at convex surface.**

Refraction by a lens - Lens maker's formula

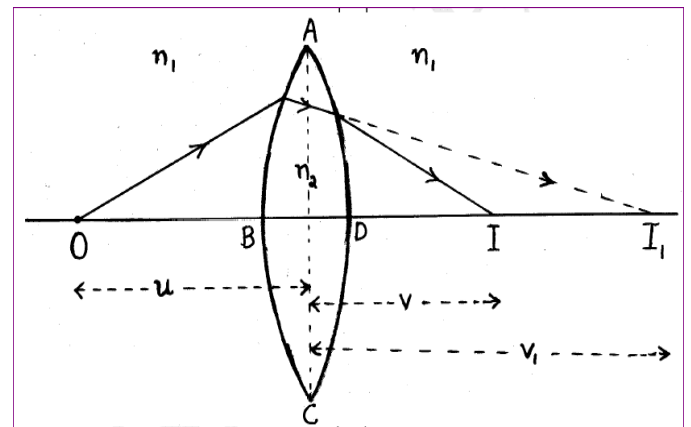

- The image formation has two steps:
 - The first refracting surface forms the image I_1 of the object O .
 - The image formed by the first refracting surface acts as the virtual object for the second refracting surface and the final image is formed at I .
- We have the curved surface formula

$$\frac{n_2}{v} - \frac{n_1}{u} = \frac{n_2 - n_1}{R}$$

For refraction at the surface ABC

- Light ray travels from n_1 to n_2 and O is the object and I_1 is the image.
- And

$$v \rightarrow v_1, R \rightarrow R_1$$

- Here R_1 is the radius of curvature of ABC .

- Thus

$$\frac{n_2}{v_1} - \frac{n_1}{u} = \frac{n_2 - n_1}{R_1} \dots\dots\dots (1)$$

For refraction at the surface ADC

- Light ray travels from n_2 to n_1 .
- Here I_1 is the object and I is the image and

$$n_1 \leftrightarrow n_2, u \rightarrow v_1, v \rightarrow v, R_1 \rightarrow R_2$$

- Here R_2 is the radius of curvature of ADC

$$\therefore \frac{n_1}{v} - \frac{n_2}{v_1} = \frac{n_1 - n_2}{R_2} \dots\dots\dots (2)$$

$$\frac{n_1}{v} - \frac{n_2}{v_1} = \frac{-(n_2 - n_1)}{R_2} \dots\dots\dots (3)$$

- Adding equation 1 and 2, we get

$$\frac{n_1}{v} - \frac{n_1}{u} = (n_2 - n_1) \left[\frac{1}{R_1} - \frac{1}{R_2} \right]$$

- Dividing by n_1

$$\frac{1}{v} - \frac{1}{u} = \left(\frac{n_2 - n_1}{n_1} \right) \left[\frac{1}{R_1} - \frac{1}{R_2} \right]$$

$$\frac{1}{v} - \frac{1}{u} = \left(\frac{n_2}{n_1} - 1 \right) \left[\frac{1}{R_1} - \frac{1}{R_2} \right]$$

$$\frac{1}{v} - \frac{1}{u} = (n_{21} - 1) \left[\frac{1}{R_1} - \frac{1}{R_2} \right] \dots\dots\dots (4)$$

- If the object is at infinity, the image is formed at the principal focus.
- Thus if $u = \infty, v = f$, equation 4 becomes

$$\frac{1}{f} - \frac{1}{\infty} = (n_{21} - 1) \left[\frac{1}{R_1} - \frac{1}{R_2} \right]$$

- Thus the **lens maker's formula** is given by

$$\therefore \frac{1}{f} = (n_{21} - 1) \left[\frac{1}{R_1} - \frac{1}{R_2} \right] \dots\dots\dots (5)$$

Thin lens formula

- We have from eqn 4,

$$\frac{1}{v} - \frac{1}{u} = (n_{21} - 1) \left[\frac{1}{R_1} - \frac{1}{R_2} \right]$$

- And the lens maker's formula

$$\therefore \frac{1}{f} = (n_{21} - 1) \left[\frac{1}{R_1} - \frac{1}{R_2} \right]$$

- If the first medium is air $n_1 = 1$ and ,let $n_2 = n$, then

$$n_{21} = \frac{n_2}{n_1} = n$$

- Thus

$$\frac{1}{f} = (n - 1) \left[\frac{1}{R_1} - \frac{1}{R_2} \right]$$

- Therefore

$$\frac{1}{v} - \frac{1}{u} = \frac{1}{f}$$

- This equation is the **thin lens formula**.
- The formula is valid for both convex as well as concave lenses and for both real and virtual images.

Linear magnification of a lens

- Magnification (m) produced by a lens is defined, as the ratio of the size of the image to that of the object.

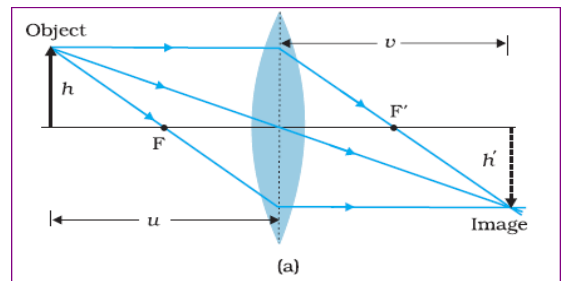

$$m = \frac{h'}{h} = \frac{v}{u}$$

- The value of m is negative for real images and positive for virtual images.

Power of a lens

- Power of a lens is the reciprocal of focal length expressed in metre.
- Power of a lens is a measure of the convergence or divergence, which a lens introduces in the light falling on it.

$$P = \frac{1}{f}$$

- The SI unit for power of a lens is dioptr (D).

- Power of a lens is positive for a converging lens and negative for a diverging lens.

Combination of thin lenses in contact

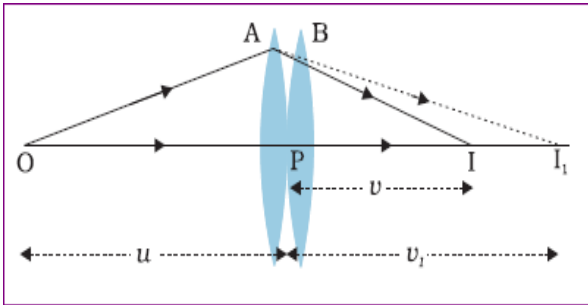

- For the first lens, object is at O and image is at I₁.

$$u \rightarrow u, v \rightarrow v_1, f \rightarrow f_1$$

- Thus

$$\frac{1}{v_1} - \frac{1}{u} = \frac{1}{f_1}$$

- For the second lens object is I₁ and image is at I.

$$u \rightarrow v_1, v \rightarrow v, f \rightarrow f_2$$

- Therefore

$$\frac{1}{v} - \frac{1}{v_1} = \frac{1}{f_2}$$

- Adding Equations

$$\frac{1}{v} - \frac{1}{u} = \frac{1}{f_1} + \frac{1}{f_2}$$

- If the two lens-system is regarded as equivalent to a single lens of focal length *f*, we have

$$\frac{1}{v} - \frac{1}{u} = \frac{1}{f}$$

- Therefore

$$\frac{1}{f} = \frac{1}{f_1} + \frac{1}{f_2}$$

- If several thin lenses of focal length *f*₁, *f*₂, *f*₃... are in contact, the effective focal length of their combination is given by

$$\frac{1}{f} = \frac{1}{f_1} + \frac{1}{f_2} + \frac{1}{f_3} + \dots$$

- Thus the power is given by

$$P = P_1 + P_2 + P_3 + \dots$$

- The total magnification

$$m = m_1 m_2 m_3 \dots$$

REFRACTION THROUGH A PRISM

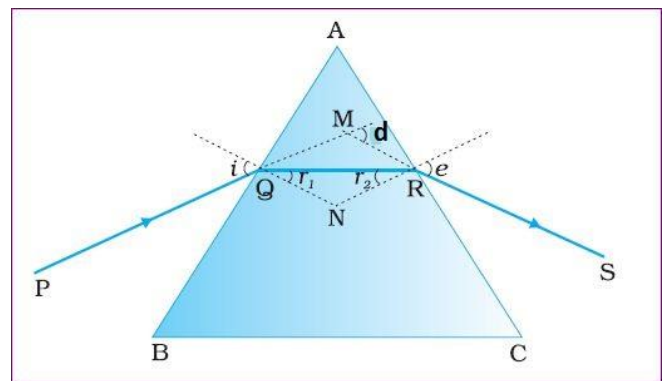

Angle of deviation, (d)

- The angle between the emergent ray RS and the direction of the incident ray PQ is called the *angle of deviation*, δ.

Angle of minimum deviation (D)

- The angle of deviation for which the refracted ray inside the prism becomes parallel to its base is called angle of minimum deviation.

Prism Formula (Eqn. for refractive index)

- In the quadrilateral AQNR, two of the angles (at the vertices Q and R) are right angles.
- Therefore, the sum of the other angles of the quadrilateral is 180°.

$$\angle A + \angle QNR = 180^\circ$$

- From the triangle QNR

$$r_1 + r_2 + \angle QNR = 180^\circ$$

- Comparing these two equations

$$r_1 + r_2 = A$$

- We know, exterior angle = sum of interior angles, thus

$$d = (i - r_1) + (e - r_2)$$

- That is

$$d = (i + e - A)$$

- Thus, the angle of deviation depends on the angle of incidence.
- At the minimum deviation, $d=D$, $i=e$, $r_1=r_2$, therefore

$$2r = A \text{ or } r = \frac{A}{2}$$

$$D = 2i - A, \text{ or } i = (A + D) / 2$$

- Thus using Snell's law, the refractive index of the prism is given by

$$n_{21} = \frac{\sin \frac{(A + D)}{2}}{\sin \frac{A}{2}}$$

Prism formula for a small angled prism

- For a small angled prism

$$n_{21} = \frac{(A + D)}{A}$$

- Therefore

$$D = (n_{21} - 1)A$$

i-d curve

- It is the plot between the angle of deviation and angle of incidence.

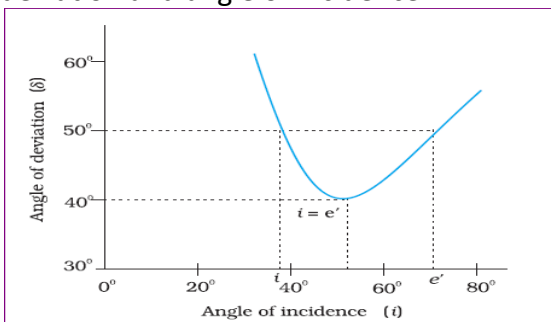

DISPERSION BY A PRISM

- The phenomenon of splitting of light into its component colours is known as *dispersion*.

- The pattern of colour components of light is called the spectrum of light.

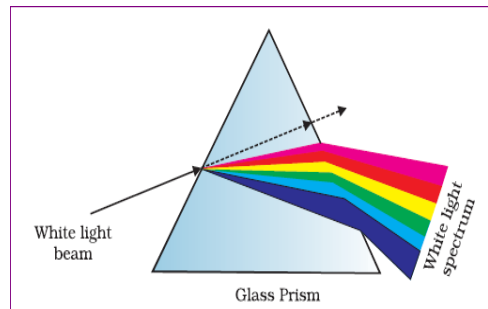

- Thick lenses could be assumed as made of many prisms, therefore, thick lenses show **chromatic aberration** due to dispersion of light.
- When white light is passed through a prism, it splits into its seven component colors (**VIBGYOR**).
- If we place a second prism in an inverted position, close to the first prism, the second prism recombines the colors and we get white light.

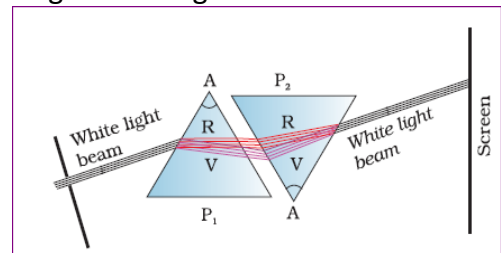

Cause of dispersion

- Dispersion takes place because the refractive index of medium for different wavelengths (colors) is different.

Dispersive medium

- The medium in which the different colours of light travel with different velocities is called a dispersive medium.
- Eg :- Glass

Non-Dispersive medium

- The medium in which all colours travel with the same speed is called non-dispersive medium.
- Eg:- vacuum

Chromatic aberration

- The inability of a lens to focus all wavelength to a single point is called chromatic aberration.

Chapter Ten

WAVE OPTICS

(Prepared by AYYAPPAN C, HSST, GMRHSS KASARAGOD)

Wavefront

- A wavefront is locus of all points in a medium which are at the same phase of vibration.
- The speed with which the wavefront moves outwards from the source is called the speed of the wave.
- The energy of the wave travels in a direction perpendicular to the wavefront.

Types of wavefront

- **Spherical wavefront** – wavefront from a point source

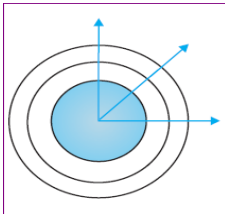

- **Cylindrical wavefront**- wavefront from a linear source.

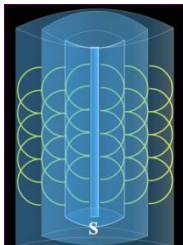

- **Plane wavefront** : - wavefront at large distances from a point source.

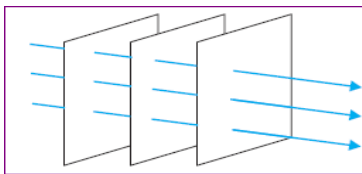

Huygen's Principle

- According to Huygens principle, *each point of the wavefront is the source of a secondary disturbance and the wavelets (secondary wavelets) emanating from these points spread out in all directions with the speed of the wave.*

- *By drawing a common tangent to all these spheres, we obtain the new position of the wavefront at a later time.*

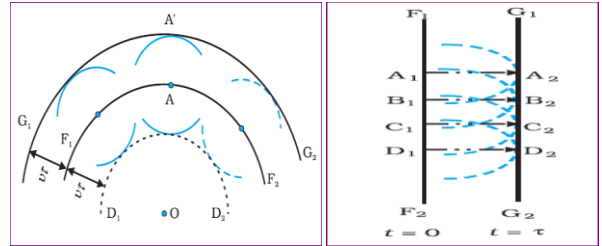

- Huygens argued that the amplitude of the secondary wavelets is maximum in the forward direction and zero in the backward direction

Refraction of a plane wave

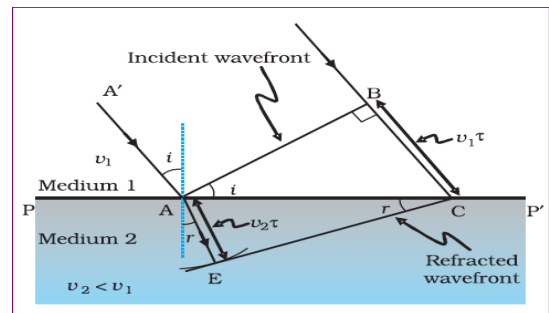

- Let τ be the time taken by the wavefront to travel the distance BC.

• Thus $BC = v_1 \tau$

- From the triangle ABC we get

$$\sin i = \frac{BC}{AC} = \frac{v_1 \tau}{AC}$$

- Also from triangle AEC

$$\sin r = \frac{AE}{AC} = \frac{v_2 \tau}{AC}$$

- Thus

$$\frac{\sin i}{\sin r} = \frac{v_1}{v_2}$$

- If c represents the speed of light in vacuum, then,

$$n_1 = \frac{c}{v_1} \quad n_2 = \frac{c}{v_2}$$

- Therefore

$$n_1 \sin i = n_2 \sin r$$

- This is the **Snell's law of refraction.**
- If λ_1 and λ_2 denote the wavelengths of light in medium 1 and medium 2, respectively, then



$$\frac{\lambda_1}{\lambda_2} = \frac{BC}{AE} = \frac{v_1}{v_2}$$

- That is

$$\frac{v_1}{\lambda_1} = \frac{v_2}{\lambda_2}$$

- This implies that **when a wave gets refracted into a denser medium, the wavelength and the speed of propagation decrease but the frequency $\nu (=v/\lambda)$ remains the same.**

- Therefore the angles i and r would be equal. This is the *law of reflection*.

A plane wave passing through a thin prism.

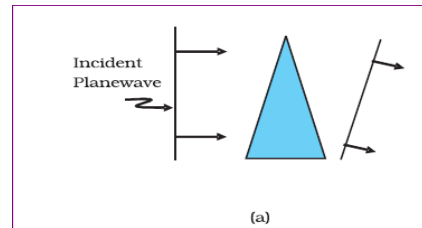

A plane wave incident on a thin convex lens

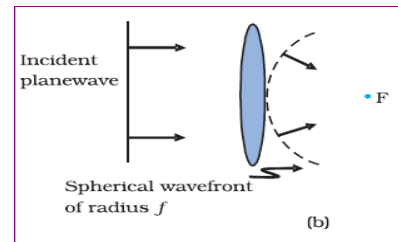

A plane wave is incident on a concave mirror

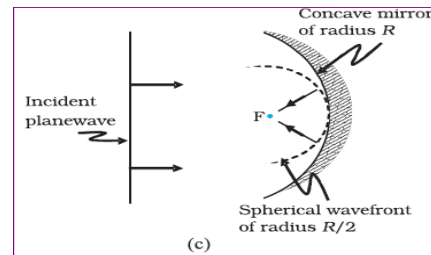

The Doppler effect

- The apparent change in frequency of light seen by an observer, whenever there is a relative motion between source and observer is called Doppler Effect.
- When **the source is moving towards the observer** with a velocity v , then the apparent frequency of light

$$\nu' = \nu \left(1 + \frac{v}{c}\right)$$

- Where ν - actual frequency, v – velocity
- Therefore the fractional change in frequency

$$\frac{\Delta \nu}{\nu} = \frac{v}{c}$$

- If the source is moving away from the observer, the apparent frequency

$$\nu' = \nu \left(1 - \frac{v}{c}\right)$$

- Hence the fractional change in frequency is

Refraction at a rarer medium

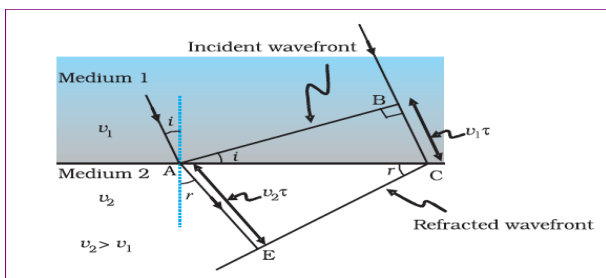

- The angle of refraction will be greater than angle of incidence.
- Thus, if $i = i_c$ then $\sin r = 1$ and $r = 90^\circ$.

$$\sin i_c = \frac{n_2}{n_1}$$

- Therefore
- The angle i_c is known as the **critical angle** and for all angles of incidence greater than the critical angle the wave will undergo **total internal reflection**.

Reflection of a plane wave by a plane surface

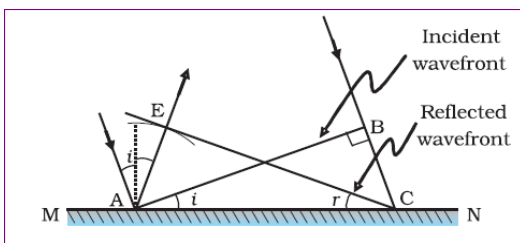

- If v represents the speed of the wave in the medium and if τ represents the time taken by the wavefront to advance from the point B to C then $BC = v\tau$
- Also $AE = BC = v\tau$
- The triangles EAC and BAC are congruent

$$\frac{\Delta \nu}{\nu} = -\frac{v}{c}$$

Red shift

- When the source moves away from the observer, there is an apparent decrease in the frequency of light. This is called **red shift**.

Blue shift

- When the source moves towards the observer, there is an apparent increase in the frequency of observed light. This is called **blue shift**.

POLARISATION

- When ordinary light passes through certain crystals like tourmaline crystal, the vibrations of electric field vector are restricted. This phenomenon is called **polarization**.
- Polarization shows that **light is a transverse wave**.
- Sound waves cannot polarize.

Unpolarised light

- The ordinary light which contains the vibrations of electric field vector in every plane perpendicular to the direction of propagation is called unpolarised light.

Representation of unpolarised light

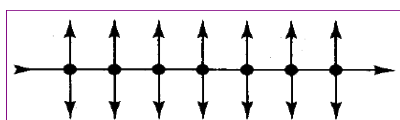

Plane polarized light

- The polarized light in which the electric field vibrations of light are confined to a single plane are called plane polarised light.

Representation of plane polarised light

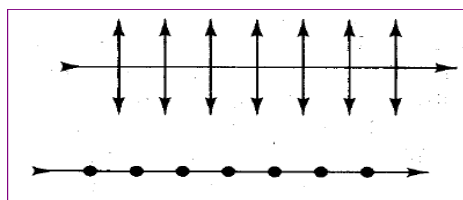

Plane of vibration

- It is the plane in which the vibrations of the polarized light take place.

Plane of polarization

- It is the plane perpendicular to the plane of vibration of the plane polarized light.

Polarizer

- The crystal which produces polarized light is called a polarizer.

Analyzer

- The crystal which is used to check whether the light is polarized or not is called analyzer or detector.

An experiment to study polarization of light

- When unpolarized light passes through polarizer the light coming out of it is plane polarized.

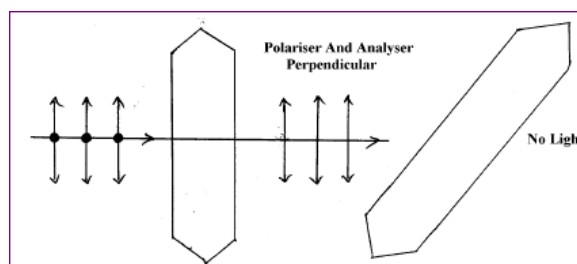
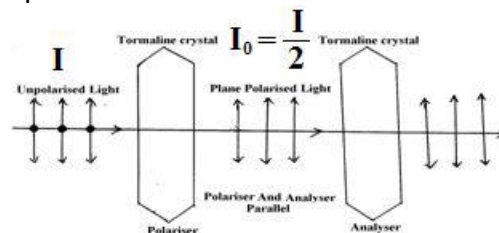

- If the polarizer and analyser are parallel the intensity of light coming through the analyser will be maximum.
- If the analyser is rotated through 90° the intensity of light coming out of it becomes zero.

Polaroids

- Polaroid is an artificially made polarising material that produce intense beam of polarised light by selective absorption.
- Polaroids are in sunglasses, windowpanes, photographic cameras, 3D movie cameras etc.

Malus' law

- Malus's law states that when a beam of plane polarised light is incident on the analyser, then the intensity of the emergent light is directly proportional to square of the cosine of the angle between the polariser and analyser.

$$I = I_0 \cos^2 \theta$$

- Where θ is the angle between the axes of polarizer and analyzer.

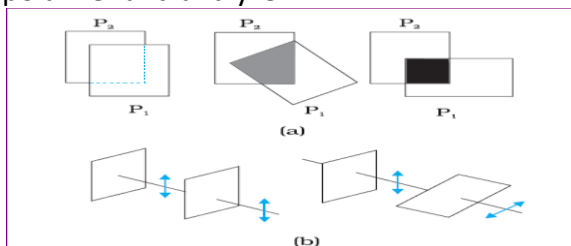

Methods of polarization

- Polarization by scattering
- Polarisation by reflection

Polarization by scattering

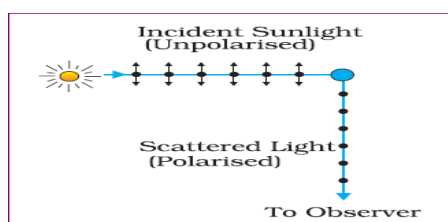

- When sunlight is incident on the gas molecules in the atmosphere, it gets scattered.
- The scattered light seen in a direction perpendicular to the direction of incidence is found to be plane polarised. This phenomenon is called polarisation by scattering.
- When this polarised light is viewed through a polaroid which is rotated, then the intensity changes with rotation.
- The scattering of light by molecules was intensively investigated by C.V. Raman and his collaborators. Raman was awarded the Nobel Prize for Physics in for this work.

Polarisation by reflection

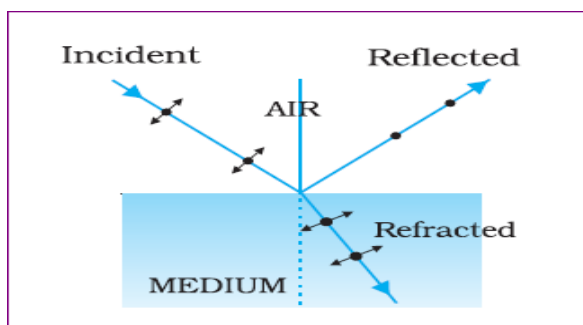

- When ordinary light falls on a surface separating two transparent media, a part

of the light is reflected and the other part is transmitted (refracted).

- When reflected wave is perpendicular to the refracted wave, the reflected wave is a totally polarised wave.

Brewster's angle (polarizing angle)

- The angle of incidence at which the reflected ray is totally polarized is called **Brewster's angle** and is denoted by i_B .

Brewster's law

- Brewster's law states that the tangent of the Brewster's angle is equal to the refractive index of the medium.

$$\tan i_B = \mu$$

Proof

- From Snell's law

$$\mu = \frac{\sin i_B}{\sin r} = \frac{\sin i_B}{\sin(\pi/2 - i_B)}$$

$$= \frac{\sin i_B}{\cos i_B} = \tan i_B$$

Distinguishing a polarized light and unpolarized light

- When we observe unpolarised light (ordinary light) through a Nicol prism (tourmaline crystal), the intensity of the light coming out of the prism does not change if the crystal is rotated.
- But when we observe polarized light through a Nicol prism, the intensity of the light coming out of the prism changes if the crystal is rotated.

Chapter Eleven

DUAL NATURE OF RADIATION AND MATTER

(Prepared by AYYAPPAN C, HSST, GMRHSS KASARAGOD)

PHOTOELECTRIC EFFECT

- The phenomenon of ejection of electrons when light of suitable frequency falls on it is called **photoelectric effect**.
- Photoelectric emission was discovered in by **Heinrich Hertz**.
- In photoelectric effect the light energy is converted to electrical energy.
- The photo (light)-generated electrons are called **photoelectrons** and the current is called **photo current**.
- Substances that respond to light are called **photo sensitive substances**.
- Metals like **zinc, cadmium, magnesium** etc respond only to **ultra violet light**.
- Alkali metals such as **lithium, sodium, potassium, cesium and rubidium** are sensitive to **visible light**.

Hallwachs' and Lenard's observations

- Wilhelm Hallwachs and Philipp Lenard studied photo electric effect in detail using an evacuated glass tube with two zinc plates as electrodes.

Experimental set up

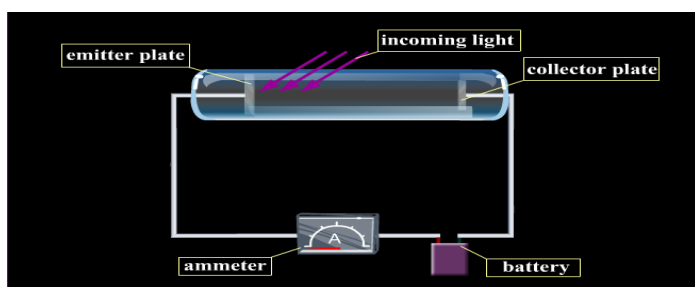

Observations

- When ultraviolet radiations were allowed to fall on the emitter plate current flows in the circuit.
- When collector plate is illuminated no current flows.
- When the frequency of incident radiation is less than a certain minimum value no photo electrons emission is possible. This

minimum frequency is called **threshold frequency**.

- Threshold frequency depends on the nature of the metal.

Laws of Photoelectric emission

- The photoelectric current is directly proportional to the intensity of incident light and independent of the frequency.
- Kinetic energy of emitted photo electrons depends on the frequency and does not depend on intensity of radiation.
- For each metal there is a threshold frequency, below which no photoelectron emission is possible.
- The photoelectric emission is an instantaneous process.

EINSTEIN'S EXPLANATION OF PHOTO ELECTRIC EFFECT

- Einstein explained photoelectric effect based on quantum theory.
- According to quantum theory, light contain photons having energy $h\nu$.
- When a photon of energy $h\nu$ is incident on a metal surface, electrons are emitted.
- A part of the photon energy is used as the work function and the remaining part of the photon energy appears as the kinetic energy of photoelectrons.

Einstein's photoelectric equation

- Photon Energy = Work function + maximum K.E. of photoelectron.
- That is

$$h\nu = \phi_0 + K_{\max}$$

- Thus

$$K_{\max} = h\nu - \phi_0$$

- But the work function is given by $\phi_0 = h\nu_0$, where ν_0 is the **threshold frequency**.
- Therefore

$$K_{\max} = h(\nu - \nu_0)$$

- This equation is the Einstein's photo electric equation.

Frequency - stopping potential graph (for different metals)

- We have, the photo electric equation,

$$K_{\max} = h\nu - \phi_0$$

- Also in terms of stopping potential

$$K_{\max} = e V_0$$

- Thus $eV_0 = h\nu - \phi_0$

- That is
$$V_0 = \frac{h}{e} \nu - \frac{\phi_0}{e}$$

- It predicts that the V_0 versus ν curve is a straight line with slope = (h/e) , independent of the nature of the material.

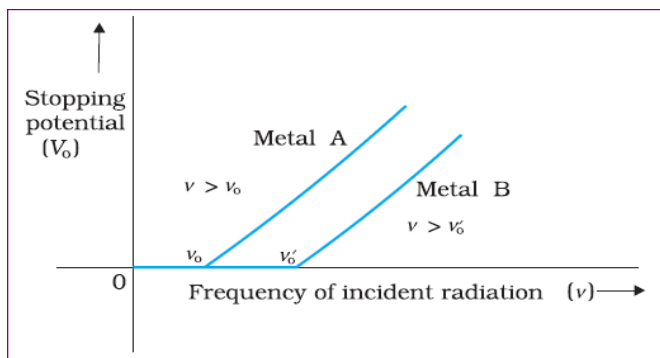

- Thus **Planck's constant = slope X charge of electron.**
- The y-intercept is $-\frac{\phi_0}{e}$, therefore the **work function = - (y intercept) X charge of electron.**

Photoelectric cell

- Photoelectric cell is a device used to convert light energy into electric energy using the principle of photoelectric effect.

PARTICLE NATURE OF LIGHT:

THE PHOTON

- In interaction of radiation with matter, radiation behaves as if it is made up of particles called photons.

Properties of Photons

- Each photon has energy $E (=h\nu)$ and momentum $p (= h \nu/c)$, and speed c , the speed of light.
- All photons of light of a particular frequency ν , or wavelength λ , have the same energy $E (=h\nu = hc/\lambda)$ and momentum $p (= h\nu/c = h/\lambda)$, independent of intensity of light.
- By increasing the intensity of light of given wavelength, there is only an **increase in** the number of photons per second crossing a given area, with each photon having the same energy.
- The photon energy is independent of intensity of radiation.
- Photons are electrically neutral and are not deflected by electric and magnetic fields.
- In a photon-particle collision (such as photon-electron collision), the total energy and total momentum are conserved.
- However, the number of photons may not be conserved in a collision. The photon may be absorbed or a new photon may be created.

Dual nature of radiation

- Radiation has wave nature as well as particle nature. This is called the dual nature of radiation.





Chapter Twelve ATOMS

(Prepared by AYYAPPAN C, HSST, GMRHSS KASARAGOD)

Limitations of Rutherford Model

- Rutherford's model fails to account for the stability of the atom.
- The energy of an accelerating electron should continuously decrease and the electron would spiral inward and eventually fall into the nucleus.

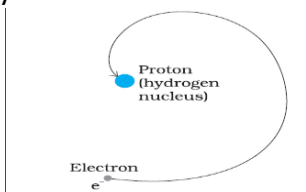

- Rutherford's model does not explain the line spectra of atoms.

BOHR MODEL OF THE HYDROGEN ATOM

- Bohr combined classical and early quantum concepts and gave his theory in the form of three postulates:

Postulate I

- **Electrons in an atom can revolve in certain stable orbits without radiating energy.**
- According to this postulate, each atom has certain definite stable states in which it can exist, and each possible state has definite total energy.
- These are called the **stationary states** of the atom

Postulate II

- **The electron revolves around the nucleus only in those orbits for which the angular momentum is some integral multiple of $h/2\pi$ where h is the Planck's constant ($= 6.6 \times 10^{-34} \text{ J s}$).**
- Thus the angular momentum (L) of the orbiting electron is quantised.
- That is $L = nh/2\pi$, where $n = 1, 2, 3, \dots$, is the principal quantum number.

Postulate III

- **An electron might make a transition from one of its specified non-radiating orbits to another of lower energy.**

- A photon is emitted having energy equal to the energy difference between the initial and final states.
- The frequency of the emitted photon is then given by

$$h\nu = E_i - E_f$$

Radii of Bohr's Stationary orbits:

- The centripetal force for the revolution of electrons round the nucleus is provided by the electrostatic force of attraction between the nucleus and the electron.
- Thus

$$\frac{mv^2}{r} = \frac{1}{4\pi\epsilon_0} \frac{e^2}{r^2}$$

- Therefore

$$mv^2 = \frac{1}{4\pi\epsilon_0} \frac{e^2}{r}$$

- From Bohr's II postulate the angular momentum $L = mvr$, is given by

$$mvr = \frac{nh}{2\pi}$$

- Thus

$$v = \frac{nh}{2\pi mr}$$

- Therefore

$$m \left(\frac{nh}{2\pi mr} \right)^2 = \frac{1}{4\pi\epsilon_0} \frac{e^2}{r} \quad \left| \quad m \frac{n^2 h^2}{4\pi^2 m^2 r^2} = \frac{1}{4\pi\epsilon_0} \frac{e^2}{r} \right.$$

- That is

$$\frac{n^2 h^2}{\pi m r} = \frac{e^2}{\epsilon_0}$$

- The radius is given by

$$r = \frac{\epsilon_0 n^2 h^2}{\pi m e^2}$$

- In general

$$r_n = \left(\frac{\epsilon_0 h^2}{\pi m e^2} \right) n^2$$

- Thus

$$r_n \propto n^2$$

- The radii of the stationary orbits are in the ratio, $1^2:2^2:3^2:\dots$ or $1:4:9:\dots$

- The stationary orbits are not equally spaced.

Bohr Radius

- The radius of the lowest orbit ($n=1$) is called Bohr radius.
- The Bohr radius is given by

$$a_0 = \frac{h^2 \epsilon_0}{\pi m e^2}$$

- Substituting the values we get

$$a_0 = 5.29 \times 10^{-11} \text{ m}$$

- Thus the radius of n^{th} orbit becomes:

$$r_n = a_0 n^2$$

Velocity of electrons in an orbit

- We have

$$v = \frac{nh}{2\pi m r}$$

- But

$$r = \frac{\epsilon_0 n^2 h^2}{\pi m e^2}$$

- Therefore

$$v = \frac{nh}{2\pi m \left(\frac{\epsilon_0 h^2}{\pi m e^2} \right) n^2}$$

- That is

$$v = \frac{e^2}{2\epsilon_0 n h}$$

- In general

$$v_n = \frac{e^2}{2\epsilon_0 n h}$$



$$K = \frac{1}{2} m v^2 = \frac{e^2}{8\pi\epsilon_0 r}$$

Potential energy

- The electrostatic potential energy of an orbital electron is given by

$$U = -\frac{e^2}{4\pi\epsilon_0 r}$$

Total energy

- Total energy is given by

$$E = K + U = \frac{e^2}{8\pi\epsilon_0 r} - \frac{e^2}{4\pi\epsilon_0 r}$$

- That is

$$E = \frac{-e^2}{8\pi\epsilon_0 r}$$

- But, we have

$$r = \frac{\epsilon_0 n^2 h^2}{\pi m e^2}$$

- Thus

$$E = \frac{-e^2}{8\pi\epsilon_0 \times \frac{\epsilon_0 h^2 n^2}{\pi m e^2}}$$

- In general

$$E_n = \frac{-m e^4}{8\epsilon_0^2 h^2 n^2}$$

- Substituting the values we get

$$E_n = -\frac{13.6}{n^2} \text{ eV}$$

Energy level diagram of hydrogen atom

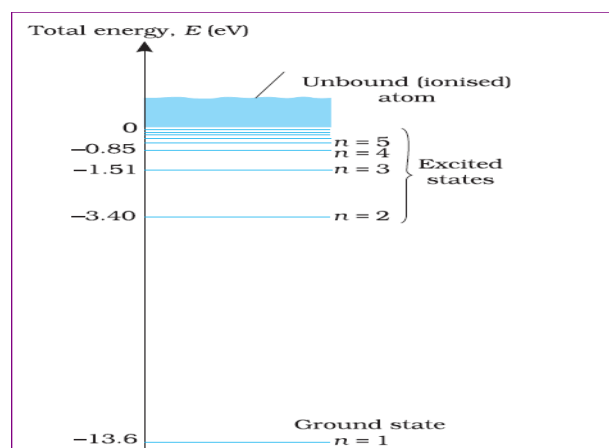

Total energy of an orbiting electron

Kinetic energy

- For an orbiting electron, we have

$$\frac{m v^2}{r} = \frac{1}{4\pi\epsilon_0} \frac{e^2}{r^2}$$

- Or

$$m v^2 = \frac{1}{4\pi\epsilon_0} \frac{e^2}{r}$$

- Thus the kinetic energy is given by

Excitation energy

- Excitation energy is the **energy required to excite an electron from its ground state to an excited state.**
- First excitation energy of hydrogen atom required to excite the electron from $n = 1$ to $n = 2$ orbit of hydrogen atom. That is $(-3.4) - (-13.6) = 10.2 \text{ eV}$.

Excitation potential

- Excitation potential of an excited state is the potential difference through which electron in an atom has to be accelerated so as to excite it from its ground state to the given excited state.
- The **first excitation potential of H atom** is 10.2V.

Ionization energy

- Ionisation energy is the energy required to take an electron completely out of the atom.
- The ionization energy of hydrogen atom is 13.6 eV.

DE BROGLIE'S EXPLANATION OF BOHR'S SECOND POSTULATE OF QUANTISATION

- Louis de Broglie argued that the electron in its circular orbit, as proposed by Bohr, must be seen as a particle wave.
- In analogy to waves travelling on a string, particle waves too can lead to standing waves under resonant conditions.
- In a string, standing waves are formed when the total distance travelled by a wave down the string and back is one wavelength, two wavelengths, or any integral number of wavelengths.

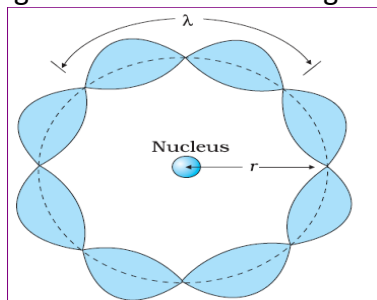

- For an electron moving in n th circular orbit of radius r_n , the total distance is the circumference of the orbit, $2\pi r_n$.

$$2\pi r_n = n\lambda, \quad n = 1, 2, 3\dots$$

- But we have $\lambda = h/p$,

$$2\pi r_n = n h / m v_n \quad \text{or} \quad m v_n r_n = n h / 2\pi$$

- This is the quantum condition proposed by Bohr for the angular momentum of the electron

Limitations of Bohr Model

- Bohr's theory is applicable only to single electron atoms.
- This theory gives no idea about relative intensities of spectral lines.
- Could not explain the fine structure of hydrogen spectrum.



Chapter Thirteen

NUCLEI

(Prepared by AYYAPPAN C, HSST, GMRHSS KASARAGOD)

RADIOACTIVITY

- **H. Becquerel** discovered radioactivity in 1896.
- Radioactivity is a nuclear phenomenon in which an unstable nucleus undergoes a decay. This is referred to as **radioactive decay**.
- **Three types of radioactive decay occur in nature** :
- **α -decay** in which a helium nucleus (He) is emitted;
- **β -decay** in which electrons or positrons (particles with the same mass as electrons, but with a charge exactly opposite to that of electron) are emitted;
- **γ -decay** in which high energy (hundreds of keV or more) photons are emitted.

Law of radioactive decay

- **This law states that the number of nuclei undergoing the decay per unit time is proportional to the total number of nuclei in the sample.**
- If a sample contains N undecayed nuclei and let dN nuclei disintegrate in dt second, thus the rate of disintegration

$$\frac{dN}{dt} \propto -N$$

- The negative sign shows that the number of nuclei decreases with time.
- Thus

$$\frac{dN}{dt} = -\lambda N$$

- Where λ is called the **radioactive decay constant or disintegration constant**.

$$\text{or, } \frac{dN}{N} = -\lambda dt$$

- Now, integrating both sides of the above equation, we get

$$\int_{N_0}^N \frac{dN}{N} = -\lambda \int_{t_0}^t dt$$

$$\text{or, } \ln N - \ln N_0 = -\lambda (t - t_0)$$

- Here N_0 is the number of radioactive nuclei in the sample at some arbitrary time t_0 and N is the number of radioactive nuclei at any subsequent time t .
- Setting $t_0 = 0$

$$\ln \frac{N}{N_0} = -\lambda t$$

- Thus

$$N = N_0 e^{-\lambda t}$$

Decay Rate

- It gives the number of nuclei decaying per unit time

$$R = -\frac{dN}{dt}$$

$$R = -\frac{dN}{dt} = \lambda N_0 e^{-\lambda t}$$

$$\text{or, } R = R_0 e^{-\lambda t}$$

- Here R_0 is the radioactive decay rate at time $t = 0$, and R is the rate at any subsequent time t .
 - Thus
- $$R = \lambda N$$
- The **total decay rate R** of a sample of one or more radionuclide's is called the **activity** of that sample.
 - The **SI unit for activity is becquerel**, named after the discoverer of radioactivity.
 - **1 becquerel = 1 Bq = 1 decay per second**
 - An older unit, the **curie**, is still in common use.

$$1 \text{ curie} = 1 \text{ Ci} = 3.7 \times 10^{10} \text{ Bq (decays per second)}$$

Half life period ($T_{1/2}$)

- **It is the time in which the number of undecayed nuclei falls into half of its original number.**
- Thus it is the time at which both N and R have been reduced to one-half their initial values.

$$T_{1/2} = \frac{\ln 2}{\lambda} = \frac{0.693}{\lambda}$$



We have $N = N_0 e^{-\lambda t}$

When $t = T_{1/2}$, $N = \frac{N_0}{2}$

$$\frac{N_0}{2} = N_0 e^{-\lambda T_{1/2}}$$

i.e. $e^{-\lambda T_{1/2}} = \frac{1}{2}$

or $\lambda T_{1/2} = \ln 2$

$$T_{1/2} = \frac{0.693}{\lambda}$$

Mean life (τ)

- It is the average life of all the nuclei in a radioactive sample.
- Mean life = total life time of all nuclei / total number of nuclei present initially

$$\tau = \frac{1}{\lambda}$$

- The number of nuclei which decay in the time interval t to $t + \Delta t$ is

$$R(t)\Delta t = (\lambda N_0 e^{-\lambda t} \Delta t)$$

- Each of them has lived for time t . Thus the total life of all these nuclei would be

$$t \lambda N_0 e^{-\lambda t} \Delta t$$

- Therefore mean life is given by

$$\tau = \frac{\lambda N_0 \int_0^{\infty} t e^{-\lambda t} dt}{N_0} = \lambda \int_0^{\infty} t e^{-\lambda t} dt$$

One can show by performing this integral that $\tau = 1/\lambda$

We summarise these results with the following:

$$T_{1/2} = \frac{\ln 2}{\lambda} = \tau \ln 2 \quad (1)$$

Alpha decay

- When a nucleus undergoes *alpha-decay*, it transforms to a different nucleus by emitting an alpha-particle (a helium nucleus)

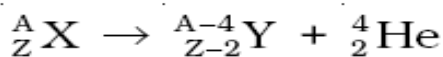
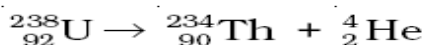

- The difference between the initial mass energy and the final mass energy of the decay products is called the ***Q value of the process or the disintegration energy.***

$$Q = (m_X - m_Y - m_{\text{He}}) c^2$$

- This energy is shared by the daughter nucleus and the alpha particle, in the form of kinetic energy
- Alpha-decay obeys the radioactive law
- Alpha particles are positively charged particles
- Can be deflected by electric and magnetic fields.
- Can affect photographic plates.

Beta decay

- A nucleus that decays spontaneously by emitting an electron or a positron is said to undergo beta decay.**
- In beta-minus decay**, a neutron transforms into a proton within the nucleus according to

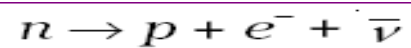

- Where $\bar{\nu}$ is the antineutrino
- In beta minus (β^-) decay, an electron is emitted by the nucleus.

- Eg:**

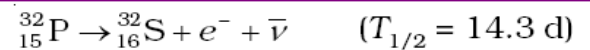

- When β^- particles are emitted, **the atomic number increases by one.**
- In beta-plus decay**, a proton transforms into neutron (inside the nucleus)

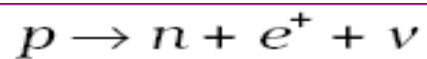

- Where ν is the neutrino
- In beta plus (β^+) decay, a positron is emitted by the nucleus,

- Eg:**

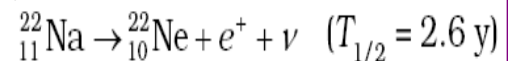

- When β^+ particles are emitted the **atomic number decreases by one.**

Neutrinos and Antineutrinos

- The particles which are emitted from the nucleus along with the electron or positron during the decay process.

- Neutrinos interact only very weakly with matter; they can even penetrate the earth without being absorbed.

Gamma decay

- There are energy levels in a nucleus, just like there are energy levels in atoms.
- When a nucleus is in an excited state, it can make a transition to a lower energy state by the emission of electromagnetic radiation.
- As the energy differences between levels in a nucleus are of the order of MeV, the photons emitted by the nuclei have MeV energies and are called gamma rays.

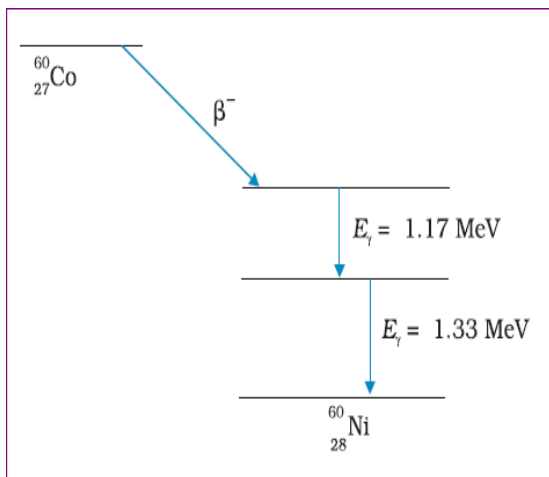

- Most radionuclides after an alpha decay or a beta decay leave the daughter nucleus in an excited state.
- The daughter nucleus reaches the ground state by a single transition or sometimes by successive transitions by emitting one or more gamma rays.

Properties of Radioactive radiations

Property	α	β	γ
Equivalent to	${}^4_2\text{He}$	${}^0_{-1}\text{e}$ or ${}^0_{+1}\text{e}$	Electromagnetic wave
Charge	Positive	Negative	No charge
Behaviour in E and B field	Deflected	Deflected	Not Deflected
Rest mass	Equal to helium	Equal to electron	Zero rest mass
Speed	$\frac{1}{10}$ velocity of light	0.99C	C
Penetrating power	low	high	Very high
Ionisation power	Very high	high	low

NUCLEAR ENERGY

- In conventional energy sources like coal or petroleum, energy is released through chemical reactions.
- One kilogram of coal on burning gives 10^7 J of energy, whereas 1 kg of uranium, which undergoes fission, will generate on fission 10^{14} J of energy.

Nuclear Fission

- Enrico Fermi found that when neutrons bombard various elements, new radioactive elements are produced.
- Eg:

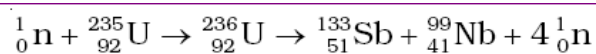
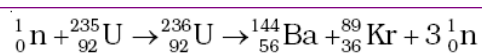

Still another example is

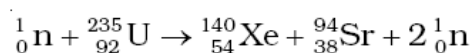

- The fragment nuclei produced in fission are highly neutron-rich and unstable.
- They are radioactive and emit beta particles in succession until each reaches a stable end product.
- The **energy released (the Q value) in the fission reaction of nuclei like uranium** is of the order of **200 MeV** per fissioning nucleus.
- The disintegration energy in fission events first appears as the kinetic energy of the fragments and neutrons.
- Eventually it is transferred to the surrounding matter appearing as heat.
- The source of energy in **nuclear reactors, which produce electricity, is nuclear fission.**
- The enormous energy released in an **atom bomb comes from uncontrolled nuclear fission.**

Nuclear reactor

- Neutrons liberated in fission of a uranium nucleus were so energetic that they would escape instead of triggering another fission reaction.

- Slow neutrons have a much higher intrinsic probability of inducing fission in U (235) than fast neutrons.
- The **average energy of a neutron produced in fission of U (235) is 2 MeV.**
- In reactors, light nuclei called **moderators** are provided along with the fissionable nuclei for **slowing down fast neutrons.**
- The moderators commonly used are **water, heavy water (D2O) and graphite.**
- The Apsara reactor at the Bhabha Atomic Research Centre (BARC), Mumbai, uses water as moderator.
- The other Indian reactors, which are used for power production, use heavy water as moderator.

Multiplication factor

- It is the ratio of number of fission produced by a given generation of neutrons to the number of fission of the preceding generation.
- It is the measure of the growth rate of the neutrons in the reactor.
- For $K = 1$, the operation of the reactor is said to be *critical*, which is what we wish it to be for steady power operation.
- If K becomes greater than one, the reaction rate and the reactor power increases exponentially.
- Unless the factor K is brought down very close to unity, the reactor will become supercritical and can even explode.
- The explosion of the Chernobyl reactor in Ukraine in 1986 is a sad reminder that accidents in a nuclear reactor can be catastrophic.
- The reaction rate is controlled through **control-rods** made out of neutron-absorbing material such as **cadmium.**
- In addition to control rods, reactors are provided with **safety rods** which, when required, can be inserted into the reactor and K can be reduced rapidly to less than unity.

- The abundant U(238) isotope, which does not fission, on capturing a neutron leads to the formation of plutonium.

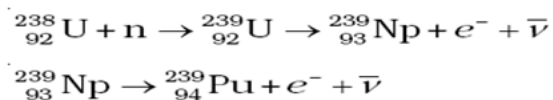

- Plutonium is highly radioactive and can also undergo fission under bombardment by slow neutrons

Pressurized-water reactor

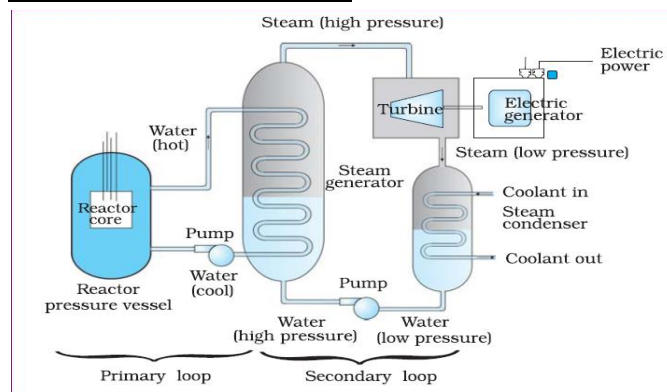

- In such a reactor, water is used both as the moderator and as the heat transfer medium
- In the *primary-loop*, water is circulated through the reactor vessel and transfers energy at high temperature and pressure (at about 600 K and 150 atm) to the steam generator, which is part of the *secondary-loop*.
- In the steam generator, evaporation provides high-pressure steam to operate the turbine that drives the electric generator.
- The low-pressure steam from the turbine is cooled and condensed to water and forced back into the steam generator.
- A kilogram of U(235) on complete fission generates about 3×10^4 MW.
- In nuclear reactions highly radioactive elements are continuously produced.
- Therefore, an unavoidable feature of reactor operation is the accumulation of radioactive waste, including both fission products and heavy *transuranic elements* such as plutonium and americium.

Nuclear fusion



- Energy can be released if two light nuclei combine to form a single larger nucleus, a process called *nuclear fusion*.

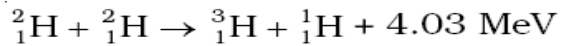
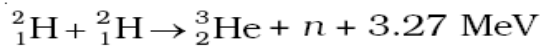
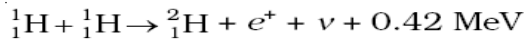

- The fusion reaction in the sun is a multi-step process in which hydrogen is burned into helium, hydrogen being the 'fuel' and helium the 'ashes'.
- The **proton-proton (p, p) cycle by which this occurs is represented** by the following sets of reactions:.

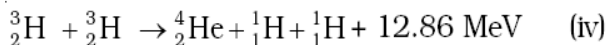
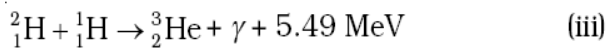
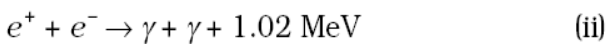
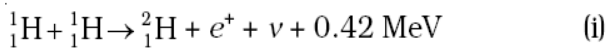

- The combined reaction is

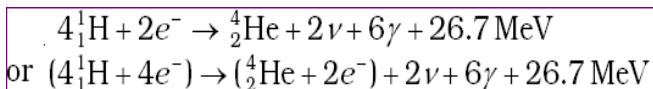

- In sun it has been going on for about 5×10^9 y, and calculations show that there is enough hydrogen to keep the sun going for about the same time into the future.
- In about 5 billion years, however, the sun's core, which by that time will be largely helium, will begin to cool and the sun will start to collapse under its own gravity.
- This will raise the core temperature and cause the outer envelope to expand, turning the sun into what is called a **red giant**.
- If the core temperature increases to 10^8 K again, energy can be produced through fusion once more – this time by burning helium to make carbon.

Controlled thermonuclear fusion

- The first thermonuclear reaction on earth occurred at Eniwetok Atoll on November 1, 1952, when USA exploded a fusion

device, generating energy equivalent to 10 million tons of TNT (one ton of TNT on explosion releases 2.6×10^{22} MeV of energy).

- A sustained and controllable source of fusion power is considerably more difficult to achieve.



Chapter 14

SEMICONDUCTOR ELECTRONICS

(Prepared By: Ayyappan C, HSS7 Physics, JMRHSS, Kasaragod)

p-n JUNCTION

- A junction formed when a p-type semiconductor and n-type conductor are brought together is called a p-n junction.

SEMICONDUCTOR DIODE (p-n junction Diode)

- A semiconductor diode is a p-n junction with metallic contacts provided at the ends for the application of an external voltage.
- It is a two terminal device.

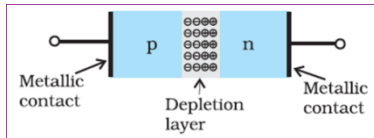

Symbol



- The barrier voltage of a **Ge** diode is **0.2V** and that of a **Si** diode is **0.7V**.

p-n junction diode under forward bias

- In forward biasing the **p-side is connected to the positive terminal** of the battery and **n-side to the negative terminal**.
- In forward bias, the junction offers a very low resistance to the flow of current

p-n junction diode under reverse bias

- In reverse biasing **n-side is connected to positive** of the battery and **p-side to negative** of the battery.
- In reverse biasing Junction resistance is very high for current flow

APPLICATION OF JUNCTION DIODE - RECTIFIER

- The process of conversion of ac current to dc current is called **rectification**.
- Device used for rectification is called rectifier.

Half wave Rectifier:

- It uses only one diode.
- The diode becomes forward biased only in the positive half cycle of ac.
- Efficiency is only 40.6%.

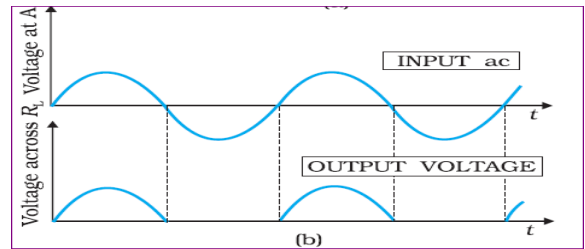
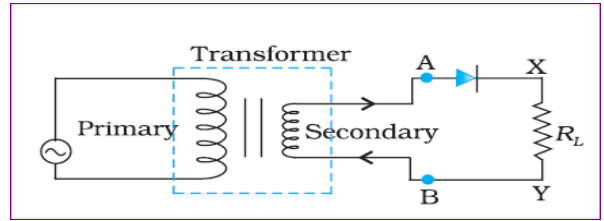

Full wave rectifier

- A simple full wave rectifier consists of two diodes.
- A centre tapped transformer is used in the circuit.
- During the positive half cycle first diode conducts current and second diode during negative half cycle.

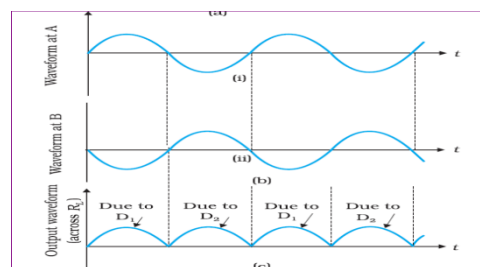
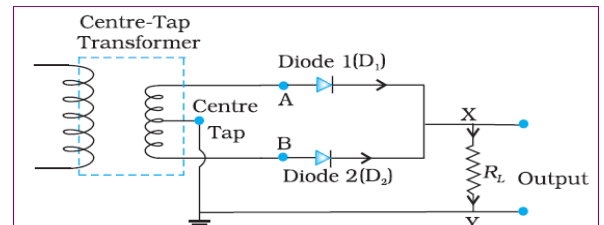

Filters

- The circuits used to filter out the ac ripples from the rectifier output are called **filters**.
- The capacitor input filters use large capacitors.

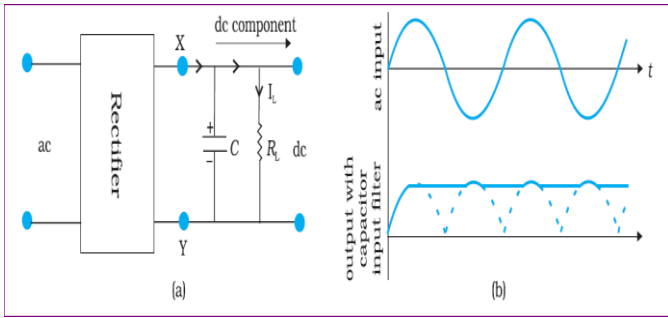

DIGITAL ELECTRONICS

- In digital circuits only two values (represented by 0 or 1) of the input and output voltage are permissible.
- The continuous, time-varying voltage or current signals are called **continuous or analogue signals**.

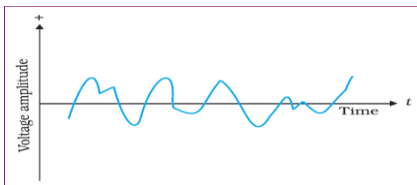

- A waveform in which only discrete values of voltages are possible is a **digital signal**.

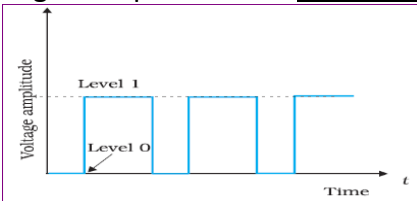

Logic gates

- A logic gate is a digital circuit that follows certain *logical relationship* between the input and output voltages.
- The five common logic gates used are **NOT, AND, OR, NAND, NOR**.
- NOT, OR, and AND gates are **fundamental or basic gates**.
- NAND and NOR gates are called **universal gates**.

NOT gate

- This is the most basic gate, with one input and one output.
- It produces an inverted version of the input at its output.
- It is also known as an **inverter**.
- The table which describes the input output relationship is known as **truth table**.

Truth table

Input	Output
A	Y
0	1
1	0

Symbol

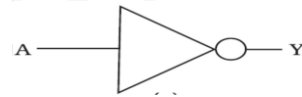

OR Gate

- It can have one output and any number of inputs.

Truth table

Input		Output
A	B	Y
0	0	0
0	1	1
1	0	1
1	1	1

Symbol

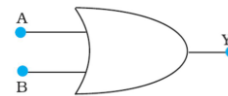

AND Gate

- It can have one output and any number of inputs.

Truth table

Input		Output
A	B	Y
0	0	0
0	1	0
1	0	0
1	1	1

Symbol

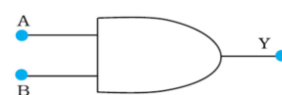

NAND Gate

- It is a combination of AND and NOT Gate

Truth table

Input		Output
A	B	Y
0	0	1
0	1	1
1	0	1
1	1	0



Symbol

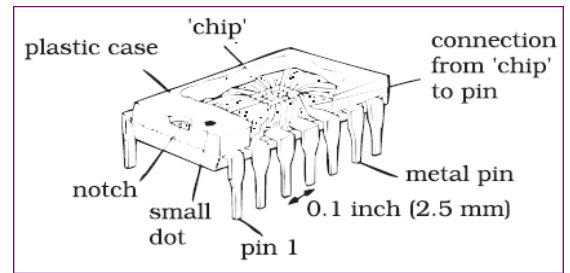
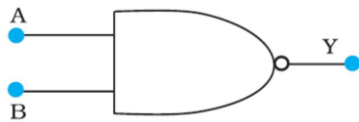

NOR Gate

- It is a combination of OR gate and NOT gate.

Truth table

Input		Output
A	B	Y
0	0	1
0	1	0
1	0	0
1	1	0

Symbol



INTEGRATED CIRCUITS (IC)

- An entire circuit fabricated (consisting of many passive components like R and C and active devices like diode and transistor) on a small single block (or chip) of a semiconductor is called **integrated circuit**.
- Depending on nature of input signals, IC's can be grouped in two categories: **linear or analogue IC's** and **digital IC's**
- Depending upon the level of integration (i.e., the number of circuit components or logic gates), the IC's are termed as
- **Small Scale Integration, SSI (logic gates < 10)**
- **Medium Scale Integration, MSI (logic gates < 100)**
- **Large Scale Integration, LSI (logic gates < 1000)**
- **Very Large Scale Integration, VLSI (logic gates > 1000).**
- The most widely used IC technology is the *Monolithic Integrated Circuit*.

