

# GEOMETRICAL AND MECHANICAL DRAWING

(Maximum Marks: 100)

(Time allowed: Three hours)

(Candidates are allowed additional 15 minutes for **only** reading the paper.  
They must **NOT** start writing during this time.)

---

The intended marks for questions or parts of questions are given in brackets [ ].

A sheet of drawing paper size A2 (594 mm × 420 mm) is provided.

All dimensions are in millimetres.

Arcs of circles less than 4 mm radius may be drawn freehand.

All construction lines must be shown clearly.

Accuracy and good draughtsmanship are essential.

Letter your Name, Index Number and Unique Identification Number (UID) at the bottom right-hand corner of your paper in a title block 120 mm × 50 mm.

---

Answer **all** Questions

## Question 1

Draw the three views of the given object (**Figure 1**) in correct projection.

**First or Third Angle:**

- (a) Front elevation in the direction of the arrow. [10]
- (b) The end elevation (side view). [10]
- (c) The plan (top view). [10]
- (d) Symbol of the method of projection you have chosen. [5]

## Question 2

**Figure 2** attached, shows the details of components of a V-Block assembly used for holding any workpiece like round metal rods or pipes. Assemble the parts as follows:

The lowermost part of the clamp (part 1, qty. 1) having 26 mm height is placed in the side cavities having 26 mm height of the V-Block (part 2, qty. 1). The handle (part 3, qty. 1) passes through the threaded central cavity of the clamp (part 1). The handle should be rested on the V-groove (90°) of the V-Block to save space by rotating downward.

- (a) Draw a full sectional view of the assembled components (along A – B). [30]
- (b) Draw the plan (top view) of the complete assembly omitting all the hidden details. [10]
- (c) Draw the side view of the assembly, omitting all the hidden details. [15]
- (d) Make a neat parts list for all the components, on the drawing sheet. [10]

---

This Paper consists of 3 printed pages and 1 blank page.

Figure 1 for Question 1

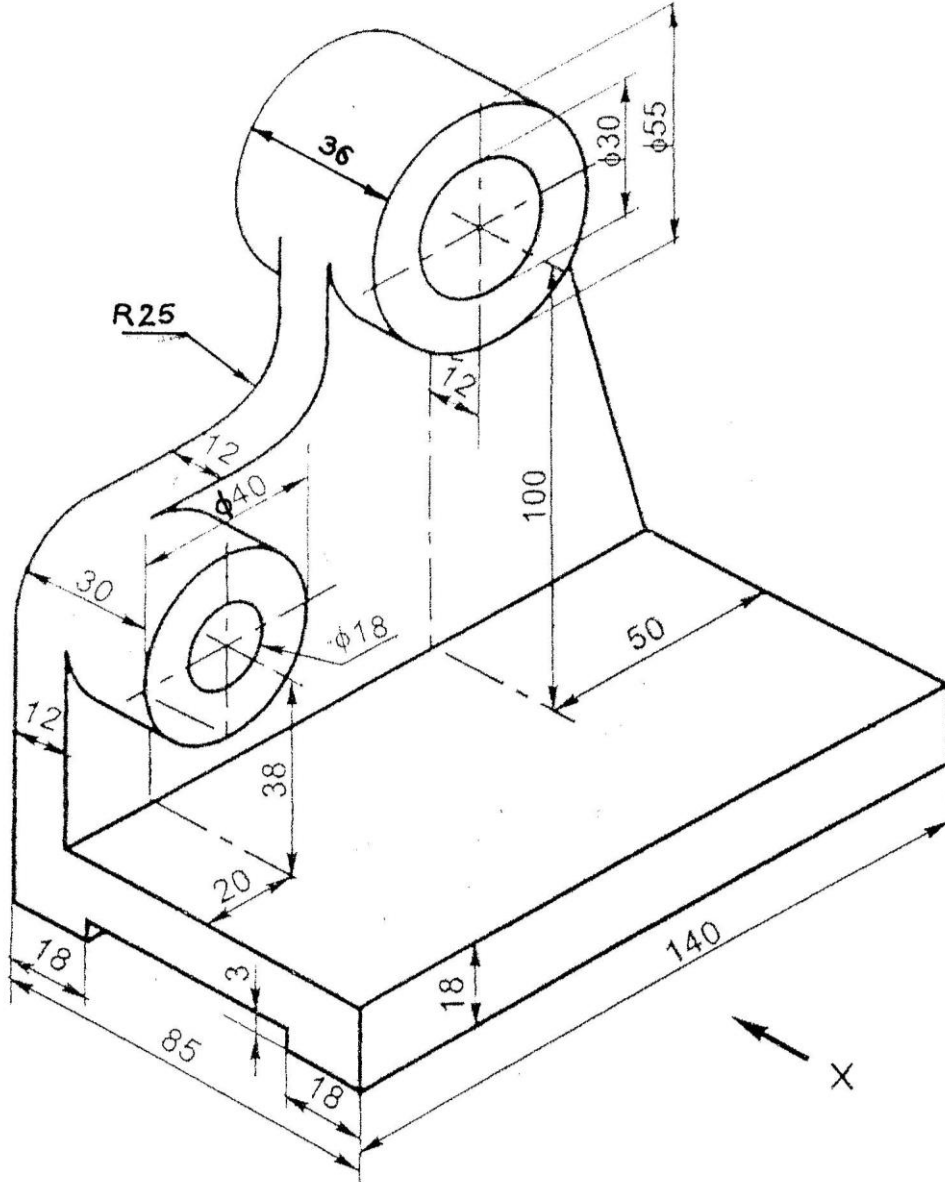

Figure 2 for Question 2

