

MODEL EVALUATION TEST 2021

PHYSICS

Standard X

Time: 1 ½ hrs

Maximum Score: 40

General Instructions:

- The first 20 minutes is the cool-off time. You may use this time to read and plan your answers.
- There are a total of 80 score questions. Out of these, the best written questions / sub-questions of 40 score will be considered for your score.
- It is not compulsory to answer all questions. But the maximum number of known answers can be written within the time allowed.
- Write the answers that you can write with confidence first.
- Write the question number/sub-question number clearly.

Section A

(Question 1 to 8 carries 1 score each)

1. Find the relation in the first pair and complete the second pair
Electric Heater : Heating effect
Electric Bulb: _____
2. Which part of the electric motor helps to change the direction of flow of current in the armature after every half rotation.
3. In India electricity is produced at _____ KV in power stations.
4. Which of the following device is used for the production of electricity ?
a) Motor b) Ammeter c) Galvanometer d) Generator
5. Write down the mirror formula.
6. Which phenomenon of light is used in Endoscope in medical field ?
7. Newton's colour disc is rotated fast it appears to be white. Why ?
8. D24 is marked on a cooking gas cylinder. What does it mean ?

Section B

(Question 9 to 20 carries 2 score each)

9. Tungsten is used as filament in electric bulb. Nichrome is not used as filament. Why ?
10. Observe the figure. When electricity flow through the conductor AB the magnetic needle deflects.

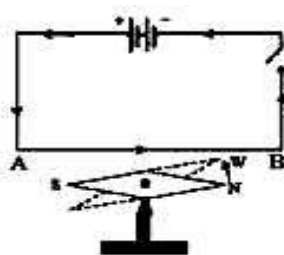

- a) Why does the magnetic needle deflect ?
- b) Which law helps to find out the direction of deflection ?

11. Complete the following using the terms given in brackets.
(Focal length, centre of curvature, principal axis, optic centre)

- a) The midpoint of a lens is _____
- b) The distance between optic centre and focus is _____
- c) The centre of the sphere of which the sides of the lens are parts is _____
- d) The line passing through the optic centre joining the two centres of curvature is called _____

12. Observe the figure.

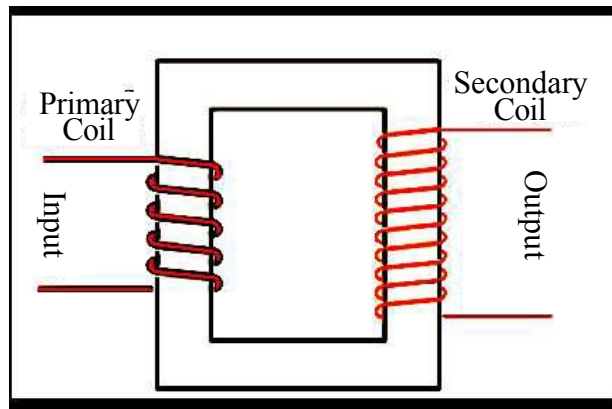

- a) Identify the device.
- b) Write the working principle of this device.

13. Observe the figure of reflection of light and answer following questions.

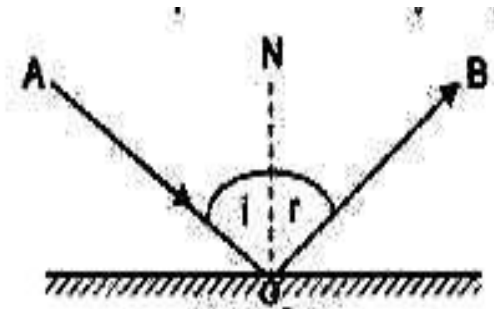

- a) Which is the incident ray ?
- b) Which is the reflected ray ?
- c) If the angle of incidence is 40° , what will be the angle of reflection ?

14. Match the following.

A	B
a) Magnification always one	Real image
b) Magnification always less than one	Virtual image
c) Magnification positive	Plane mirror
d) Magnification negative	Convex mirror

15. In a three phase connection,

- a) What is the potential of neutral line ?
- b) What is the potential difference between any two phase line ?

16. When sun light is allowed to fall on a prism the following colours are obtained at the screen.

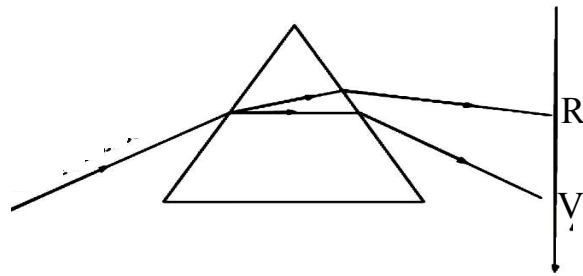

- a) Name the phenomenon of splitting up of light through a prism.
- b) Violet colour deviates more . Why ?

17. What are the precautions to be taken to avoid accidents due to LPG leakage ?
(mention any 2)

18. Observe the figure.

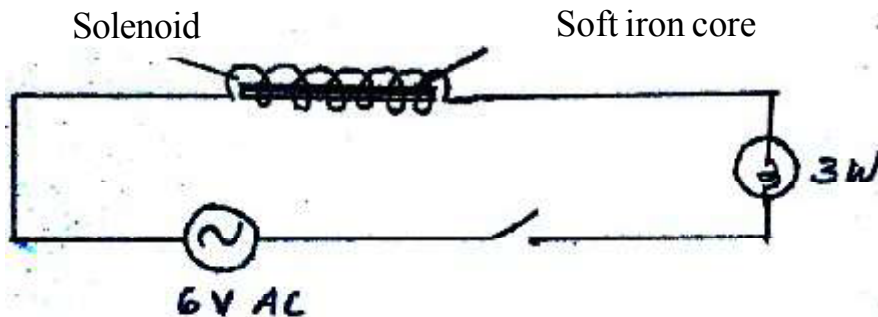

If the soft iron core is removed from the solenoid, what change will occur in the intensity of bulb ? Substantiate your answer.

19. Long-sightedness (Hypermetropia) is a defect of the eye in certain people.
- What is the problem in their vision ?
 - Which type of lens is used for rectifying this defect ?
20. What are advantages of LED bulb ? (any 2 advantages)

Section C

(Question 21 to 29 carries 3 score each)

21. Safety fuse is a device that works on the heating effect of electric current.
- Which material is used as fuse wire ?
 - What is the peculiarity of that material ?
 - Write one circumstance that leading to the melting of fuse wire ?
22. A current of 1 A flow through an electrical device of resistance 100 ohm.
- Calculate its power.
 - If this device works for 5 minutes, calculate the heat generated.
23. Figure of a generator is given below

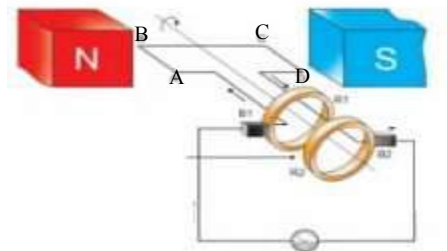

- Identify the type of generator.
 - If the induced current flows from C to D ,in which direction should be the portion CD move ? (Upwards/ Downwards)
 - Draw the graphical representation of emf produced from this generator.
24. A copper wire and Nichrome wire of same length and diameter connected in series in a circuit. When the current flow through the circuit,
- Which one will be heated more ? Why?
 - Which law will help to calculate the heat generated in the conductor ?
25. An object is placed in front of a concave mirror 40 cm away from it. If its focal length is 80 cm, locate the position of the image and its nature ?

26. Red light is used in tail lamps of vehicles and signal light.
- Which colour has highest wavelength in the visible spectrum ?
 - What is the relation between wavelength and scattering ?
 - Why red colour has been given to the signal lights ?

27. Observe the following figure of the device

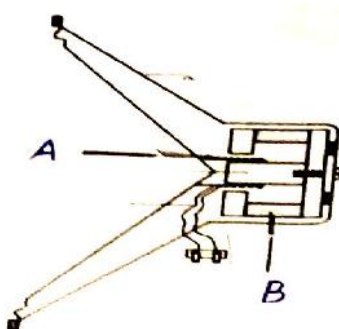

- Identify the given device .
 - Identify the parts A and B.
 - What is the energy transformation that takes place in this device ?
28. Complete the following diagram and write down the characteristics of the image formed.

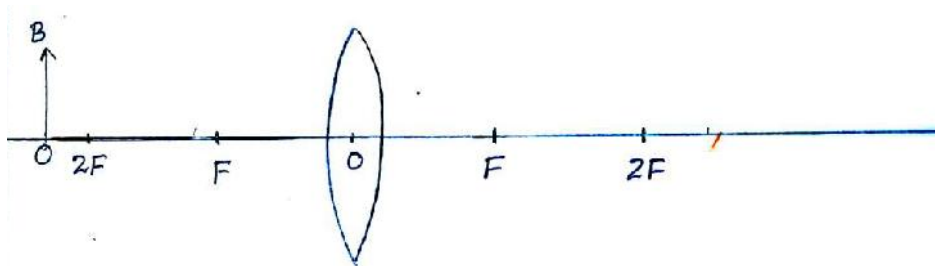

Section D

(Question 29 to 34 carries 4 score each)

29. Solenoid is an insulated wire wound in the shape of a helix.
- Which effect of electricity is used in the solenoid ?
 - What is the polarity at the end of the solenoid at which current flows in the clockwise direction?
 - Write any two factors affecting the strength of the magnetic field of a solenoid carrying current.

30. The nature of images formed by two lenses are given.
- (i) An erect and magnified virtual image.
 - (ii) An erect and diminished virtual image.
- a) What type of lens is used in each case ?
- b) By using which type of lens will be get an image having the same size as that of the object ?
- What is the position of the object ?
31. In a transformer secondary current is 1 A and primary current is 0.5 A.
- a) Which type of transformer is this ?
 - b) If the secondary voltage is 200 V, what will be the primary voltage ?
 - c) What is the working principle of the transformer ?
- 32.
- a) How fossil fuels are formed on the earth crust?
 - b) Write any two examples for fossil fuels.
 - c) The energy from these sources are known as brown energy. Why ?
33. Two resistors of 3 ohm and 6 ohm, 6 V battery, connecting wire and switch are given.
- a) Draw the diagram of resistors connected in series.
 - b) If they are connected in parallel what will be the effective resistance.
- 34.
- a) What is the commercial unit of electrical energy ?
 - b) How are the household devices connected ?
 - c) In a house 5 CF Lamps each of 20W works for 4 hours, 4 fans each of 60 W work for 5 hours in a day. What will be the daily electrical energy consumption ?

MODEL EVALUATION TEST 2021

PHYSICS

Standard X

Time: 1 ½ hrs

Maximum Score: 40

General Instructions:

- The first 20 minutes is the cool-off time. You may use this time to read and plan your answers.
 - There are a total of 80 score questions. Out of these, the best written questions / sub-questions of 40 score will be considered for your score.
 - It is not compulsory to answer all questions. But the maximum number of known answers can be written within the time allowed.
 - Write the answers that you can write with confidence first.
 - Write the question number/sub-question number clearly.
-

SECTION A

I Questions 1-8 carries 1 score each.

1. Among these which instrument converts electrical energy to heat energy
(Electric bulb, Electric Fan, Electric iron ,Electric Motor)
2. If south pole is formed at the end of the solenoid what will be the direction of current at that end ?
3. What is the voltage of electric current is produced in power stations in India ?
- 4)  What type of mirror is this ?
- 5) Among these which medium has highest optical density
(vacuum, diamond, water, glass)
- 6) Which colour is seen at the upper edge of a rainbow ?
- 7) Find out the relation from the first pair and complete the second one.
Inductor : self induction
Transformer :
- 8) Which fuel is used as cooking gas. ?

SECTION B

Question No. 9-20 carries 2 score each.

- 9) We use safety fuse in electric circuits.
 - a) What is the use of safety fuse ?
 - b) Which alloy is used to make fuse wire ?

10) observe the figure.

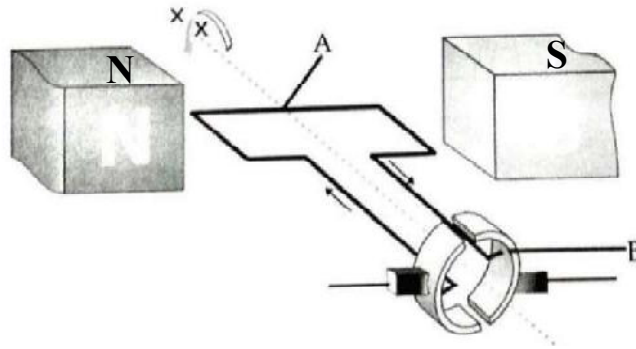

- a) Which is this device ?
- b) Identify the following parts N, S.....

- 11) Write any two first aids given to a person affected by electric shock.
- 12) Write any two peculiarities of the image formed by a concave mirror when the object is at 'C'.
- 13) Write two applications of total internal reflection.
- 14) Which are the colours indicated by A and B in the figure.

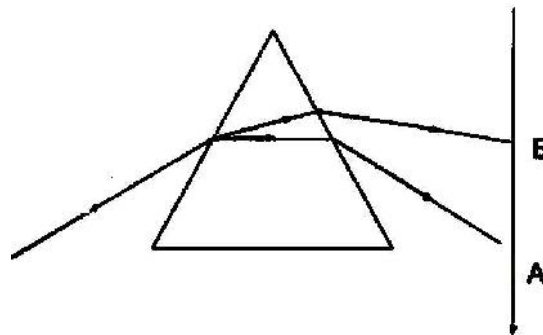

- 15) Classify the following energy sources into green energy and brown energy.
Solar energy, Nuclear energy, wind energy, burning of fuels.
- 16) The conductor AB is in a magnetic field

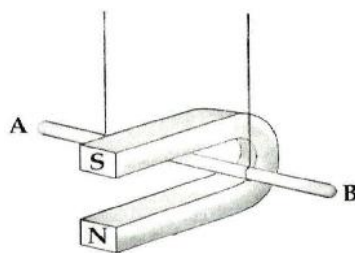

- a) What will be the direction of induced current if the conductor moves outward.
- b) What will be the direction of the movement of the conductor if current passes from A to B.
(Inward the magnet, outwards the magnet)

- 17) a) What is the working principle of a generator ?
 b) What is the energy change in a generator ?
- 18) Power transmission is the transportation of electrical energy from power station to distribution centres using electric lines.
- a) Which type of transformers used at power station ?
 b) How does these type of transformers help in power transmission ?
- 19) Nichrome is used to make heating coil in heating appliances.
 What are the peculiarities of nichrome for this use ?
- 20) The direction of light in various media are given.

Analyse the pictures and answer the questions.

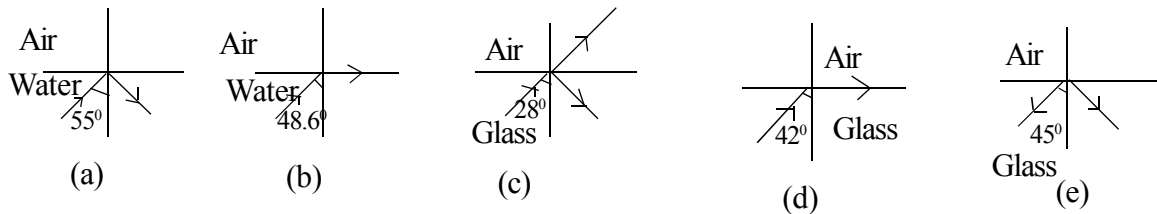

- a) Which are the figures that show total internal reflection ?
 b) What is the critical angle of glass ?

SECTION C

Questions 21- 28 carries three each.

- 21) Calculate heat produced in a 23Ω resistor when 230V potential difference is applied for 5 minutes.
- 22) A magnetic needle deflects when an electrical current passes through a conductor near to it.

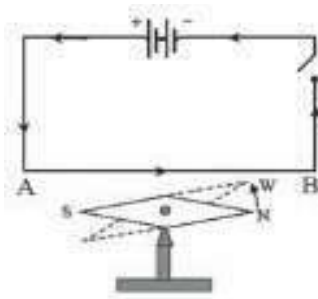

- a) What is the reason for this deflection ?
 b) What is the change in the deflection of the magnetic needle when the direction of the current is changed.
 c) Which law connects the relation between direction of electric current and magnetic field.

- 23) classify the following statements suitable for step up and step down transformer.
- Thin wires used in primary/
 - Thin wires used in secondary
 - No. of turns are less in primary
 - No. of turns are less in secondary
 - Thick wires used in primay
 - Thick wires used in secondary
- 24) An object is placed at a distance of 15 cm in front of a mirror. According to new cartesian sign convention focal length is - 6 cm.
- What type of mirror is this ?
 - Calculate the distance between the mirror and the image.
- 25) Observe the incomplete picture of the formation of a image in a convex lens.

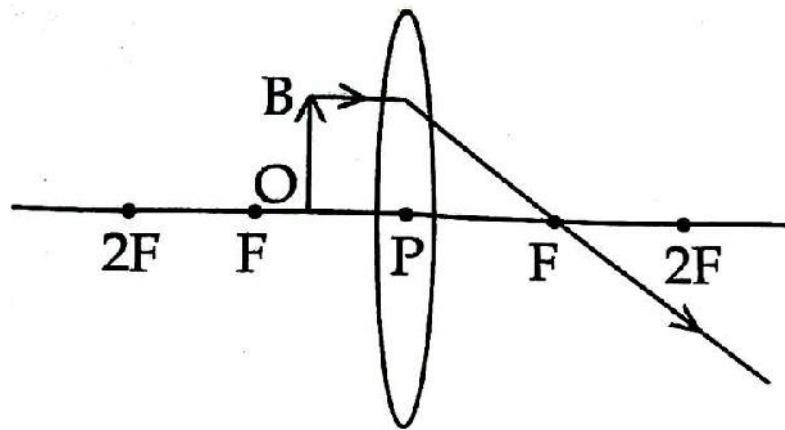

- Complete the ray diagram of image formation.
 - Write the nature and size of the image.
- 26) Define the following terms related to vision
- persistence of vision
 - Near point
 - Power of accommodation
- 27) What is meant by energy crisis. Write two methods to overcome energy crisis.

- 28) Identify and draw the graphs of emf produced by AC generator, Battery and DC generator.

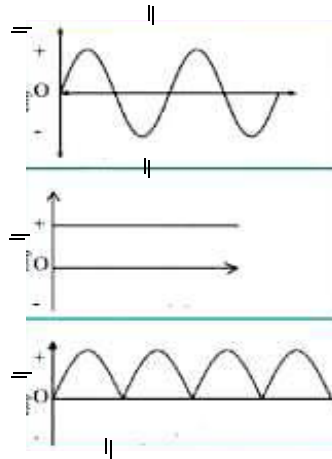

SECTION D

Questions from 29 - 34 carries 4 score each.

- 29) The picture is the two phases of an experiment using a magnet and armature coil. (Picture A Static phase and Picture B dynamic phase).

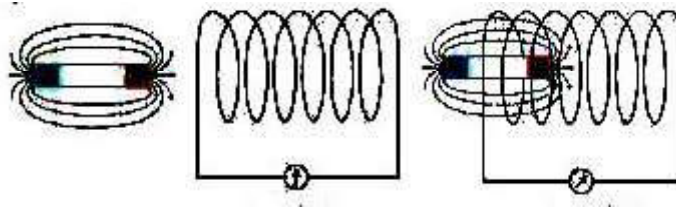

- 1) In which phase galvanometre needle will deflect ?
 - 2) Explain the reason for this deflection with its scientific principle.
 - 3) Write the name of two devices working based on this principle.
- 30) Observe the picture and answer the following questions.

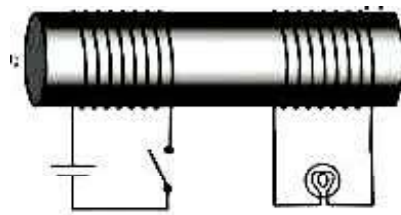

- 1) Switch on the circuit. After some time switch off. What do you observe ?
- 2) Name the coil in which input current is given.
- 3) Name the coil in which output current gets.
- 4) What change will be observed if we use AC instead of cell .

31) Match column A and B suitably.

A	B
1) Bar magnet	a) Split ring commutator
2) Electric Motor	b) Voice coil
3) Solenoid	c) Permanent Magnet
4) Moving coil loud speaker	d) Temporary magnet

32) Light reflects from smooth surface. Observe the picture and answer the questions based on law of reflection.

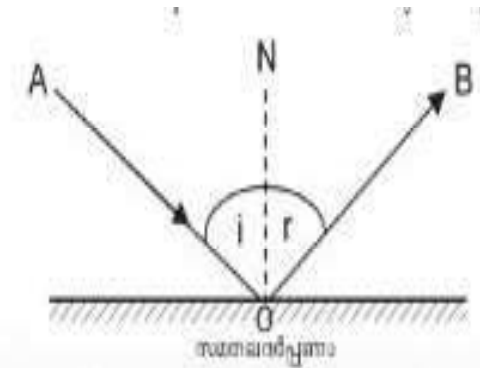

- 1) Incident Ray :
- 2) Reflected Ray :
- 3) If the angle of incidence is 45° What is the angle of reflection ?
- 4) What law is related to it ?

33) Lens is an optical medium with Spherical Surface. Convex lens and concave lens are the common lenses.

Answer the following questions selecting the correct answers from the brackets.

(Principal axis, Optical Centre, Principal focus of convex lens, Focal length, principal focus of concave lens)

- 1) The centre of a lens is
- 2) The line which passes through the optical centre of the lens connecting two centres of its curvature.
- 3) The distance between the optical centre and principal focus.
- 4) Which type of lens has real focus.

34)

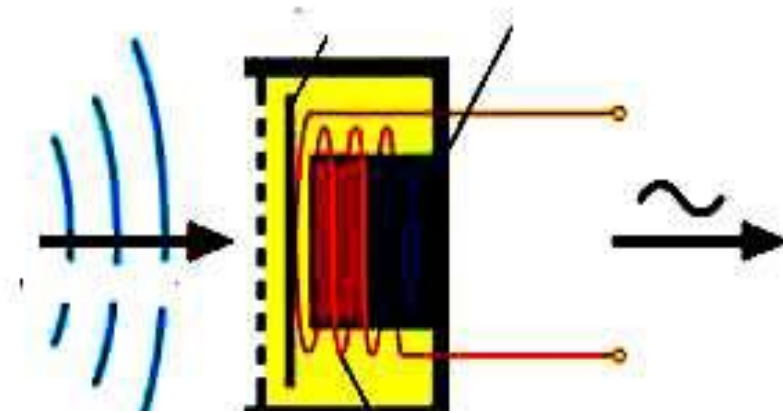

- 1) Identify this device
- 2) What is the working principle of this device
- 3) Which are the main parts of this device.
- 4) What is the energy change in this device.

MODEL EVALUATION TEST 2021

PHYSICS

Standard X

Time: 1 ½ hrs

Maximum Score: 40

General Instructions:

- The first 20 minutes is the cool-off time. You may use this time to read and plan your answers.
 - There are a total of 80 score questions. Out of these, the best written questions / sub-questions of 40 score will be considered for your score.
 - It is not compulsory to answer all questions. But the maximum number of known answers can be written within the time allowed.
 - Write the answers that you can write with confidence first.
 - Write the question number/sub-question number clearly.
-

SECTION A

Questions 1-8 carries 1 score each.

1. Find the relation in first pair and compare the second pair.
Filament Lamp : Tungsten
Fuse wire :, Alloy
2. Select the correct statement related to Fleming's Left Hand Rule.
a) Thumb indicates the direction of motion of the conductor.
b) Forefinger indicates the direction of current.
c) Middle finger indicates the direction of magnetic field.
3. What is the frequency of AC generated for distribution in our country ?
4. Which type of mirror is used as rear view mirror ?
5. When the magnification is more than 1, the size of the image isthe size of the object.
6. Which process is responsible for the production of energy in the stars ?
7. Find the odd one.
Coke, Ammonia, Naphtha, Coal tar
8. Identify the source of Green energy from the following.
a) Coal b) Naphtha c) Biogas d) Petroleum

Section B

Questions 9-20 carries 2 score each.

9. Three resistors of 2 ohm are given. By using this resistors
a) What is the highest resistance that you can get ?
b) What is the lowest resistance that you can get ?
10. Write any two disadvantages of incandescent lamps.
- 11) a) Which are the main parts of a moving coil loud speaker ?
b) Mention the working principle of moving coil loud speaker.
12. Write any two factors which affecting the strength of the magnetic field of a solenoid carrying current.

13. When the armature of an AC generator rotates in the magnetic field, current induced in it.
 - a) Which rule is used to find the direction of induced current ?
 - b) According to this rule the forefinger indicates
14. Write the similarities and difference in the structure of AC generator and DC generator .
15. When Anitha observed her face through two different mirrors, the size of the image of the face different in both mirrors. Based on this change identify the mirrors.
 - a) Same size as that of the face.
 - b) Size of the image of face is large. (Magnified)
16. Observe the figure and answer the question below.

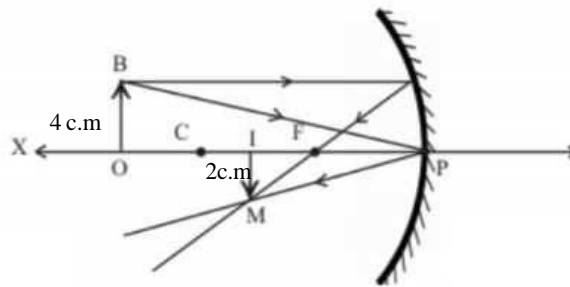

- a) Height of the image
 - b) Height of the object
17. Observe the following figures related to refraction of light.

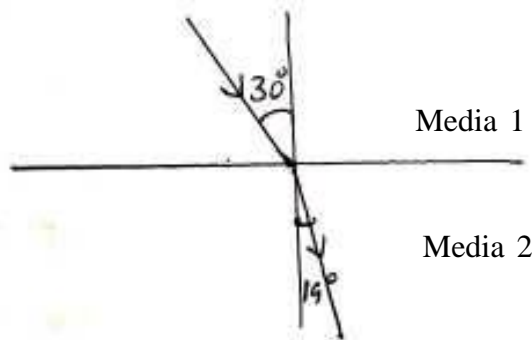

- a) Find out the incident angle and the refracted angle from the figure ?
 - b) What happens to the path of the light, when light ray passes obliquely from the air to glass ?
18. Why sun appear red in sunrise and sunset ?
 19. LPG is used as cooking gas for domestic purpose ?
 - a) What is the full form of LPG ?
 - b) Which is the main component of LPG ?
 20. Write any two method for reducing energy crisis ?

Section C

Questions 21-28 carries 3 score each.

21. Which are the peculiarities of Nichrom that make it suitable for using in heating appliances ?
22. Match the following.

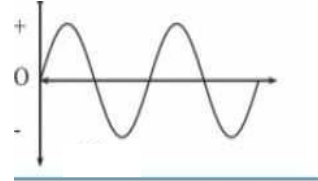
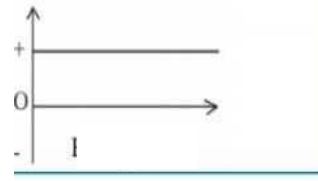
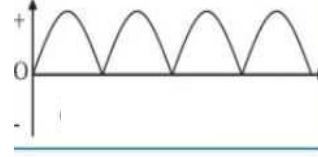
A	B	C
	Battery	emf increases and decreases without change in direction
	DC Generator	Direction of emf changes continuously
	AC Generator	emf is steady

23. Free Moving Conductor AB in a magnetic

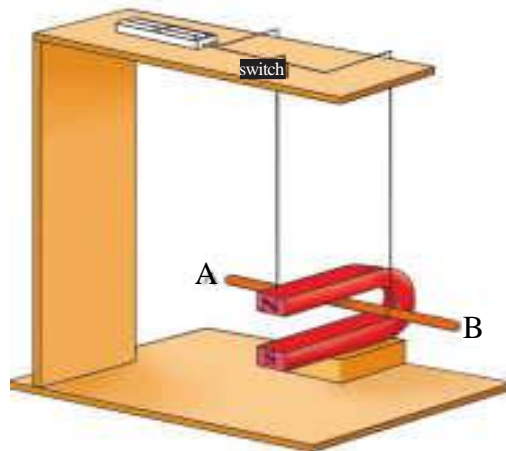

- a) What happens when electricity pass through the conductor
 - b) What is the reason for it ?
 - c) What happens when the direction of electric current reverse. Why ?
24. When an object is placed 30 cm away from a sperical mirror the magnification is -1.
- a) What are the feature of the image ?
 - b) Which type of mirror is this ?
 - c) When an object is placed 10 cm away from the mirror what changes will occur to the nature of the image.

25. When a person consulted an ophthalmologist, he wrote in his prescription as +2D.
- What does +2D indicates ?
 - Which type of lens is this
 - What is the focal length of this lens ?
26. The nature of the images formed by the two lenses are given below.
- Erect and magnified virtual image.
 - Erect and diminished virtual image.
- Which type of lens is used in each case ?
 - By using which type of lense an image of the size as that of the object can be created. In this case where is the position of the object ?
- 27) Red light uses in signal lamps and tail lamps of vehicles.
- Which has highest wave length in the visible spectrum ?
 - What is the relation between wave length and scattering of light ?
 - Why red light use in signal or tail lamps ?
- 28) a) Which colour is seen when a Newtons colour disc rotates fast ?
- What is the phenomenon behind this ?
 - Write another situation in which this phenomenon is applied.

Section D

Questions 29-34 carries 4 score each.

29. An object is placed in front of a lens.

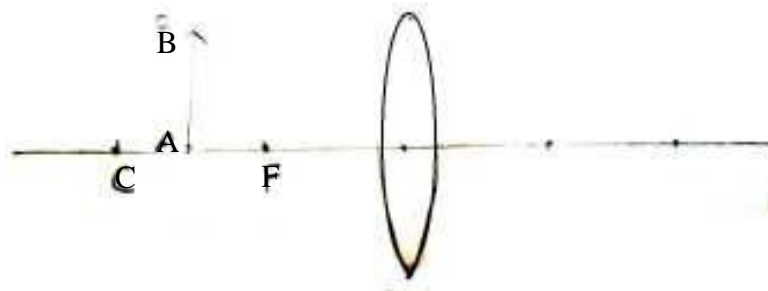

- Identify the lens
- Complete the diagram and find out the position of image.
- Write two features of the image.

30. The diagram indicates the image formation in the eye of a distant object.

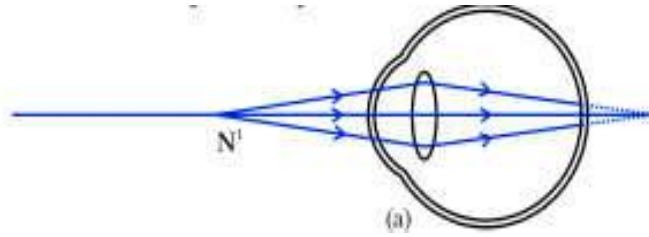

- Identify the defect of the eye.
- Write two reasons for this defect.
- Which type of lens is used to rectify this defect.
- Draw the figure of the correction of this defect.

31.

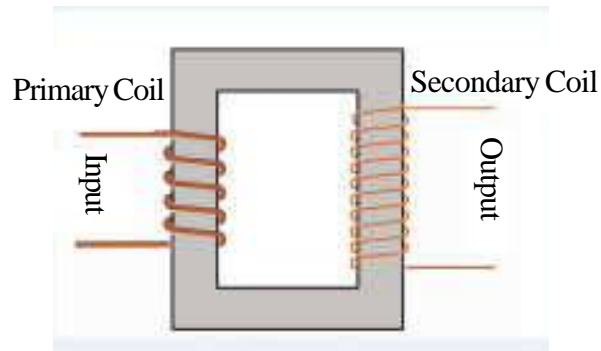

Identify this device.

- What is the working principle of this device ?
- The input voltage is 240V. The number of turns in primary is 800 and that of secondary is 80.
What will be output voltage.

32. Observe the figure and answer the questions.

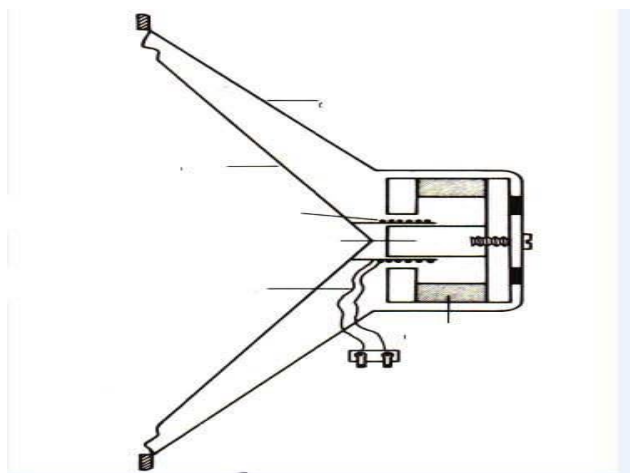

- a) What happens when the coil vibrates ?
- b) What will happen when steady current reaches the voice coil ? Give reason ?
- c) What is the working principle of this device ?
- d) What is the energy change in this device ?

33. When an object is placed 30 cm away from a concave mirror, an image is formed in a screen at a distance of 20 cm in front of the mirror.

- a) Find out the focal length of the mirror.
- b) Write any one situation in which convex and concave mirrors are used.

34. Match the following

A	B
a) Electric Heater	Light effect
b) Microphone	Heat effect
c) Bulb	Not harmful to environment
d) LED	Electro magnetic induction