

ಕರ್ನಾಟಕ ಪ್ರೌಢಶಿಕ್ಷಣ ಪರಿಷತ್ ಮಂಡಳಿ

ಮಲ್ಲೇಶ್ವರಂ, ಬೆಂಗಳೂರು-560003.

KARNATAKA SECONDARY EDUCATION EXAMINATION BOARD

Malleshwaram, Bengaluru – 560003.

2020-21 MODEL PAPER - 2

Subject : MATHEMATICS

Time : 3 hrs. 15 minutes

Subject Code : 81E

Max. Marks : 80

English Medium

Regular Fresh

General Instructions to the Candidate :

1. This question Paper consists of objective and subjective types of 38 questions.
2. This question paper has been sealed by reverse jacket. You have to cut on the right side to open the paper at the time of commencement of the examination. Check whether all the pages of the question paper are intact.
3. Follow the instructions given against both the objective and subjective types of questions.
4. Figures in the right hand margin indicate maximum marks for the questions.
5. The maximum time to answer the paper is given at the top of the question paper. It includes 15 minutes for reading the question paper.

- I. Four alternatives are given for each of incomplete statement / questions. Choose the correct answer and write the complete answer along with its letter of alphabet. 8 x 1 = 8

1. The Pair of lines $a_1x+b_1y+c_1=0$ and $a_2x+b_2y+c_2=0$ are intersecting lines then the ratio of their coefficients is :

A. $\frac{a_1}{a_2} \neq \frac{b_1}{b_2}$

B. $\frac{a_1}{a_2} = \frac{b_1}{b_2} \neq \frac{c_1}{c_2}$

C. $\frac{a_1}{a_2} = \frac{b_1}{b_2} = \frac{c_1}{c_2}$

D. $\frac{a_1}{b_2} = \frac{b_1}{a_2}$

2. 2, x, 14 are in Arithmetic progression, then the value of x is :

A. 28

B. 16

C. 7

D. 8

3. The standard form of quadratic equation is :

A. $ax^2-bx+c=0$

B. $ax^2+bx+c=0$

C. $ax^2-bx-c=0$

D. $ax^2+bx-c=0$

4. $\sin(90-\theta)$ is equal to :

A. $\cos \theta$.

B. $\tan \theta$.

C. $\sec \theta$.

D. $\cot \theta$.

5. The value of $\tan 45^\circ$ is :

A. $\sqrt{3}$

B. 0

C. 1

D. $\frac{1}{\sqrt{3}}$

6. In the given graph. The co-ordinate of point A is :

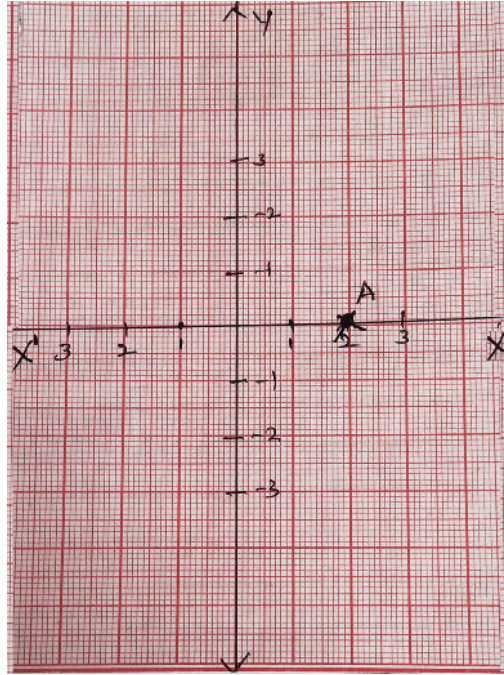

- A. (-1, 0)
- B. (1, -1)
- C. (0, 2)
- D. (2, 0)

7. The empirical relationship between the three measures of central tendency is :

- A. $2 \text{ Median} = \text{Mode} + 3 \text{ Mean}$
- B. $3 \text{ Median} = \text{Mode} + 2 \text{ Mean}$
- C. $\text{Median} = \text{Mode} + \text{Mean}$
- D. $\text{Median} = \text{Mode} - \text{Mean}$

8. In the given figure $ST \parallel QR$ then $\frac{PS}{SQ}$ is equal to :

- A. $\frac{PT}{TR}$
- B. $\frac{PS}{TR}$
- C. $\frac{PT}{SQ}$
- D. $\frac{PT}{SR}$

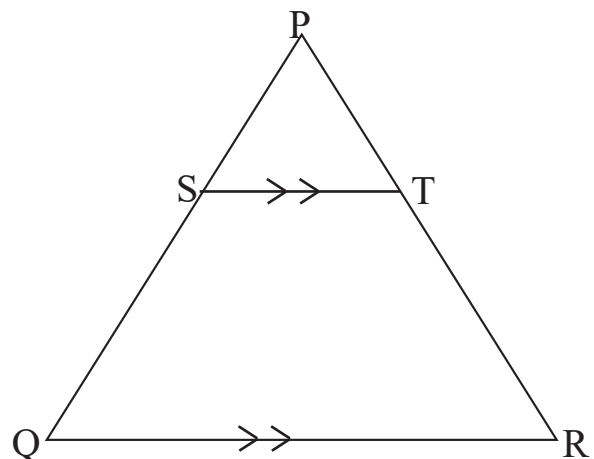

II. Answer the following questions.**8 x 1 = 8**

9. In equation $x+y=7$, if $x=3$, then find the value of y ?

10. In the given figure "P" is a midpoint of BC, write the formula to find the co-ordinate of P ?

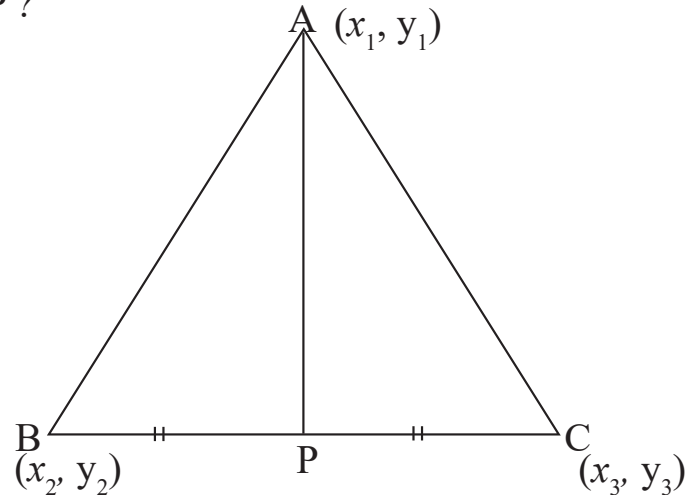

11. Write the measure of angle formed between tangent to a circle and radius drawn from the centre of the circle to the point of contact of the tangent.

12. Write the formula to find the total surface area of a right cylinder ?

13. Write the formula to find the volume of a solid sphere ?

14. Write the mathematical relation between slant height (l) height (h) and radius (r) of a cone ?

15. In an arithmetic progression if $a_n = 3n-2$, then find the second term of the progression.

16. If, $15 \cot A=8$, then find the value of $\tan A$?

III. Answer the following questions.**8 x 2 = 16**

17. Solve by using elimination method ?

$$x + y = 8$$

$$2x - y = 7$$

18. Find the 10th term of arithmetic progression 2, 7, 12 using the formula.

19. Find the sum of $2+5+8+\dots$ to 20 terms using the formula.

20. Find the discriminant of the equation $3x^2 - 5x + 2 = 0$ and hence write the nature of its roots.

21. Solve $x^2 - 2x + 3 = 0$ by using the quadratic formula.

OR

Solve by Factorisation $x^2 + 5x + 6 = 0$.

22. Find the distance between the points A(3, 6) and B(5, 7) using distance formula.

OR

Find the co-ordinates of the point P, which divides the line joining A(0, 0) and B(5, 10) in the ratio of 2:3.

23. Construct a tangent to a circle of radius 4cm at any point P on its circumference.

24. In the given figure, find the value of $\sin \alpha + \cos \theta$?

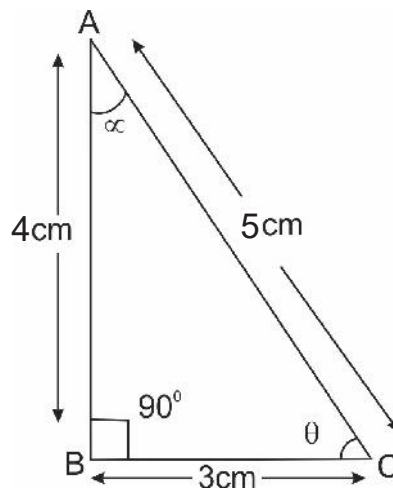

IV. Answer the following questions.

9 x 3 = 27

25. A train travels 480 km at a uniform speed. If the speed had been 10km/h more, it would have taken 4 hours less for the same journey, find the speed of the train?

OR

Find two consecutive odd positive integers, sum of whose squares is 290.

26. Prove that $\{\text{Cosec}(90-\theta) - \text{Sin}(90-\theta)\} \{(\text{Cosec}\theta - \text{Sin}\theta)(\tan\theta + \cot\theta)\} = 1$

OR

Prove that $\frac{(\text{Sin}\theta - \cos\theta)}{(\text{Sin}\theta + \cos\theta)} + \frac{(\text{Sin}\theta + \cos\theta)}{(\text{Sin}\theta - \cos\theta)} = \frac{2}{(2\text{Sin}^2\theta - 1)}$

27. From the top of a building $50\sqrt{3}$ M high the angle of depression of a car on the ground is observed to be 60° . Find the distance of the car from the Foot of a building.

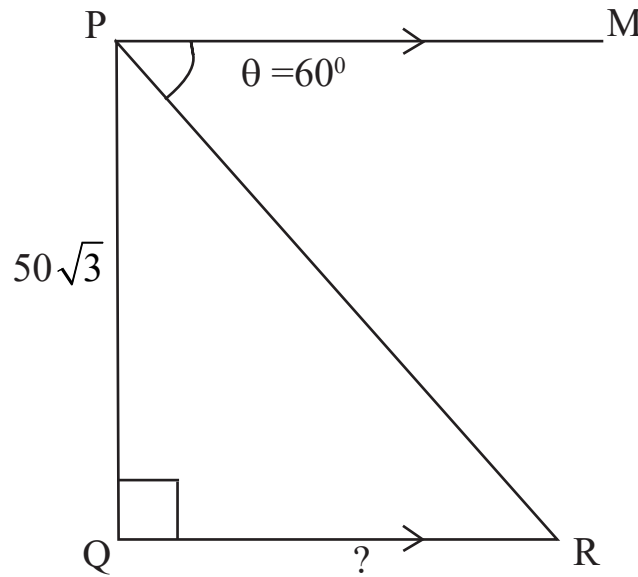

28. Find the area of triangle ABC, whose co-ordinates are A(4, -6), B(3, -2) and C(5, 2) then find the length of the median AD?

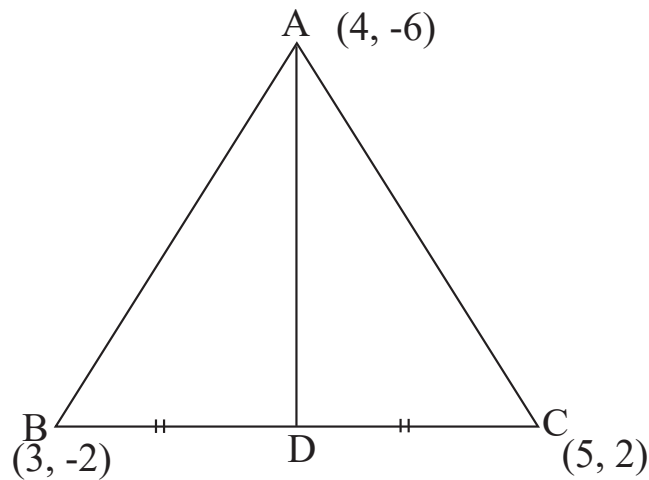

29. Find the mean of the following data, by direct method.

Class interval	Frequency
1 - 5	4
5 - 9	3
9 - 13	5
13 - 17	7
17 - 21	1
	N = 20

OR

Find the mode of the following data.

Class interval	Frequency
0 - 10	6
10 - 20	9
20 - 30	15
30 - 40	9
40 - 50	1
	N = 40

30. Prove that “length of tangents drawn from an external point to a circle are equal.
31. The slant height of a frustrum of a cone is 4cm and perimeters of its circular bases are 18cm and 6cm, find the curved surface area of the frustrum of a cone.

OR

The circumference of the base of a cylinder is 132cm and its height is 25cm. Find the volume of the cylinder?

32. Draw a “less than type ogive” for the data given in the following table.

Class interval	Frequency
0 - 10	2
10 - 20	12
20 - 30	2
30 - 40	4
40 - 50	3

33. Construct tangents to a circle of radius 5cm such that the angle between the tangents is 60° .

V. Answer the following.

4 x 4 = 16

34. Find the Solution to the given pair of linear equations by graphical method.

$$x + y = 5$$

$$2x - y = 4$$

35. The third term of an arithmetic progression is 8 and its ninth term exceeds three times the third term by 2 find the sum of the first 19 terms.

OR

In an arithmetic progressive the sum of the three terms is 24, and their product is 480, write three terms of the arithmetic progression?

36. A toy is in the form of a cone mounted on a hemisphere with the same radius is as shown in the figure. If the diameter of the conical portion is 6cm and its height is 4cm, then find the surface area of the toy.

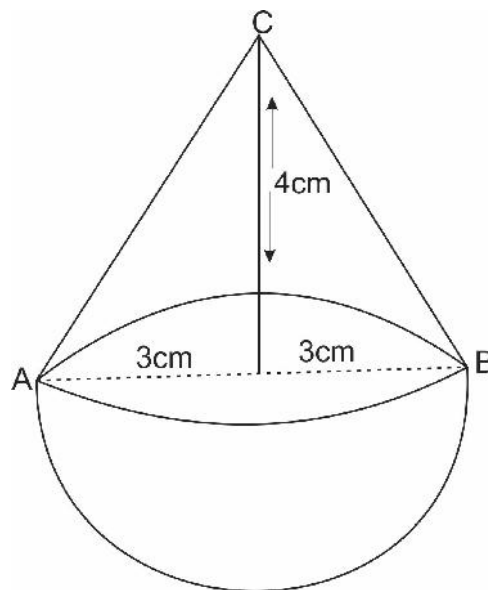

37. Construct a triangle ABC of its sides $BC=4\text{cm}$, $AB=6\text{cm}$ and $AC=4.5\text{cm}$ then construct a triangle similar to it, whose sides are $\frac{2}{3}$ of the corresponding sides of the triangle ABC.

VI. Answer the following question.

1 x 5 = 5

38. State and Prove “Basic proportionally theorem”