

LIVING WORLD

- Unit of classification is _____.
 (a) Taxon (b) Species
 (c) Genus (d) Cell (HSE-March 2020) (1)
-is the taxonomical aid based on contrasting characters generally in a pair called couplet. (HSE-july-2019)(1)
- Binomial nomenclature was proposed by (HSE-March-2019)(1)
- Given below the scientific name of frog. Identify the correctly written name
 a) *Rana Tigrina*
 b) *Ranol tigrina* (HSE-Model-2019)(1)
- Which among the following represents the CORRECT sequence? . (HSE-Aug-2018)(1)
 a) Kingdom ← Phylum ← Class ← Family ← Order ← Genus ← Species.
 b) Phylum ← Class ← Kingdom ← Order ← Family ← Species ← Genus
 c) Kingdom ← Phylum ← Class ← Order ← Family ← Genus ← Species
 d) Kingdom ← Phylum ← Class ← Family ← Genus ← Order ← Species
- Rearrange the following taxonomic categories in the correct sequence. (HSE-March-2018)(1)
 Kingdom ← Class ← Phylum ← Genus ← Family ← Order ← Species
- ICZN stands for (HSE-model-2018)(1)
 a) International Council of Zoological Nomenclature
 b) Indian Council of Zoological Nomenclature
 c) International Code of Zoological Nomenclature
 d) IndianCode of Zoological Nomenclature
- Find out the odd one on the basis of taxonomy and justify your answer (HSE-July-2017)(1)
 a) Family b) Order c) Class
 d) Herbarium e) Phylum
- Select the correct sequence of taxonomic hierarchy. (HSE-March-2017)(1)
 a) Kingdom-Phylum-class-order-genus-family-species
 b) Kingdom-phylum-order-class-family-genus-species

- Kingdom-Phylum-class order-Family-Genus-Species
- Kingdom- Class- Phylum- Family- Order- Species-Genus
- Observe the first pair of words and write a suitable word for the second pair
 Botanical garden : Living plants
: Living animals (HSE Sept-2016)(1)
- During adventure trip a plus one student got a skull and skeletal part of rare animal from the Chinnar forest. Select suitable location for keeping it from the list taxonomical aids given below (HSE March-2016)(1)
 (Herbarium, museum, zoological park, Botanical garden)
- A student conceived the rules of nomenclature as follows. If you find any mistake in the underlined portions, correct them with appropriate words (HSE September-2015) (1)
 a. The first word in a biological name represent species and begins with a Capital letter
 b. The second word represents Genus and begins with a small letter
- Complete the tale using suitable terms (HSE MARCH-2015) (1)

Common name	Genus	Species	Class	Phylum
Man		Sapiens	Mammalia	

- Select the correct Generic name and specific epithet from the table given below and write the scientific name of House fly (HSE AUGUST-2014) (1)

Generic name	Specific epithet
<i>Mangifera</i>	<i>domestica</i>
<i>Musca</i>	<i>indica</i>

- Align the taxonomical categories in the ascending order. (HSE MARCH-2014)(1)
 (Genus, order, phylum, species, family, class, kingdom)
- Rearrange both the biological category and taxon based on taxonomical hierarchy

(Hint-The last two terms of taxon will give the scientific name of house fly)

Category	Taxon
Phylum	Musca
Genus	Insecta
Class	Arthropoda
Species	Domestica

17. After completing a project study based on diversity of spiders, the specimens were intended to be stored for future reference. Select a suitable taxonomical aid from the following for the preservation of specimens
(HSE MARCH-2013) (1)

a) Herbarium b) Museum
c) Zoological park d) Sanctuary
Justify your answer

18. Categorize the following terms into two. Give suitable title for each category.
(HSE-SEPTEMBER-2012)(1)

Species, museum, class, genus,
zoological park, herbarium

19. Taxonomical aids are very useful for classification and identification of organisms. Name any two taxonomical aid
(HSE MARCH-2012)(1)

20. Note the relationship between the first two words and suggest suitable word for the fourth place
(HSE MARCH-2011) ($2 \times \frac{1}{2} = 1$)

a. Collection of living plants : botanical garden, animals kept in protected environment:

b. *Homo sapiens* :Man,
Musca domestica :.....

21. Rearrange the following in correct taxonomic hierarchical sequence (HSE MARCH-2010) (1)
Sapiens-> Hominidae-> Homo->
Mammalia-> Primata-> Chordata

22. Raju collected a skull of animal and a living rare animal during a study tour. Select the suitable location for each from the list given in the brackets
(HSE MARCH-2009)(1)

(Botanical garden, Zoological park, Herbarium, Museum)

ANIMAL KINGDOM

- Identify the word pair applicable to phylum ctenophora. (HSE-March-2020)(1)
 - (a) Nephridia, Parapodia
 - (b) Comb plates, Bio luminiscent
 - (c) Polyp, Metagenesis
 - (d) Radula, Visceral hump
- Characteristics of certain animals are given. Arrange them under the 'Class' to which these animals belong. (HSE-March-2020)(2)
 - (i) Skin is moist without scales.
 - (ii) Body is covered by dry and cornified skin.
 - (iii) Shed the scales as skin cast.
 - (iv) Can live in aquatic as well as terrestrial habitats
- Observe the figures. (HSE-March-2020)(3)

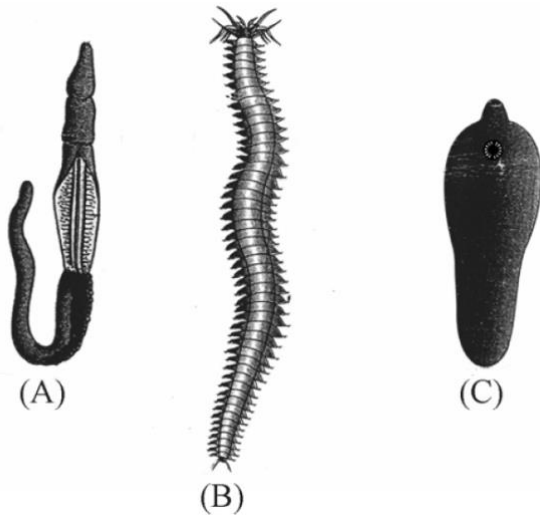

- Identify the organisms A, B & C.
 - Name the phylum to which each of them belong
- Unlike bony fishes cartilage fishes are swim constantly to avoid sinking due to the -
 - (a) Presence of pharyngeal gill slits
 - (b) Presence of air bladder
 - (c) Absence of pharyngeal gill slits
 - (d) Absence of air bladder (HSE-July-2019)(1)
 - The following are organs of certain animals :
 - parapodia
 - Flame cells
 - proboscis gland
 - Comb plates
 - (a) Select organs helps in excretion.
 - (b) Name the organism bearing these organs and write its phylum. (HSE-July-2019)(2)
 - Complete the Schematic diagram. (HSE-July-2019)(3)

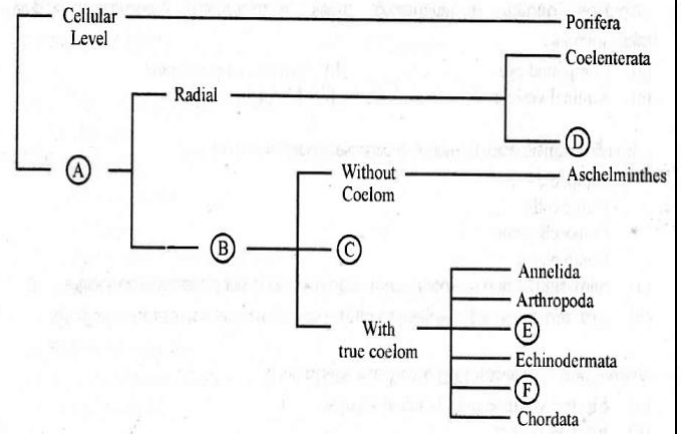

7. Complete the flowchart given below.

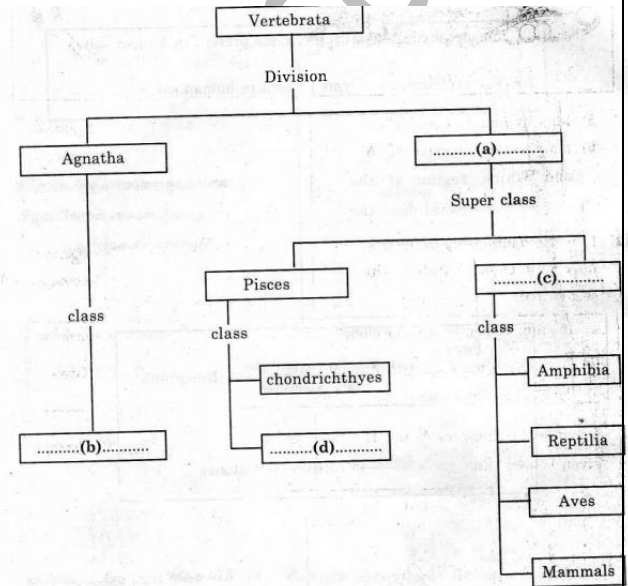

(HSE-March-2019)(2)

- "All vertebrates are chordates but all chordates are not vertebrates". Do you agree with this statement? Substantiate (HSE-March-2019)(2)
- Find the odd one from each group. Justify your answer. (HSE-July-2019)(3)

a) Star fish, Devil fish, Dog fish, Jelly fish
b) Flying fish, Angel fish, Saw fish, Fighting fish
c) Sea lily, Sea cucumber, Sea hare, Sea urchin

10. Observe the figure of the given organism



- Identify the organism
- Name and the class in which it belongs.
- Mention any two salient features of the class.

11. Note the relationship between two words and find a suitable word for the fourth Place
 a) Colenenterate : Radial symmetry
 Platyhelminth :
- b) Lizard : Poikilothermous
 Crow :
12. Which of the following animal exhibit metagenesis?
 (HSE-Model-2019)(1)
 Ascaris, Obelia, Earthworm, Crab
13. Who am I?
 (HSE-Model-2019)(2)
 1 live in sea
 2 respire through gills
 3 excrete by proboscis gland
 4 My body consists of proboscis, collar and trunk.
 a) Identify the phylum.
 b) Give one example from the phylum
14. From a fish market, you got a fish, on a close watching your friend says it is a cartilaginous fish.
 a) Which characters helped him to identify it as a cartilaginous fish (any four characters) ?
 b) Name the class it belongs
 (HSE-Model-2019)(2)
15. Note the relation in the first pair and then complete the second pair. (HSE-Aug-2018)(1)

<i>Fasciola</i>	:	Liver fluke
<i>Taenia</i>	:?.....

16. Find out the odd one and justify your answer
 (HSE-Aug-2018)(2)
 Saw Fish, Jelly fish, flying fish,
 Angel Fish, Dog Fish
 Name of certain animals are given below. Write the phylum of each animal. (HSE-Aug-2018)(2)
 a) Pila
 b) Pleurobrachia
 c) Nereis
 d) Balanoglossus
17. Observe the diagram showing the characteristics of a phylum (HSE-Aug-2018)(3)

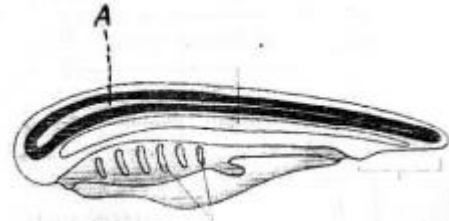

- a) Identify the Phylum
 b) Name the Part labeled 'A'
 c) Point out the three fundamental characters of the phylum.
18. Note the relationship in the first pair and then complete the second pair.
 Osteichthyes : Cycloid scales
 Chondrichthyes :
19. Arrange the following terms under two headings based on symmetry (HSE-March-2018)(2)
 Arthropods, Ctenophores, Molluscs, Coelenterates
20. a) A table showing examples of vertebrates given below. But some of the examples are wrongly given. Identify and rearrange it.
 (HSE-March 2018) (3)

Pisces	Amphibia	Reptilia	Aves	Mammalia
Dog fish	Frog	Vulture	Penguin	Alligator
Blue whale	Rohu	Tortoise	Salamander	Flying fox

- b) Which of the above mentioned class is characterised by the presence of pneumatic bone ?
21. Find out the pseudocoelomate animal from the following : (HSE-Model2018)(1)
 Tapeworm, Hookworm, Earthworm. Honey bee
22. a) Identify the organism. (HSE-Model 2018) (2)



- a) Name the class in which it belongs to ?

NAVAS CHEEMADAN

b) Write any one characteristic feature of the class?

23. a) Classify the given organisms under the heading Poikilothermous and homoiothermous.

Rat, Frog, Dog fish, Ostrich

b) Define the terms poikilothermous and homoiothermous (HSE-Model2018)(2)

24. The diagram of an animal is given. Identify its symmetry (HSE-July-2017)(1)



25. Two characters of an invertebrate animal is given (HSE-July-2017)(2)

- a) Jointed appendage
- b) Malpighian tubule

Identify the phylum and write the role of malpighian tubule in it?

26. Observe the following vertebrate classification

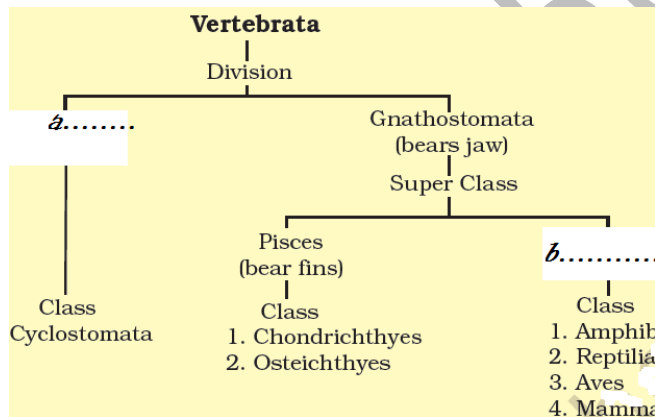

a) Find out a and b

b) Compare any two characters of Chondrichthyes and Osteichthyes?

(HSE-July-2017) (3)

27. Match the items in column B and C with A

(HSE-March-2017)(3)

A	B	C
Phylum/Class	Common example	Unique features
Pisces	Aedes	Presence of hair

SOHSS-AREEKODE

Mammalia	Leech	Open circulatory system
Arthropoda	Felis	Presence of 2 chambered heart
	Scoliodon	Presence of Nephridia

OR

28. Features of different phyla/class are given below. Identify the phylum/class and give examples of each group (HSE-March-2017)(3)

a) Body is covered by scales, heart is 3 or 4 chambered. They respire through lungs

b) They are exclusively marine, commonly called sea walnuts and show Bioluminescence

c) Body is divided into Proboscis, collar and trunk. They have pen circulatory system and presence of proboscis gland.

29. Among the different phyla of animals.....have pseudocoelom (HSE-March-2017)(1)

30. Categorize the following animal under radial symmetry and bilateral symmetry

(HSE-March-2017)(2)

Physalia, Tapeworm, Fasciola, Adamsia

31. Characters of a marine invertebrate is given below

- Spiny skinned body
- Presence of water vascular system

a) Identify and write the phylum?

b) Write any two functions of water vascular system among them (HSE-Sept-2016)(2)

32. a) Identify the cell given in the diagram



NAVAS CHEEMADAN

b) Mention the name of animal phylum based on this cell (HSE-Sept-2016)(1)

33. Two examples of fishes are given below

- Scoliodon (dog fish)
- Exocoetus (Flying fish)

a)Place them in 2 distinct class ?

b)differentiate the above class based on 2 important characters ? (HSE-Sept-2016)(3)

34. The characteristic feature of an invertebrate animal is given

“The phylum include the comb jellies, also called walnuts, they are noted for their bioluminescence and comb plate”

Identify the phylum ? (HSE-March-2016)(1)

35. Fill in the blanks with appropriate words

Osteichthyes : cycloid scale

Chondrichthyes:.....

(HSE-March-2016)(1)

36. Name the phyla in which the following cells or structures or organs are present

- a)Radula
- b)Cnidoblast
- c)Pneumatic one
- d)Proboscis gland (HSE-March-2016)(2)

37. The following diagram shows the characteristics feature of a phylum

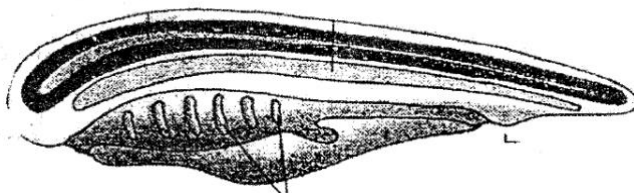

- a)Identify the phylum
- b)Mention four salient features of this phylum? (HSE-March-2016)(2)

38. Observe the following features of animal and answer the following questions

(HSE September-2015) (1)

- Moist skin
- Hooks and suckers
- Pneumatic bones
- Dry and non glandular skin
- Metamerism

a) Select the flight adaptation of birds

navas9895@gmail.com

SOHSS-AREEKODE

b) Select the amphibious adaptations of birds

39. Assign the following features of animals given in the column A to the most appropriate animal phylum given in the column B

(HSE September-2015) (2)

Column A	Column B
a)Metamerism	i)Ctenophora
b)spiny exoskeleton	ii)Platyhelminthes
c)comp plate	iii)annelida
d)flame cell	iv)cnidaria
	v)Echinodermata
	vi)Porifera
	vii)Hemichordata

40. The diagram sketch given below represents hypothetical chordate

(HSE September-2015)(3)

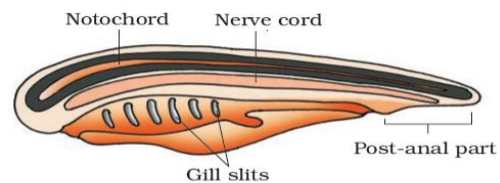

- a. If you find any mistake in the labelled part, copy the diagram and make necessary correction in the labelling
- b. Based on any two labelled parts in the diagram, mention how this phylum differs from non chordates

41. Prawns and insects are included in the phylum arthropoda while they have different habit and habitat. Justify your answer?

(HSE march-2015)(1)

42. Figure (X) and (Y) are the fish of two different classes. Identify them and differentiate between these classes

(HSE march-

2015)(2)

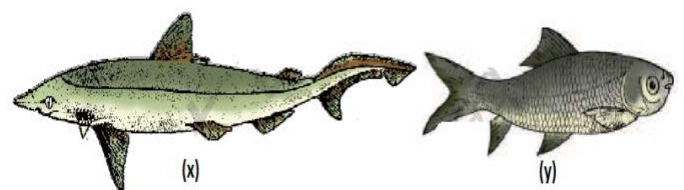

43. Birds are well adapted for flying. Give any 3 of such adaptations?

(HSE march-2015)(3)

NAVAS CHEEMADAN

44. All vertebrates are chordates but all chordates are not vertebrates. Justify this statement with an example?

(HSE march-2015)(3)

45. Find the relationship between the first pair and fill in the blank (HSE august-2014)(1)

Salamander :amphibia

Chameleon :.....

46. In your practical, the class teacher brought the following preserved animals

- a)Balanoglossus b)pila
c)tapeworm d)Physalia

Identify the phylum of each animal and select the distinguishing character of each phylum from the following table

(HSE august-2014)(4)

- 1)Presence of comp plate
- 2)presence of flame cell
- 3)presence of radula
- 4)presence of malpighian tubule
- 5)Presence of probosis gland
- 6)Presence of cnidocyte
- 7)Presence of notochord.

47. "all vertebrates are chordates but all chordates are not vertebrates". Evaluate and substantiate the statement?

(HSE march-2014)(2)

48. Name the distinctive character (Responsible for their names) of the following animal groups (HSE

march-2014)(3)

- a)Cnidaria b)Arthropoda
c)Porifera d)Annelida
e)chordate f)Ctenophora

49. Your biology teacher exhibited a laboratory specimen in the classroom. Based on which feature will you distinguish it as chordate or a nonchordate? (HSE march-2014)(3)

50. Observing starfish in a marine aquarium your friend commented that it is a lower invertebrate without distinct head, eyes and legs.Do you agree with him? Evaluate his statement with reasons?

(HSE october-2013)(2)

51. The following are the key charecterstics of an animal group (HSE october-2013)(2)

- Circular and sucking mouth without jaws
- Fish like body without scales and paired fins

a)Name the class in which this animal belongs

b)Give two example from this class.

52. Frogs, salamanders, Tortoises and crocodiles are seen in both water and land. but they are classified into two different classes of the phylum vertebrate. Evaluate this classification comparing salient features of each class?

(HSE october-2013)(2)

53. a .Pick out the acoelomate organism from the following: (HSE march-2013)(3)

- i)Round worm ii)Hook worm
iii)Filarial worm iv)Tape worm

b. Name the phylum to which it belongs

c. Mention its mode of nutrition

d. What is the coelomic condition of other organisms?

Substantiate your answer

54. During a sea shore visit, a student collected two organisms. Observing the morphology, it is clear that the organisms are radially symmetrical. One of them shows bioluminescence (HSE march-2013)(3)

a)To which phylum does this organism belongs?

b)Identify the possible phyla to which the other organism can e included

c)Which distinctive feature of this organism will help you to categorize it into a particular phylum?

55. Fill in the blanks (HSE september-2012)(1)
Coelomate: arthropoda ;

Pseudocoelomate :.....

56. Is it possible to compare the water vascular system of phylum echinodermata to circulatory system of man in some aspects? Justify your answer? (HSE september-2012)(2)

57. Organisms of this phylum are radially symmetrical, triploblastic, and coelomate with a complete digestive system

(HSE september-2012)(2)

- a) Identify this phylum
- b) Give an example for this phylum
- c) What are the distinctive features of this phylum?

58. Find the relationship between given words and suggests the suitable word for the fourth place

(HSE march-2012)(1)

- a) Annelida : Nephridia
Arthropoda :
- b) Osteichthyes: cycloid scales
Chondrichthyes:

59. Match the column I with II.

(HSE march-2012)(2)

Column I	Column II
a) Cold blooded animal	Platypus
b) Living fossil	Sea cucumber
c) Egg laying mammal	Limulus
d) Water vascular system	Shark
	peacock
	earthworm

60. The following diagram shows the characteristics of a phylum

(HSE march-2012)(3)

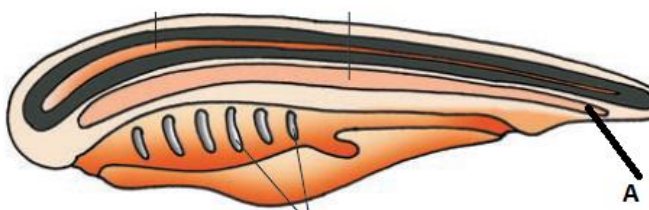

- a) Identify the phylum
 - b) Label A in the diagram
 - c) Mention four salient features of the phylum
61. Complete the column using the appropriate phylum, distinctive features and excretory organs (HSE march-2011)(3)

Phylum	Distinctive features	Excretory organs
Platyhelminthes	a).....	b).....
Arthropoda	c).....	Malpighian tubules
d).....	Body segmentation like rings	e).....
f).....	Water vascular system	Excretory system absent

62. Figure A and B are the fishes of two different classes. Identify and differentiate between these classes (HSE march-2011)(3)

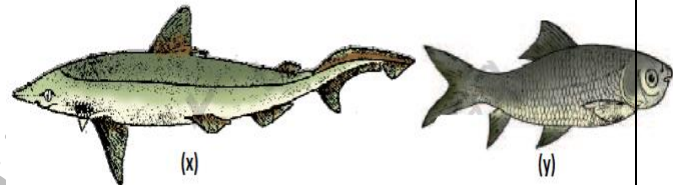

63. Classify the organism below based on segmentation (HSE march-2010)(3)

- a) ascaris b) taenia c) fasciola d) wuchereria
- e) neries f) Pheretima

64. Match Column B and C with Column A

(HSE march-2010)(3)

A	B	C
Reptilia	Feathers	Psittacula
Aves	Mammary glands	Hyla
Mammalia	Parapodia	Chelone
	Scales	Panthera
	Tube feet	Scoliodon

65. Observe the table Given below and fill the blank columns a, b, c and d from the animals given in the rackets (HSE march-2009)(3)

(Hydra, shark, spongilla, Obelia)

Asymmetry	Radial symmetry	Bilateral symmetry
Sycon(a).....(b).....
.....(c).....(d).....	cockroach

66. a. Fill and complete the chart given below

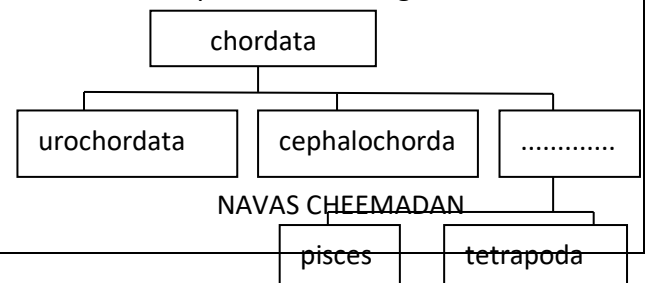

NAVAS CHEEMADAN

SOHSS-AREEKODE

- b. write any two fundamental characters of the phylum chordate
- c. Classify tetrapoda into classes.

(HSE march-2009)(3)

STRUCTURAL ORGANISATION IN ANIMALS

- 'Cockroach is said to be Uricotelic.'
 (a) What do you understand about the nature of excretion of Cockroach from this statement?
 (b) Name two excretory organs of Cockroach.
 (HSE-March-2020)(2)
- Rewrite the given sentences if there is any mistake in the underlined part.
 - Cartilage cells are called osteocycles.
 - Bones are rich in Calcium salts.
 - Intercalated discs are seen in skeletal muscle.
 - Skeletal muscles are striated
 (HSE-March-2020)(2)
- a) Identify the tissues based on the features given below : (HSE-July-2019)(2)
 - Intercalated disc.
 - Involuntary in action
 (b) Mention the function of intercalated disc.
- Identify the function of the following structures of cockroaches (HSE-July-2019)(2)
 - Compound eye
 - Arthrodial membrane
 - Seminal vesicle
 - Malpighian tubules
- Tendons and ligaments are examples of tissue. (HSE-March 2019)(1)
 - Areolar
 - Adipose
 - Dense regular
 - Dense irregular
- Match Column 'A' with Those in columns 'B' and 'C'. (HSE-March-2019)(3)

	A	B	C
a)	Type of simple Epithelium	Location	Function
b)	Squamous Epithelium(a).....	Diffusion
c)(b).....	Ducts of glands and tubular parts of nephrons in kidneys(c).....
d)	Columnar Epithelium(d).....	Secretion and Absorption
e)(e).....	Inner surface of bronchioles and fallopian tubes(f).....

- (a) Name the labeled Parts A, B in the diagram given below (HSE-Model-2019)(2) :

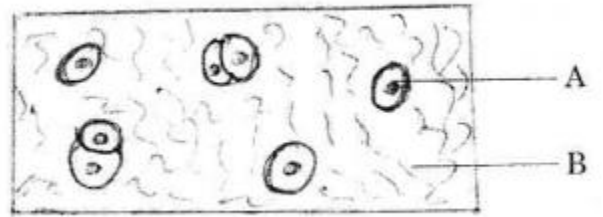

- (b) Which among the following is the bone cell ? (Leucocyte, Chondrocyte, Osteocyte, Thrombocyte)
- Observe the pool of connective tissues carefully, classify them under three headings. (HSE-Model-2019)(2) :

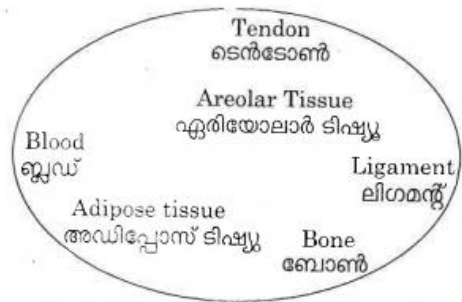

- The mounting of mouth parts of Cockroach are given below. If there is any error, correct it. (HSE-Model-2019)(2)

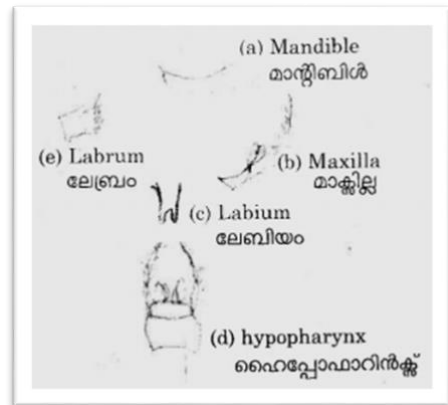

- Observe the diagrams given below (HSE-Aug-2018)(2)

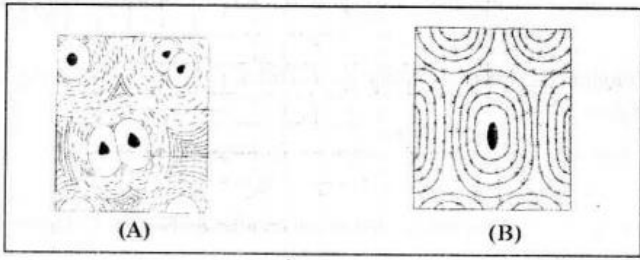

- a) Identify the tissue A and B.
 b) Name the specialized cells present in A and B.
11. a) Among the following body parts squamous epithelium is found in (HSE-Aug-2018)(2)
- the ducts of glands and tubular Parts of Nephron
 - the lining of stomach and intestine'
 - the inner walls of blood vessels and
 - air sacs of lungs
 - the inner surface of bronchioles and fallopian tubes'
- b) Write any one function compound epithelium
12. Identify the following tissues : (HSE-March-2018)(2)
- Tissue that stores fat
 - Tissue that connects bones together
 - 'tissue that connects bones to muscles
 - tissue that conducts impulses
13. Observe the diagram showing the alimentary canal of cockroach. Name the parts labeled A, B, C and D.

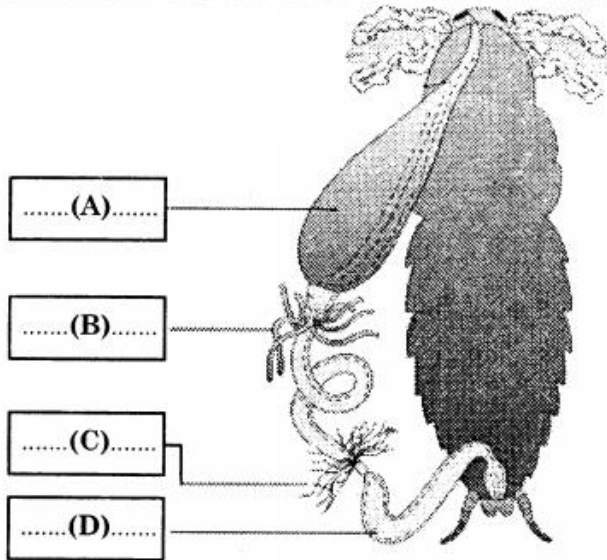

(HSE-March-2018)(2)

14. Bone: Osteocytes :: Cartilage:..... (HSE-Model 2018)(1/2)
15. Identify the figures A and B. Write any one characteristic features of each A and B

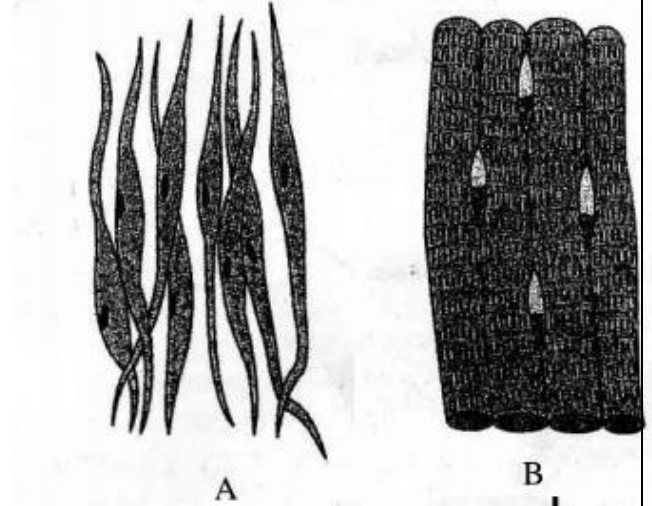

- (HSE-Model-2018)(3)
16. "In cockroaches a special mode of vision is noticed" (HSE-July-2017)(2)
- Write speciality of vision in cockroach
 - Name the organ and its basic units that perform vision in cockroach.
17. Select the connective tissues from the following and write one characters of each tissue

Areolar tissue
Neural tissue
Adipose tissue
Cardiac tissue

(HSE-JULY-2017)(2)

18. In cockroach spiracles are present in.....
- Alimentary canal
 - Tracheal system
 - Malpighian tubule
 - Reproductive system
- (HSE-March-2017)(1)
19. Complete the given branching diagram based on connective tissue (HSE-March-2017)(2)

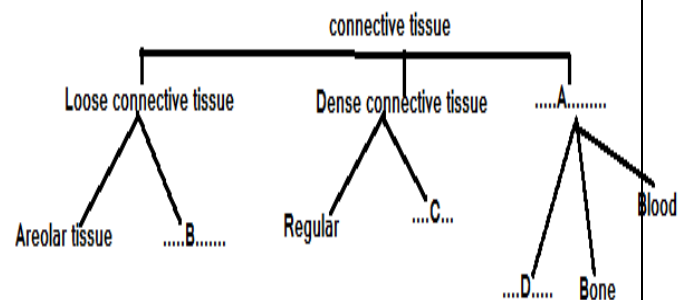

20. a) Identify the given diagram of connective tissue A and B

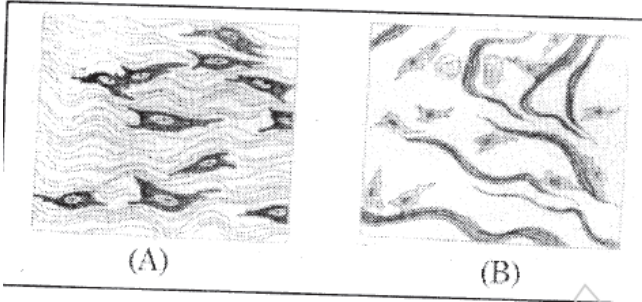

b) Write the location of tissue B in the human body (HSE-Sept-2016) (2)

21. Prepare 2 correctly matching pairs from the given terms (HSE-Sept-2016) (2)

- Ommatidia
- Hepatic caecae
- Genital pouch
- Sense organ
- Excretory organ
- Digestive gland
- Upper lip

22. Observe the following chart and answer the following question (HSE-March-2016) (2)

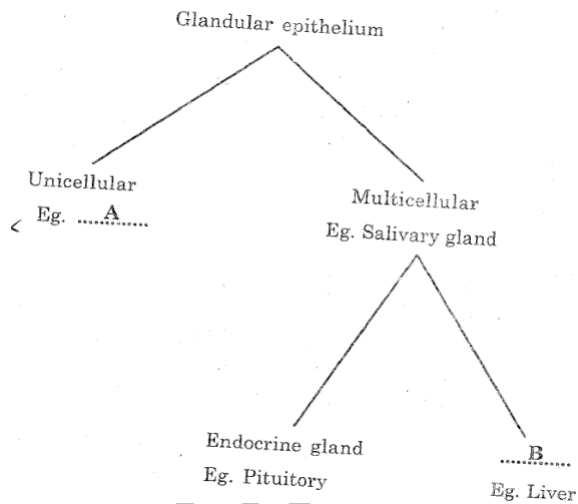

Fill in the missing word A and B

23. Name any two secretions of exocrine glands? (HSE october-2015)(1)

24. Select the odd one out in the following series
 a) Areolar tissue, blood, neuron, tendon
 b) Hypopharynx, malpighian tubule, maxillae, labrum (HSE October-2015)(1)

25. In a laboratory session, your biology teacher exhibited blood smear (slides) of cockroach and human being under microscope. How will you distinguish them based on the nature of plasma and blood cell (HSE october-2015)(2)

26. If the head of cockroach is cut off, it will be alive as long as one week. Give clarification for this statement (HSE march-2015)(1)

27. The diagram below is a simple epithelium (HSE march-2015)(1)

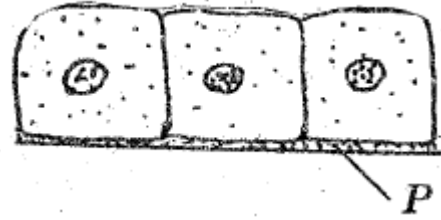

- a) Name the part marked as P
- b) Write one function of simple epithelium

28. The male and female cockroach can be identified by the difference in their morphological features

(HSE march-2015)(2)

- a) Name this phenomenon
- b) give one external difference between male and females

29. Names of two animal tissues are given (HSE august-2014)(2)

- a) cardiac muscle tissue
- b) Adipose tissue
- i) Write the location of these tissues in our body
- ii) Select accurate characters of each tissue from the items given below

1. Cells of this tissues are specialised to store fat
2. Cells of this tissues (Chondrocyte) are seen in small cavities within the matrix
3. presence of intercalated disc

30. Mention the function of the following (HSE august-2014)(1)

- a) Hepatic caeca of *periplaneta Americana*

31. Where do you find the following structure in human body (HSE march-2014)(2)

- a) Collagen fibre
- b) Axons
- c) Squamous epithelium
- d) Smooth muscle

32. Fill in the blanks with suitable terms according to the indicator shown below

(HSE march-2014)(2)

NAVAS CHEEMADAN

Indicators a and b –food habits

C and d-Excretory organ

a)Cockroach :.....

b)Earthworm:.....

c) Cockroach :.....

d)Earthworm:.....

33. Features of a particular tissue visible through a microscopic observation is presented here

(HSE October-2013)(2)

- Cells are closely arranged
- Intercellular matrix absent
- Cells are supported by basement membrane

a) Identify the animal tissue

b) Classify this tissue based on number of cell layers

c) Mention their functions

34. Observe the schematic diagram of a tissue

(HSE September-2012) (2)

a) Identify the type of this tissue

b) The fibres in this tissue help the tissue to perform function. Substantiate

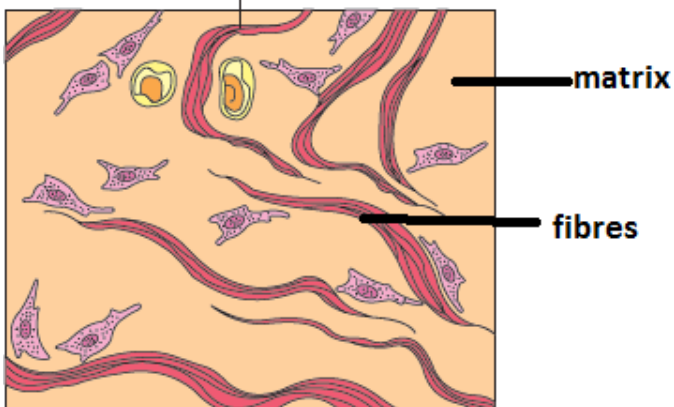

35. Facts related to two types of tissues are given below. Arrange them into two columns by giving suitable headings. Mention the location of each tissue in the human body

(HSE march-2012)(4)

- A sheath of tough connective tissue
- Striations absent
- Bundled together in a parallel fashion
- Fusiform shape
- Involuntary in function

navas9895@gmail.com

SOHSS-AREEKODE

- Striated appearance

36. Observe the following figure. No need to redraw the diagram (HSE-march-2011) (2)

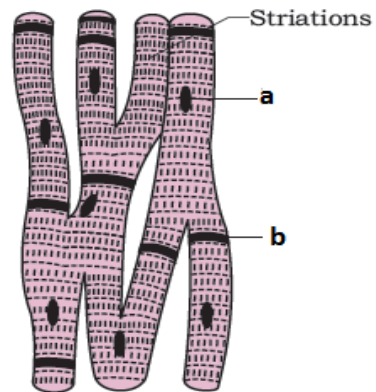

a. Label the parts

a and b

b. Write the functions of b

37. In an informal discussion in your class, your friend made a comment that "malpighian tubules are the kidneys of cockroach ". How will you evaluate this statement?

(HSE March-2010)(2)

38. A schematic sketch representing the alimentary canal of a cockroach is given below. Fill the box with the appropriate organs from the list. No need to redraw the diagram (HSE March -2010) (2)

Crop Salivary gland Gizzard
Rectum Malpighiantubule
Hepatic caeca

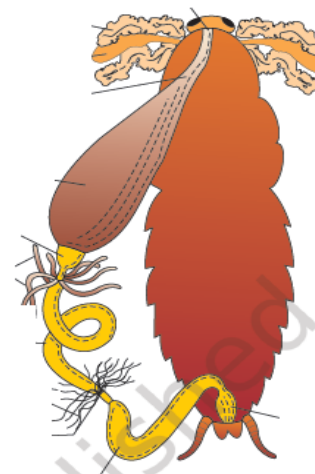

39. Arrange the column A,B,C in the tale below and match them properly (HSE MARCH-2009)

A	B	C
---	---	---

NAVAS CHEEMADAN

Squamous epithelium	Intercalated disc	Present between vertebrae
Cartilage	Dendrite	Helps in gas diffusion in lung
Cardiac muscle	Chondrocyte	Impulse transmission
Neuron	Flattened cells	Helps in heart beat
	Volkman's canal	Antibody formation

40. Frogs and cockroaches shows sexual dimorphism (HSE march-2009)(1)

- a) Write any two morphological differences between male and female cockroach

BIOMOLECULE

1. Which among the following is a primary metabolite ? (HSE-March-2020)(1)

Alkaloids, Antibiotics, Amino acids, Flavonoids

2. When substrate concentration increases, the velocity of enzymatic reaction increases at first. After attaining a maximum velocity, it cannot be exceeded by further addition of substrates. Why ? (HSE-March-2020)(2)
3. Match the following (HSE-July-2019)(3)

Classification of Enzymes	Reactions
A	B
Hydrolases	Oxidation-reduction reaction
Lyases	Linking together of molecules
Oxido-reductase	Transfer of a group
Isomerases	Inter conversion of molecules
Ligases	Removal of groups
Transferases	Hydrolysis of bonds

4. Observe the diagram A and B given below

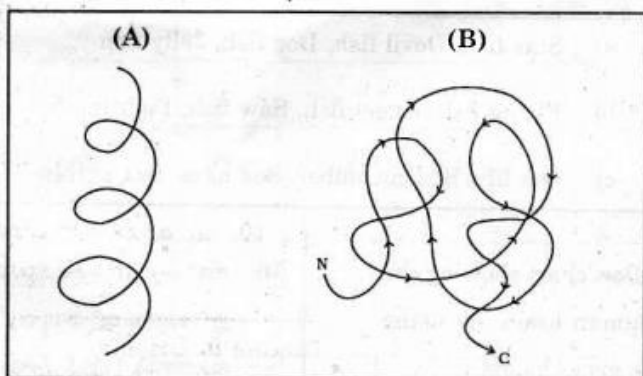

- a) What is 'A' and 'B'?
- b) Mention the other two levels of protein structure (HSE-March-2019)(2)
5. is the most abundant protein in the animal world. (HSE-March-2019)(1)
6. General formula of amino acid is given below (HSE-Model-2019)(3)

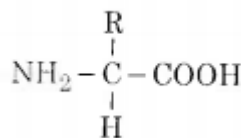

- (a) Prepare the amino acid serine using this formula
- (b) Proteins carry many functions in living organism, list any four.
- (c) Give one word
- (i) The nucleic acid that behave like enzymes
- (ii) The organic compound tightly bound to the apoenzyme
- (iii) The non-protein organic compound that are tightly bound to the apoenzyme
- (iv) The protein part of the enzyme
7. Observe the graph given below (HSE-Aug-2018)(3)

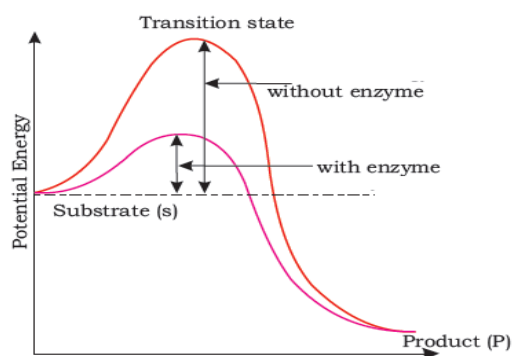

- a) Identify the graph.
- b) Mention the role of Enzyme in this process.
8. The molecular structure of 2 amino acids are given below Name them. (HSE-March-2018)(2)

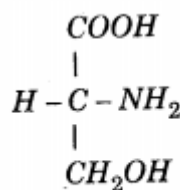

a)

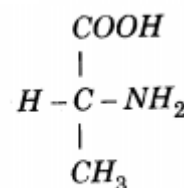

b)

9. a) Complete the diagrammatic representation showing the nature of enzyme action : (HSE-March-2018)(3)

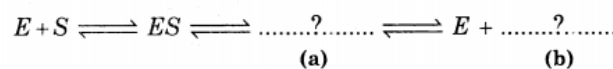

- b) List out any two factors affecting enzyme activity.
- c) Based on the reaction formulae given below, identify the classes of the enzymes.

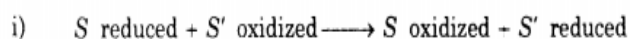

10. a) Effect of change in concentration of substrate on enzyme activity is graphically represented' After reaching a maximum velocity (V_{max})" the reaction is not exceeded by any further rise in concentration of substrate' Explain"
 b) Mention any 2 other factors that affect enzyme activity ? (HSE-Model-2018)(3)

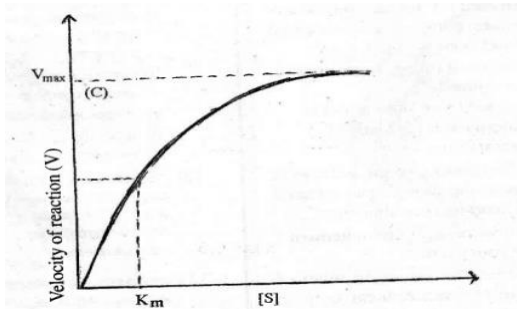

11. Fill in the blanks suitably
 (HSE-Model-2018)(2)

In a proteins aminoacids are linked by(a)...In a polysaccharides individual monosaccharides are linked by.....(b).....

12. Identify the wrong statement from the following and correct it
 (HSE-July-2017)(1)

- a) Lipids are not strictly macromolecule
 b) Cellulose is not a polysaccharide

13. Examples of 2 enzymatic reactions A and B are given. Identify the class of enzyme in A and B

A) S reduced + S' oxidised → S oxidised + S' reduced.

(S,S'- Substrate)

B) S - G + S' → S + S' - G

(S,S'- substrate,G-Group)

(HSE-July-2017)(2)

14. " Proteins is a heteropolymer not a homopolymer " . Substantiate the statement ? (HSE-July-2017)(2)

15. Identify the given biomolecule
 (HSE-march-2017)(3)

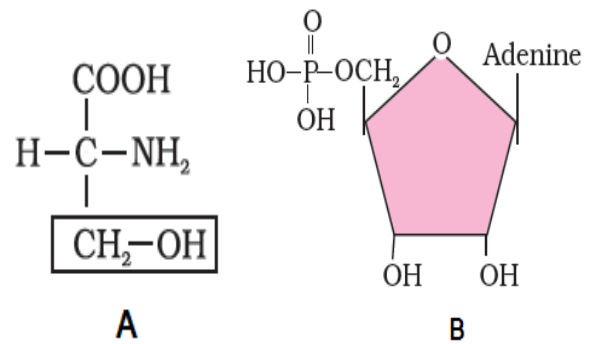

A

B



C

16. Select the wrongly matched pair from the following ? (HSE-March-2017)(1)

Collagen	Intercellular ground substance
Insulin	Hormone
Antiody	Sensory reception
Trypsin	Enzyme

17. Identify the given biomolecule that comes under fat (HSE-sept-2016)(1)

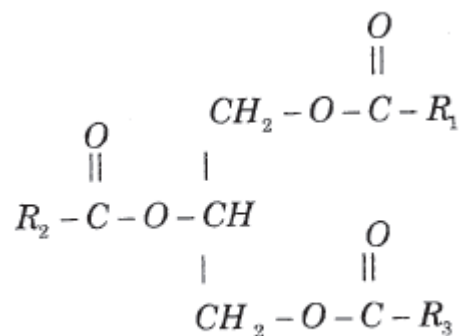

18. a) Name the biomacromolecule (Polymer) in which peptide bond is present ?

- b) Name the bond present between phosphate and hydroxy group of sugar in nucleic acid ? (HSE-sept-2016)(2)

19. Metabolites are organic compounds constantly utilized in various metabolic activities in the cells (HSE-March-2016)(2)

- a)What are the two types of metabolites in the cells?
 b)Give an example for each type of metabolites?

20. Enzymes are biocatalyst which regulate various biochemical reaction

Illustrate the following reaction

(HSE-March-2016)(2)



21. Complete the following sequence with appropriate words

(HSE September-2015)(1)

Amino acids:.....(a).....bond:protein

...(b).....: glycosidic bond : polysaccharide

22. Based on the graph given below, explain the effect of concentration of substrate on enzyme activity

(HSE September-2015)(2)

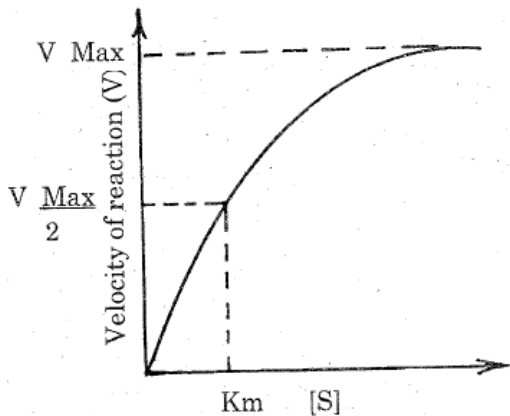

23. Identify the protein structures, (a) and (B) from the following figure

(HSE March-2015)(1)

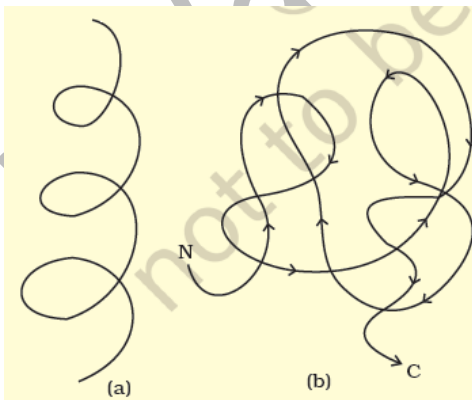

24. Analyze the graph showing the activity of an enzyme, influenced by temperature

(HSE march-2015)(2)

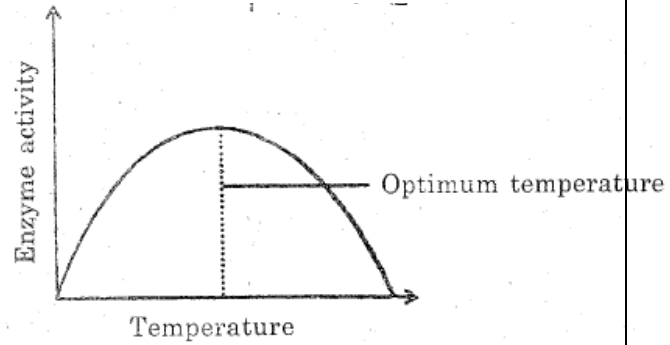

- a)What is meant by optimum temperature?
 b)why does enzyme activity declines at too low and at too high temperature?

5. a. Why are proteins heteropolymers?
 b. Identify the proteins from the given list of iomacromolecule and write its functions (Cellulose, starch, antibody, inulin)
 c. Identify the type of protein structure of a and b (HSE August-2014)(3)

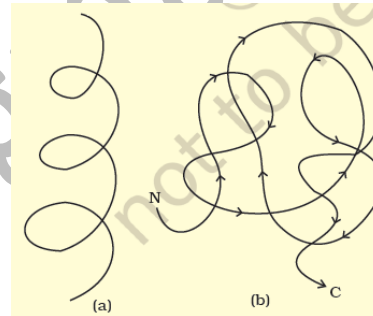

6. Symbolic presentation of a functional enzyme is given below (HSE August-2014)(3)

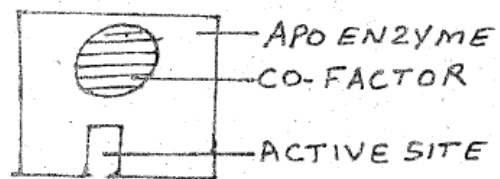

- a. Write one difference between cofactor and apoenzyme?

b. name the different types of cofactor

c. what is the cofactor for the enzyme , carboxypeptidase

7. Name the chemical bond formed between the following (HSE March-2014)(1)

a. Amino acids in a protein molecule

b. Sugar and phosphate in a nucleic acid

8. Distinguish between cofactor and coenzyme with an example for each?

(HSE March-2014)(2)

9. Observe the graph and answer the following
(HSE-SEPTEMBER-2013)(3)

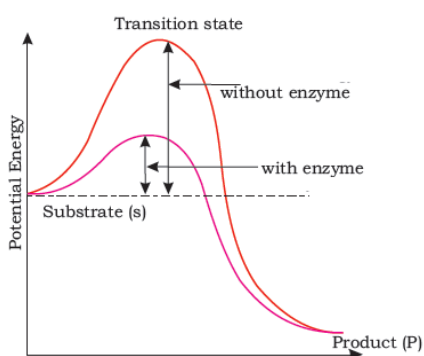

- Find out the role of enzyme?
- Mention any two factors that influence the activity of an enzyme and state their influences?

10.

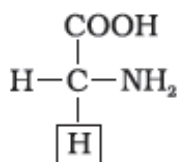

(HSE MARCH-2013)(1.5)

- Identify this compound?
- Name the bond produced when another compound of the same category combine with this?
- If a number of such molecule bonded together, what will be the resultant molecule?

11. Observe the graph showing the activity of an enzyme influenced by pH

(HSE march-2013)(2)

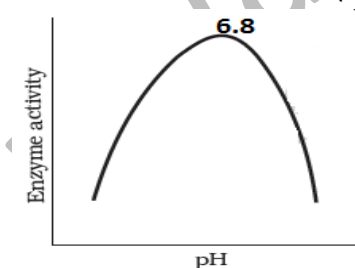

- Name the possible enzyme involved in this reaction?
- Where is its site of action?
- Mention any other factor which affects this enzyme?

d. Name another similar enzyme acting on the same substrate

12. Fill in the blanks

(HSE September-2012)(1)

Carbohydrate : sugar

Proteins:.....

13. Analyse the graph showing the activity of salivary amylase (HSE September-2012)(1)

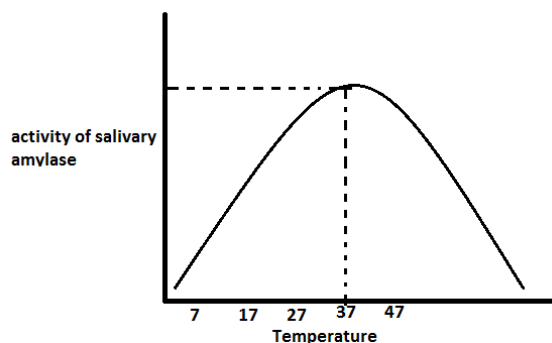

- Which is the optimum temperature for salivary amylase from the graph?
- Why the activity declines below the optimum value?

14. Non protein constituent called cofactor are bound to the enzyme to make the enzyme catalytically active (HSE March-2011)(3)

- Name the protein portion of the enzyme
- What happens to the catalytic activity when the cofactor is removed from the enzyme?
- Mention any two kinds of cofactor with examples?

15. Observe the graph

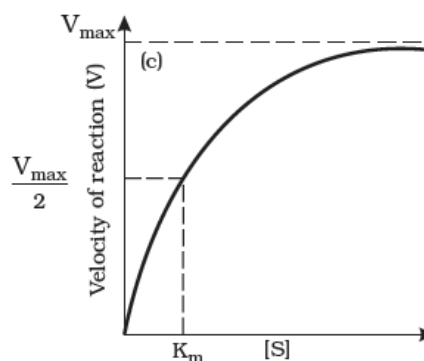

(HSE-March 2010)

- What is meant by 'V_{max}' value?
- Why is 'V_{max}' not exceeded by any further rise in the substrate concentration?
- If a chemical substance closely resembling to that of a substrate is introduced into a reaction

system, what will be the consequences?

Sustantiate

16. Fill in the blanks coloumns with the correct terms/sentenc (HSE march-2009) (2)

A	B
.....(1).....	Catalyse oxiod reduction between 2 sustrate
Transferase(2).....
Lyases	Catalyse hydrolysis of ester, glycosidic bond
.....(3).....	Catalyse inter conversion of opical isomers
Ligase(4).....

Digestion and Absorption

- “The products of digestion like glucose and amino acids are absorbed to the blood by active transport, where as electrolytes like chloride ions are generally absorbed by simple diffusion.”
How will you differentiate active transport from simple diffusion ? (HSE-March 2020)(2)
- Enzymes present in Saliva, gastric juice and intestinal juice are given in the box.
(a) Identify the enzyme present in gastric juice and intestinal juice one each.
(b) Write their digestive function :

Pepsin, Lysozyme, Trypsinogen, Rennin, Lipases, Salivary amylase

- Observe the diagram of transverse section of human gut : (HSE-July-2019)(2)

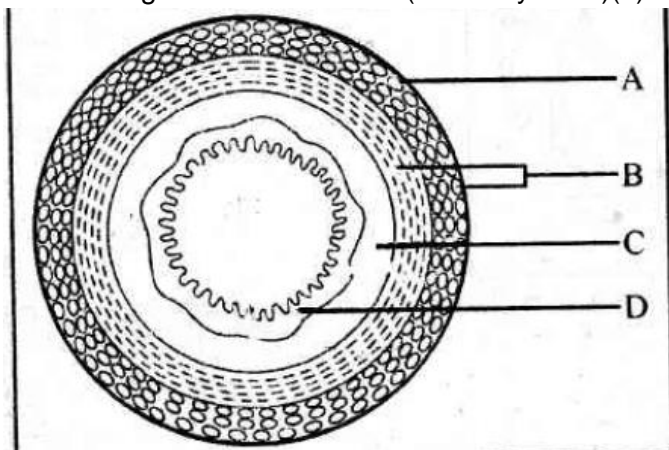

- Label A,B,C and D
 - Write any two structural modifications of mucosa at different parts of gut'
- a) Name the following : (HSE-March-2019)(2)

- The carbohydrate splitting enzyme present in human saliva.
- The anti bacterial enzyme present in human saliva.

- In which region of the alimentary canal does the following reaction occur?

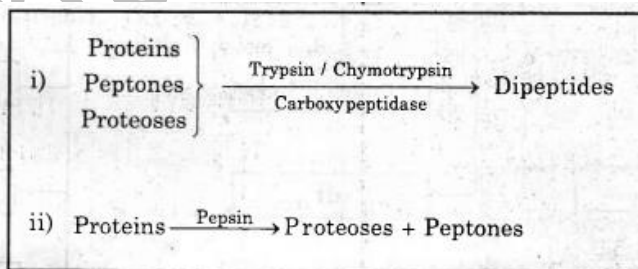

- The following diagram shows the action of protein digesting enzymes of Pancreas.

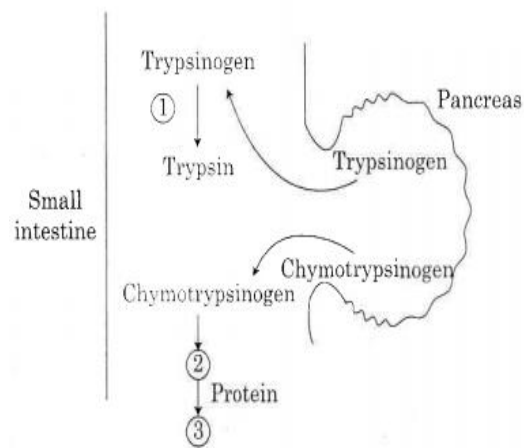

(HSE-Model-2019)(2)

- Label the number 1, 2 and 3.
 - Endocrine part of pancreas is known as
- Give one word for the following.
 - Presence of 2 sets of teeth in the life time.
 - Teeth are present in socket of Jaw bone.

(HSE-Aug-2018)(2)
 - Name the following : (HSE-March-2018)(2)
 - The antibacterial enzyme present in the saliva of man which helps in prevention of infection.
 - The digestive enzyme present in saliva.
 - Protein digestion by proteolytic enzymes is given below (HSE-March-2018)(3)

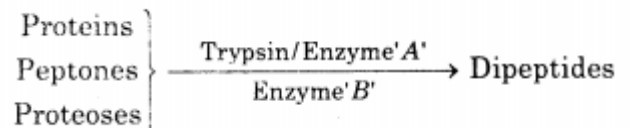

- Name the enzymes marked as A and B
 - Identify the gland which , secrete these enzymes.
 - Write the inactive form of the enzymes A and B
- Certain indicators regarding the layers in the wall of alimentary canal are given. Name the layer against the indicator
(HSE-Model-2018)(2)
 - Formed of loose connective tissue containing nerves and blood vessels
 - Inner most lining forms the rugae in the stomach
 - Formed by smooth muscles
 - Outermost layer made up of mesothelium

10. Complete the following table which shows digestive glands and their enzymes in an adult man ? (HSE-July-2017)(2)

Digestive gland	Enzymes	Functions
Gastric glanda.....	Protein digestion
Salivary gland	Salivary amylaseb.....
.....c.....	Nuclease	Nucleic acid digestion
Pancreas	Lipasesd.....

11. A)Observe the diagram and label A and B (HSE-March-2017)(2)

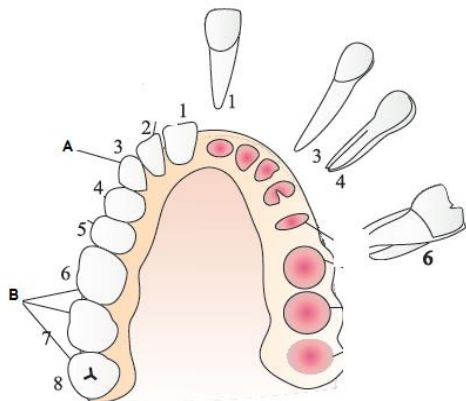

b)Dental formula of permanent teeth in man is.....

- i)2122/2122
- b)2123/2123
- c)2102/2102
- d)2122/2122

12. a)Observe the given diagram and identify the parts noted as A,B and C

b)write the role of secretion stored in part A (HSE-Sept-2016)(2)

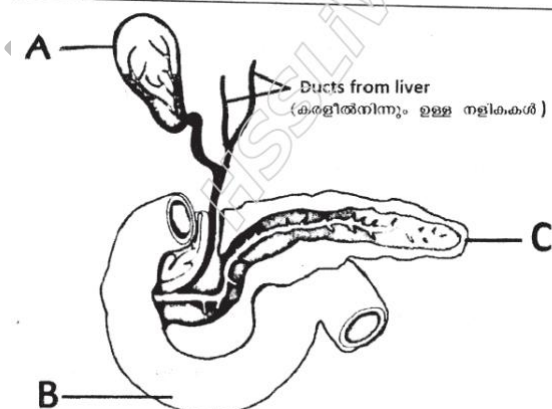

13. From the following list, pick out the enzyme, that takes part in carbohydrate digestion (HSE-march-2016) (1)

(Salivary amylase, peptidase, lipase, carboxy peptidase)

14. In human dentition is heterodont.this condition means.. (HSE-march-2016) (1)

- a)Presence of two types of teeth
- b)presence of two sets of teeth
- c)presence of different types of teeth
- d)teethes are palced in socket of jaw bone

15. Construct a flow chart to demonstrate the digestion of proteins in the different part of alimentary canal ? (HSE-September -2015)(2)

16. Observe the following diagram (HSE march-2015)(2)

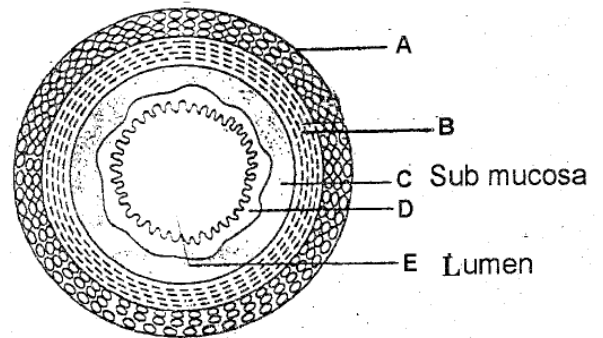

a)Name the figure?

b)Label part A,B and D

17. Identify the odd one and write the common features of other items

(Caecum,colon,rectum,renin)

(HSE august-2014)(1)

18. Proenzyme pepsinogen is a protein digesting enzyme (Inactive form) of the human digestive system

a)Name the digestive gland which secrete this enzyme?

b)How does the pepsinogen change into its active form, pepsin?

c)Complete the following sentence

Pepsin converts protein into proteoses and

(HSE august-2014)(2)

19. Sketch an outline (or a flow chart) of protein digesting taking place in your alimentary canal ? (HSE march-2014)(3)

20. Read the features of cell layers in the wall of human intestine (HSE,september-2013)(2)

- It consist of circular and longitudinal smooth muscle
 - Outer thin layer is formed of mesothelium
 - A layer formed of loose connective tissue and nerves
 - Epithelium with goblet cells to secrete mucus
- Identify the cell layers and arrange them from inside to outside as seen in the section of intestine

21. Bile contain no digestive enzyme, so bile is not needed for digestion . Do you agree with this statement?Justify your answer ?

(HSE-september 2012)(2)

22. Observe the given diagram and answer the following question? (HSE-march-2012)(2)

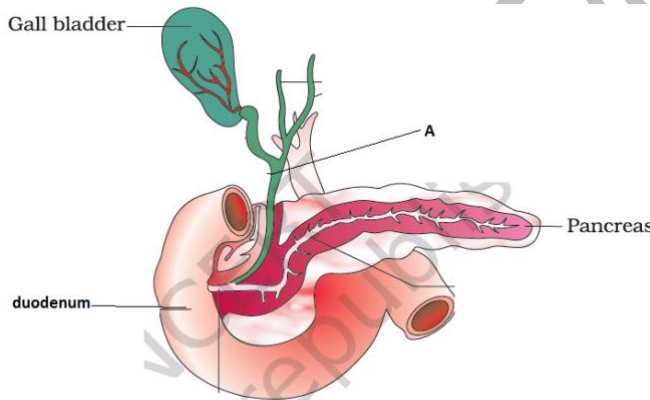

a)Identify the duct laelled A and the secretion it pours into the duodenum

b)Mention any two function of secretion in digestion?

23. "The end product of fat digestion are not absorded directly into blood stream". Justify (HSE-MARCH-2011)(2)

24. Observe the diagram (HSE-MARCH-2010)(2)

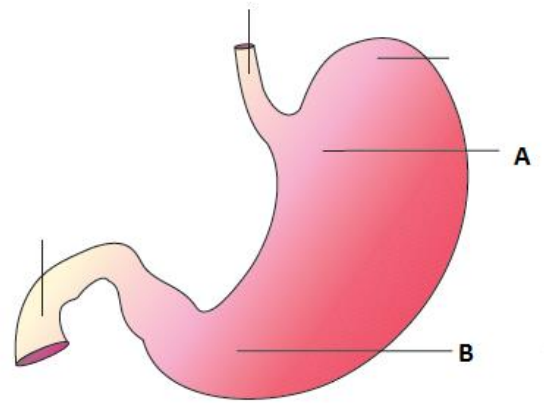

a)Label the parts A and B

b)Even though concetrated HCl is stored in the stomach, It willnot generally damage the stomach wall why?

25. The following reactions are catalysed by the enzymes produced from the digestive gland . Rewrite the reaction and write the correct enzyme above the arrow mark

(HSE march-2009)(2)

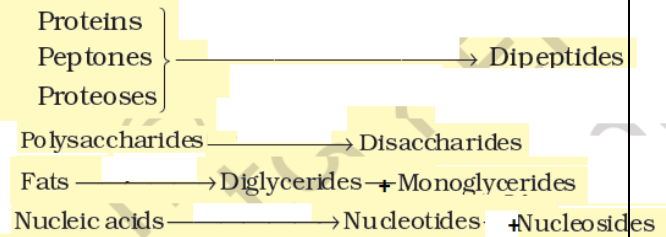

BREATHING AND EXCHANGE OF GAS

1. Select the enzyme that facilitate the following reaction : (HSE March 2020)(1)

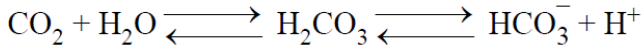

- (a) Succinic dehydrogenase (b) RuBiSCO
- (c) Carbonic anhydrase (d) Lipase

2. Distinguish between the following terms :

- (a) IRV, ERV (HSE March 2020)(2)
- (b) Tidal volume, Residual volume

3. List the major factors affecting the dissociation of oxygen from oxyhaemoglobin in the tissues?

(HSE-July-2019)(2)

4. Distinguish between : (HSE-March-2019)(2)

a)	Tidal volume and Residual volume
b)	Vital capacity and Total lung capacity

5. Analyze the concept map given below and if have mistake, reconstruct it

(HSE-Model-2019)(2)

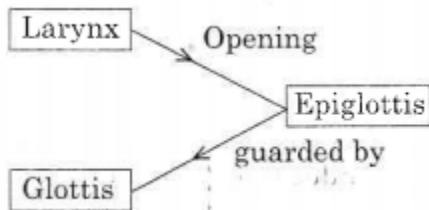

6. a) Identify the graph given below

(HSE-Aug-2018)(2)

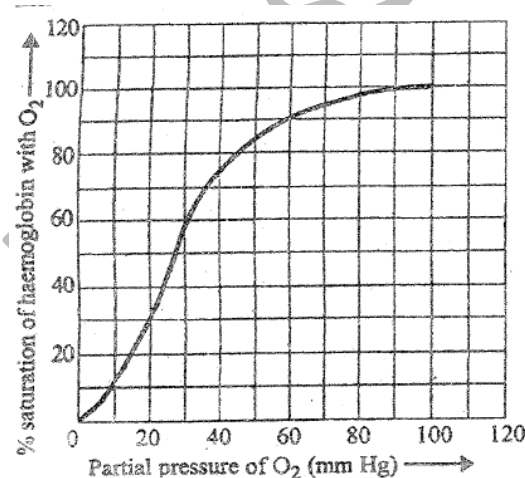

b) List the factors responsible for the formation and dissociation of oxyhaemoglobin

7. Distinguish between following :

- a) IRV and ERV b) IC and EC (HSE-March-2018)(2)

8. "In the tissues, the conditions are favorable for dissociation of oxygen from the oxyhaemoglobin " Write any four favourable conditions in the tissues for the dissociation of O2 from oxyhaemoglobin (HSE-Model-2018)(2)

9. In the given graph of oxygen, Haemoglobin dissociation curve 'X' axis denote partial pressure of oxygen. What does 'Y ' axis indicate ? write any 2 factors which affect the sigmoid curve ? (HSE-July-2017)(2)

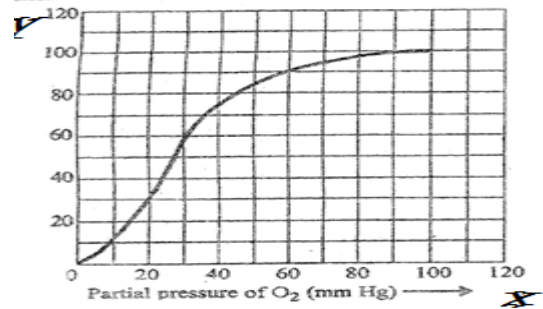

10. Differentiate the process of inspiration and expiration. (HSE-March-2017)(2)

Inspiration	Expiration
.....
.....

11. Diagrammatic representation of CO2 in man is given. Observe and answer the following ?

(HSE-Sept-2016)(2)

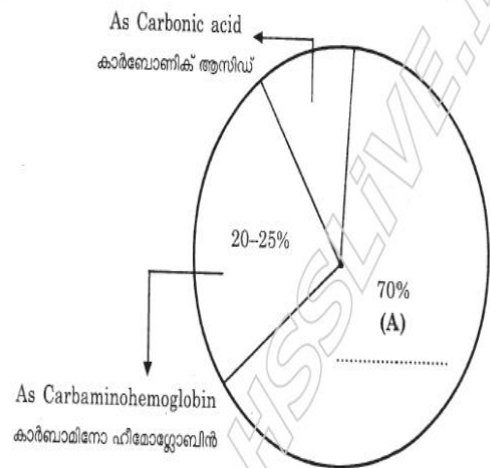

a) Name the method of CO2 transport indicated as A

b) Write the name of enzyme involved in the process A

12. CO₂ Transport in the form of bicarbonate ion is picturized below. Observe the diagram and identify the enzyme noted as "A"
(HSE-MARCH-2016)(1)

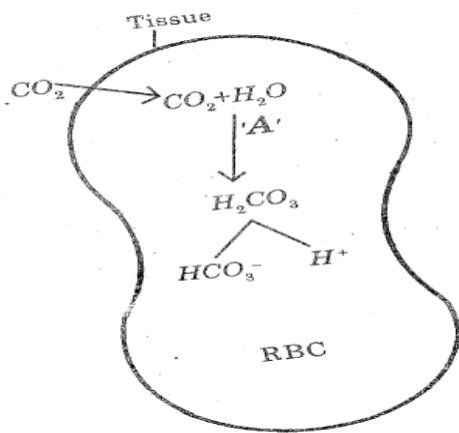

13. Carefully observe the given sigmoid curve on the graph and answer the following questions
(HSE-MARCH-2016)(2)

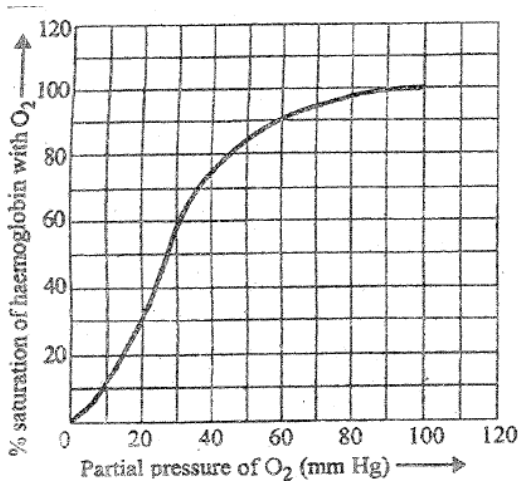

- a)What does the graph indicates?
b)What are the 3 factors affecting the sigmoid patterns of the graph?
14. Correct the following misconception of a student regarding the human respiration
(HSE-Septemer-2015)(2)
- Vital capacity include, tidal volume residual volume and dead air
 - Respiration is controlled by nerve centres located in the hypothalamus and cerebrum
15. Asthma and emphysema are two disorders of human respiratory system, mention their causes and symptoms? (HSE-March-2015)(2)
- 16.

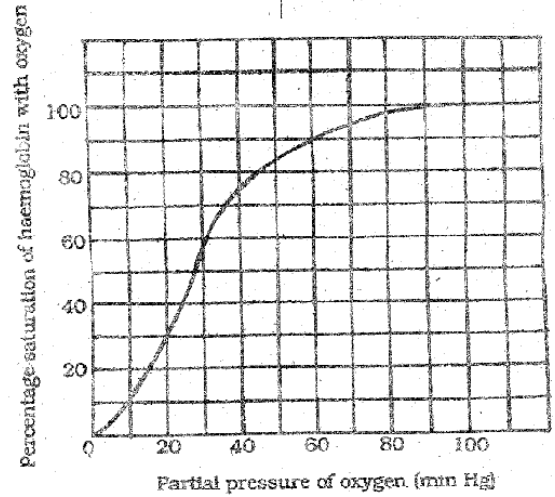

- a)What is presented by the above graph?
b)Write any three factors which can influence the sigmoid curve of this graph?
(HSE-august-2014)(2)
17. Blood transports CO₂ from tissues to lungs by avrious means.Mention any two methods of the same
(HSE-MARCH-2014)(2)
18. Observe the diagram and answer the follloing question (HSE-September-2013)(2)

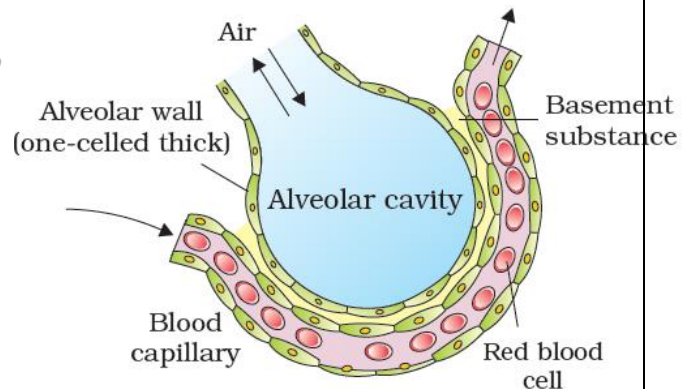

- a)Name the biological process involved in the gas exchange shown in the figure?
b)How the oxygen is transported to the cells from the alveoli?
19. Pick out the wrong one and justify your selection
(HSE march-2013)(2)
- VC=ERV+IRV+TV
 - TLC=VC+RV
 - TV=500ml
 - ERV=3000ml
20. Prepare an equation for a chemical reaction suing the ollowing components

NAVAS CHEEMADAN

Carbonic anhydrase, carbonic acid, water, carbon dioxide (HSE september-2012)(1)

21. Observe the Figure and answer the question (HSE september-2012)(2)

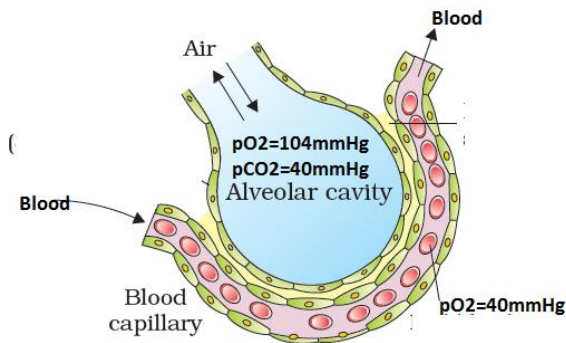

- What is the partial pressure of Oxygen in the alveolar capillary?
- Name the biological principles involved in the exchange of gases in the above structure?
- What happens when the partial pressure of oxygen becomes the same in the alveoli and the alveolar capillary?

22. Identify the two true statements from the statements given below and rewrite the two false statements correctly

(HSE march-2012)(2)

- Pneumonia is a chronic disorder due to cigarette smoking
- CO_2 combines with Hb to form carbamino haemoglobin
- Respiratory rhythm is maintained by the respiratory center in the heart
- Alveoli are the primary sites of exchange of gases

23. Observe the graph (HSE-march-2011)(2)

- Identify the pO_2 where 50% saturation of Hb with oxygen
- Mention the factors favorable for the formation of oxyhaemoglobin in alveoli

SOHSS-AREEKODE

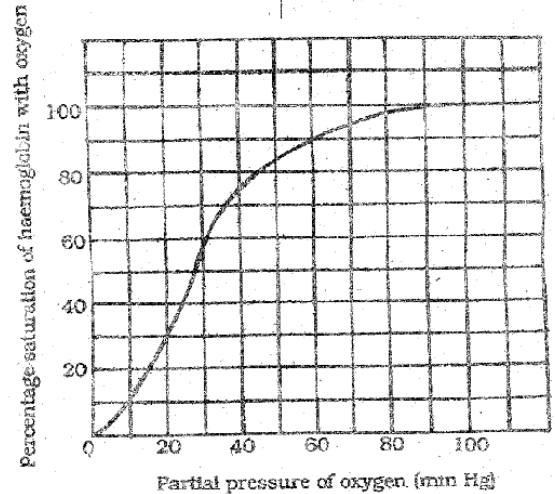

24. In a 400m race competition, Athira won the first place. Her friends commented that it is due to her vital capacity (HSE-March-2010)(2)

- What do you understand by the term vital capacity?
- Suggest the ways to improve the vital capacity?

25. Oxyhaemoglobin is formed when pO_2 is high. But oxyhaemoglobin dissociates when the pCO_2 is high, high H^+ concentration and high temperature.

Write what happens to oxyhaemoglobin in the alveoli and body tissues

(HSE-march 2009)(2)

BODY FLUIDS AND CIRCULATION

1. Observe the Diagram (HSE-March -2020)(3)

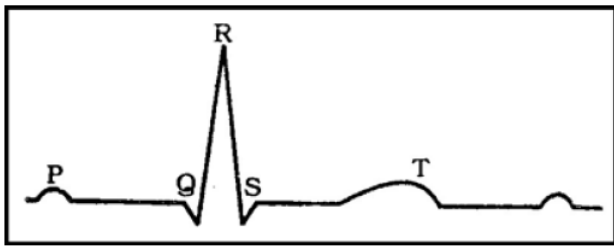

- (a) What does it denote ?
 - (b) What do P, QRS, T represent ?
 - (c) What is its clinical significance ?
2. (a) Make a flowchart showing cardiac impulse conduction using appropriate terms given in bracket. (HSE-July-2019)(2)
- [SAN, Right atrium, AVN, AV Bundle, Bundle of His, Ventricle]**
- (b) Which part known as pacemaker ?
3. Blood coagulation, is a mechanism to prevent the excessive loss of blood. (HSE-July-2019)(3)
- (a) Identify the enzyme help the conversion of inactive fibrinogen.
 - (b) Mention the role of thrombokinase.
 - (c) Which ion is necessary for blood clotting ?
4. Diagrammatic representation of a standard ECG is given below. (HSE-March-2019)(3)

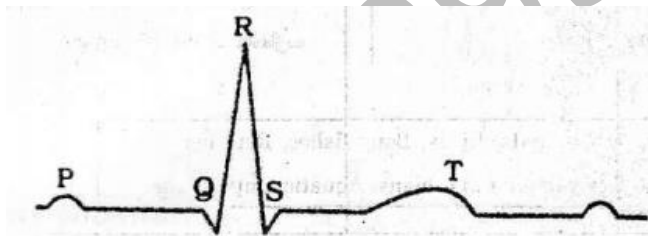

- a) Expand ECG
 - b) What does 'P', 'T' waves denote?
 - c) Mention the clinical significance of ECG ?
5. a) Person with 'AB' blood group is called 'universal recipient'. Give a reason"
- b) List out any two disorders of human circulatory system. (HSE-March-2019)(2)
6. Copy the table and fill in the gap with appropriate words. (HSE-Model-2019)(3)

Blood Cell	Type of Cell	Classification	Function
?	Granulocyte	?	Phagocytosis
		Basophil	?
		Lymphocyte	?
		Monocyte	?

(HSE-Model 2019)(3)

7.

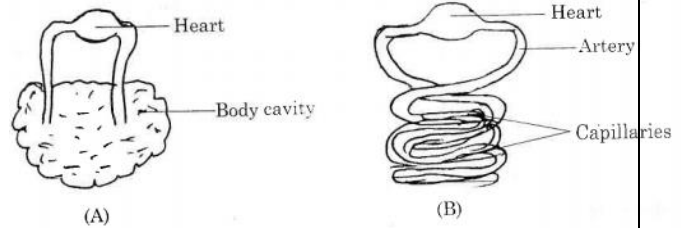

- a. Name the above two diagram A and B.
 - b. Write one example for each in which they belongs.
 - c. The blood filled blood filled cavity- of cockroach is known as
8. Plasma without clotting factor is called..... (HSE Aug-2018)(1)
9. Classify the following terms under two suitable headings. (HSE Aug-2018)(2)

Neutrophil, Monocyte, Eosinophil, Lymphocyte

10. diagrammatic representation of a standard ECG is given below : (HSE-March- 2018)(2)

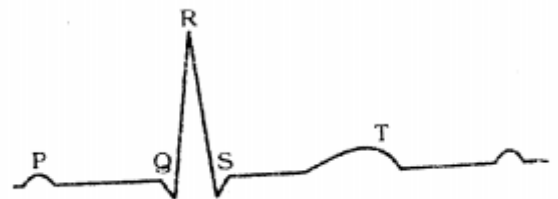

- a) What does the QRS complex denotes?
 - b) Mention the clinic al significance of ECG.
11. Match the terms in column A with those in columns B and C (HSE-March- 2018)(3)

	A	B	C
a)	Neutrophils	2 - 3%	Immune response
b)	Eosinophils	20 - 25%	Phagocytic
c)	Lymphocytes	60 - 65%	Allergic reaction

12. Fill in the lanks suitably (HSE-Model-2018)(3)

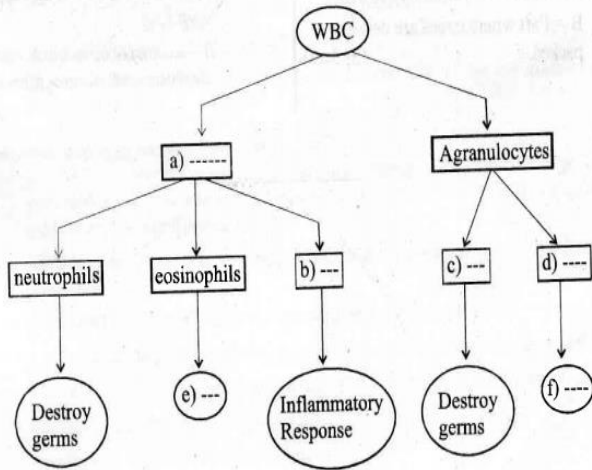

13. SA node has the key role in the rhythmic activity of human heart. Give reason ?

(HSE-July-2017)(2)

14. In the medical record of a patient blood pressure is notes as 140/90mm Hg. What does it indicate ?

(HSE-July-2017)(1)

15. a) Select the correct statement regarding with ECG of man

(HSE-March-2017)(1)

- i) P-wave represent auricular repolarisation
- ii) P- Wvae represent ventricular repolarisation
- iii) P- wave represent auricular depolarisation
- iv) P-wave represent ventricular depolairisation

b) Observe the diagram and label A,B,C and D (2)

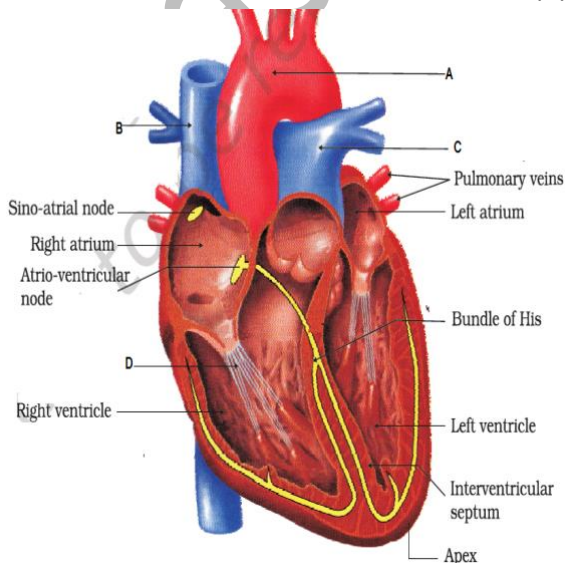

16. a) Fill Up A,B,C, D and complete the branching chart given below (HSE-Sept-2016)(3)

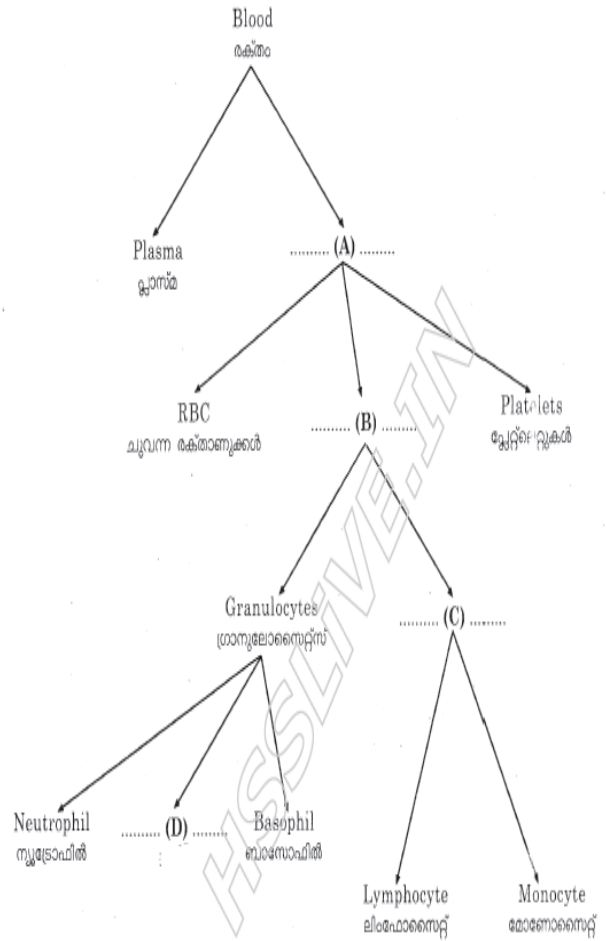

b) Write the function of palletelets ?

OR

In man normal ECG consist of 3 waves

a) P wave b) QRS wave c) T wave

what does the above wave means ?

(HSE-SEPT-2016)(3)

17. Longitudinal section of the human heart showing internal structure is given below. Oserve the diagram and answer the following question. (HSE-MARCH-2016)(3)

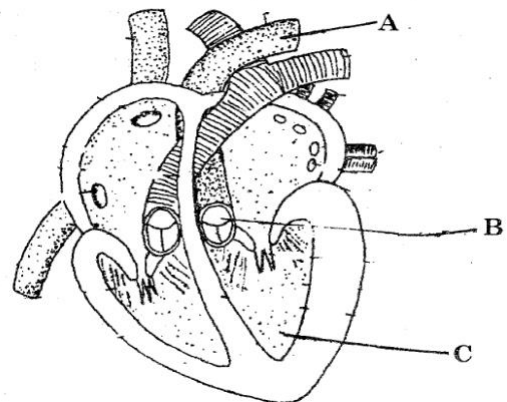

NAVAS CHEEMADAN

- a) Label the parts marked as A, B and C?
- b) Draw a flow chart showing double circulation?

OR

18. "Sinu atrial node is called pacemaker of human heart"
 - a) justify the statement?
 - b) define cardiac cycle and cardiac output?
19. In a laboratory session your biology teacher exhibited blood smear (slide) of cockroach and human being under microscope. How will you distinguish them based on the nature of plasma and blood cells? (HSE-SEPT-2015)(2)
20. Make a diagrammatic sketch of human double circulation. Label the 3 associated organ and any one blood vessel (HSE-SEPT-2015)(3)

OR

21. Name the two types of heart valves and mention their function? (HSE-SEPT-2015)(3)
22. Find the odd one and write the function
Neutrophil, erythrocyte, monocyte, lymphocyte, basophil, eosinophil (HSE-MARCH-2015)(1)
23. Observe the flow chart and answer the questions given below

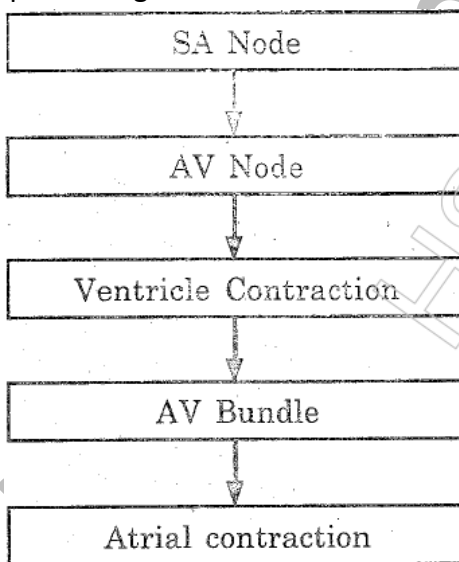

- a) Draw the flow chart correctly?
 - b) what will happen if the SA node is not working properly? (HSE-MARCH-2015)(2)
24. The sequential events in the heart which are cyclically repeated are called cardiac cycle (HSE-AUGUST-2014)(3)
 - a) What are the phases of cardiac cycle?

navas9895@gmail.com

SOHSS-AREEKODE

- b) why do we call the human heart as myogenic?
 - c) what is the role of SAN (Sinu Atrial Node) on a human heart?
25. Answer the following in a few words
 - a) significance of pulmonary circulation in man?
 - b) functions of erythrocytes
 - c) pacemaker for a human heart and its significance?
 - d) Normal blood pressure of a human being and its variation during hypertension (HSE-MARCH-2014)(4)
 26. Observe the blood cells and attempt the following questions (HSE-2013-SEPT)(2)

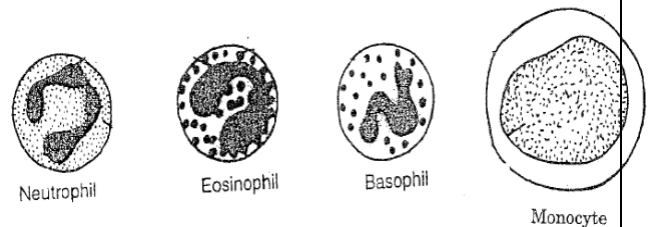

- a) which among the above cells least possibly found when you observe a drop of blood?
 - b) write one function of any two types
 - c) categorise the WBC based on the presence or absence of protein granules?
27. Due to developmental anomaly the wall of left ventricle of an infant's heart has the same thickness as that of right ventricle. What would be its specific effect on circulation of blood? (HSE-sept-2013)(1)
 28. A person with A-ve blood group is injured severely in an accident. His relatives with A+ve and B-ve blood group were ready to donate blood for him. Infer the consequence if he receive the blood from him? (HSE-march-2013)(1)
 29. Observe the ECG (HSE-March-2013)(2)

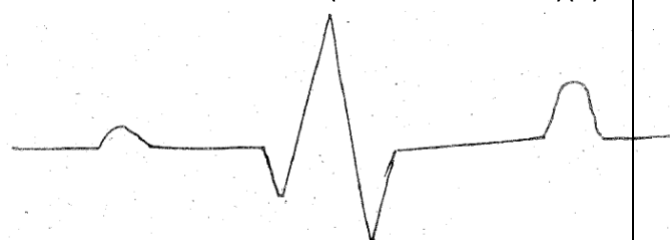

- a) Label P, Q, R, S, T in the graph

NAVAS CHEEMADAN

NAVAS CHEEMADAN

b) what does the T wave represent?

30. Is it possible to compare the water vascular system of phylum echinodermata to circulatory system of man in some aspects? Justify the statement? (HSE-sept-2012)(2)

31. The blood pressure of a person is shown as 170/130mmHg. What would be his disease? How it affect his body? (HSE-sept-2012)(1)

32. Observe the figure and answer the question (HSE-Sept-2012)(2)

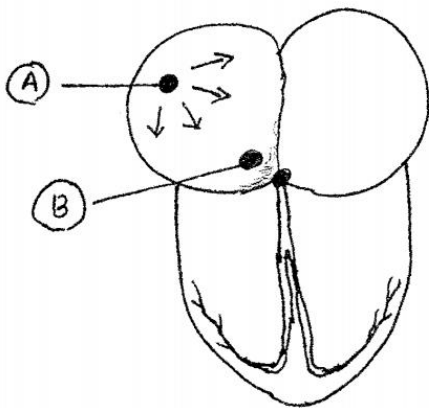

a) Name the nodal tissue A and B

b) Why A is called pace maker

33. If a person having blood group A is given blood transfusion of blood group B by mistake. What will be its effect? (HSE-march-2012)(1)

34. Stethoscope is an instrument which is used to detect the sounds of the heart.

a) Mention the two sound of the heart?

b) Give the cause of heart sound?

(HSE-march-2012)(2)

35. Result of a project study related to a circulatory disorder to an area is given below (HSE-march-2011) (3)

a) What is your observation?

b) Name any one circulatory disorder and its characteristics?

c) Suggest any two measures to avoid these disorders?

36. The blood test report of a patient is given below (HSE-MARCH-2010)

- RBC 5.5million/mm³
- Neutrophil 65%

SOHSS-AREEKODE

- Monocyte 5%
- Basophil 1%
- Eosinophil 15%
- Lymphocyte 23%
- Platelets 250000/mm³

a) Which constituent of his blood is abnormal?

b) What is the normal function of that constituent?

37. Observe the flow chart and answer the question given below

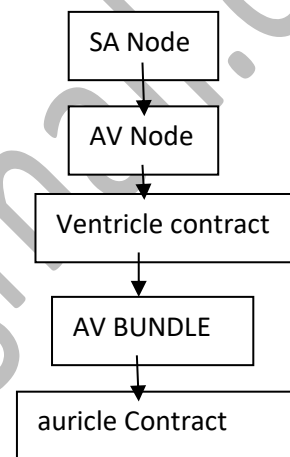

a) Re draw the flow chart correctly?

b) What will happen if the SA node is not working properly?

EXCRETORY PRODUCTS AND THEIR ELIMINATION

- Find out the suitable term from the box for the disorders stated. (HSE-March-2020)(2)
 - Accumulation of Urea in blood.
 - Insoluble mass of crystallised salts in the kidney.
 - Surgical method for the correction of Renal failures.
 - Inflammation of glomeruli of kidney.
- Complete the flow chart showing the regulation of kidney functioning by Juxta Glomerular Apparatus and Adrenal Cortex.

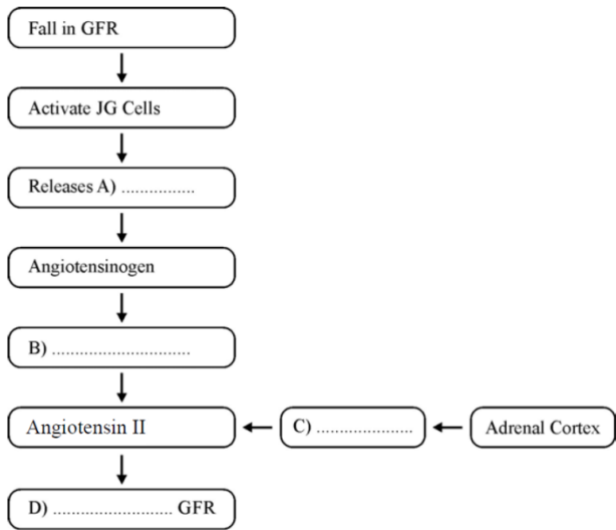

(HSE-March-2020)(2)

- Classify the following animals on the basis of the mode of nitrogenous waste excretion in the table given below (HSE-March-2019)(2)

Mammals, Birds, Bony fishes, Reptiles,
Terrestrial amphibians, Aquatic amphibians

Ammonotelic	Ureotelic	Uricotelic

- Give one word for the following:

- Presence of Glucose in Urine
 - Presence of Ketone bodies in Urine

b) Which human disorder is having the above mentioned two symptoms? (HSE-March-2019)(2)

- Complete the following sentences.
 - Reabsorption of water from DCT is facilitated by the hormone.....

- Kidney failure can cause a bone disorder called.....
 - Angiotensin II activate adrenal cortex to release.....
 - In case of kidney failure urea can e removed y the process called
- (HSE-Model-2019)(2)

- Some conditions related to kidney disease are given
 - Accumulation of urea in blood.
 - malfunction of kidney
 - Name the condition.
 - In your opinion, suggest the treatments for kidney failure and acute kidney failure ?

(HSE-Aug-2018)(2)

- Expand GFR
 - Even though GFR in a healthy person is 180 liters per day, the amount of urine released Per day is only about 1.5 litres. Give a reason.

(HSE-March 2018)(2)

- Write the significance of reabsorption in urine formation' (HSE-Model-2018)(2)
 - Of the following substances which one is reabsorbed by active transport ?
Glucose, Nitrogenous waste, Water

- Fish : amnonotelic :: Cockroach:.....
(HSE-Model-2018)(1/2)

- “The functioning of the kidneys is efficiently monitored and regulated by the heart to certain extent”
Do you agree with this statement
Justify your answer ? (HSE-Model-2018)(2)

- Observe the given diagram of malpighian body (Renal corpuscle)and answer the following

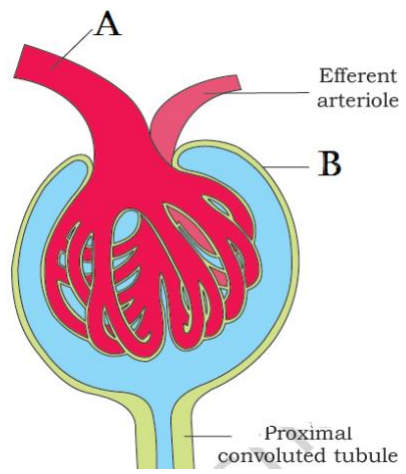

- Identify the parts A and B.
 - Specify the functions of Proximal convoluted tubule in urine formation?
- (HSE-July-2017)(2)

12. Prepare 2 matching pairs from the given list of animals and excretory organs
(HSE-March 2017)(2)

Animals	Excretory organs
a)Prawn	i)Nephredia
b)Cockroach	ii)Antennal gland
c)Earthworm	iii)Flame cell
	iv)Kidneys

13. Uricotelism is more advantageous than ureotelism and ammonotelism in strictly terrestrial animals on the basis of water conservation in their body. Justify?
(HSE-SEPT-2016)(2)

14. The functioning of human kidney is efficiently monitored and regulated by hormonal action of hypothalamus, pituitary, JGA and to certain extent by heart

- a) Do you agree with this statement?
b) Justify your answer with suitable reason?

(HSE-MARCH-2016)(2)

15. Terrestrial animals are either Ureotelic or Uricotelic not ammonotelic. Evaluate the statement?
(HSE-SEPT-2015)(2)

16. Observe the figure given below and answer the question
(HSE-MARCH-2015) (2)

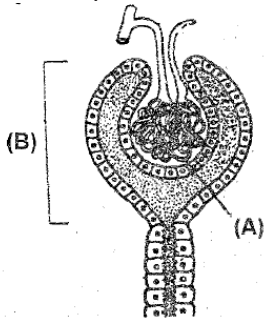

- a) Write the name of the figure?
b) Name the labeled part A and B?
c) Which is the site of formation of ultra filtrate?

17. A diagrammatic representation of nephrons is given below

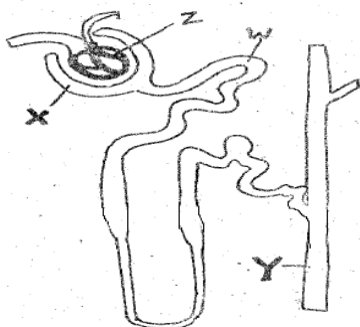

- a) Identify the part labeled as X and Y
b) Which part/parts of a nephron constitute Malpighian body?
(HSE-AUGUST-2014)(2)

18. The output of urine increases in cold days while decreased in hot and sunny days. Can you give the reason for this phenomenon as realized from the graph given below?

(HSE-MARCH-2014)(2)

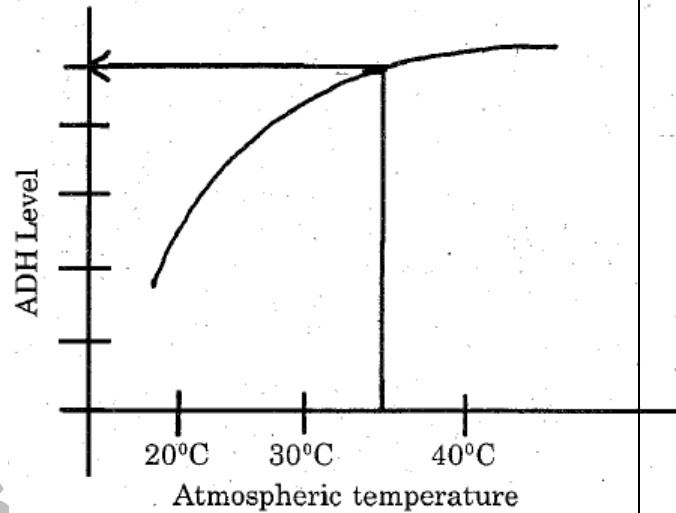

19. Observe the schematic diagram showing the mechanism for regulating blood volume.

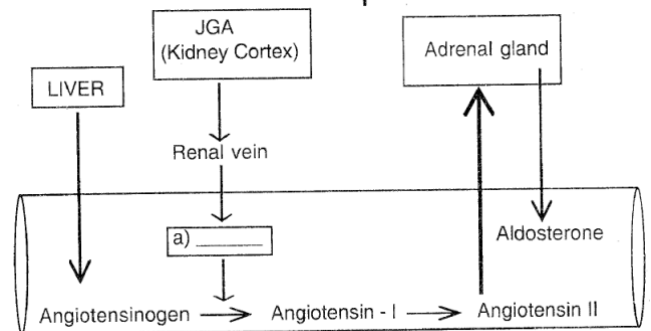

- a) Fill the gap in the diagram?
b) Illustrate how blood volume is regulated by this system?
(HSE-SEPT-2013)(2)

20. In a biology class related to excretion in the human body, a student gave an opinion that in every minute about 2% of total blood volume is converted into GFR whereas only 1% of GFR is eliminated as urine. Evaluate this opinion and substantiate your answer?
(HSE-March-2012)(2)

21. How the counter current mechanism helps to maintain concentration gradient in medullary interstitium?

OR

- On a hot day would you expect your level of ADH in blood to be high or low? Explain?

(HSE-sept-2012)(2)

navas9895@gmail.com

Locomotion And movement

1. Name the portion of the myofibril between two successive Z-lines. (HSE-March-2020)(1)
(a) H-zone (b) Sarcomere
(c) I-band (d) M-line

2. Cells of human body perform different types of movement. Write any two types of movement and the parts that exhibit the movement

Dialysis, Kidney transplantation, Glomerulonephritis, Uremia, Renal Calculi

(HSE-March-2020)(2)

3. Name-of the bones of appendicular skeleton are given below (HSE-July-2019)(2)

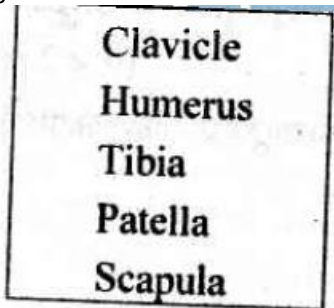

- (a) Select the bones of pectoral girdle.
(b) Name the articulating cavity between femur and pelvic girdle

4. Major steps involved in muscle contraction are given below, which are not in the correct order. Arrange them in the correct order.

- (a) Remove the mask of active sites for binding myosin
(b) A signal sent out by CNS
(c) Binding of Ca⁺ with troponin
(d) Release of a neuro-transmitter substance
(e) Release of Ca⁺ into the sarcoplasm

(HSE-July-2019)(2)

5. Observe the figures given below

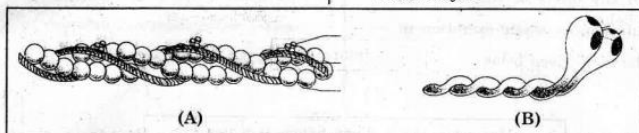

- a) Identify figure 'A' and 'B'.
b) Name the subunits of 'A' and 'B'.

(HSE-March-2019)(2)

6. Complete the division of human skeletal system by- filling the blanks (HSE-Model-2019)(2)

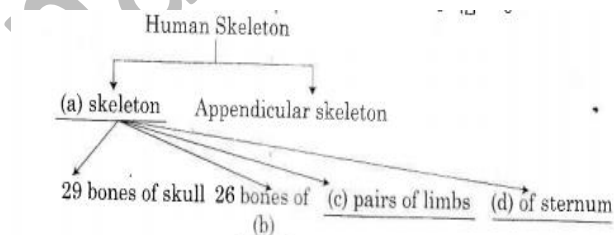

7. Identify the disorders based on the symptoms given below. (HSE-Aug-2018)(2)

- a) Inflammation of joints.
b) Decreased bone mass and increased chance of fracture.

- c) Inflammation of joints due to the accumulation of uric acid crystals
d) Rapid spasms in muscles due to low Ca⁺⁺ in body fluids.

8. Select the WRONG statement regarding muscles from those given below and correct it.

- a) Each muscle fibre is lined by the plasma membrane called sarcolemma.
b) The light bands are called 'A' band or Anisotropic band
c) The Portion of the myofibril between two successive 'Z' lines is called a sarcomere
d) Muscle contains a red coloured oxygen storing Pigment is called' myoglobin

(HSE-Aug-2018)(2)

9. Select the bones of the leg from the given list of bones. (HSE-March-2018)(2)

Humerus, Tibia, Radius, Femur, Tarsals, Ulna, Fibula, Carpels

10. How does the increased level of calcium ion in the sarcoplasm help in muscle contraction

(HSE-Model-2018)(2)

11. Certain disorders and their causes are given. Match them suitably (HSE-Model-2018)(2)

<ul style="list-style-type: none"> • Myasthenia gravis • Tetany • Muscular dystrophy 	<ul style="list-style-type: none"> • Inflammation of Joints • Auto Immune disorder • Low Calcium ions in body fluid • Genetic disorder
---	--

12. An athlete met an accident on the ground. His thigh bone slipped off from the girdle.

- a) Write the name of the above mentioned girdle ?

- b) Identify the type of joint that slipped off?
c) Name the disorder caused due to the accumulation of uric acid crystals in such a joint? (HSE-July-2017)(2)

13. Complete the following chart showing structure of myosin filament and its protein based on the hints given in the brackets.

(HSE-March-2017)(2)

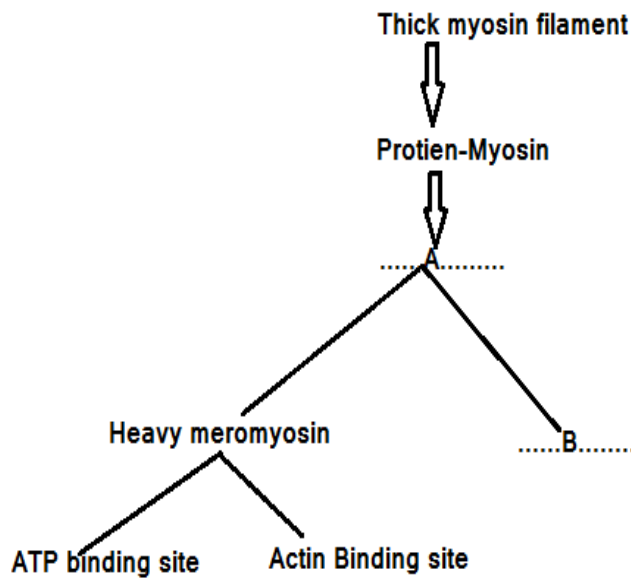

14. Name of few bones of appendicular skeleton is given below

- Clavicle
- Humerus
- Tibia
- Patella
- Scapula

a) select the bone of pectoral girdle?
 b) Name the articulating cavity between femur (Thigh bone) and pelvic girdle?

(HSE-sept-2016)(2)

15. "A contracted muscle become shorter and thicker but its volume remains the same"

a) Which theory explains the process of muscle contraction?
 b) Identify two contractile protein present in the muscle ?

(HSE-march-2016)(2)

16. Based on the diagram given below, can you write down the structural changes occurring in sarcomere during muscular contraction (Hint : Any two changes)

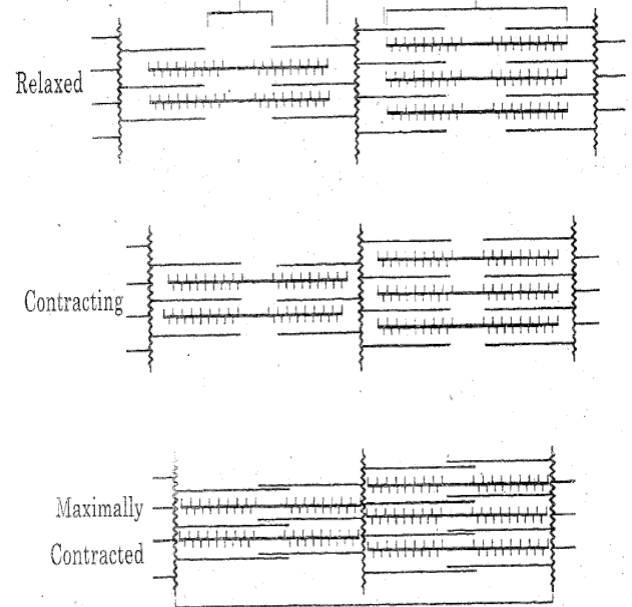

Two Sarcomeres

(HSE-Sept-2015)(2)

17. Red muscle fibre has greater capacity to do work for a prolonged period, where as white muscle fibre suffers from fatigue after a short work. Evaluate this statement?

(HSE-March-2015)(2)

18. The important finding in the case sheet of Two patients A and B show that both are suffering from the disorder of the skeletal system

a) Patient A is suffering from inflammation of the joint due to accumulation of uric acid crystal
 b) Patient B shows decreased bone mass and decreased level of oestrogen

Identify the disorder Or Diseases of A and B?

(HSE-August -2014)(2)

19. Give two examples for each of the following

a) synovial joints
 b) muscular proteins

(HSE-march-2014)(2)

20. In your zoology practical class, teacher brought a tray containing the following human bones Humerus, patella, carpals, ulna, radius, tibia, tarsal, femur

a) Categorize them into two?
 b) Give the criteria for your categorization

(HSE-September-2013)(2)

21. Observe the structural representation of the muscles given below :

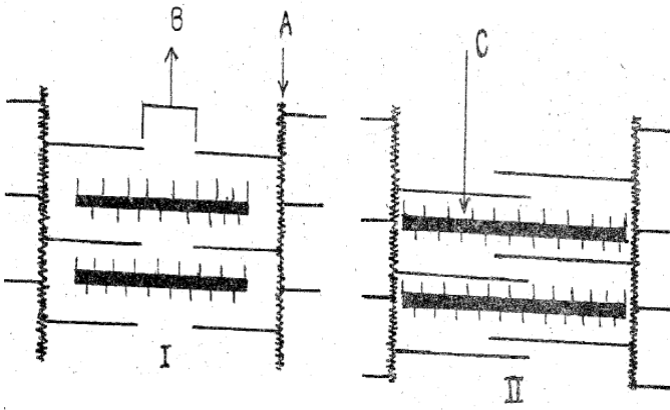

a) Which among these represent contracted state?

b) Name the part labeled as A, B, and C
(HSE-March-2013)(2)

22. Draw a flow chart showing physiological processes involved in the formation of cross bridge during muscle contraction ?

(HSE-Sept-2012)(2)

Neural control And coordination

1. Observe the diagram (HSE-March 2020)(3)

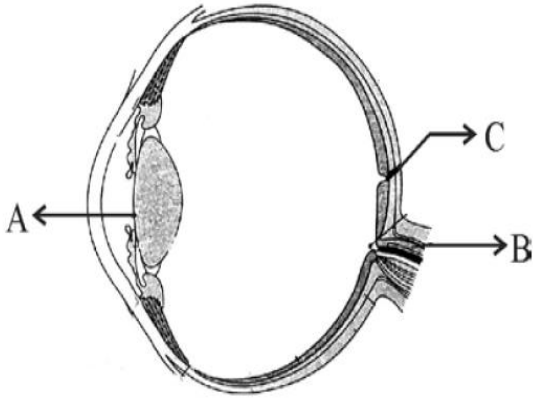

- (a) Name the parts A & B.
- (b) Write the characteristics features of 'C'.
- (c) Arrange the given parts of eye in the sequence that light travels from the external environment into the eye.

(Vitreous chamber, lens, cornea, retina, Aqueous chamber)

- 2. Which of the part of brain control respiration and gastric secretions? (HSE-July-2019)(1)
 - (a) Cerebrum (b) Cerebellum
 - (c) Medulla (d) Hypothalamus
- 3. Distinguish between the following :
 - (a) Electric synapse and Chemical synapse
 - (b) Rods and cone (HSE-July-2019)(2)
- 4. Prepare a flow chart showing the parts of human brain, by using the details given below (HSE-July-2019)(3)

Cerebrum, Medulla, Mid brain, Thalamus, Pons, Corpora quadrigemina, Hypothalamus, Forebrain, Cerebellum, Hypothalamus, Hind brain, Brain.

- 5. a) Identify the below stages of nerve impulse conduction. (HSE-Model-2019)(3)
- (b) Name the ions involved in this process.
- (c) How RMP is maintained

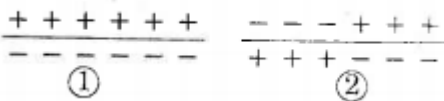

- 6. Complete the flow chart given below (HSE-Aug-2018)(3)

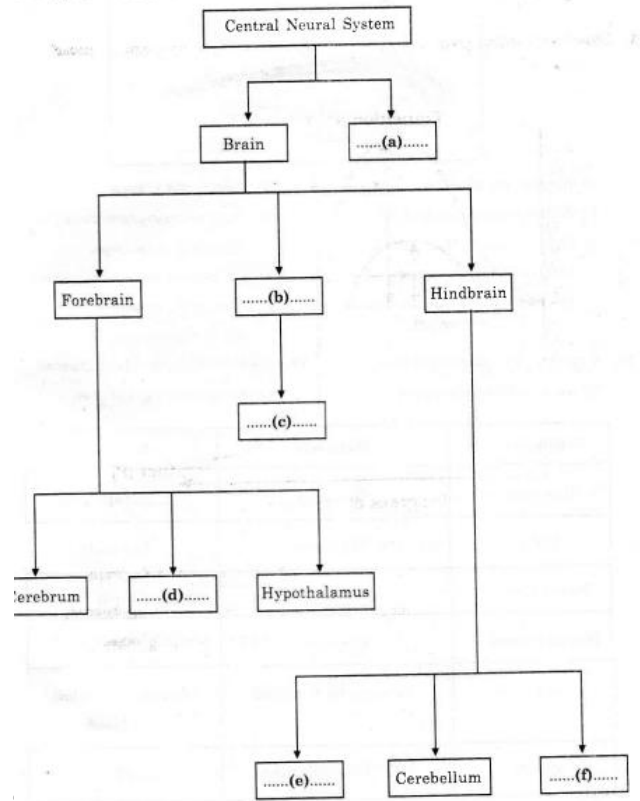

- 7. The innermost eyeball is (HSE-March 2018)(1)
 - a) Choroid b) Iris c) Retina d) Sclera
- 8. Complete the given flow chart (HSE-March-2018)(2)

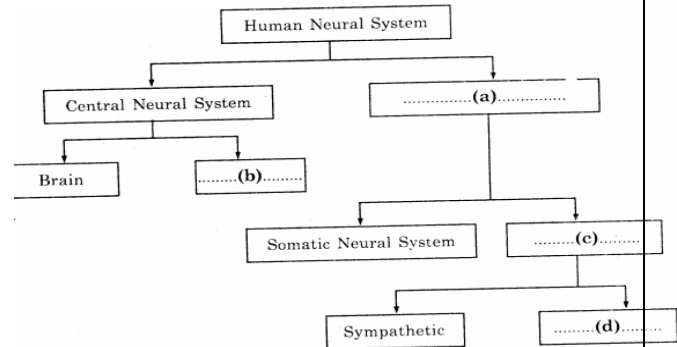

- 9. Redraw the diagram. Name and label the parts indicated below (HSE-Model-2018)(3)

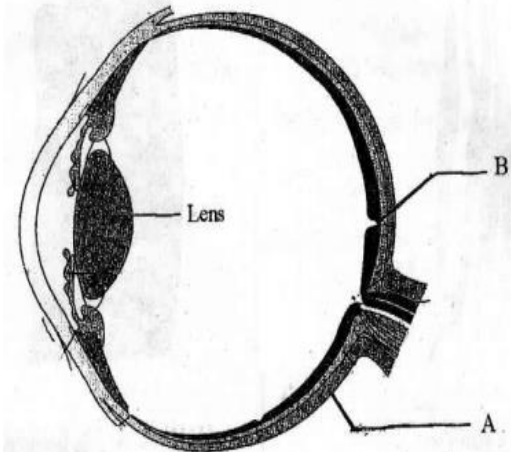

NAVAS CHEEMADAN

A - External layer of the eye ball.

B - Part where cones are densely packed.

10. In...(a) type of synapse the membranes of pre synaptic and post synaptic neurons are in very close proximity

In...(b)..type of synapse the membrane of pre synaptic and post synaptic neurons are separated by a fluid filled space

a)Name the type of synapse A and B

b)Name the fluid filled space in the synapse B
(HSE-Model-2018)(2)

11. Nerve impulse transmission includes generation and propagation of action potential.

Write various stages or events in the generation of action potential

(HSE-July-2017)(3)

OR

12. Observe the diagram and construct a flow chart to show the mechanism of transmission of nerve impulse across a chemical synapse

(HSE-July-2017)(3)

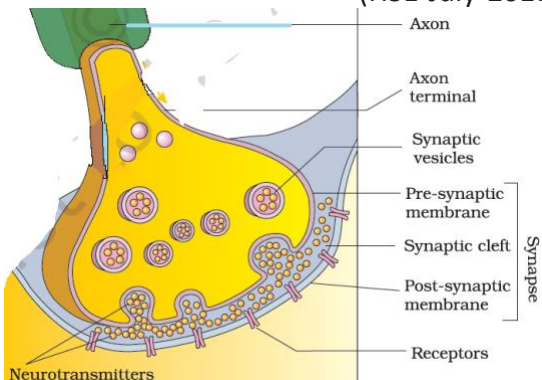

13. Answer the following (HSE-March-2017)(1)

a)Cerebral hemispheres of Human Brain are connected by.....

- i)Association area
- ii)Corpus callosum
- iii)Corpora quadrigemina
- iv)Pons varoli

b)Observe the diagram and Label A,B,C and D
(HSE-March-2017)(2)

SOHSS-AREEKODE

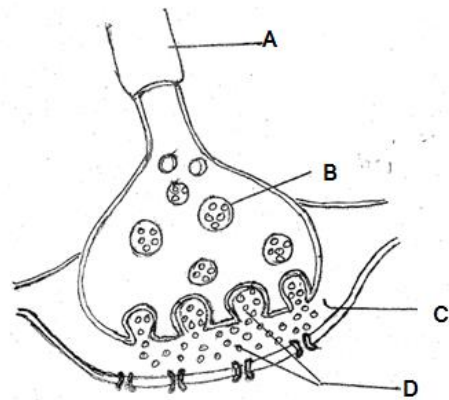

14. Fovea of Retina of eye contains.....

- a) Rod cells only
- b) Cone cells only
- c) Both Rods and cones
- d) Rods and cones are absent

(HSE-SEPT-2016)(1)

15. a)Complete the given table

(Parts of Human brain)(HSE-SEPT-2016)(2)

	Fore brain		Hind brain
	Parts/ഭാഗങ്ങൾ		Parts/ഭാഗങ്ങൾ
i)	Cerebrum/സെറിബ്രം	i)	Pons/പോണ്ടിസ്
ii)	Thalamus/തലാമസ്	ii)
iii)	iii)	Medulla/മെഡുല്ല

b) Which one of the above parts of brain that controls gastric secretion?

16. Observe the diagram carefully and answer the following
(HSE-March-2016)(3)

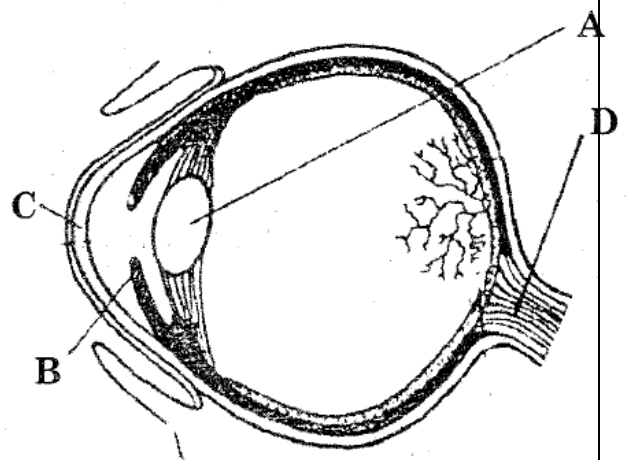

a) Label the parts marked as A,B,C,D?

b) Identify the photoreceptor cells present in the human eye?

17. Where do you find the following structure in Human body? (HSE-SEPT-2015)(1)
 a)Cochlea b)Neurotransmitter
18. Mention the function of the following structure in Human body? (HSE-SEPT-2015)(2)
 a) Hypothalamus b)axon
19. a)Prepare a pathway of an action by using the following hint (HSE-March-2015)(3)
(Hint : Receptor, motor neuron, afferent neuron, efferent neuron, inter neuron in the spinal cord, effector organ)
 b) Give an example of such an action

OR

20. Compare rods and cones of the retina based on the following features(HSE-March-2015)(3)
 i)Shape
 ii)Type
 iii)Ability to detect colour
 iv)Pigments
 v)Vision

21. (HSE-August-2014)(3)

Given below are the stages in the generation of optic nerve impulse or action potential on the retina and the role of opsin and retinal in the mechanism of vision. Arrange them in a sequential order.

- a) Action potential (impulses) are transmitted by the optic nerves to the visual cortex area of the brain.
- b) Light induces dissociation of retinal from opsin.
- c) Generates action potential in the ganglion cells through bipolar cells.

d) Structural changes in the opsin which induce membrane permeability changes.

e) Potential differences are generated in the photoreceptor cells.

f) Neural impulses are analyzed by visual cortex area of the brain.

22. Write the function of part-1 and 4. Label part 2 and 3 in the following figure showing synapse (No need to Copy the picture) (HSE-March-2014)(3)

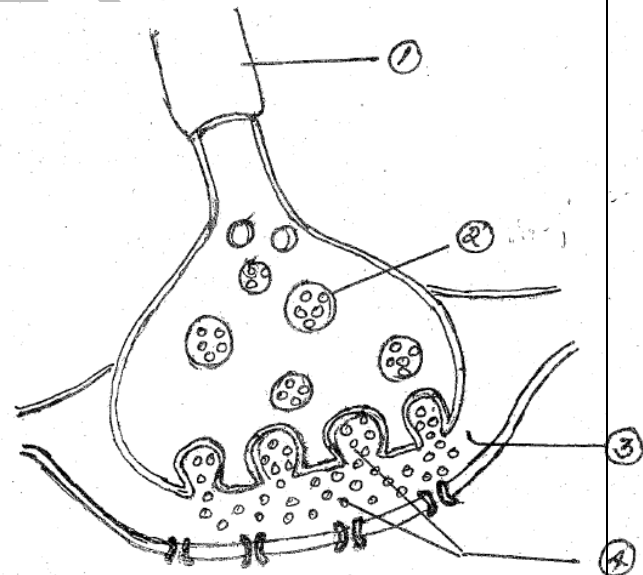

23. (HSE-Sept-2013)(3)
 Nerve impulse transmission involves.

- Maintenance of resting potential
 - Development of action potential
 - Propagation of action potential
- a) Diagrammatically represent the polarised and depolarised state of axon of a neuron.
- b) Describe how the resting potential of a neuron is maintained.
- c) "Electrical currents fade as they pass along a wire but nerve impulses do not fade as they pass along neurons". Evaluate the statement and substantiate your answer.

24. (HSE-March-2013)(3)

Arrange the following processes in nerve impulse conduction in a sequential order.

- a) Bursting of synaptic vesicle
- b) Development of action potential
- c) $Na^+ - K^+$ pump starts functioning
- d) Stimulus received and influx of Na^+ ions
- e) Binding of neurotransmitter with postsynaptic membrane
- f) Maintenance of resting potential

25. Analyze the concept map given below and fill the gap appropriately so as to explain the concept of human brain

(HSE-Sept-2012)(3)

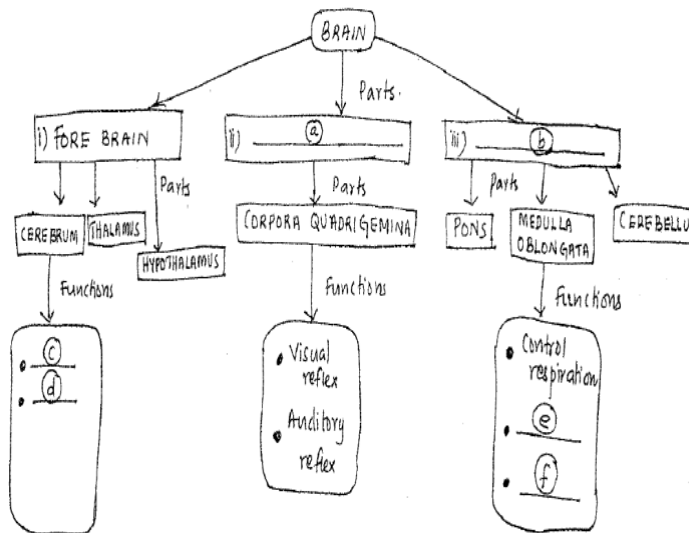

Chemical coordination And Integration

1. 'Adrenal medulla is the centrally located tissue in the adrenal gland, where as adrenal cortex is located outside.'

How do adrenal cortex and medulla differ in their function? (HSE-March-2020)(2)

2. Complete the given table appropriately.

Gland	Hormones	Function
(i) (A) _____	Androgens	Development of male accessory sex organs
(ii) Thymus	(B) _____	(C) _____
(iii) (D) _____	Glucagon	Maintains normal blood glucose levels
(iv) Pineal	(E) _____	(F) _____

(HSE-March 2020)(3)

3. Identify the picture and label the parts A, B, C, D.

(HSE-July-2019)(2)

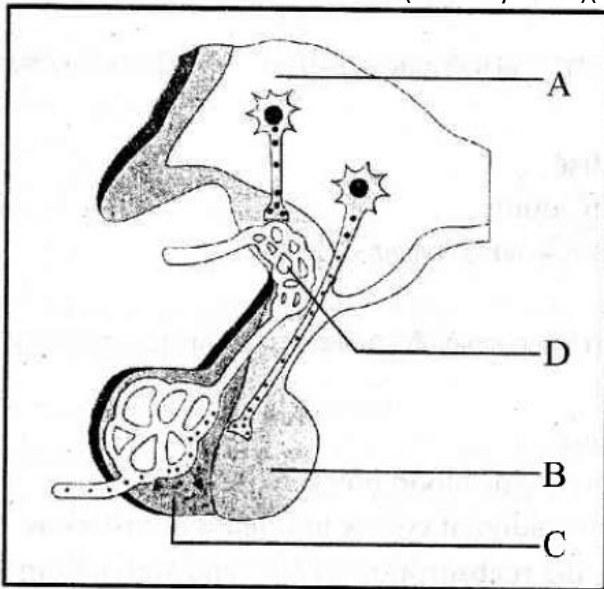

4. State whether the following statements are true/false. If false, correct it. (HSE-July-2019)(2)

- (a) ADH prevents diuresis.
- (b) ANF causes the increase of blood pressure.
- (c) Angiotensin-I activate adrenal cortex to release aldosterone.
- (d) aldosterone causes the reabsorption of Na⁺ and water from the distal part of renal tubule

5. Following are the hormones-produced by tissues other part than endocrine glands. Write the where it is produced and mention the functions of each

- (a) Cholecystokinin
- (b) Gastrin
- (c) Secretin (HSE-July-2019)(3)

6. Note the relationship in the first pair and then complete the second pair. (HSE-March-2019)(2)

- a) Insulin; Hypoglycemic hormone : ; Hyperglycemic hormone
b) Over secretion of Growth hormone; Gigantism: Low secretion of Growth hormone;

7. Anitha saw a poisonous snake on her way to school, she was frightened and her heart and breathing rate increased : (HSE-Model-2019)(2)

- (a) Name the hormones which are dominant at that time in her blood.
- (b) Which endocrine gland produce the hormone ?
- (c) To which organ this endocrine gland is attached?

8. Functions of certain hormones are given below. Identify the hormone. (HSE-Model-2019)(2)

- (a) Regulation of metabolism Differentiation of 'T' cells
- (b) Lower blood sugar
- (c) Support pregnancy and act on mammary gland

9. Expand the following hormones :

- a) TSH b) ACTH c) ANF d) FSH (HSE-Aug-2018)(2)

10. Complete the table given below by using appropriate terms (HSE-Aug-2018)(3)

Gland	Hormone	Function
Pancreas	Glucagon(a).....
.....(b).....	Thymosin	Immunity
Pineal gland(c).....	24-hr diurnal rhythm
Pituitary gland	Oxytocin(d).....
.....(e).....	Parathyroid hormone	Increases Ca ²⁺ level in blood
Thyroid	TCT/ Thyrocalcitonin(f).....

11. Name the hormones whose deficiency is responsible for the following :

- a) Dwarfism b) I)diabetes mellitus

c) Cretinism d) diabetes (HSE-March 2018)(2)

12. Classify the given hormones in the table

Prolactin, Oxytocin, Leutinisig hormone, Vasopressin (HSE-Model2018)(2)

Released from adenohipophysis	Released from neurohipophysis
-	-
-	-

13. Observe the following branching tree diagram (HSE-July-2017)(2)

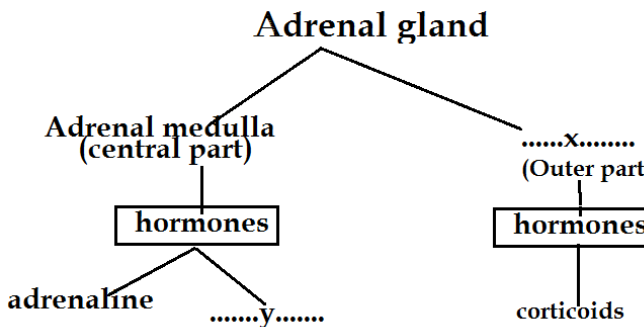

- a) Complete the representation by filling X and Y?
- b) Adrenal medullary hormones are called 'Hormones of fight or flight' why?

14. Complete the table (HSE-March-2017)(2)

Endocrine gland	Hormone	Functions
HeartA.....	Decrease blood pressure
Pancreas	InsulinB.....
.....C.....	Erythropoietin	Stimulate erthropoiesis
ThymusD.....	Gives Immunity

15. A table shown below based on their endocrine gland and their secretions. Complete it by filling A, B, C and D (HSE-sept-2016)(2)

16. Hormonal abnormality is responsible for certain disease in man. List of Some

Endocrine gland	Hormone	Functions
Pancreas (A)	Hypoglycemic hormone of blood
..... (B)	Thymosin	Provide immunity

- 17. disease are given below. Write the hormone related to it. (HSE-March-2016)(2)
- a) Diabetes mellitus
- b) Gigantism
- c) Diabetes insipidus
- d) Cretinism

or

- 18. Like insulin and Glucagon, PTH and calcitonin are antagonistic in their action in maintaining Blood calcium level. Substantiate your answer? (HSE-March-2016)(2)

- 19. Write any two examples for the following
- a) Hormone which control blood sugar level
- b) Hormones which control blood sugar level (HSE-sept-2015)(2)

20. Match column B and C with column A (HSE-March-2015)(2)

A	B	C
Thyroid	Insulin	Weak Immunity
Pituitary	Thymosin	Gigantism
Pancreas	Growth hormone	Diabetes mellitus
Thymus	Thyroxine	Goitre

21. Complete the following table? (HSE-August-2014)(2)

NAVAS CHEEMADAN

Hormone ഹോർമോൺ	Endocrine gland അന്തഃസ്രാവീ ഗ്രന്ഥി	Function ധർമ്മം
A	Ovary ഓവറി	Hormone supports pregnancy ഗർഭാവസ്ഥയെ സഹായിക്കുന്ന ഹോർമോൺ
Thyroxine തൈറോക്സിൻ	B	Hormone regulates BMR BMR നെ നിയന്ത്രിക്കുന്ന ഹോർമോൺ
Adrenaline അഡ്രിനാലിൻ	C	Emergency hormone എമർജൻസി ഹോർമോൺ
D	Pancreas പാൻക്രിയാസ്	Hyperglycemic hormone ഹൈപ്പർഗ്ലൈസെമിക് ഹോർമോൺ

22. Complete the following sentence using appropriate words (HSE-March-2014)(1)

- a).....Hormone controls diurnal (24hour)Rhythm
- b)Insulin controls.....level of blood

22. The output of urine increase in cold days while decreased in hot and sunny days. Can you give the reason for this phenomenon as realized from the graph given below ? (HSE-MARCH-2014)(2)

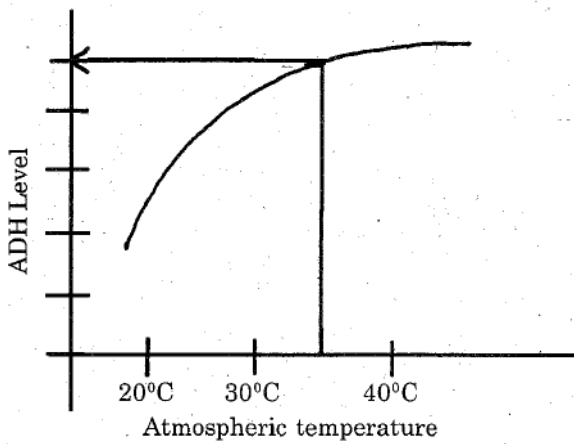

23. Observe the relationship between the first two terms and fill up the blanks (HSE-SEPT-2013)(1)

- Hyperglycemic hormone:Glucagon
- Hypoglycemic hormone:.....

24. Complete the chart showing hormone and Hormonal disease (HSE-SEPT-2013)(1)

SOHSS-AREEKODE

Diseases	Causes
Dwarfism	Low secretion of growth hormone
a) _____	Over-secretion of growth hormone
Goitre	Deficiency of iodine
Diabetes mellitus	b) _____

25. Fill the table appropriately (HSE-March-2013)(2)

Hormones	Site of production	Function
CCK	Gastrointestinal tract	a)
Erythropoietin	b)	RBC formation
c)	Heart	Reduced BP
PTH	d)	Increased blood Ca^{2+}

26. Match Column B and C with Column A (HSE-SEPT-2012)(2)

A Hormone	B Endocrine gland	C Principal function
1) Thyroxin	i) Adrenal gland	a) Contraction of smooth muscles
2) Oxytocin	ii) Thymus gland	b) Stimulates ovulation
	iii) Pitutory gland	c) Regulates basal metabolic rate
	iv) Thyroid gland	d) Increases calcium level in the blood

NAVAS CHEEMADAN

SOHSS-AREEKODE

navas9895@gmail.com

navas9895@gmail.com

NAVAS CHEEMADAN