

## 3. Electromagnetic Induction

### Focus Area

1. Electromagnetic Induction, Factors affecting the induced emf
2. AC generator – Structure and Working
3. DC generator – Structure and Working
4. AC generator DC generator and Cell – Characteristics and graphical representation
5. Mutual Induction, Transformer - Structure and Working
6. Moving Coil Microphone
7. Power Transmission in high voltage
8. Electric Shock – Precautions and First aid

### 1. Electromagnetic Induction, Factors affecting the induced emf



Sl. No.	Experimental procedure	Observation (Galvanometer needle)	
		Deflects/ does not deflect	Direction to the left/ to the right
1	The magnet is stationary near the solenoid	<b>Does not deflect</b>	
2	North pole of the magnet is moved into the solenoid	<b>Deflect</b>	<b>To the left</b>
3	The magnet is stationary inside the solenoid	<b>Does not deflect</b>	
4	The magnet is moved out of the solenoid.	<b>Deflect</b>	<b>To the right</b>
5	The south pole of the magnet is moved into the solenoid	<b>Deflect</b>	<b>To the right</b>
6	Magnet and solenoid are moved in the same direction at the same speed	<b>Does not deflect</b>	
7	The solenoid is moved keeping the magnet stationary	<b>Deflect</b>	<b>left or right</b>

Why did the galvanometer needle deflect in the experiment?

\* Whenever there is a change in the magnetic flux linked with a coil, an emf is induced in the coil.

Which were the instances in which there was a flow of current through the solenoid?

\* Whenever there is a relative motion between the magnet and the solenoid, there is flow of electricity.

\* Whenever there is a change in the magnetic flux linked with a coil, an emf is induced in the coil. This phenomenon is electro-magnetic induction.

What may be the factors affecting the induced emf?

- \* Number of turns of the coiled conductor
- \* Strength of the magnet
- \* Movement of magnet and solenoid

## 2. AC generator – Structure and Working

Working principle : Electromagnetic Induction

Energy change : Mechanical Energy → Electrical Energy

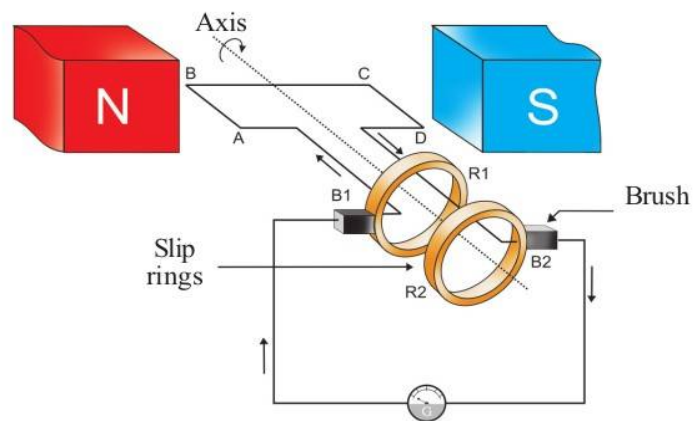
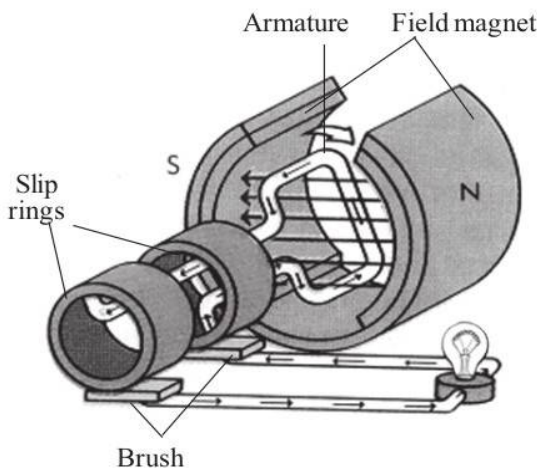

### The main Parts of AC generator

\* Field magnet (NS)

The magnet that creates magnetic flux in the generator.

\* Armature (ABCD)

An arrangement of insulated conducting wire wound on a soft iron core. This can be made to rotate about an axis.

\* Slip rings (R1,R2)

Metal rings which are welded together with the armature coil. They rotate along with the armature on the same axis of rotation as the armature

\* Brushes(B1,B2)

They are arrangements which always make contact with the slip rings. Current flows through them to the external circuits.

\* When the coil rotates about the axis in the clockwise direction, the portion AB moves upward and the portion CD moves downward.

Then according to the Fleming's Right Hand Rule . What is the direction of induced current in the portion AB?

\* From A to B

What is the direction of induced current in the portion CD?

\* From C to D

What is the direction of induced current in the coil ABCD?

\* From A to D

What is the direction of induced current in the external circuit? (through the galvanometer)

\* From B 2 to B 1

What will be the positions of AB and CD when the armature completes  $180^\circ$  or one half rotation?

\* AB will be near the south pole of the magnet and CD will be near the north pole.

At this instance, What is the direction of movement of AB?

\* Downward

What is the direction of movement of CD?

\* Upward

What is the direction of current in the armature?

\* From D to A

What is the direction of current through the external circuit (through the galvanometer)?

\* From B1 to B2

\* The direction of current reverses during every half rotation of the armature and that the magnitude of current is increasing and decreasing.

Stages of rotation of an armature coil while completing one rotation in a magnetic field

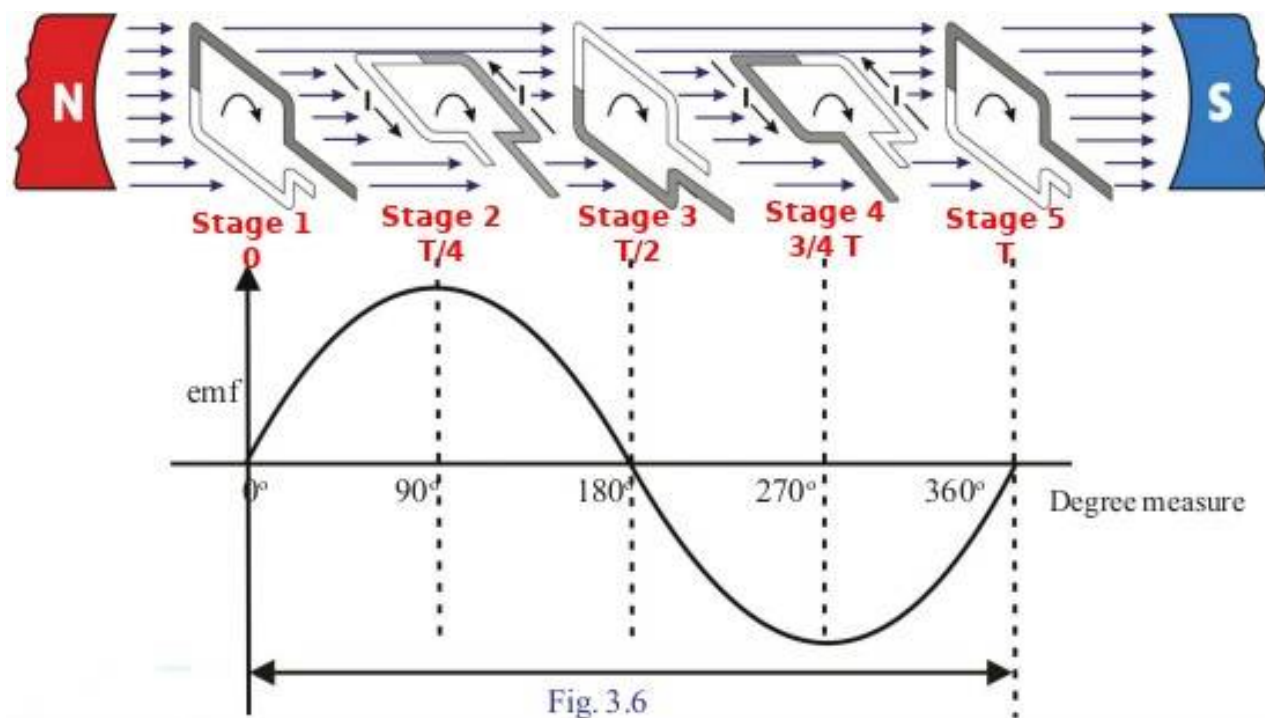

Stage 1 (angle of rotation 0 ,Time 0)

- \* The plane of armature coil is perpendicular to the direction of magnetic field.
- \* The rate of change of Flux is zero.
- \* Induced current in the coil is zero.

Stage 2 (angle of rotation 90 ,Time T/4)

- \* The plane of armature coil is parallel to the direction of magnetic field.
- \* The rate of change of Flux is maximum.
- \* Induced current in the coil is maximum.

Stage 3 (angle of rotation 180 ,Time T/2)

- \* The plane of armature coil is perpendicular to the direction of magnetic field.
- \* The rate of change of Flux is zero.
- \* Induced current in the coil is zero.

Stage 4 (angle of rotation 270 ,Time 3/4T)

- \* The plane of armature coil is parallel to the direction of magnetic field.
- \* The rate of change of Flux is maximum in the opposite direction.
- \* Induced current in the coil is maximum in the opposite direction.

Stage 5 (angle of rotation 360 ,Time T)

- \* The plane of armature coil is perpendicular to the direction of magnetic field.
- \* The rate of change of Flux is zero.
- \* Induced current in the coil is zero.

Period T

The time taken by the armature coil for a full rotation is called the period, T. Time taken for half rotation (180°) is T/2.

The frequency of AC

- \* In an AC generator, the induced emf generated in the first half rotation in one direction and that generated in the second half rotation in the opposite direction together form the cycle of AC.
- \* The number of cycles per second is the frequency of AC.
- \* The frequency of AC generated for distribution in our country is 50 cycles per second or 50 Hz.
- \* If the frequency of AC is to be 50 Hz, the armature coil is to rotate fifty times per second. How to overcome this practical difficulties?  
The number of rotations is reduced by increasing the number of armature coils and the number of pole pieces of the field magnet in a generator.

3. DC generator – Structure and Working

Working principle : Electromagnetic Induction

Energy change : Mechanical Energy → Electrical Energy

The main Parts of DC generator

- \* Field magnet (NS)
- \* Armature (ABCD)
- \* Split ring commutator (R1,R2)
- \* Brushes(B1,B2)

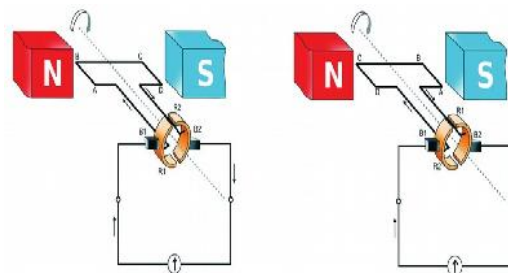

If split ring commutator is used in a generator instead of slip rings Though AC current is produced in a DC generator with the help of split ring commutator AC is converted into DC . The AC generated in the armature becomes DC in the external circuit as a result of the change in contact between the ring and the brush at each half-rotation of the armature

\* What are the similarities between the DC motor and a DC generator?

Permanent magnet.

Armature

Brushes

Split rings

\* Connect the output of a small DC generator to a galvanometer and rotate the armature continuously. How is the needle deflected?

\* Same direction

Is the direction of current changing?

\* No

Is the magnitude of current the same?

\* No. Emf increases and decreases

#### 4. AC generator , DC generator and Cell – Characteristics and graphical representation

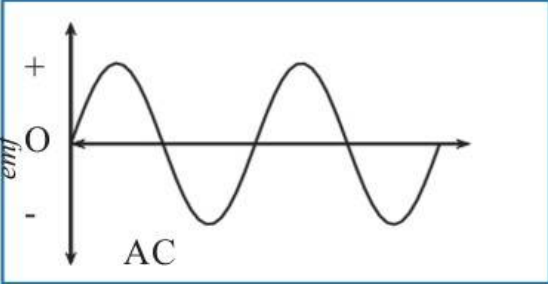
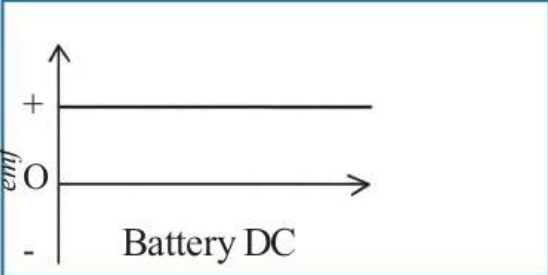
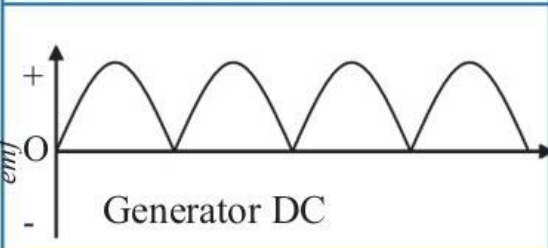
	<ul style="list-style-type: none"> <li>• Direction changes continuously</li> <li>• <b>emf increases and decreases</b></li> </ul>
	<ul style="list-style-type: none"> <li>• <b>Direction constant</b></li> <li>• <b>emf constant</b></li> </ul>
	<ul style="list-style-type: none"> <li>• <b>Direction constant</b></li> <li>• emf increases and decreases.</li> </ul>

## 5. Mutual Induction, Transformer - Structure and Working

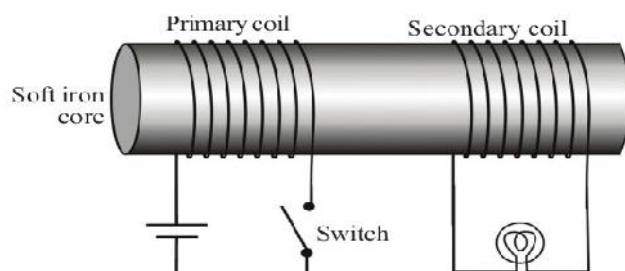

Fig. 3.8

1. Turn on & turn off the switch continuously. What do you observe?

\* Bulb glows and then goes off

2. If the switch is kept in the on position what do you observe?

\* Bulb does not glow

3. On what occasions do the flux change?

\* Turn on & turn off the switch continuously.

4. What are the occasions when current flows through the second coil?

\* When the switch in the first coil is kept on or off

\* The coil into which we give current for the production of magnetic field is the primary coil and the coil in which induced emf is generated is the secondary coil.

5. Can you suggest a method by which change can be brought in magnetic flux without switching on and off continuously?

\* If AC is given to the primary coil instead of DC, emf will be continuously induced in the secondary coil.

6. What is this phenomenon? Explain.

\* Mutual induction

Consider two coils of wire kept side by side. When the strength or direction of the current in one coil changes, the magnetic flux around it changes. As a result, an emf is induced in the secondary coil. This phenomenon is the mutual induction



## Transformer

Working Principle : Mutual induction

→ Transformer is a device for increasing or decreasing the voltage of an AC without any change in the electric power.

→ Transformers are of two types

- Step up transformer
- Step down transformer

### Difference between Step up transformer and Step down transformer

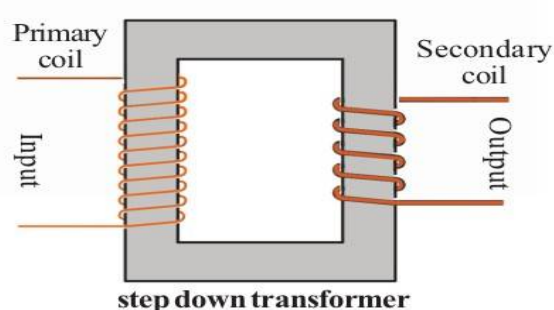
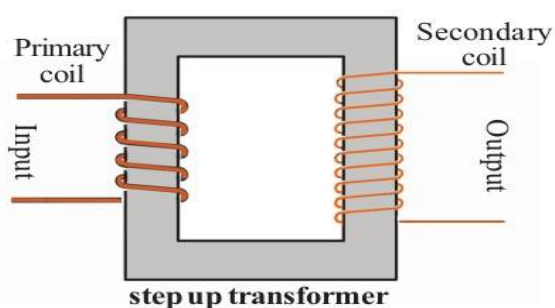

Step up transformer	Step down transformer
Thick wires are used in the Primary.	Thick wires are used in the Secondary.
Less number of turns are used in the Primary	Less number of turns are used in the Secondary
Thin wires are used in the Secondary.	Thin wires are used in the Primary.

→ The emf in each turn of the primary and the secondary coils will be the same.  
 → Let the emf in one turn be  $\epsilon$

Then, the emf in the primary is  $V_p = N_p \times \epsilon$

The induced emf in the secondary is  $V_s = N_s \times \epsilon$

### The relation between the voltage and the number of turns of a transformer



- The voltage is directly proportional to the number of turns (The voltage increases as the number of turns increases and the voltage decreases as the number of turns decreases)

The primary voltage -  $V_p$   
 The number of turns in the primary -  $N_p$   
 The secondary voltage -  $V_s$   
 The number of turns in the secondary -  $N_s$   
 Then

$$\frac{V_s}{V_p} = \frac{N_s}{N_p}$$

The relation between the voltage and the current of a transformer

- The voltage is indirectly proportional to the current (The voltage increases as the current decreases and the voltage decreases as the current increases)
- If there is no loss of power from a transformer
- The power in the primary and the secondary coils of a transformer is the same.

Power = Voltage x Current  
 Primary power,  $V_p \times I_p$  = secondary power,  $V_s \times I_s$

That is  $V_p \times I_p = V_s \times I_s$

$$\therefore \frac{I_p}{I_s} = \frac{V_s}{V_p}$$

In a step up transformer the voltage in the secondary coil is more and the current is less. But in a step down transformer the secondary voltage is less and the current is more.

1. A transformer working on a 240 V AC supplies a voltage of 8 V to an electric bell in the circuit. The number of turns in the primary coil is 4800. Calculate the number of turns in the secondary coil.

The primary voltage  $V_p = 240 \text{ V}$   
 The number of turns in the primary  $N_p = 4800 \text{ turns}$   
 The secondary voltage  $V_s = 8 \text{ V}$   
 The number of turns in the secondary  $N_s = ?$

$$\frac{V_s}{V_p} = \frac{N_s}{N_p}$$

$$N_s = (V_s \times N_p) / V_p$$

$$= (8 \times 4800) / 240$$

$$= 38400/240$$

$$N_s = 160 \text{ turns}$$

2. The input voltage of a transformer is 240 V AC. There are 80 turns in the secondary coil and 800 turns in the primary. What is the output voltage of the transformer?

The primary voltage  $V_p = 240 \text{ V}$   
 The number of turns in the primary  $N_p = 800 \text{ turns}$   
 The secondary voltage  $V_s = ?$   
 The number of turns in the secondary  $N_s = 80 \text{ turns}$

$$\frac{V_s}{V_p} = \frac{N_s}{N_p}$$

$$V_s = (N_s \times V_p) / N_p$$

$$= (80 \times 240) / 800$$

$$= 19200/800$$

$$V_s = 24 \text{ V}$$

Examine the Table and answer the following questions.

Transformer	Primary			Secondary		
	Total voltage $V_p$	No. of turns $N_p$	Voltage in one turn ( $\epsilon$ ) $V_p/N_p$	Total voltage $V_s$	No. of turns $N_s$	Voltage in one turn ( $\epsilon$ ) $V_s/N_s$
T1	500 V	100	5 V	50 V	10	5 V
T2	20 V	10	2 V	200 V	100	2 V
T	$N_p \times \epsilon$	$N_p$	$\epsilon$	$N_s \times \epsilon$	$N_s$	$\epsilon$

1. What kind of transformers are T1 and T2 ?
  - T1 – Step down transformer
  - T2 – Step up transformer
2. What is the voltage in one turn when 500 V is given as input in T1 primary?
  - 5 V
3. Is there a change in one turn voltage of the same transformer when the output voltage decreases to 50 V?
  - No change
4. Is there a voltage change in each one turn of the primary and secondary in the step up transformer T2?
  - No change
5. How the ratio of voltages to the number of turns in each of the transformers, primary and secondary is related? Write this ratio in mathematical form.
  - The voltage is directly proportional to the number of turns

$$\frac{V_s}{V_p} = \frac{N_s}{N_p}$$

6. What could be the reason for using thicker wire windings in the primary of a step up transformer and the secondary of a step down transformer?
  - The primary and secondary power of a transformer will be equal. Therefore the current in the primary of the step up transformer and the secondary of the step down transformer will be higher. So thicker wires will be used to prevent the coil from overheating. Thicker wires have less resistance.

\* In a transformer without any loss in power, there are 5000 turns in the primary and 250 turns in the secondary. The primary voltage is 120 V and the primary current is 0.1 A. Find the voltage and current in the secondary.

Primary voltage	$V_p = 120 \text{ V}$
No. of turns in the primary	$N_p = 5000 \text{ turns}$
No. of turns in the secondary	$N_s = 250 \text{ turns}$
Primary current	$I_p = 0.1 \text{ A}$
Secondary voltage	$V_s = ?$

Secondary current

$$I_s = ?$$

$$\frac{V_s}{V_p} = \frac{N_s}{N_p}$$

Secondary voltage

$$\begin{aligned} V_s &= (N_s \times V_p)/N_p \\ &= (250 \times 120)/5000 \\ &= 6 \text{ V} \end{aligned}$$

$$V_p \times I_p = V_s \times I_s$$

Secondary current

$$\begin{aligned} I_s &= (V_p \times I_p)/V_s \\ &= (120 \times 0.1)/6 \\ &= 2 \text{ A} \end{aligned}$$

## 6. Moving Coil Microphone

\* Working principle : Electromagnetic induction

\* What is the energy transformation that takes place in a moving coil microphone?

➤ Mechanical energy - Electrical energy.

\* Which are the main parts of a moving coil microphone?

➤ Diaphragm, Permanent magnet and voice coil.

\* Which is the moving part in it?

➤ Diaphragm and voice coil

\* If a sound is produced in front of a movable diaphragm, what will happen to the diaphragm?

➤ Diaphragm Vibrate corresponding to the sound signals.

\* What happens to the voice coil then?

➤ Vibrate

\* What will be the result?

➤ Creates electric signal corresponding to the sound

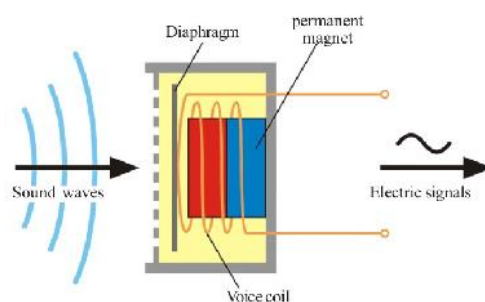

### The working of Moving coil microphone

When a sound is produced in front of a microphone



The diaphragm connected to the voice coil vibrates in accordance with the sound waves falling on it



As a result, electrical signals corresponding to the sound waves are generated in the voice coil.



The weak signals obtained from the microphone are strengthened by an amplifier.



The signals reaching the amplifier are strengthened and sent to the loud speaker.



The loud speaker reproduces the original sound.

\* Find out the similarities and differences between a moving coil microphone and a moving coil loud speaker

	moving coil microphone	moving coil loud speaker
Similarities	Voice coil Permanent magnetic Diaphragm	Voice coil Permanent magnetic Diaphragm
Differences	Mechanical energy – Electrical energy	Electrical energy – Mechanical energy
	Electromagnetic induction	Motor Principle

## 7. Power Transmission in high voltage

### Transmission loss.

- ➔ When electricity is transmitted to distant places there is loss of energy in the conductors in the form of heat. This is known as transmission loss.
- ➔ In India electricity is produced at 11 kV (11000 V) in power stations.

→ What are the methods to reduce the heat generated?

- Reduce current
- Reduce Resistance
- Reduce the time taken

→ How can we reduce the current without change in power? Find out on the basis of the equation  $P = V \times I$ .

By increasing the Voltage.

→ What is the method to reduce the transmission loss?

The voltage is increased up to 220 kV at the power station itself (Depending on the distance to which the transmission is to be done, different voltages like 110 kV, 400 kV, are also made use of). As a result the current and loss of energy in the form of heat decreases.

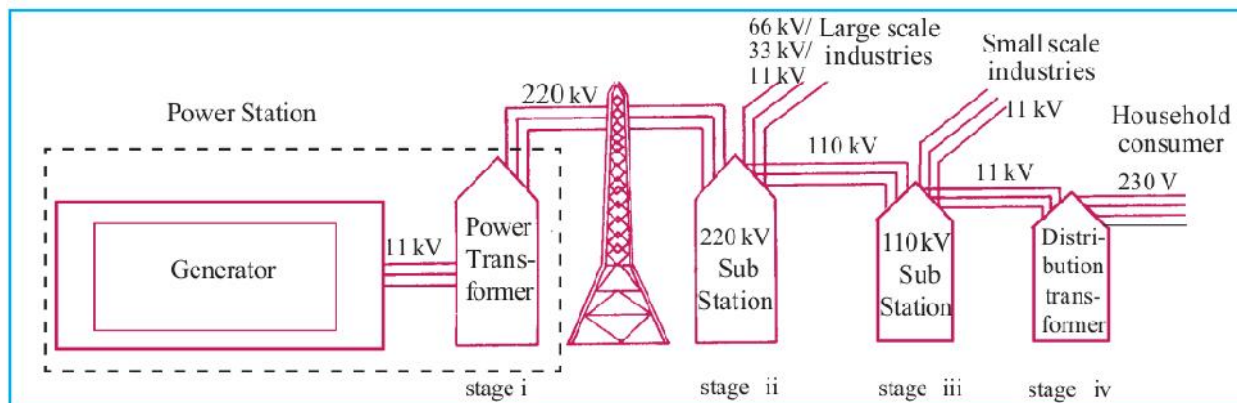

Different stages of electric power transmission

→ Which type of transformer is there in a power station?

Step up transformer

→ Which type of transformer is there in a sub station?

Step down transformer

→ Which type of transformer is a distribution transformer?

Step down transformer

→ How many lines reach the distribution transformer?

3 lines (11 KV)

→ How many lines go out of the distribution transformer?

4 lines (3 Phase line and 1 neutral line)

- What is the potential difference between 2 phase lines?  
400 V
- What is the potential difference between any one phase line and the neutral line?  
230 V
- What is the potential difference between the earth and the neutral line?  
0 V
- Which are the lines essential for household electrification?  
Phase line, Neutral line, and Earth line.
- If a person standing on the earth touches a phase line, will she get an electric shock? Why?  
The person will get an electric shock because there is a potential difference (230 V) between phase and earth.

### 8. Electric Shock – Precautions and First aid

\* what are the precautions to be taken to avoid electric shock.?

#### Precautions

- Never handle electric equipments or operate switches when the hands are wet.
- Insert plug pins into socket and withdraw them only after switching off.
- Do not operate devices of high power using ordinary sockets.
- Wear rubber footwear while operating electric devices.
- Do not touch the interior parts of the cable TV adapters. Ensure that there is an insulated cap for the adapters.
- Do not fly kites near electric lines.
- Do not use table fan to dry hair.
- Ensure that there are no tall buildings or tall trees near electric lines.
- Ensure that the main switch and ELCB are switched off when maintenance work is being carried out at home.



### Precautions during some Special Circumstances

- During lightning, avoid doing any work that will bring you in contact with electric circuits. (There is a possibility of excess current in the circuit during lightning)
- Disconnect the plugs from the socket whenever there is a chance of lightning.
- During rain and wind, electric lines are likely to touch the ground. This may cause danger. We have to be cautious on such occasions.
- If water enters home due to floods or other reasons, disconnect electric connections. Reconnect it only after ensuring that the main switch and the switch board are perfectly dry.

### First aid to be given in the case of electric shock

\* As a result of electric shock, the body temperature of the victim decreases, viscosity of blood increases and clotting of blood occurs. In addition, muscles of the body contract.

First aid should be given only after disconnecting the victim from the electric wire.

### How to provide the first aid:

- Raise the temperature of the body by massaging.
- Give artificial respiration.
- Massage the muscles and bring them to the original condition.
- Start first aid for the functioning of the heart (Apply pressure on the chest regularly)
- Take the person to the nearest hospital immediately.

”Saving electricity is equivalent to generating electricity”