

# GATE EC

## 2009

**Q.1 - Q.20 carry one mark each.**

**MCQ 1.1** The order of the differential equation

$$\frac{d^2 y}{dt^2} + \left(\frac{dy}{dt}\right)^3 + y^4 = e^{-t}$$

is

(A) 1

(B) 2

(C) 3

(D) 4

**SOL 1.1** The highest derivative terms present in DE is of 2nd order.  
Hence (B) is correct answer.

**MCQ 1.2** The Fourier series of a real periodic function has only

(P) cosine terms if it is even

(Q) sine terms if it is even

(R) cosine terms if it is odd

(S) sine terms if it is odd

Which of the above statements are correct ?

(A) P and S

(B) P and R

(C) Q and S

(D) Q and R

**SOL 1.2** The Fourier series of a real periodic function has only cosine terms if it is even and sine terms if it is odd.

Hence (A) is correct answer.

**MCQ 1.3** A function is given by  $f(t) = \sin^2 t + \cos 2t$ . Which of the following is true ?

(A)  $f$  has frequency components at 0 and  $\frac{1}{2\pi}$  Hz

(B)  $f$  has frequency components at 0 and  $\frac{1}{\pi}$  Hz

(C)  $f$  has frequency components at  $\frac{1}{2\pi}$  and  $\frac{1}{\pi}$  Hz

(D)  $f$  has frequency components at  $\frac{0.1}{2\pi}$  and  $\frac{1}{\pi}$  Hz

**SOL 1.3**

Given function is

$$f(t) = \sin^2 t + \cos 2t = \frac{1 - \cos 2t}{2} + \cos 2t = \frac{1}{2} + \frac{1}{2} \cos 2t$$

The function has a DC term and a cosine function. The frequency of cosine terms is

$$\omega = 2 = 2\pi f \rightarrow f = \frac{1}{\pi} \text{ Hz}$$

The given function has frequency component at 0 and  $\frac{1}{\pi}$  Hz.

Hence (B) is correct answer.

**MCQ 1.4**

A fully charged mobile phone with a 12 V battery is good for a 10 minute talk-time. Assume that, during the talk-time the battery delivers a constant current of 2 A and its voltage drops linearly from 12 V to 10 V as shown in the figure. How much energy does the battery deliver during this talk-time?

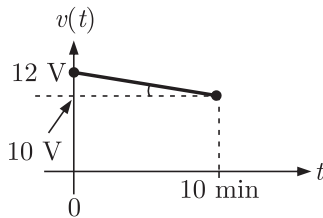

(A) 220 J

(C) 13.2 kJ

(B) 12 kJ

(D) 14.4 J

**SOL 1.4**

The energy delivered in 10 minutes is

$$\begin{aligned} E &= \int_0^t VI dt = I \int_0^t V dt = I \times \text{Area} \\ &= 2 \times \frac{1}{2} (10 + 12) \times 600 = 13.2 \text{ kJ} \end{aligned}$$

Hence (C) is correct option.

**MCQ 1.5**

In an n-type silicon crystal at room temperature, which of the following can have a concentration of  $4 \times 10^{19} \text{ cm}^{-3}$ ?

(A) Silicon atoms

(C) Dopant atoms

(B) Holes

(D) Valence electrons

**SOL 1.5**

Only dopant atoms can have concentration of  $4 \times 10^{19} \text{ cm}^{-3}$  in n-type silicon at room temperature.

Hence option (C) is correct.

**MCQ 1.6**

The full form of the abbreviations TTL and CMOS in reference to logic families are

(A) Triple Transistor Logic and Chip Metal Oxide Semiconductor

(B) Tristate Transistor Logic and Chip Metal Oxide Semiconductor

(C) Transistor Transistor Logic and Complementary Metal Oxide Semiconductor

(D) Tristate Transistor Logic and Complementary Metal Oxide Silicon

**SOL 1.6** TTL → Transistor - Transistor logic  
 CMOS → Complementary Metal Oxide Semi-conductor  
 Hence (C) is correct answer.

**MCQ 1.7** The ROC of  $z$ -transform of the discrete time sequence

$$x(n) = \left(\frac{1}{3}\right)^n u(n) - \left(\frac{1}{2}\right)^n u(-n-1)$$

- (A)  $\frac{1}{3} < |z| < \frac{1}{2}$  (B)  $|z| > \frac{1}{2}$   
 (C)  $|z| < \frac{1}{3}$  (D)  $2 < |z| < 3$

**SOL 1.7** Hence (A) is correct answer

$$x[n] = \left(\frac{1}{3}\right)^n u(n) - \left(\frac{1}{2}\right)^n u(-n-1)$$

Taking  $z$  transform we have

$$\begin{aligned} X(z) &= \sum_{n=0}^{\infty} \left(\frac{1}{3}\right)^n z^{-n} - \sum_{n=-\infty}^{-1} \left(\frac{1}{2}\right)^n z^{-n} \\ &= \sum_{n=0}^{\infty} \left(\frac{1}{3} z^{-1}\right)^n - \sum_{n=-\infty}^{-1} \left(\frac{1}{2} z^{-1}\right)^n \end{aligned}$$

First term gives  $\frac{1}{3} z^{-1} < 1 \rightarrow \frac{1}{3} < |z|$

Second term gives  $\frac{1}{2} z^{-1} > 1 \rightarrow \frac{1}{2} > |z|$

Thus its ROC is the common ROC of both terms. that is

$$\frac{1}{3} < |z| < \frac{1}{2}$$

**MCQ 1.8** The magnitude plot of a rational transfer function  $G(s)$  with real coefficients is shown below. Which of the following compensators has such a magnitude plot ?

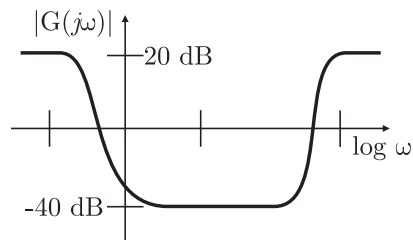

- (A) Lead compensator (B) Lag compensator  
 (C) PID compensator (D) Lead-lag compensator

**SOL 1.8** This compensator is roughly equivalent to combining lead and lag compensators in the same design and it is referred also as PID compensator.  
 Hence (C) is correct option

**MCQ 1.9** A white noise process  $X(t)$  with two-sided power spectral density  $1 \times 10^{-10}$  W/Hz

is input to a filter whose magnitude squared response is shown below.

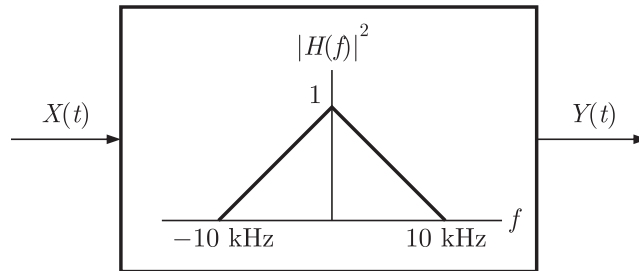

The power of the output process  $Y(t)$  is given by

- (A)  $5 \times 10^{-7}$  W (B)  $1 \times 10^{-6}$  W  
(C)  $2 \times 10^{-6}$  W (D)  $1 \times 10^{-5}$  W

**SOL 1.9** Correct Option is ( )

**MCQ 1.10** Which of the following statements is true regarding the fundamental mode of the metallic waveguides shown ?

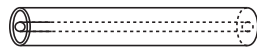

P: Coaxial



Q: Cylindrical

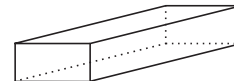

R: Rectangular

- (A) Only  $P$  has no cutoff-frequency  
(B) Only  $Q$  has no cutoff-frequency  
(C) Only  $R$  has no cutoff-frequency  
(D) All three have cutoff-frequencies

**SOL 1.10** Rectangular and cylindrical waveguide doesn't support TEM modes and have cut off frequency.

Coaxial cable support TEM wave and doesn't have cut off frequency.

Hence (A) is correct option.

**MCQ 1.11** A fair coin is tossed 10 times. What is the probability that only the first two tosses will yield heads?

- (A)  $\left(\frac{1}{2}\right)^2$  (B)  ${}^{10}C_2\left(\frac{1}{2}\right)^2$   
(C)  $\left(\frac{1}{2}\right)^{10}$  (D)  ${}^{10}C_2\left(\frac{1}{2}\right)^{10}$

**SOL 1.11** Number of elements in sample space is  $2^{10}$ . Only one element  $\{H, H, T, T, T, T, T, T, T, T, T\}$  is event. Thus probability is  $\frac{1}{2^{10}}$   
Hence (C) is correct answer.

**MCQ 1.12** If the power spectral density of stationary random process is a sine-squared function of frequency, the shape of its autocorrelation is

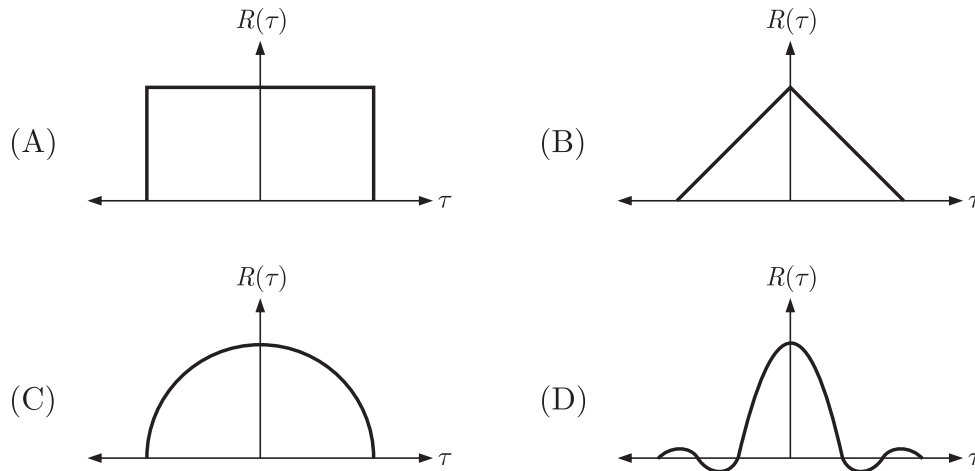

**SOL 1.12** Correct Option is ( )

**MCQ 1.13** If  $f(z) = c_0 + c_1z^{-1}$ , then  $\oint_{\text{unit circle}} \frac{1+f(z)}{z} dz$  is given by

- (A)  $2\pi c_1$
- (B)  $2\pi(1 + c_0)$
- (C)  $2\pi j c_1$
- (D)  $2\pi(1 + c_0)$

**SOL 1.13** Hence (C) is correct answer  
We have

$$f(z) = c_0 + c_1z^{-1}$$

$$f_1(z) = \frac{1+f(z)}{z} = \frac{1+c_0+c_1z^{-1}}{z} = \frac{z(1+c_0)+c_1}{z^2}$$

Since  $f_1(z)$  has double pole at  $z = 0$ , the residue at  $z = 0$  is

$$\text{Res } f_1(z)_{z=0} = \lim_{z \rightarrow 0} z^2 \cdot f_1(z) = \lim_{z \rightarrow 0} z^2 \cdot \left( \frac{z(1+c_0)+c_1}{z^2} \right) = c_1$$

Hence

$$\oint_{\text{unit circle}} f_1(z) dz = \oint_{\text{unit circle}} \frac{[1+f(z)]}{z} dz = 2\pi j [\text{Residue at } z = 0]$$

$$= 2\pi j c_1$$

**MCQ 1.14** In the interconnection of ideal sources shown in the figure, it is known that the 60 V source is absorbing power.

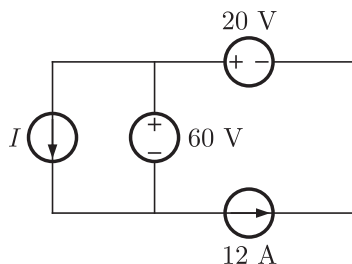

Which of the following can be the value of the current source  $I$ ?

- (A) 10 A (B) 13 A  
(C) 15 A (D) 18 A

**SOL 1.14** Circuit is as shown below

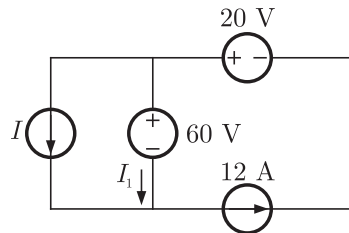

Since 60 V source is absorbing power. So, in 60 V source current flows from + to - ve direction

$$\text{So, } I + I_1 = 12$$

$$I = 12 - I_1$$

$I$  is always less than 12 A. So, only option (A) satisfies this condition.

Hence (A) is the correct option.

**MCQ 1.15** The ratio of the mobility to the diffusion coefficient in a semiconductor has the units

- (A)  $V^{-1}$  (B)  $\text{cm} \cdot V^{-1}$   
(C)  $V \cdot \text{cm}^{-1}$  (D)  $V \cdot s$

**SOL 1.15** Hence option (A) is correct.

$$\text{Unit of mobility } \mu_n \text{ is } = \frac{\text{cm}^2}{V \cdot \text{sec}}$$

$$\text{Unit of diffusion current } D_n \text{ is } = \frac{\text{cm}^2}{\text{sec}}$$

$$\text{Thus unit of } \frac{\mu_n}{D_n} \text{ is } = \frac{\text{cm}^2}{V \cdot \text{sec}} / \frac{\text{cm}^2}{\text{sec}} = \frac{1}{V} = V^{-1}$$

**MCQ 1.16** In a microprocessor, the service routine for a certain interrupt starts from a fixed location of memory which cannot be externally set, but the interrupt can be delayed or rejected. Such an interrupt is

- (A) non-maskable and non-vectored  
(B) maskable and non-vectored  
(C) non-maskable and vectored  
(D) maskable and vectored

**SOL 1.16** Vectored interrupts : Vectored interrupts are those interrupts in which program control is transferred to a fixed memory location.

Maskable interrupts : Maskable interrupts are those interrupts which can be rejected.

or delayed by microprocessor if it is performing some critical task.  
Hence (D) is correct answer.

**MCQ 1.17** If the transfer function of the following network is

$$\frac{V_o(s)}{V_i(s)} = \frac{1}{2 + sCR}$$

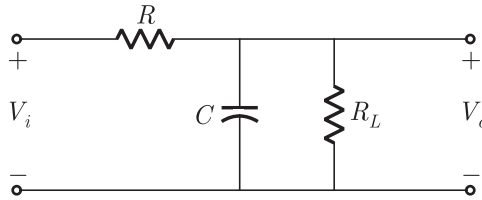

The value of the load resistance  $R_L$  is

- (A)  $\frac{R}{4}$  (B)  $\frac{R}{2}$   
(C)  $R$  (D)  $2R$

**SOL 1.17** For given network we have

$$V_0 = \frac{(R_L \parallel X_C) V_i}{R + (R_L \parallel X_C)}$$

$$\frac{V_0(s)}{V_i(s)} = \frac{\frac{R_L}{1 + sR_L C}}{R + \frac{R_L}{1 + sR_L C}} = \frac{R_L}{R + \frac{R_L}{1 + sR_L C}} = \frac{R_L}{R + \frac{R_L}{1 + sR_L C}}$$

$$= \frac{R_L}{R + \frac{R R_L s C + R_L}{1 + sR_L C}} = \frac{R_L}{1 + \frac{R}{R_L} + R s C}$$

But we have been given

$$T.F. = \frac{V_0(s)}{V_i(s)} = \frac{1}{2 + sCR}$$

Comparing, we get

$$1 + \frac{R}{R_L} = 2 \Rightarrow R_L = R$$

Hence (C) is correct option.

**MCQ 1.18** Consider the system

$$\frac{dx}{dt} = Ax + Bu \quad \text{with} \quad A = \begin{bmatrix} 1 & 0 \\ 0 & 1 \end{bmatrix} \quad \text{and} \quad B = \begin{bmatrix} p \\ q \end{bmatrix}$$

where  $p$  and  $q$  are arbitrary real numbers. Which of the following statements about the controllability of the system is true ?

- (A) The system is completely state controllable for any nonzero values of  $p$  and  $q$   
(B) Only  $p = 0$  and  $q = 0$  result in controllability  
(C) The system is uncontrollable for all values of  $p$  and  $q$

(D) We cannot conclude about controllability from the given data

**SOL 1.18** Hence (C) is correct option.

$$\text{Here } A = \begin{bmatrix} 1 & 0 \\ 0 & 1 \end{bmatrix} \text{ and } B = \begin{bmatrix} p \\ q \end{bmatrix}$$

$$AB = \begin{bmatrix} 1 & 0 \\ 0 & 1 \end{bmatrix} \begin{bmatrix} p \\ q \end{bmatrix} = \begin{bmatrix} p \\ q \end{bmatrix}$$

$$S = [B \ AB] = \begin{bmatrix} p & q \\ q & p \end{bmatrix}$$

$$S = pq - pq = 0$$

Since  $S$  is singular, system is completely uncontrollable for all values of  $p$  and  $q$ .

**MCQ 1.19** For a message signal  $m(t) = \cos(2\pi f_m t)$  and carrier of frequency  $f_c$ , which of the following represents a single side-band (SSB) signal ?

(A)  $\cos(2\pi f_m t) \cos(2\pi f_c t)$

(B)  $\cos(2\pi f_c t)$

(C)  $\cos[2\pi(f_c + f_m)t]$

(D)  $[1 + \cos(2\pi f_m t) \cos(2\pi f_c t)]$

**SOL 1.19** Hence (C) is correct option.

$$\cos(2\pi f_m t) \cos(2\pi f_c t) \rightarrow \text{DSB suppressed carrier}$$

$$\cos(2\pi f_c t) \rightarrow \text{Carrier Only}$$

$$\cos[2\pi(f_c + f_m)t] \rightarrow \text{USB Only}$$

$$[1 + \cos(2\pi f_m t) \cos(2\pi f_c t)] \rightarrow \text{USB with carrier}$$

**MCQ 1.20** Two infinitely long wires carrying current are as shown in the figure below. One wire is in the  $y-z$  plane and parallel to the  $y$ -axis. The other wire is in the  $x-y$  plane and parallel to the  $x$ -axis. Which components of the resulting magnetic field are non-zero at the origin ?

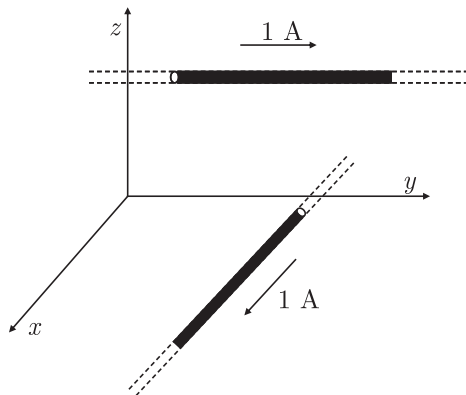

(A)  $x, y, z$  components

(B)  $x, y$  components

(C)  $y, z$  components

(D)  $x, z$  components

**SOL 1.20** Due to 1 A current wire in  $x-y$  plane, magnetic field at origin will be in  $x$  direction.

Due to 1 A current wire in  $y-z$  plane, magnetic field at origin will be in  $z$



direction.

Thus  $x$  and  $z$  component is non-zero at origin.

Hence (D) is correct option.

**Q.21 to Q.60 carry two marks each.**

- MCQ 1.21** Consider two independent random variables  $X$  and  $Y$  with identical distributions. The variables  $X$  and  $Y$  take values 0, 1 and 2 with probabilities  $\frac{1}{2}, \frac{1}{4}$  and  $\frac{1}{4}$  respectively. What is the conditional probability  $P(X + Y = 2 | X - Y = 0)$  ?
- (A) 0 (B)  $\frac{1}{16}$   
 (C)  $\frac{1}{6}$  (D) 1

**SOL 1.21** Hence (C) is correct option.

We have

$$p(X = 0) = p(Y = 0) = \frac{1}{2}$$

$$p(X = 1) = p(Y = 1) = \frac{1}{4}$$

$$p(X = 2) = p(Y = 2) = \frac{1}{4}$$

Let

$$X + Y = 2 \rightarrow A$$

and

$$X - Y = 0 \rightarrow B$$

Now

$$P(X + Y = 2 | X - Y = 0) = \frac{P(A \cap B)}{P(B)}$$

Event  $P(A \cap B)$  happen when  $X + Y = 2$  and  $X - Y = 0$ . It is only the case when  $X = 1$  and  $Y = 1$ .

Thus 
$$P(A \cap B) = \frac{1}{4} \times \frac{1}{4} = \frac{1}{16}$$

Now event  $P(B)$  happen when

$X - Y = 0$  It occurs when  $X = Y$ , i.e.

$X = 0$  and  $Y = 0$  or

$X = 1$  and  $Y = 1$  or

$X = 2$  and  $Y = 2$

Thus 
$$P(B) = \frac{1}{2} \times \frac{1}{2} + \frac{1}{4} \times \frac{1}{4} + \frac{1}{4} \times \frac{1}{4} = \frac{6}{16}$$

Now 
$$\frac{P(A \cap B)}{P(B)} = \frac{1/16}{6/16} = \frac{1}{6}$$

- MCQ 1.22** The Taylor series expansion of  $\frac{\sin x}{x - \pi}$  at  $x = \pi$  is given by

(A)  $1 + \frac{(x - \pi)^2}{3!} + \dots$  (B)  $-1 - \frac{(x - \pi)^2}{3!} + \dots$

$$(C) 1 - \frac{(x - \pi)^2}{3!} + \dots \qquad (D) -1 + \frac{(x - \pi)^2}{3!} + \dots$$

**SOL 1.22** Hence (D) is correct answer.

$$\text{We have } f(x) = \frac{\sin x}{x - \pi}$$

Substituting  $x - \pi = y$ , we get

$$\begin{aligned} f(y + \pi) &= \frac{\sin(y + \pi)}{y} = -\frac{\sin y}{y} = -\frac{1}{y}(\sin y) \\ &= -\frac{1}{y} \left( y - \frac{y^3}{3!} + \frac{y^5}{5!} - \dots \right) \end{aligned}$$

$$\text{or } f(y + \pi) = -1 + \frac{y^2}{3!} - \frac{y^4}{5!} + \dots$$

Substituting  $x - \pi = y$  we get

$$f(x) = -1 + \frac{(x - \pi)^2}{3!} - \frac{(x - \pi)^4}{5!} + \dots$$

**MCQ 1.23**

If a vector field  $\vec{V}$  is related to another vector field  $\vec{A}$  through  $\vec{V} = \nabla \times \vec{A}$ , which of the following is true? (Note :  $C$  and  $S_C$  refer to any closed contour and any surface whose boundary is  $C$ .)

$$(A) \oint_C \vec{V} \cdot d\vec{l} = \int_S \int_C \vec{A} \cdot d\vec{S} \qquad (B) \oint_C \vec{A} \cdot d\vec{l} = \int_S \int_C \vec{V} \cdot d\vec{S}$$

$$(C) \oint_C \Delta \times \vec{V} \cdot d\vec{l} = \int_S \int_C \Delta \times \vec{A} \cdot d\vec{S} \qquad (D) \oint_C \Delta \times \vec{V} \cdot d\vec{l} = \int_S \int_C \vec{V} \cdot d\vec{S}$$

**SOL 1.23**

Hence (B) is correct option.

$$\text{We have } \qquad \qquad \qquad V = \nabla \times A \qquad \dots(1)$$

By Stokes theorem

$$\oint A \cdot dl = \iint (\nabla \times A) \cdot ds \qquad \dots(2)$$

From (1) and (2) we get

$$\oint A \cdot dl = \iint V \cdot ds$$

**MCQ 1.24**

Given that  $F(s)$  is the one-side Laplace transform of  $f(t)$ , the Laplace transform of  $\int_0^t f(\tau) d\tau$  is

$$(A) sF(s) - f(0) \qquad (B) \frac{1}{s}F(s)$$

$$(C) \int_0^s F(\tau) d\tau \qquad (D) \frac{1}{s}[F(s) - f(0)]$$

**SOL 1.24**

By property of unilateral laplace transform

$$\int_{-\infty}^t f(\tau) d\tau \xrightarrow{L} \frac{F(s)}{s} + \frac{1}{s} \int_{-\infty}^0 f(\tau) d\tau$$

Here function is defined for  $0 < \tau < t$ , Thus

$$\int_0^t f(\tau) d\tau \xrightarrow{L} \frac{F(s)}{s}$$

Hence (B) is correct answer.

**MCQ 1.25** Match each differential equation in Group I to its family of solution curves from Group II

Group I

Group II

A.  $\frac{dy}{dx} = \frac{y}{x}$

1. Circles

B.  $\frac{dy}{dx} = -\frac{y}{x}$

2. Straight lines

C.  $\frac{dy}{dx} = \frac{x}{y}$

3. Hyperbolas

D.  $\frac{dy}{dx} = -\frac{x}{y}$

(A) A – 2, B – 3, C – 3, D – 1

(B) A – 1, B – 3, C – 2, D – 1

(C) A – 2, B – 1, C – 3, D – 3

(D) A – 3, B – 2, C – 1, D – 2

**SOL 1.25** Hence (A) is correct answer

(A)  $\frac{dy}{dx} = \frac{y}{x}$

or  $\int \frac{dy}{y} = \int \frac{dx}{x}$

or  $\log y = \log x + \log c$

or  $y = cx$  Straight Line

Thus option (A) and (C) may be correct.

(B)  $\frac{dy}{dx} = -\frac{y}{x}$

or  $\int \frac{dy}{y} = -\int \frac{dx}{x}$

or  $\log y = -\log x + \log c$

or  $\log y = \log \frac{1}{x} + \log c$

or  $y = \frac{c}{x}$  Hyperbola

**MCQ 1.26** The Eigen values of following matrix are

(A)  $3, 3 + 5j, 6 - j$

(B)  $-6 + 5j, 3 + j, 3 - j$

(C)  $3 + j, 3 - j, 5 + j$

(D)  $3, -1 + 3j, -1 - 3j$

**SOL 1.26**

Sum of the principal diagonal element of matrix is equal to the sum of Eigen values. Sum of the diagonal element is  $-1 - 1 + 3 = 1$ . In only option (D), the sum of Eigen values is 1.

Hence (D) is correct answer.

**MCQ 1.27**

An AC source of RMS voltage  $20\text{ V}$  with internal impedance  $Z_s = (1 + 2j)\Omega$  feeds a load of impedance  $Z_L = (7 + 4j)\Omega$  in the figure below. The reactive power consumed by the load is

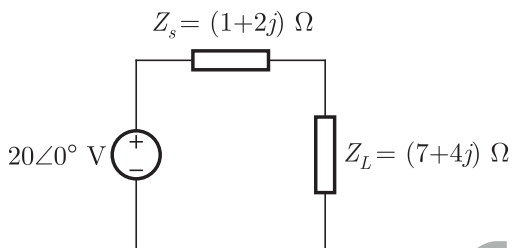

(A) 8 VAR

(B) 16 VAR

(C) 28 VAR

(D) 32 VAR

**SOL 1.27**

From given circuit the load current is

$$I_L = \frac{V}{Z_s + Z_L} = \frac{20\angle 0^\circ}{(1 + 2j) + (7 + 4j)} = \frac{20\angle 0^\circ}{8 + 6j}$$

$$= \frac{1}{5}(8 - 6j) = \frac{20\angle 0^\circ}{10\angle \phi} = 2\angle -\phi \quad \text{where } \phi = \tan^{-1} \frac{3}{4}$$

The voltage across load is

$$V_L = I_L Z_L$$

The reactive power consumed by load is

$$P_r = V_L I_L^* = I_L Z_L \times I_L^* = Z_L |I_L|^2$$

$$= (7 + 4j) \left| \frac{20\angle 0^\circ}{8 + 6j} \right|^2 = (7 + 4j) = 28 + 16j$$

Thus average power is 28 and reactive power is 16.

Hence (B) is correct option.

**MCQ 1.28**

The switch in the circuit shown was on position a for a long time, and is move to position b at time  $t = 0$ . The current  $i(t)$  for  $t > 0$  is given by

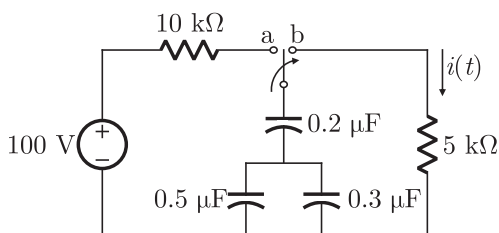

- (A)  $0.2e^{-125t} u(t)$  mA                      (B)  $20e^{-1250t} u(t)$  mA  
 (C)  $0.2e^{-1250t} u(t)$  mA                      (D)  $20e^{-1000t} u(t)$  mA

**SOL 1.28** At  $t = 0^-$ , the circuit is as shown in fig below :

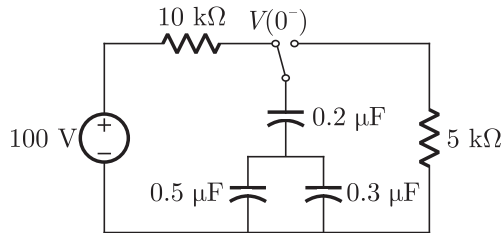

$$V(0^-) = 100 \text{ V}$$

Thus

$$V(0^+) = 100 \text{ V}$$

At  $t = 0^+$ , the circuit is as shown below

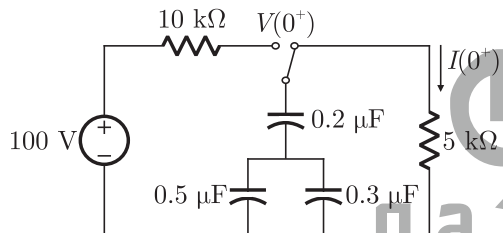

$$I(0^+) = \frac{100}{5k} = 20 \text{ mA}$$

At steady state i.e. at  $t = \infty$  is  $I(\infty) = 0$

Now  $i(t) = I(0^+) e^{-\frac{t}{RC_{eq}}} u(t)$

$$C_{eq} = \frac{(0.5\mu + 0.3\mu)0.2\mu}{0.5\mu + 0.3\mu + 0.2\mu} = 0.16 \mu\text{F}$$

$$\frac{1}{RC_{eq}} = \frac{1}{5 \times 10^3 \times 0.16 \times 10^{-6}} = 1250$$

$$i(t) = 20e^{-1250t} u(t) \text{ mA}$$

Hence (B) is correct option.

**MCQ 1.29** In the circuit shown, what value of  $R_L$  maximizes the power delivered to  $R_L$ ?

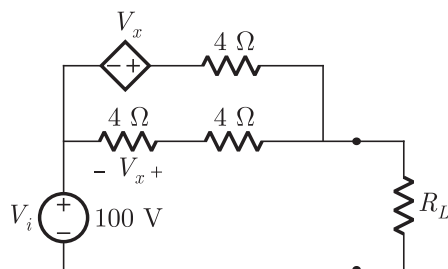

(A)  $2.4 \Omega$

(B)  $\frac{8}{3} \Omega$

(C)  $4 \Omega$ (D)  $6 \Omega$ **SOL 1.29**

For  $P_{\max}$  the load resistance  $R_L$  must be equal to thevenin resistance  $R_{eq}$  i.e.  $R_L = R_{eq}$ . The open circuit and short circuit is as shown below

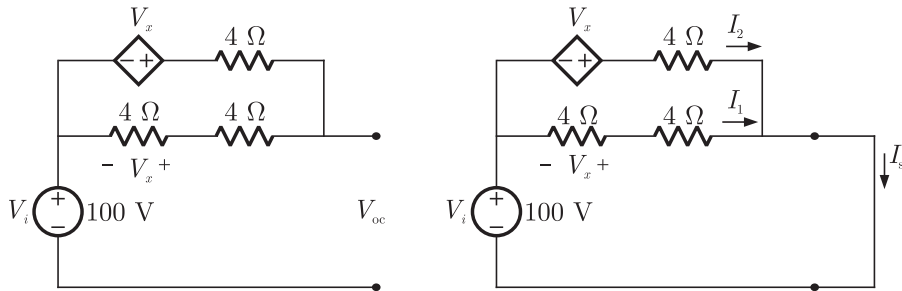

The open circuit voltage is

$$V_{oc} = 100 \text{ V}$$

From fig

$$I_1 = \frac{100}{8} = 12.5 \text{ A}$$

$$V_x = -4 \times 12.5 = -50 \text{ V}$$

$$I_2 = \frac{100 + V_x}{4} = \frac{100 - 50}{4} = 12.5 \text{ A}$$

$$I_{sc} = I_1 + I_2 = 25 \text{ A}$$

$$R_{th} = \frac{V_{oc}}{I_{sc}} = \frac{100}{25} = 4 \Omega$$

Thus for maximum power transfer  $R_L = R_{eq} = 4 \Omega$

Hence (C) is correct option.

**MCQ 1.30**

The time domain behavior of an  $RL$  circuit is represented by

$$L \frac{di}{dt} + Ri = V_0(1 + Be^{-Rt/L} \sin t) u(t).$$

For an initial current of  $i(0) = \frac{V_0}{R}$ , the steady state value of the current is given by

(A)  $i(t) \rightarrow \frac{V_0}{R}$

(B)  $i(t) \rightarrow \frac{2V_0}{R}$

(C)  $i(t) \rightarrow \frac{V_0}{R}(1 + B)$

(D)  $i(t) \rightarrow \frac{2V_0}{R}(1 + B)$

**SOL 1.30**

Steady state all transient effect die out and inductor act as short circuits and forced response acts only. It doesn't depend on initial current state. From the given time domain behavior we get that circuit has only  $R$  and  $L$  in series with  $V_0$ . Thus at steady state

$$i(t) \rightarrow i(\infty) = \frac{V_0}{R}$$

Hence (A) is correct option.

**MCQ 1.31** In the circuit below, the diode is ideal. The voltage  $V$  is given by

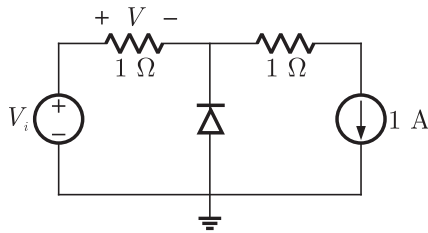

- (A)  $\min(V_i, 1)$  (B)  $\max(V_i, 1)$   
 (C)  $\min(-V_i, 1)$  (D)  $\max(-V_i, 1)$

**SOL 1.31** Let diode be OFF. In this case 1 A current will flow in resistor and voltage across resistor will be  $V = 1V$

Diode is off, it must be in reverse biased, therefore

$$V_i - 1 > 0 \rightarrow V_i > 1$$

Thus for  $V_i > 1$  diode is off and  $V = 1V$

Option (B) and (C) doesn't satisfy this condition.

Let  $V_i < 1$ . In this case diode will be on and voltage across diode will be zero and  $V = V_i$

Thus  $V = \min(V_i, 1)$

Hence (A) is correct option.

**MCQ 1.32** Consider the following two statements about the internal conditions in a  $n$ -channel MOSFET operating in the active region.

S1 : The inversion charge decreases from source to drain

S2 : The channel potential increases from source to drain.

Which of the following is correct?

- (A) Only S2 is true  
 (B) Both S1 and S2 are false  
 (C) Both S1 and S2 are true, but S2 is not a reason for S1  
 (D) Both S1 and S2 are true, and S2 is a reason for S1

**SOL 1.32** Both S1 and S2 are true and S2 is a reason for S1.

Hence option (D) is correct.

**MCQ 1.33** In the following a stable multivibrator circuit, which properties of  $v_0(t)$  depend on  $R_2$ ?

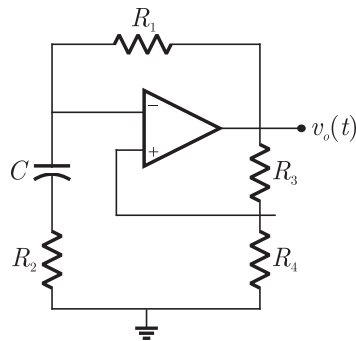

- (A) Only the frequency
- (B) Only the amplitude
- (C) Both the amplitude and the frequency
- (D) Neither the amplitude nor the frequency

**SOL 1.33** The  $R_2$  decide only the frequency.  
Hence (A) is correct option

**MCQ 1.34** In the circuit shown below, the op-amp is ideal, the transistor has  $V_{BE} = 0.6 \text{ V}$  and  $\beta = 150$ . Decide whether the feedback in the circuit is positive or negative and determine the voltage  $V$  at the output of the op-amp.

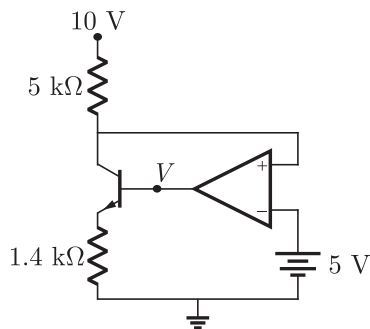

- (A) Positive feedback,  $V = 10 \text{ V}$ .
- (B) Positive feedback,  $V = 0 \text{ V}$
- (C) Negative feedback,  $V = 5 \text{ V}$
- (D) Negative feedback,  $V = 2 \text{ V}$

**SOL 1.34** The circuit is shown in fig below

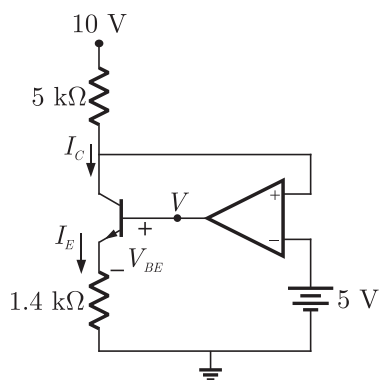



The voltage at non inverting terminal is 5 V because OP AMP is ideal and inverting terminal is at 5 V.

$$\text{Thus } I_C = \frac{10 - 5}{5k} = 1 \text{ mA}$$

$$\begin{aligned} V_E = I_E R_E &= 1m \times 1.4k = 1.4 \text{ V} & I_E = I_C \\ &= 0.6 + 1.4 = 2 \text{ V} \end{aligned}$$

Thus the feedback is negative and output voltage is  $V = 2 \text{ V}$ .

Hence (D) is correct option.

**MCQ 1.35**

A small signal source  $V_i(t) = A \cos 20t + B \sin 10^6 t$  is applied to a transistor amplifier as shown below. The transistor has  $\beta = 150$  and  $h_{ie} = 3\Omega$ . Which expression best approximate  $V_0(t)$

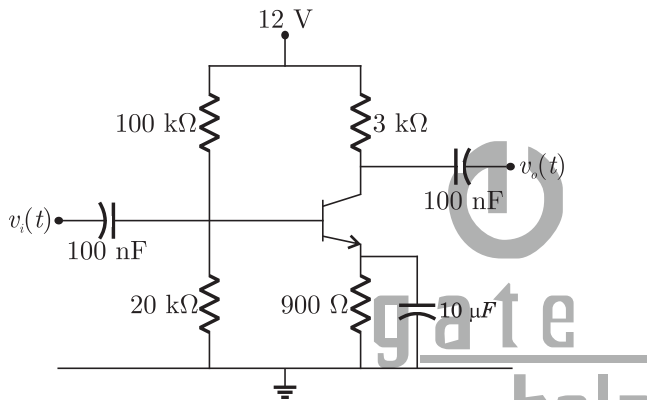

- (A)  $V_0(t) = -1500(A \cos 20t + B \sin 10^6 t)$   
 (B)  $V_0(t) = -1500(A \cos 20t + B \sin 10^6 t)$   
 (C)  $V_0(t) = -1500B \sin 10^6 t$   
 (D)  $V_0(t) = -150B \sin 10^6 t$

**SOL 1.35**

The output voltage is

$$V_0 = A_r V_i \approx -\frac{h_{fe} R_C}{h_{ie}} V_i$$

Here  $R_C = 3\Omega$  and  $h_{ie} = 3k\Omega$

$$\text{Thus } V_0 \approx -\frac{150 \times 3k}{3k} V_i$$

$$\approx -150(A \cos 20t + B \sin 10^6 t)$$

Since coupling capacitor is large so low frequency signal will be filtered out, and best approximation is

$$V_0 \approx -150B \sin 10^6 t$$

Hence (D) is correct option.

**MCQ 1.36**

If  $X = 1$  in logic equation  $[X + Z\{\bar{Y} + (\bar{Z} + X\bar{Y})\}]\{\bar{X} + \bar{X}(X + Y)\} = 1$ , then

- (A)  $Y = Z$  (B)  $Y = \bar{Z}$   
 (C)  $Z = 1$  (D)  $Z = 0$

**SOL 1.36** We have  $[X + Z\{\bar{Y} + (\bar{Z} + X\bar{Y})\}][\bar{X} + \bar{Z}(X + Y)] = 1$   
 Substituting  $X = 1$  and  $\bar{X} = 0$  we get  
 $[1 + Z\{\bar{Y} + (\bar{Z} + 1\bar{Y})\}][0 + \bar{Z}(1 + Y)] = 1$   
 or  $[1][\bar{Z}(1)] = 1$   $1 + A = 1$  and  $0 + A = A$   
 or  $\bar{Z} = 1 \leftrightarrow Z = 0$   
 Hence (D) is correct answer

**MCQ 1.37** What are the minimum number of 2- to -1 multiplexers required to generate a 2- input AND gate and a 2- input Ex-OR gate  
 (A) 1 and 2 (B) 1 and 3  
 (C) 1 and 1 (D) 2 and 2

**SOL 1.37** The AND gate implementation by 2:1 mux is as follows

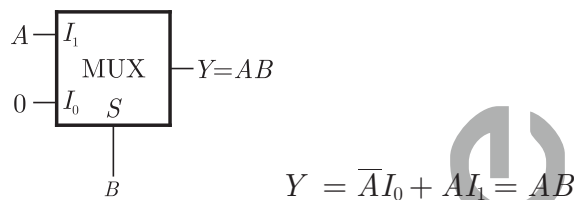

The EX – OR gate implementation by 2:1 mux is as follows

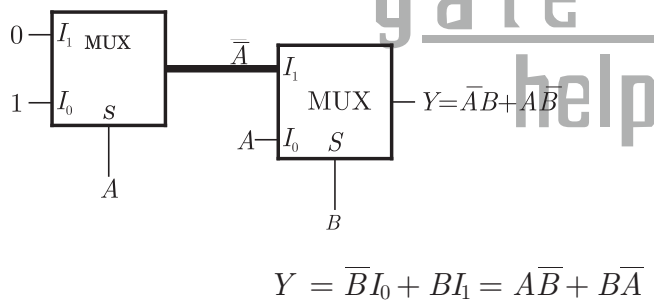

Hence (A) is correct answer.

**MCQ 1.38** Refer to the NAND and NOR latches shown in the figure. The inputs ( $P_1, P_2$ ) for both latches are first made (0, 1) and then, after a few seconds, made (1, 1). The corresponding stable outputs ( $Q_1, Q_2$ ) are

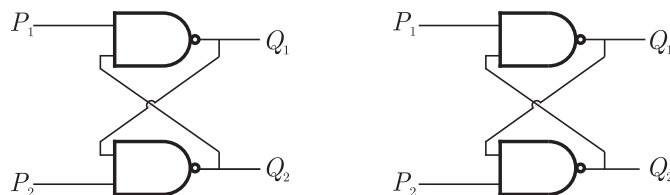

- (A) NAND: first (0, 1) then (0, 1) NOR: first (1, 0) then (0, 0)
- (B) NAND : first (1, 0) then (1, 0) NOR : first (1, 0) then (1, 0)
- (C) NAND : first (1, 0) then (1, 0) NOR : first (1, 0) then (0, 0)
- (D) NAND : first (1, 0) then (1, 1) NOR : first (0, 1) then (0, 1)

**SOL 1.38** For the NAND latch the stable states are as follows

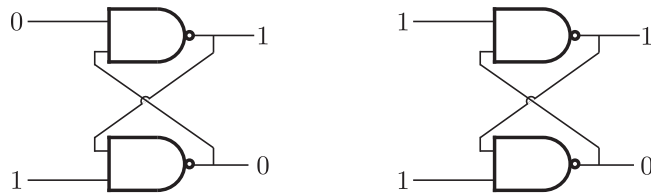

For the NOR latch the stable states are as follows

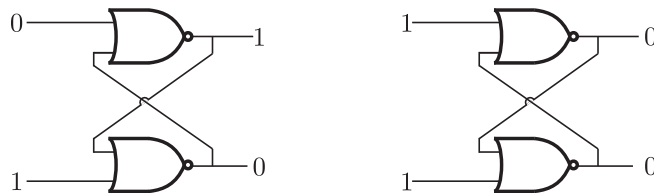

Hence (C) is correct answer.

**MCQ 1.39** What are the counting states ( $Q_1, Q_2$ ) for the counter shown in the figure below

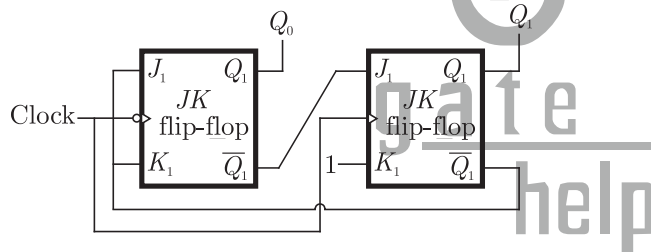

- (A) 11, 10, 00, 11, 10, ...
- (B) 01, 10, 11, 00, 01, ...
- (C) 00, 11, 01, 10, 00, ...
- (D) 01, 10, 00, 01, 10, ...

**SOL 1.39** The given circuit is as follows.

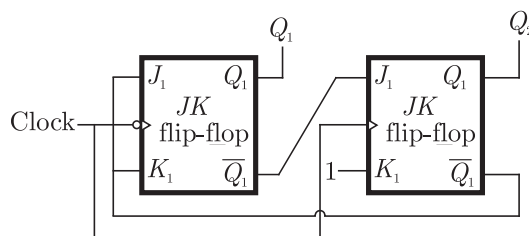

The truth table is as shown below. Sequence is 00, 11, 10, 00 ...

CLK	$J_1$	$K_1$	$Q_1$	$J_2$	$K_2$	$Q_2$
1	1	1	0	1	1	0
2	1	1	1	1	1	1
3	0	0	1	0	1	0
4	1	1	0	1	1	0

Hence (A) is correct answer.

**MCQ 1.40** A system with transfer function  $H(z)$  has impulse response  $h(\cdot)$  defined as  $h(2) = 1, h(3) = -1$  and  $h(k) = 0$  otherwise. Consider the following statements.

S1 :  $H(z)$  is a low-pass filter.

S2 :  $H(z)$  is an FIR filter.

Which of the following is correct?

- (A) Only S2 is true  
 (B) Both S1 and S2 are false  
 (C) Both S1 and S2 are true, and S2 is a reason for S1  
 (D) Both S1 and S2 are true, but S2 is not a reason for S1

**SOL 1.40** We have  $h(2) = 1, h(3) = -1$  otherwise  $h(k) = 0$ . The diagram of response is as follows :

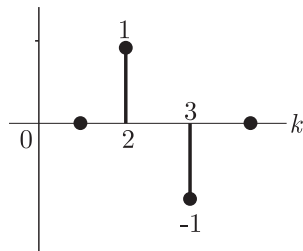

It has the finite magnitude values. So it is a finite impulse response filter. Thus  $S_2$  is true but it is not a low pass filter. So  $S_1$  is false.

Hence (A) is correct answer.

**MCQ 1.41** Consider a system whose input  $x$  and output  $y$  are related by the equation  $y(t) = \int_{-\infty}^{\infty} x(t-\tau)g(2\tau) d\tau$  where  $h(t)$  is shown in the graph.

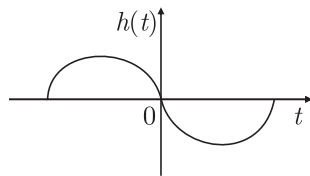

Which of the following four properties are possessed by the system ?

BIBO : Bounded input gives a bounded output.

Causal : The system is causal,

LP : The system is low pass.

LTI : The system is linear and time-invariant.

- (A) Causal, LP (B) BIBO, LTI  
 (C) BIBO, Causal, LTI (D) LP, LTI

**SOL 1.41** Here  $h(t) \neq 0$  for  $t < 0$ . Thus system is non causal. Again any bounded input  $x(t)$  gives bounded output  $y(t)$ . Thus it is BIBO stable.

Here we can conclude that option (B) is correct.

Hence (B) is correct answer.

**MCQ 1.42** The 4-point Discrete Fourier Transform (DFT) of a discrete time sequence  $\{1,0,2,3\}$  is

- (A)  $[0, -2 + 2j, 2, -2 - 2j]$  (B)  $[2, 2 + 2j, 6, 2 - 2j]$   
 (C)  $[6, 1 - 3j, 2, 1 + 3j]$  (D)  $[6, -1 + 3j, 0, -1 - 3j]$

**SOL 1.42** Hence (D) is correct answer

We have  $x[n] = \{1,0,2,3\}$  and  $N = 4$

$$X[k] = \sum_{n=0}^{N-1} x[n] e^{-j2\pi nk/N} \quad k = 0, 1, \dots, N-1$$

For  $N = 4$ , 
$$X[k] = \sum_{n=0}^3 x[n] e^{-j2\pi nk/4} \quad k = 0, 1, \dots, 3$$

Now 
$$X[0] = \sum_{n=0}^3 x[n]$$

$$= x[0] + x[1] + x[2] + x[3] = 1 + 0 + 2 + 3 = 6$$

$$X[1] = \sum_{n=0}^3 x[n] e^{-j\pi n/2}$$

$$= x[0] + x[1] e^{-j\pi/2} + x[2] e^{-j\pi} + x[3] e^{-j3\pi/2}$$

$$= 1 + 0 - 2 + j3 = -1 + j3$$

$$X[2] = \sum_{n=0}^3 x[n] e^{-j\pi n}$$

$$= x[0] + x[1] e^{-j\pi} + x[2] e^{-j2\pi} + x[3] e^{-j3\pi}$$

$$= 1 + 0 + 2 - 3 = 0$$

$$X[3] = \sum_{n=0}^3 x[n] e^{-j3\pi n/2}$$

$$= x[0] + x[1] e^{-j3\pi/2} + x[2] e^{-j3\pi} + x[3] e^{-j9\pi/2}$$

$$= 1 + 0 - 2 - j3 = -1 - j3$$

Thus  $[6, -1 + j3, 0, -1 - j3]$

**MCQ 1.43** The feedback configuration and the pole-zero locations of

$$G(s) = \frac{s^2 - 2s + 2}{s^2 + 2s + 2}$$

are shown below. The root locus for negative values of  $k$ , i.e. for  $-\infty < k < 0$ , has breakaway/break-in points and angle of departure at pole  $P$  (with respect to the positive real axis) equal to

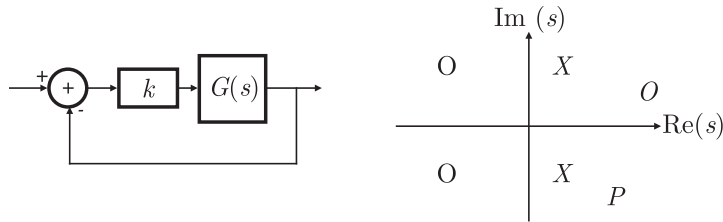

- (A)  $\pm\sqrt{2}$  and  $0^\circ$
- (B)  $\pm\sqrt{2}$  and  $45^\circ$
- (C)  $\pm\sqrt{3}$  and  $0^\circ$
- (D)  $\pm\sqrt{3}$  and  $45^\circ$

**SOL 1.43** The characteristic equation is

$$1 + G(s)H(s) = 0$$

$$\text{or } 1 + \frac{K(s^2 - 2s + 2)}{s^2 + 2s + 2} = 0$$

$$\text{or } s^2 + 2s + 2 + K(s^2 - 2s + 2) = 0$$

$$\text{or } K = -\frac{s^2 + 2s + 2}{s^2 - 2s + 2}$$

For break away & break in point differentiating above w.r.t.  $s$  we have

$$\frac{dK}{ds} = -\frac{(s^2 - 2s + 2)(2s + 2) - (s^2 + 2s + 2)(2s - 2)}{(s^2 - 2s + 2)^2} = 0$$

$$\text{Thus } (s^2 - 2s + 2)(2s + 2) - (s^2 + 2s + 2)(2s - 2) = 0$$

$$\text{or } s = \pm\sqrt{2}$$

Let  $\theta_d$  be the angle of departure at pole  $P$ , then

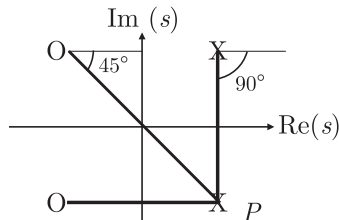

$$-\theta_d - \theta_{p1} + \theta_{z1} + \theta_{z2} = 180^\circ$$

$$-\theta_d = 180^\circ - (-\theta_{p1} + \theta_{z1} + \theta_{z2})$$

$$= 180^\circ - (90^\circ + 180 - 45^\circ) = -45^\circ$$

Hence (B) is correct option.

**MCQ 1.44** An LTI system having transfer function  $\frac{s^2+1}{s^2+2s+1}$  and input  $x(t) = \sin(t+1)$  is in steady state. The output is sampled at a rate  $\omega_s$  rad/s to obtain the final output  $\{x(k)\}$ . Which of the following is true ?

- (A)  $y(\cdot)$  is zero for all sampling frequencies  $\omega_s$
- (B)  $y(\cdot)$  is nonzero for all sampling frequencies  $\omega_s$
- (C)  $y(\cdot)$  is nonzero for  $\omega_s > 2$ , but zero for  $\omega_s < 2$
- (D)  $y(\cdot)$  is zero for  $\omega_s > 2$ , but nonzero for  $\omega_s < 2$

**SOL 1.44** Hence (A) is correct answer.

**MCQ 1.45** The unit step response of an under-damped second order system has steady state value of -2. Which one of the following transfer functions has these properties ?

- (A)  $\frac{-2.24}{s^2 + 2.59s + 1.12}$  (B)  $\frac{-3.82}{s^2 + 1.91s + 1.91}$   
 (C)  $\frac{-2.24}{s^2 - 2.59s + 1.12}$  (D)  $\frac{-382}{s^2 - 1.91s + 1.91}$

**SOL 1.45** For under-damped second order response

$$T(s) = \frac{k\omega_n^2}{s^2 + 2\xi\omega_n s + \omega_n^2} \quad \text{where } \xi < 1$$

Thus (A) or (B) may be correct

For option (A)  $\omega_n = 1.12$  and  $2\xi\omega_n = 2.59 \rightarrow \xi = 1.12$

For option (B)  $\omega_n = 1.91$  and  $2\xi\omega_n = 1.51 \rightarrow \xi = 0.69$

Hence (B) is correct option.

**MCQ 1.46** A discrete random variable  $X$  takes values from 1 to 5 with probabilities as shown in the table. A student calculates the mean  $X$  as 3.5 and her teacher calculates the variance of  $X$  as 1.5. Which of the following statements is true ?

$k$	1	2	3	4	5
$P(X = k)$	0.1	0.2	0.3	0.4	0.5

- (A) Both the student and the teacher are right  
 (B) Both the student and the teacher are wrong  
 (C) The student is wrong but the teacher is right  
 (D) The student is right but the teacher is wrong

**SOL 1.46** Hence (B) is correct option.

The mean is

$$\begin{aligned} \bar{X} &= \sum x_i p_i(x) \\ &= 1 \times 0.1 + 2 \times 0.2 + 3 \times 0.4 + 4 \times 0.2 + 5 \times 0.1 \\ &= 0.1 + 0.4 + 1.2 + 0.8 + 0.5 = 3.0 \end{aligned}$$

$$\begin{aligned} \overline{X^2} &= \sum x_i^2 p_i(x) \\ &= 1 \times 0.1 + 4 \times 0.2 + 9 \times 0.4 + 16 \times 0.2 + 25 \times 0.1 \\ &= 0.1 + 0.8 + 3.6 + 3.2 + 2.5 = 10.2 \end{aligned}$$

$$\begin{aligned} \text{Variance } \sigma_x^2 &= \overline{X^2} - (\bar{X})^2 \\ &= 10.2 - (3)^2 = 1.2 \end{aligned}$$

**MCQ 1.47** A message signal given by  $m(t) = (\frac{1}{2})\cos\omega_1 t - (\frac{1}{2})\sin\omega_2 t$  amplitude - modulated with a carrier of frequency  $\omega_c$  to generator  $s(t)[1 + m(t)]\cos\omega_c t$ . What is the power efficiency achieved by this modulation scheme ?

- (A) 8.33% (B) 11.11%  
 (C) 20% (D) 25%

**SOL 1.47** Hence (C) is correct option.

$$m(t) = \frac{1}{2} \cos \omega_1 t - \frac{1}{2} \sin \omega_2 t$$

$$s_{AM}(t) = [1 + m(t)] \cos \omega_c t$$

Modulation index

$$= \frac{|m(t)|_{\max}}{V_c}$$

$$m = \sqrt{\left(\frac{1}{2}\right)^2 + \left(\frac{1}{2}\right)^2} = \frac{1}{\sqrt{2}}$$

$$\eta = \frac{m^2}{m^2 + 2} \times 100\% = \frac{\left(\frac{1}{\sqrt{2}}\right)^2}{\left(\frac{1}{\sqrt{2}}\right)^2 + 2} \times 100\% = 20\%$$

**MCQ 1.48** A communication channel with AWGN operating at a signal to noise ratio  $SNR \gg 1$  and bandwidth  $B$  has capacity  $C_1$ . If the  $SNR$  is doubled keeping constant, the resulting capacity  $C_2$  is given by

(A)  $C_2 \approx 2C_1$

(B)  $C_2 \approx C_1 + B$

(C)  $C_2 \approx C_1 + 2B$

(D)  $C_2 \approx C_1 + 0.3B$

**SOL 1.48** Hence (B) is correct option.

We have  $C_1 = B \log_2 \left(1 + \frac{S}{N}\right)$

$$\approx B \log_2 \left(\frac{S}{N}\right)$$

As  $\frac{S}{N} \gg 1$

If we double the  $\frac{S}{N}$  ratio then

$$C_2 \approx B \log_2 \left(\frac{2S}{N}\right)$$

$$\approx B \log_2 2 + B \log_2 \frac{S}{N}$$

$$\approx B + C_1$$

**MCQ 1.49** A magnetic field in air is measured to be

$$\vec{B} = B_0 \left( \frac{x}{x^2 + y^2} \hat{y} - \frac{y}{x^2 + y^2} \hat{x} \right)$$

What current distribution leads to this field ?

[Hint : The algebra is trivial in cylindrical coordinates.]

(A)  $\vec{J} = \frac{B_0 \hat{z}}{\mu_0} \left( \frac{1}{x^2 + y^2} \right), r \neq 0$

(B)  $\vec{J} = -\frac{B_0 \hat{z}}{\mu_0} \left( \frac{2}{x^2 + y^2} \right), r \neq 0$

(C)  $\vec{J} = 0, r \neq 0$

(D)  $\vec{J} = \frac{B_0 \hat{z}}{\mu_0} \left( \frac{1}{x^2 + y^2} \right), r \neq 0$

**SOL 1.49** Hence (C) is correct option.

We have  $\vec{B} = B_0 \left( \frac{x}{x^2 + y^2} a_y - \frac{y}{x^2 + y^2} a_x \right) \dots(1)$

To convert in cylindrical substituting



$$x = r \cos \phi \text{ and } y = r \sin \phi$$

$$a_x = \cos \phi a_r - \sin \phi a_\phi$$

and  $a_y = \sin \phi a_r + \cos \phi a_\phi$

In (1) we have

$$\vec{B} = \vec{B}_0 a_\phi$$

Now  $\vec{H} = \frac{\vec{B}}{\mu_0} = \frac{\vec{B}_0 a_\phi}{\mu_0}$

constant

$$\vec{J} = \nabla \times \vec{H} = 0$$

since  $H$  is constant

**MCQ 1.50**

A transmission line terminates in two branches, each of length  $\frac{\lambda}{4}$ , as shown. The branches are terminated by  $50\Omega$  loads. The lines are lossless and have the characteristic impedances shown. Determine the impedance  $Z_i$  as seen by the source.

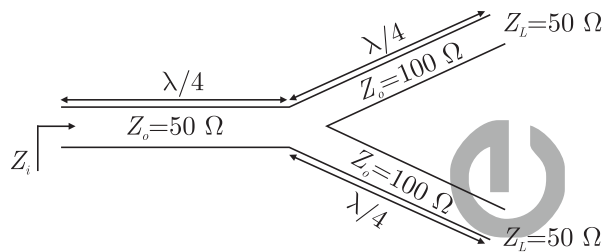

(A)  $200\Omega$

(B)  $100\Omega$

(C)  $50\Omega$

(D)  $25\Omega$

**SOL 1.50**

The transmission line are as shown below. Length of all line is  $\frac{\lambda}{4}$

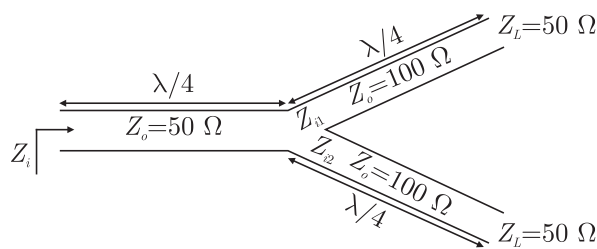

$$Z_{i1} = \frac{Z_{01}^2}{Z_{L1}} = \frac{100^2}{50} = 200\Omega$$

$$Z_{i2} = \frac{Z_{02}^2}{Z_{L2}} = \frac{100^2}{50} = 200\Omega$$

$$Z_{L3} = Z_{i1} \parallel Z_{i2} = 200\Omega \parallel 200\Omega = 100\Omega$$

$$Z_i = \frac{Z_0^2}{Z_{L3}} = \frac{50^2}{100} = 25\Omega$$

Hence (D) is correct option.

**Common Date for Question 51 and 52 :**

Consider a silicon  $p-n$  junction at room temperature having the following parameters:

Doping on the  $n$ -side =  $1 \times 10^{17} \text{ cm}^{-3}$

Depletion width on the  $n$ -side =  $0.1 \mu\text{m}$

Depletion width on the  $p$ -side =  $1.0 \mu\text{m}$

Intrinsic carrier concentration =  $1.4 \times 10^{10} \text{ cm}^{-3}$

Thermal voltage = 26 mV

Permittivity of free space =  $8.85 \times 10^{-14} \text{ F.cm}^{-1}$

Dielectric constant of silicon = 12

**MCQ 1.51** The built-in potential of the junction

(A) is 0.70 V

(B) is 0.76 V

(C) is 0.82 V

(D) Cannot be estimated from the data given

**SOL 1.51** Hence option (B) is correct.

We know that

$$N_A W_P = N_D W_N$$

$$\text{or } N_A = \frac{N_D W_N}{W_P} = \frac{1 \times 10^{17} \times 0.1 \times 10^{-6}}{1 \times 10^{-6}} = 1 \times 10^{16}$$

The built-in potential is

$$\begin{aligned} V_{bi} &= V_T \ln\left(\frac{N_A N_D}{n_i^2}\right) \\ &= 26 \times 10^{-3} \ln\left(\frac{1 \times 10^{17} \times 1 \times 10^{16}}{(1.4 \times 10^{10})^2}\right) = 0.760 \end{aligned}$$

**MCQ 1.52** The peak electric field in the device is

(A) 0.15 MV .  $\text{cm}^{-1}$ , directed from  $p$ -region to  $n$ -region

(B) 0.15 MV .  $\text{cm}^{-1}$ , directed from  $n$ -region to  $p$ -region

(C) 1.80 MV .  $\text{cm}^{-1}$ , directed from  $p$ -region to  $n$ -region

(D) 1.80 MV .  $\text{cm}^{-1}$ , directed from  $n$ -region to  $p$ -region

**SOL 1.52** The peak electric field in device is directed from  $p$  to  $n$  and is

$$\begin{aligned} E &= -\frac{eN_D x_n}{\epsilon_s} && \text{from } p \text{ to } n \\ &= \frac{eN_D x_n}{\epsilon_s} && \text{from } n \text{ to } p \\ &= \frac{1.6 \times 10^{-19} \times 1 \times 10^{17} \times 1 \times 10^{-5}}{8.85 \times 10^{-14} \times 12} = 0.15 \text{ MV/cm} \end{aligned}$$

Hence option (B) is correct.

### Common Data for Questions 53 and 54 :

The Nyquist plot of a stable transfer function  $G(s)$  is shown in the figure are interested in the stability of the closed loop system in the feedback configuration shown.

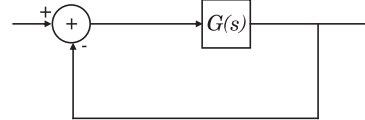
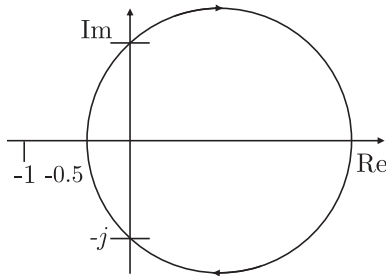

- MCQ 1.53** Which of the following statements is true ?
- (A)  $G(s)$  is an all-pass filter
  - (B)  $G(s)$  has a zero in the right-half plane
  - (C)  $G(s)$  is the impedance of a passive network
  - (D)  $G(s)$  is marginally stable

**SOL 1.53** The plot has one encirclement of origin in clockwise direction. Thus  $G(s)$  has a zero in RHP.  
Hence (B) is correct option.

- MCQ 1.54** The gain and phase margins of  $G(s)$  for closed loop stability are
- (A) 6 dB and  $180^\circ$
  - (B) 3 dB and  $180^\circ$
  - (C) 6 dB and  $90^\circ$
  - (D) 3 dB and  $90^\circ$

**SOL 1.54** The Nyquist plot intersect the real axis at  $-0.5$ . Thus  

$$G. M. = -20 \log x = -20 \log 0.5 = 6.020 \text{ dB}$$
 And its phase margin is  $90^\circ$ .  
Hence (C) is correct option.

### Common data for Questions 55 & 56 :

The amplitude of a random signal is uniformly distributed between  $-5 \text{ V}$  and  $5 \text{ V}$ .

- MCQ 1.55** If the signal to quantization noise ratio required in uniformly quantizing the signal is  $43.5 \text{ dB}$ , the step of the quantization is approximately
- (A)  $0.033 \text{ V}$
  - (B)  $0.05 \text{ V}$
  - (C)  $0.0667 \text{ V}$
  - (D)  $0.10 \text{ V}$

**SOL 1.55** Hence (C) is correct option.  
We have  $SNR = 1.76 + 6n$

$$\begin{aligned} \text{or } 43.5 &= 1.76 + 6n \\ 6n &= 43.5 + 1.76 \\ 6n &= 41.74 \rightarrow n \approx 7 \end{aligned}$$

No. of quantization level is

$$2^7 = 128$$

Step size required is

$$\begin{aligned} &= \frac{V_H - V_L}{128} = \frac{5 - (-5)}{128} = \frac{10}{128} \\ &= .078125 \\ &\approx .0667 \end{aligned}$$

- MCQ 1.56** If the positive values of the signal are uniformly quantized with a step size of 0.05 V, and the negative values are uniformly quantized with a step size of 0.1 V, the resulting signal to quantization noise ratio is approximately
- (A) 46 dB (B) 43.8 dB  
(C) 42 dB (D) 40 dB

**SOL 1.56** For positive values step size

$$s_+ = 0.05 \text{ V}$$

For negative value step size

$$s_- = 0.1 \text{ V}$$

No. of quantization in *+*ive is

$$= \frac{5}{s_+} = \frac{5}{0.05} = 100$$

Thus  $2^{n^+} = 100 \rightarrow n^+ = 7$

No. of quantization in *-*ive

$$Q_1 = \frac{5}{s_-} = \frac{5}{0.1} = 50$$

Thus  $2^{n^-} = 50 \rightarrow n^- = 6$

$$\left(\frac{S}{N}\right)_+ = 1.76 + 6n^+ = 1.76 + 42 = 43.76 \text{ dB}$$

$$\left(\frac{S}{N}\right)_- = 1.76 + 6n^- = 1.76 + 36 = 37.76 \text{ dB}$$

Best  $\left(\frac{S}{N}\right)_0 = 43.76 \text{ dB}$

Hence (B) is correct option.

**Statement for Linked Answer Question 57 and 58 :**

Consider for CMOS circuit shown, where the gate voltage  $v_0$  of the n-MOSFET is increased from zero, while the gate voltage of the p-MOSFET is kept constant at 3 V. Assume, that, for both transistors, the magnitude of the threshold voltage is 1 V and the product of the trans-conductance parameter is  $1\text{mA} \cdot \text{V}^{-2}$

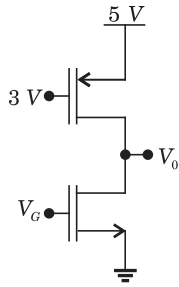

**MCQ 1.57** For small increase in  $V_G$  beyond 1V, which of the following gives the correct description of the region of operation of each MOSFET

- (A) Both the MOSFETs are in saturation region
- (B) Both the MOSFETs are in triode region
- (C) n-MOSFETs is in triode and  $p$ -MOSFET is in saturation region
- (D) n- MOSFET is in saturation and  $p$ -MOSFET is in triode region

**SOL 1.57** For small increase in  $V_G$  beyond 1 V the  $n$ - channel MOSFET goes into saturation as  $V_{GS} \rightarrow +ive$  and  $p$ - MOSFET is always in active region or triode region. Hence (D) is correct option.

**MCQ 1.58** Estimate the output voltage  $V_0$  for  $V_G = 1.5$  V. [Hints : Use the appropriate current-voltage equation for each MOSFET, based on the answer to Q.57]

- (A)  $4 - \frac{1}{\sqrt{2}}$
- (B)  $4 + \frac{1}{\sqrt{2}}$
- (C)  $4 - \frac{\sqrt{3}}{2}$
- (D)  $4 + \frac{\sqrt{3}}{2}$

**SOL 1.58** Hence (C) is correct option.

### Statement for Linked Answer Question 59 & 60 :

Two products are sold from a vending machine, which has two push buttons  $P_1$  and  $P_2$ .

When a buttons is pressed, the price of the corresponding product is displayed in a 7 - segment display. If no buttons are pressed, '0' is displayed signifying 'Rs 0'.

If only  $P_1$  is pressed, '2' is displayed, signifying 'Rs. 2'

If only  $P_2$  is pressed '5' is displayed, signifying 'Rs. 5'

If both  $P_1$  and  $P_2$  are pressed, 'E' is displayed, signifying 'Error'

The names of the segments in the 7 - segment display, and the glow of the display for '0', '2', '5' and 'E' are shown below.

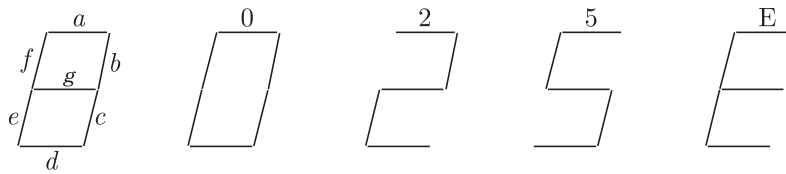

Consider

- (1) push buttons pressed/not pressed in equivalent to logic 1/0 respectively.
- (2) a segment glowing/not glowing in the display is equivalent to logic 1/0 respectively.

**MCQ 1.59** If segments  $a$  to  $g$  are considered as functions of  $P_1$  and  $P_2$ , then which of the following is correct

- (A)  $g = \overline{P_1} + P_2$ ,  $d = c + e$                       (B)  $g = P_1 + P_2$ ,  $d = c + e$   
 (C)  $g = \overline{P_1} + P_2$ ,  $e = b + c$                       (D)  $g = P_1 + P_2$ ,  $e = b + c$

**SOL 1.59** The given situation is as follows

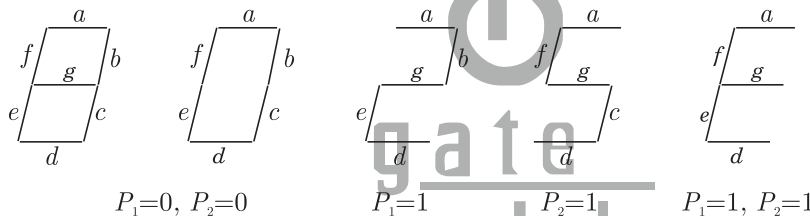

The truth table is as shown below

$P_1$	$P_2$	$a$	$b$	$c$	$d$	$e$	$f$	$g$
0	0	1	1	1	1	1	1	0
0	1	1	0	1	1	0	1	1
1	0	1	1	0	1	1	0	1
1	1	1	0	0	1	1	1	1

From truth table we can write

$$a = 1$$

$$b = \overline{P_1} \overline{P_2} + P_1 \overline{P_2} = \overline{P_2}$$

1 NOT Gate

$$c = \overline{P_1} \overline{P_2} + \overline{P_1} P_2 = \overline{P_1}$$

1 NOT Gate

$$d = 1 = c + e$$

and

$$e = \overline{P_1} P_2 = P_1 + \overline{P_2}$$

1 OR GATE

$$f = \overline{P_1} P_2 = \overline{P_1} + P_2$$

1 OR GATE

$$g = \overline{P_1} \overline{P_2} = P_1 + P_2$$

1 OR GATE

Thus we have  $g = P_1 + P_2$  and  $d = 1 = c + e$ . It may be observed easily from figure that

Led  $g$  does not glow only when both  $P_1$  and  $P_2$  are 0. Thus

$$g = P_1 + P_2$$

LED  $d$  is 1 all condition and also it depends on

$$d = c + e$$

Hence (B) is correct answer.

- MCQ 1.60** What are the minimum numbers of NOT gates and 2 - input OR gates required to design the logic of the driver for this 7 - Segment display
- (A) 3 NOT and 4 OR (B) 2 NOT and 4 OR  
(C) 1 NOT and 3 OR (D) 2 NOT and 3 OR

- SOL 1.60** As shown in previous solution 2 NOT gates and 3-OR gates are required.  
Hence (D) is correct answer.

Answer Sheet									
1.	(B)	13.	(C)	25.	(A)	37.	(A)	49.	(C)
2.	(A)	14.	(A)	26.	(D)	38.	(C)	50.	(D)
3.	(B)	15.	(A)	27.	(B)	39.	(A)	51.	(B)
4.	(C)	16.	(D)	28.	(B)	40.	(A)	52.	(B)
5.	(C)	17.	(C)	29.	(C)	41.	(B)	53.	(B)
6.	(C)	18.	(C)	30.	(A)	42.	(D)	54.	(C)
7.	(A)	19.	(C)	31.	(A)	43.	(B)	55.	(C)
8.	(C)	20.	(D)	32.	(D)	44.	(A)	56.	(B)
9.	(*)	21.	(C)	33.	(A)	45.	(B)	57.	(D)
10.	(A)	22.	(D)	34.	(D)	46.	(B)	58.	(C)
11.	(C)	23.	(B)	35.	(D)	47.	(C)	59.	(B)
12.	(*)	24.	(B)	36.	(D)	48.	(B)	60.	(D)

# Exclusive Series By Jhunjhunwala





## GATE CLOUD

By R. K . Kanodia & Ashish Murolia



**GATE Cloud** is an exclusive series of books which offers a completely solved question bank to GATE aspirants. The book of this series are featured as

- Over 1300 Multiple Choice Questions with full & detailed explanations.
- Questions are graded in the order of complexity from basic to advanced level.
- Contains all previous year GATE and IES exam questions from various branches
- Each question is designed to GATE exam level.
- Step by step methodology to solve problems

### Available Title In this series

-  Signals and Systems (For EC and EE)
-  Network Analysis (For EC)-- Available in 2 Volumes
-  Electric Circuit and Fields (For EE) -- Available in two volumes
-  Electromagnetic (For EC)

### Upcoming titles in this series

-  Digital Electronics (Nov 2012)
-  Control Systems (Dec 2012)
-  Communication Systems (Jan 2012)



# Exclusive Series By Jhunjhunwala

## GATE GUIDE



Theory, Example and Practice

By R. K . Kanodia & Ashish Murolia



**GATE GUIDE** is an exclusive series of books which provides theory, solved examples & practice exercises for preparing for GATE. A book of this series includes :

- **Brief and explicit theory**
- **Problem solving methodology**
- **Detailed explanations of examples**
- **Practice Exercises**

### Available Title In this series

-  **Signals and Systems (For EC and EE)**
-  **Network Analysis (For EC)**
-  **Electric Circuit and Fields (For EE)**

### Upcoming titles in this series

-  **Digital Electronics(For EC and EE)**
-  **Control Systems (For EC and EE)**
-  **Communication Systems (For EC and EE)**

