

2006

**PH : Physics**

Duration : Three Hours

Maximum Marks :150

**Read the following instructions carefully.**

1. This question paper contains all objective questions. Q.1 to Q.20 carry **one** mark each and Q.21 to Q.85 carry **two** marks each.
2. Answer all the questions.
3. Questions must be answered on **Objective Response Sheet (ORS)** by darkening the appropriate bubble (marked A, B, C, D) using HB pencil against the question number on the left hand side of the **ORS**. **Each question has only one correct answer**. In case you wish to change an answer, erase the old answer completely.
4. Wrong answers will carry **NEGATIVE** marks. In Q.1 to Q.20, **0.25** mark will be deducted for each wrong answer. In Q.21 to Q.76, Q.78, Q.80, Q.82 and in Q.84 **0.5** mark will be deducted for each wrong answer. However, there is no negative marking in Q.77, Q.79, Q.81, Q.83 and in Q.85. More than one answer bubbled against a question will be taken as an incorrect response.
5. Write your registration number, your name and name of the examination centre at the specified locations on the right half of the **ORS**.
6. Using HB pencil, darken the appropriate bubble under each digit of your registration number and the letters corresponding to your paper code.
7. Calculator is allowed in the examination hall.
8. Charts, graph sheets or tables are **NOT** allowed in the examination hall.
9. Rough work can be done on the question paper itself. Additionally blank pages are given at the end of the question paper for rough work.
10. This question paper contains **24** printed pages including pages for rough work. Please check all pages and report, if there is any discrepancy.

**Some useful physical constants and symbols**

Speed of light in free space	$c$	=	$3.0 \times 10^8 \text{ m s}^{-1}$
Atomic mass unit	amu	=	$1.66 \times 10^{-27} \text{ kg}$
Avagadro's number	$N_A$	=	$6.02 \times 10^{23} \text{ mole}^{-1}$
Boltzmann constant	$k_B$	=	$1.38 \times 10^{-23} \text{ J K}^{-1}$
Planck's constant	$h$	=	$6.63 \times 10^{-34} \text{ J s}$
Reduced Planck's constant ( $h/2\pi$ )	$\hbar$		
Permeability of free space	$\mu_0$		
Permittivity of free space	$\epsilon_0$		
Universal gas constant	$R$		

**Q. 1 – Q. 20 carry one mark each.**

- Q.1 The trace of a  $3 \times 3$  matrix is 2. Two of its eigenvalues are 1 and 2. The third eigenvalue is  
 (A) -1                      (B) 0                      (C) 1                      (D) 2
- Q.2 The value of  $\oint_C \vec{A} \cdot d\vec{\ell}$  along a square loop of side  $L$  in a uniform field  $\vec{A}$  is  
 (A) 0                      (B)  $2LA$                       (C)  $4LA$                       (D)  $L^2A$
- Q.3 A particle of charge  $q$ , mass  $m$  and linear momentum  $\vec{p}$  enters an electromagnetic field of vector potential  $\vec{A}$  and scalar potential  $\phi$ . The Hamiltonian of the particle is  
 (A)  $\frac{p^2}{2m} + q\phi + \frac{A^2}{2m}$                       (B)  $\frac{1}{2m} \left( \vec{p} - \frac{q}{c} \vec{A} \right)^2 + q\phi$   
 (C)  $\frac{1}{2m} \left( \vec{p} - \frac{q}{c} \vec{A} \right)^2 + \vec{p} \cdot \vec{A}$                       (D)  $\frac{p^2}{2m} q\phi - \vec{p} \cdot \vec{A}$
- Q.4 A particle is moving in an inverse square force field. If the total energy of the particle is positive, the trajectory of the particle is  
 (A) circular                      (B) elliptical                      (C) parabolic                      (D) hyperbolic
- Q.5 In an electromagnetic field, which one of the following remains invariant under Lorentz transformation?  
 (A)  $\vec{E} \times \vec{B}$                       (B)  $E^2 - c^2 B^2$                       (C)  $B^2$                       (D)  $E^2$

- Q.6 A sphere of radius  $R$  has uniform volume charge density. The electric potential at a point  $r$  ( $r < R$ ) is
- (A) due to the charge inside a sphere of radius  $r$  only  
 (B) due to the entire charge of the sphere  
 (C) due to the charge in the spherical shell of inner and outer radii  $r$  and  $R$ , only  
 (D) independent of  $r$
- Q.7 A free particle is moving in  $+x$  direction with a linear momentum  $p$ . The wavefunction of the particle normalised in a length  $L$  is
- (A)  $\frac{1}{\sqrt{L}} \sin \frac{p}{\hbar} x$     (B)  $\frac{1}{\sqrt{L}} \cos \frac{p}{\hbar} x$     (C)  $\frac{1}{\sqrt{L}} e^{-i\frac{p}{\hbar} x}$     (D)  $\frac{1}{\sqrt{L}} e^{i\frac{p}{\hbar} x}$
- Q.8 Which one of the following relations is true for Pauli matrices  $\sigma_x$ ,  $\sigma_y$  and  $\sigma_z$ ?
- (A)  $\sigma_x \sigma_y = \sigma_y \sigma_x$     (B)  $\sigma_x \sigma_y = \sigma_z$     (C)  $\sigma_x \sigma_y = i\sigma_z$     (D)  $\sigma_x \sigma_y = -\sigma_y \sigma_x$
- Q.9 The free energy of a photon gas enclosed in a volume  $V$  is given by  $F = -\frac{1}{3} aVT^4$ , where  $a$  is a constant and  $T$  is the temperature of the gas. The chemical potential of the photon gas is
- (A) 0    (B)  $\frac{4}{3} aVT^3$     (C)  $\frac{1}{3} aT^4$     (D)  $aVT^4$
- Q.10 The wavefunctions of two identical particles in states  $n$  and  $s$  are given by  $\phi_n(r_1)$  and  $\phi_s(r_2)$ , respectively. The particles obey Maxwell-Boltzmann statistics. The state of the combined two-particle system is expressed as
- (A)  $\phi_n(r_1) + \phi_s(r_2)$     (B)  $\frac{1}{\sqrt{2}} [\phi_n(r_1)\phi_s(r_2) + \phi_n(r_2)\phi_s(r_1)]$   
 (C)  $\frac{1}{\sqrt{2}} [\phi_n(r_1)\phi_s(r_2) - \phi_n(r_2)\phi_s(r_1)]$     (D)  $\phi_n(r_1)\phi_s(r_2)$
- Q.11 The target of an X-ray tube is subjected to an excitation voltage  $V$ . The wavelength of the emitted X-rays is proportional to
- (A)  $1/\sqrt{V}$     (B)  $\sqrt{V}$     (C)  $1/V$     (D)  $V$
- Q.12 The principal series of spectral lines of lithium is obtained by transitions between
- (A)  $nS$  and  $2P$ ,  $n > 2$     (B)  $nD$  and  $2P$ ,  $n > 2$   
 (C)  $nP$  and  $2S$ ,  $n > 2$     (D)  $nF$  and  $3D$ ,  $n > 3$

- Q.13 Which one of the following is NOT a correct statement about semiconductors?
- (A) The electrons and holes have different mobilities in a semiconductor
  - (B) In an  $n$ -type semiconductor, the Fermi level lies closer to the conduction band edge
  - (C) Silicon is a direct band gap semiconductor
  - (D) Silicon has diamond structure
- Q.14 Which one of the following axes of rotational symmetry is NOT permissible in single crystals?
- (A) two-fold axis
  - (B) three-fold axis
  - (C) four-fold axis
  - (D) five-fold axis
- Q.15 Weak nuclear forces act on
- (A) both hadrons and leptons
  - (B) hadrons only
  - (C) all particles
  - (D) all charged particles
- Q.16 Which one of the following disintegration series of the heavy elements will give  $^{209}\text{Bi}$  as a stable nucleus?
- (A) Thorium series
  - (B) Neptunium series
  - (C) Uranium series
  - (D) Actinium series
- Q.17 The order of magnitude of the binding energy per nucleon in a nucleus is
- (A)  $10^{-5}$  MeV
  - (B)  $10^{-3}$  MeV
  - (C) 0.1 MeV
  - (D) 10 MeV
- Q.18 The interaction potential between two quarks, separated by a distance  $r$  inside a nucleon, can be described by ( $a, b$  and  $\beta$  are positive constants)
- (A)  $ae^{-\beta r}$
  - (B)  $\frac{a}{r} + br$
  - (C)  $-\frac{a}{r} + br$
  - (D)  $\frac{a}{r}$
- Q.19 The high input impedance of field effect transistor (FET) amplifier is due to
- (A) the pinch-off voltage
  - (B) its very low gate current
  - (C) the source and drain being far apart
  - (D) the geometry of the FET

Q.20 The circuit shown in the figure functions as

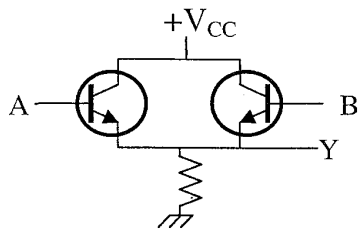

- (A) an **OR** gate      (B) an **AND** gate      (C) a **NOR** gate      (D) a **NAND** gate

**Q. 21 to Q. 75 carry two marks each.**

Q.21 A linear transformation  $T$ , defined as  $T \begin{pmatrix} x_1 \\ x_2 \\ x_3 \end{pmatrix} = \begin{pmatrix} x_1 + x_2 \\ x_2 - x_3 \end{pmatrix}$ , transforms a vector  $\vec{x}$  from a three-dimensional real space to a two-dimensional real space. The transformation matrix  $T$  is

- (A)  $\begin{pmatrix} 1 & 1 & 0 \\ 0 & 1 & -1 \end{pmatrix}$       (B)  $\begin{pmatrix} 1 & 0 & 0 \\ 0 & 1 & 0 \end{pmatrix}$       (C)  $\begin{pmatrix} 1 & 1 & 1 \\ -1 & 1 & 1 \end{pmatrix}$       (D)  $\begin{pmatrix} 1 & 0 & 0 \\ 0 & 0 & 1 \end{pmatrix}$

Q.22 The value of  $\oint_S \frac{\vec{r} \cdot d\vec{S}}{r^3}$ , where  $\vec{r}$  is the position vector and  $s$  is a closed surface enclosing the origin, is

- (A) 0      (B)  $\pi$       (C)  $4\pi$       (D)  $8\pi$

Q.23 The value of  $\oint_C \frac{e^{2z}}{(z+1)^4} dz$ , where  $c$  is a circle defined by  $|z| = 3$ , is

- (A)  $\frac{8\pi i}{3} e^{-2}$       (B)  $\frac{8\pi i}{3} e^{-1}$       (C)  $\frac{8\pi i}{3} e$       (D)  $\frac{8\pi i}{3} e^2$

Q.24 The  $k^{\text{th}}$  Fourier component of  $f(x) = \delta(x)$  is

- (A) 1      (B) 0      (C)  $(2\pi)^{-1/2}$       (D)  $(2\pi)^{-3/2}$

Q.25 An atom with net magnetic moment  $\vec{\mu}$  and net angular momentum  $\vec{L}$  ( $\vec{\mu} = \gamma \vec{L}$ ) is kept in a uniform magnetic induction  $\vec{B} = B_0 \hat{k}$ . The magnetic moment  $\vec{\mu}$  precesses about the  $z$ -axis. The equation of motion of the  $x$ -component of  $\vec{\mu}$  ( $= \mu_x$ ) is

- (A)  $\frac{d^2 \mu_x}{dt^2} + \gamma B_0 \mu_x = 0$       (B)  $\frac{d^2 \mu_x}{dt^2} + \gamma B_0 \frac{d\mu_x}{dt} + \mu_x = 0$   
 (C)  $\frac{d^2 \mu_x}{dt^2} + \gamma^2 B_0^2 \mu_x = 0$       (D)  $\frac{d^2 \mu_x}{dt^2} + 2\gamma B_0 \mu_x = 0$

Q.26 A particle is moving in a spherically symmetric potential  $V(r) = \alpha r^2$ , where  $\alpha$  is a positive constant. In a stationary state, the expectation value of the kinetic energy  $\langle T \rangle$  of the particle is

- (A)  $\langle T \rangle = \langle V \rangle$       (B)  $\langle T \rangle = 2\langle V \rangle$       (C)  $\langle T \rangle = 3\langle V \rangle$       (D)  $\langle T \rangle = 4\langle V \rangle$

Q.27 A particle of mass 2 kg is moving such that at time  $t$ , its position, in metre, is given by  $\vec{r}(t) = 5\hat{i} - 2t^2\hat{j}$ . The angular momentum of the particle at  $t = 2$  s about the origin, in  $\text{kg m}^2 \text{s}^{-1}$ , is

- (A)  $-40\hat{k}$       (B)  $-80\hat{k}$       (C)  $80\hat{k}$       (D)  $40\hat{k}$

Q.28 A system of four particles is in  $x$ - $y$  plane. Of these, two particles each of mass  $m$  are located at  $(-1, 1)$  and  $(1, -1)$ . The remaining two particles each of mass  $2m$  are located at  $(1, 1)$  and  $(-1, -1)$ . The  $xy$ -component of the moment of inertia tensor of this system of particles is

- (A)  $10m$       (B)  $-10m$       (C)  $2m$       (D)  $-2m$

Q.29 For the given transformations (i)  $Q = p, P = -q$  and (ii)  $Q = p, P = q$ , where  $p$  and  $q$  are canonically conjugate variables, which one of the following statements is true?

- (A) Both (i) and (ii) are canonical      (B) Only (i) is canonical  
 (C) Only (ii) is canonical      (D) Neither (i) nor (ii) is canonical

Q.30 The mass  $m$  of a moving particle is  $\frac{2m_0}{\sqrt{3}}$ , where  $m_0$  is its rest mass. The linear momentum of the particle is

- (A)  $2m_0c$       (B)  $\frac{2m_0c}{\sqrt{3}}$       (C)  $m_0c$       (D)  $\frac{m_0c}{\sqrt{3}}$

Q.31 Three point charges  $q, q$  and  $-2q$  are located at  $(0, -a, a), (0, a, a)$  and  $(0, 0, -a)$ , respectively. The net dipole moment of this charge distribution is

- (A)  $4qa\hat{k}$       (B)  $2qa\hat{k}$       (C)  $-4qa\hat{i}$       (D)  $-2qa\hat{j}$

Q.32 A long cylindrical conductor kept along  $z$ -axis carries a current density  $\vec{J} = J_0 r \hat{k}$ , where  $J_0$  is a constant and  $r$  is the radial distance from the axis of the cylinder. The magnetic induction  $\vec{B}$  inside the conductor at a distance  $d$  from the axis of the cylinder is

- (A)  $\mu_0 J_0 \hat{\phi}$       (B)  $-\frac{\mu_0 J_0 d}{2} \hat{\phi}$       (C)  $\frac{\mu_0 J_0 d^2}{3} \hat{\phi}$       (D)  $-\frac{\mu_0 J_0 d^3}{4} \hat{\phi}$

Q.33 The vector potential in a region is given as  $\vec{A}(x, y, z) = -y\hat{i} + 2x\hat{j}$ . The associated magnetic induction  $\vec{B}$  is

- (A)  $\hat{i} + \hat{k}$       (B)  $3\hat{k}$       (C)  $-\hat{i} + 2\hat{j}$       (D)  $-\hat{i} + \hat{j} + \hat{k}$

Q.34 At the interface between two linear dielectrics (with dielectric constants  $\epsilon_1$  and  $\epsilon_2$ ), the electric field lines bend, as shown in the figure. Assume that there are no free charges at the interface. The ratio  $\epsilon_1 / \epsilon_2$  is

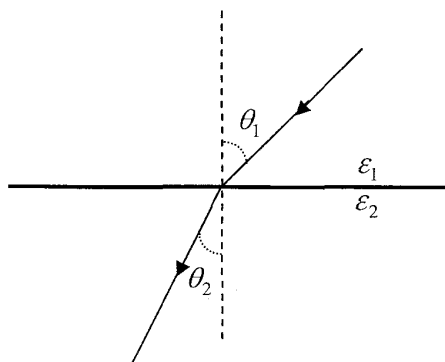

- (A)  $\tan \theta_1 / \tan \theta_2$       (B)  $\cos \theta_1 / \cos \theta_2$   
 (C)  $\sin \theta_1 / \sin \theta_2$       (D)  $\cot \theta_1 / \cot \theta_2$

Q.35 Which one of the following sets of Maxwell's equations for time-independent charge density  $\rho$  and current density  $\vec{J}$  is correct?

(A)

$$\begin{aligned}\vec{\nabla} \cdot \vec{E} &= \rho / \epsilon_0 \\ \vec{\nabla} \cdot \vec{B} &= 0 \\ \vec{\nabla} \times \vec{E} &= -\frac{\partial \vec{B}}{\partial t} \\ \vec{\nabla} \times \vec{B} &= \mu_0 \epsilon_0 \frac{\partial \vec{E}}{\partial t}\end{aligned}$$

(B)

$$\begin{aligned}\vec{\nabla} \cdot \vec{E} &= \rho / \epsilon_0 \\ \vec{\nabla} \cdot \vec{B} &= 0 \\ \vec{\nabla} \times \vec{E} &= 0 \\ \vec{\nabla} \times \vec{B} &= \mu_0 \vec{J}\end{aligned}$$

(C)

$$\begin{aligned}\vec{\nabla} \cdot \vec{E} &= 0 \\ \vec{\nabla} \cdot \vec{B} &= 0 \\ \vec{\nabla} \times \vec{E} &= 0 \\ \vec{\nabla} \times \vec{B} &= \mu_0 \vec{J}\end{aligned}$$

(D)

$$\begin{aligned}\vec{\nabla} \cdot \vec{E} &= \rho / \epsilon_0 \\ \vec{\nabla} \cdot \vec{B} &= \mu_0 |\vec{J}| \\ \vec{\nabla} \times \vec{E} &= 0 \\ \vec{\nabla} \times \vec{B} &= \mu_0 \epsilon_0 \frac{\partial \vec{E}}{\partial t}\end{aligned}$$

Q.36 A classical charged particle moving with frequency  $\omega$  in a circular orbit of radius  $a$ , centred at the origin in the  $x$ - $y$  plane, emits electromagnetic radiation. At points  $(b, 0, 0)$  and  $(0, 0, b)$ , where  $b \gg a$ , the electromagnetic waves are

- (A) circularly polarized and elliptically polarized, respectively
- (B) plane polarized and elliptically polarized, respectively
- (C) plane polarized and circularly polarized, respectively
- (D) circularly polarized and plane polarized, respectively

Q.37 A particle of mass  $m$  is represented by the wavefunction  $\psi(x) = Ae^{ikx}$ , where  $k$  is the wavevector and  $A$  is a constant. The magnitude of the probability current density of the particle is

- (A)  $|A|^2 \frac{\hbar k}{m}$
- (B)  $|A|^2 \frac{\hbar k}{2m}$
- (C)  $|A|^2 \frac{(\hbar k)^2}{m}$
- (D)  $|A|^2 \frac{(\hbar k)^2}{2m}$

Q.38 A one-dimensional harmonic oscillator is in the state

$\psi(x) = \frac{1}{\sqrt{14}} [3\psi_0(x) - 2\psi_1(x) + \psi_2(x)]$ , where  $\psi_0(x)$ ,  $\psi_1(x)$  and  $\psi_2(x)$  are the ground, first excited and second excited states, respectively. The probability of finding the oscillator in the ground state is

- (A) 0
- (B)  $\frac{3}{\sqrt{14}}$
- (C)  $\frac{9}{14}$
- (D) 1



Q.39 The wavefunction of a particle in a one-dimensional potential at time  $t = 0$  is  $\psi(x, t = 0) = \frac{1}{\sqrt{5}} [2\psi_0(x) - \psi_1(x)]$ , where  $\psi_0(x)$  and  $\psi_1(x)$  are the ground and the first excited states of the particle with corresponding energies  $E_0$  and  $E_1$ . The wavefunction of the particle at a time  $t$  is

- (A)  $\frac{1}{\sqrt{5}} e^{-i(E_0+E_1)t/\hbar} [2\psi_0(x) - \psi_1(x)]$       (B)  $\frac{1}{\sqrt{5}} e^{-iE_0t/\hbar} [2\psi_0(x) - \psi_1(x)]$   
 (C)  $\frac{1}{\sqrt{5}} e^{-iE_1t/\hbar} [2\psi_0(x) - \psi_1(x)]$       (D)  $\frac{1}{\sqrt{5}} \left[ 2\psi_0(x)e^{-iE_0t/\hbar} - \psi_1(x)e^{-iE_1t/\hbar} \right]$

Q.40 The commutator  $[L_x, y]$ , where  $L_x$  is the x-component of the angular momentum operator and  $y$  is the y-component of the position operator, is equal to

- (A) 0                      (B)  $i\hbar x$                       (C)  $i\hbar y$                       (D)  $i\hbar z$

Q.41 In hydrogenic states, the probability of finding an electron at  $r = 0$  is

- (A) zero in state  $\phi_{1s}(r)$                       (B) non-zero in state  $\phi_{1s}(r)$   
 (C) zero in state  $\phi_{2s}(r)$                       (D) non-zero in state  $\phi_{2p}(r)$

Q.42 Each of the two isolated vessels, A and B of fixed volumes, contains  $N$  molecules of a perfect monatomic gas at a pressure  $P$ . The temperatures of A and B are  $T_1$  and  $T_2$ , respectively. The two vessels are brought into thermal contact. At equilibrium, the change in entropy is

- (A)  $\frac{3}{2} Nk_B \ln \left[ \frac{T_1^2 + T_2^2}{4T_1T_2} \right]$                       (B)  $Nk_B \ln \left( \frac{T_2}{T_1} \right)$   
 (C)  $\frac{3}{2} Nk_B \ln \left[ \frac{(T_1 + T_2)^2}{4T_1T_2} \right]$                       (D)  $2Nk_B$

Q.43 The internal energy of  $n$  moles of a gas is given by  $E = \frac{3}{2} nRT - \frac{a}{V}$ , where  $V$  is the volume of the gas at temperature  $T$  and  $a$  is a positive constant. One mole of the gas in state  $(T_1, V_1)$  is allowed to expand adiabatically into vacuum to a final state  $(T_2, V_2)$ . The temperature  $T_2$  is

- (A)  $T_1 + Ra \left( \frac{1}{V_2} + \frac{1}{V_1} \right)$                       (B)  $T_1 - \frac{2}{3} Ra \left( \frac{1}{V_2} - \frac{1}{V_1} \right)$   
 (C)  $T_1 + \frac{2}{3} Ra \left( \frac{1}{V_2} - \frac{1}{V_1} \right)$                       (D)  $T_1 - \frac{1}{3} Ra \left( \frac{1}{V_2} - \frac{1}{V_1} \right)$

Q.44 The mean internal energy of a one-dimensional classical harmonic oscillator in equilibrium with a heat bath of temperature  $T$  is

- (A)  $\frac{1}{2}k_B T$       (B)  $k_B T$       (C)  $\frac{3}{2}k_B T$       (D)  $3k_B T$

Q.45 A monatomic crystalline solid comprises of  $N$  atoms, out of which  $n$  atoms are in interstitial positions. If the available interstitial sites are  $N'$ , the number of possible microstates is

- (A)  $\frac{(N'+n)!}{n!N!}$       (B)  $\frac{N!}{n!(N+n)!} \frac{N'}{n!(N'+n)!}$   
 (C)  $\frac{N!}{n!(N'-n)!}$       (D)  $\frac{N!}{n!(N-n)!} \frac{N'}{n!(N'-n)!}$

Q.46 A system of  $N$  localized, non-interacting spin  $\frac{1}{2}$  ions of magnetic moment  $\mu$  each is kept in an external magnetic field  $H$ . If the system is in equilibrium at temperature  $T$ , the Helmholtz free energy of the system is

- (A)  $Nk_B T \ln \left( \cosh \frac{\mu H}{k_B T} \right)$       (B)  $-Nk_B T \ln \left( 2 \cosh \frac{\mu H}{k_B T} \right)$   
 (C)  $Nk_B T \ln \left( 2 \cosh \frac{\mu H}{k_B T} \right)$       (D)  $-Nk_B T \ln \left( 2 \sinh \frac{\mu H}{k_B T} \right)$

Q.47 The phase diagram of a free particle of mass  $m$  and kinetic energy  $E$ , moving in a one-dimensional box with perfectly elastic walls at  $x = 0$  and  $x = L$ , is given by

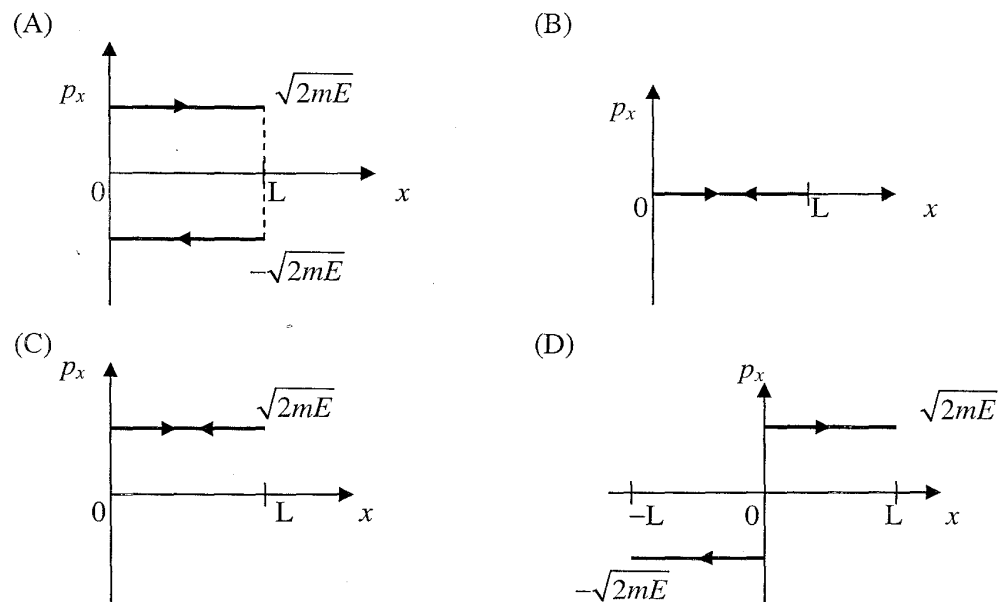

- Q.48 In the microwave spectrum of identical rigid diatomic molecules, the separation between the spectral lines is recorded to be  $0.7143 \text{ cm}^{-1}$ . The moment of inertia of the molecule, in  $\text{kg m}^2$ , is
- (A)  $2.3 \times 10^{-36}$       (B)  $2.3 \times 10^{-40}$       (C)  $7.8 \times 10^{-42}$       (D)  $7.8 \times 10^{-46}$
- Q.49 Which one of the following electronic transitions in neon is NOT responsible for LASER action in a helium-neon laser?
- (A)  $6s \rightarrow 5p$       (B)  $5s \rightarrow 4p$       (C)  $5s \rightarrow 3p$       (D)  $4s \rightarrow 3p$
- Q.50 In the linear Stark effect, the application of an electric field
- (A) completely lifts the degeneracy of  $n = 2$  level of hydrogen atom and splits  $n = 2$  level into four levels  
 (B) partially lifts the degeneracy of  $n = 2$  level of hydrogen atom and splits  $n = 2$  level into three levels  
 (C) partially lifts the degeneracy of  $n = 2$  level of hydrogen atom and splits  $n = 2$  level into two levels  
 (D) does not affect the  $n = 2$  levels
- Q.51 In hyperfine interaction, there is coupling between the electron angular momentum  $\vec{J}$  and nuclear angular momentum  $\vec{I}$ , forming resultant angular momentum  $\vec{F}$ . The selection rules for the corresponding quantum number  $F$  in hyperfine transitions are
- (A)  $\Delta F = \pm 2$  only      (B)  $\Delta F = \pm 1$  only  
 (C)  $\Delta F = 0, \pm 1$       (D)  $\Delta F = \pm 1, \pm 2$
- Q.52 A vibrational-electronic spectrum of homonuclear binary molecules, involving electronic ground state  $\varepsilon''$  and excited state  $\varepsilon'$ , exhibits a continuum at  $\bar{\nu} \text{ cm}^{-1}$ . If the total energy of the dissociated atoms in the excited state exceeds the total energy of the dissociated atoms in the ground state by  $E_{ex} \text{ cm}^{-1}$ , the dissociation energy of the molecule in the ground state is
- (A)  $(\bar{\nu} + E_{ex})/2$       (B)  $(\bar{\nu} - E_{ex})/2$       (C)  $(\bar{\nu} - E_{ex})$       (D)  $\sqrt{(\bar{\nu}^2 - E_{ex}^2)}$
- Q.53 The NMR spectrum of ethanol ( $\text{CH}_3\text{CH}_2\text{OH}$ ) comprises of three bunches of spectral lines. The number of spectral lines in the bunch corresponding to  $\text{CH}_2$  group is
- (A) 1      (B) 2      (C) 3      (D) 4
- Q.54 The energy  $E(\vec{k})$  of electrons of wavevector  $\vec{k}$  in a solid is given by  $E(\vec{k}) = Ak^2 + Bk^4$ , where  $A$  and  $B$  are constants. The effective mass of the electron at  $|\vec{k}| = k_0$  is
- (A)  $Ak_0^2$       (B)  $\frac{\hbar^2}{2A}$       (C)  $\frac{\hbar^2}{2A + 12Bk_0^2}$       (D)  $\frac{\hbar^2}{Bk_0^2}$

- Q.55 Which one of the following statements is NOT correct about the Brillouin zones (BZ) of a square lattice with lattice constant  $a$ ?
- (A) The first BZ is a square of side  $2\pi/a$  in  $k_x$ - $k_y$  plane  
 (B) The areas of the first BZ and third BZ are the same  
 (C) The  $k$ -points are equidistant in  $k_x$  as well as in  $k_y$  directions  
 (D) The area of the second BZ is twice that of the first BZ
- Q.56 In a crystal of  $N$  primitive cells, each cell contains two monovalent atoms. The highest occupied energy band of the crystal is
- (A) one-fourth filled (B) one-third filled  
 (C) half filled (D) completely filled
- Q.57 If the number density of a free electron gas changes from  $10^{28}$  to  $10^{26}$  electrons/m<sup>3</sup>, the value of plasma frequency (in Hz) changes from  $5.7 \times 10^{15}$  to
- (A)  $5.7 \times 10^{13}$  (B)  $5.7 \times 10^{14}$  (C)  $5.7 \times 10^{16}$  (D)  $5.7 \times 10^{17}$
- Q.58 Which one of the following statements about superconductors is NOT true?
- (A) A type I superconductor is completely diamagnetic  
 (B) A type II superconductor exhibits Meissner effect upto the second critical magnetic field ( $H_{c2}$ )  
 (C) A type II superconductor exhibits zero resistance upto the second critical magnetic field  
 (D) Both type I and type II superconductors exhibit sharp fall in resistance at the superconducting transition temperature
- Q.59 Two dielectric materials A and B exhibit both ionic and orientational polarizabilities. The variation of their susceptibilities  $\chi (= \epsilon_r - 1)$  with temperature  $T$  is shown in the figure, where  $\epsilon_r$  is the relative dielectric constant. It can be inferred from the figure that

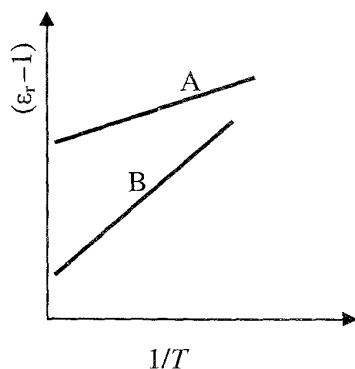

- (A) A is more polar and it has a smaller value of ionic polarizability than that of B  
 (B) A is more polar and it has a higher value of ionic polarizability than that of B  
 (C) B is more polar and it has a higher value of ionic polarizability than that of A  
 (D) B is more polar and it has a smaller value of ionic polarizability than that of A

Q.60 The experimentally measured spin  $g$  factors of a proton and a neutron indicate that

- (A) both proton and neutron are elementary point particles
- (B) both proton and neutron are not elementary point particles
- (C) while proton is an elementary point particle, neutron is not
- (D) while neutron is an elementary point particle, proton is not

Q.61 By capturing an electron,  ${}_{25}^{54}\text{Mn}_{29}$  transforms into  ${}_{24}^{54}\text{Cr}_{30}$  releasing

- (A) a neutrino
- (B) an antineutrino
- (C) an  $\alpha$ -particle
- (D) a positron

Q.62 Which one of the following nuclear processes is forbidden?

- (A)  $\bar{\nu} + p \rightarrow n + e^+$
- (B)  $\pi^- \rightarrow e^- + \nu_e + \pi^0$
- (C)  $\pi^- + p \rightarrow n + K^+ + K^-$
- (D)  $\mu^- \rightarrow e^- + \bar{\nu}_e + \nu_\mu$

Q.63 To explain the observed magnetic moment of a deuteron ( $0.8574 \mu_N$ ), its ground state wavefunction is taken to be an admixture of  $S$  and  $D$  states. The expectation values of the  $z$ -component of the magnetic moment in pure  $S$  and pure  $D$  states are  $0.8797 \mu_N$  and  $0.3101 \mu_N$ , respectively. The contribution of the  $D$  state to the mixed ground state is approximately

- (A) 40 %
- (B) 4 %
- (C) 0.4 %
- (D) 0.04 %

Q.64 A sinusoidal input voltage  $v_{in}$  of frequency  $\omega$  is fed to the circuit shown in the figure, where  $C_1 \gg C_2$ . If  $v_m$  is the peak value of the input voltage, the output voltage ( $v_{out}$ ) is

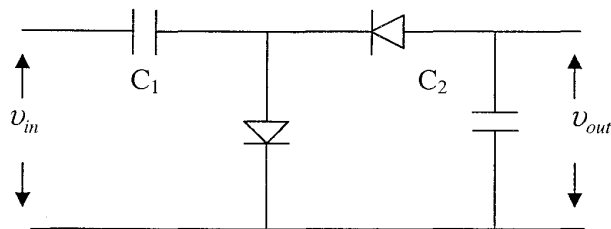

- (A)  $2v_m$
- (B)  $2v_0 \sin \omega t$
- (C)  $\sqrt{2} v_m$
- (D)  $\frac{v_m}{2} \sin \omega t$

Q.65 The low-pass active filter shown in the figure has a cut-off frequency of 2 kHz and a pass band gain of 1.5. The values of the resistors are

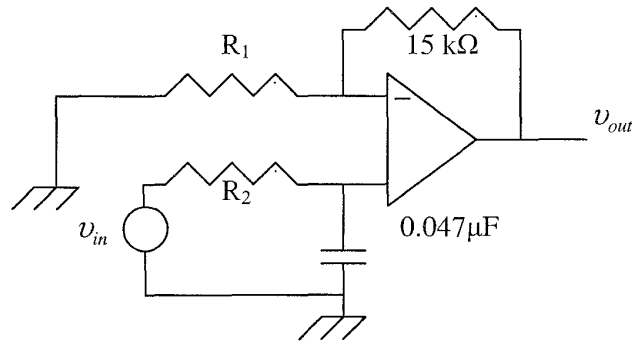

- (A)  $R_1 = 10 \text{ k}\Omega$ ;  $R_2 = 1.3 \text{ }\Omega$                       (B)  $R_1 = 30 \text{ k}\Omega$ ;  $R_2 = 1.3 \text{ }\Omega$   
 (C)  $R_1 = 10 \text{ k}\Omega$ ;  $R_2 = 1.7 \text{ k}\Omega$                       (D)  $R_1 = 30 \text{ k}\Omega$ ;  $R_2 = 1.7 \text{ k}\Omega$

Q.66 In order to obtain a solution of the differential equation  $\frac{d^2v}{dt^2} - 2\frac{dv}{dt} + v_1 = 0$ , involving voltages  $v(t)$  and  $v_1$ , an operational amplifier (Op-Amp) circuit would require at least

- (A) two Op-Amp integrators and one Op-Amp adder  
 (B) two Op-Amp differentiators and one Op-Amp adder  
 (C) one Op-Amp integrator and one Op-Amp adder  
 (D) one Op-Amp integrator, one Op-Amp differentiator and one Op-Amp adder

Q.67 In the given digital logic circuit, A and B form the input. The output Y is

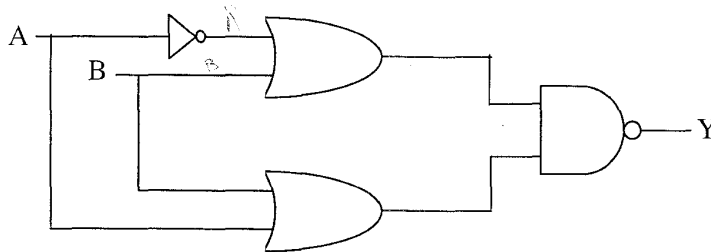

- (A)  $Y = \bar{A}$                       (B)  $Y = A\bar{B}$                       (C)  $Y = A \oplus B$                       (D)  $Y = \bar{B}$

Q.68 The largest analog output voltage from a 6-bit digital to analog converter (DAC) which produces 1.0 V output for a digital input of **010100**, is

- (A) 1.6 V                      (B) 2.9 V                      (C) 3.15 V                      (D) 5.0 V

Q.69 A ripple counter designed with JK flip-flops provided with CLEAR (CL) input is shown in the figure. In order that this circuit functions as a MOD-12 counter, the NAND gate input ( $X_1$  and  $X_2$ ) should be

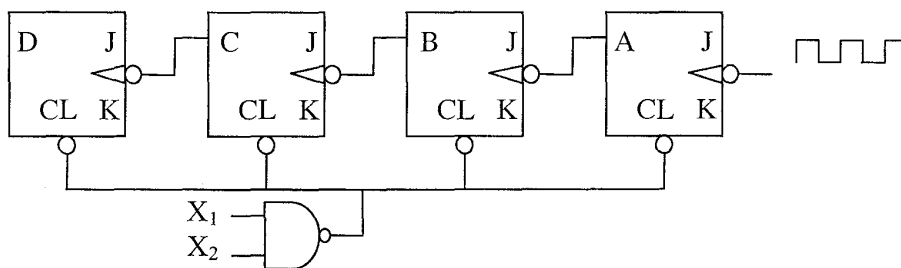

- (A) A and C      (B) A and D      (C) B and D      (D) C and D

Q.70 The tank circuit of a Hartley oscillator is shown in the figure. If  $M$  is the mutual inductance between the inductors, the oscillation frequency is

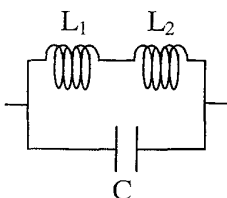

- (A)  $\frac{1}{2\pi\sqrt{(L_1+L_2+2M)C}}$       (B)  $\frac{1}{2\pi\sqrt{(L_1+L_2-2M)C}}$   
 (C)  $\frac{1}{2\pi\sqrt{(L_1+L_2+M)C}}$       (D)  $\frac{1}{2\pi\sqrt{(L_1+L_2-M)C}}$

### Common Data Questions

#### Common Data for Questions 71, 72, 73:

An unperturbed two-level system has energy eigenvalues  $E_1$  and  $E_2$ , and eigenfunctions

$$\begin{pmatrix} 1 \\ 0 \end{pmatrix} \text{ and } \begin{pmatrix} 0 \\ 1 \end{pmatrix}. \text{ When perturbed, its Hamiltonian is represented by } \begin{pmatrix} E_1 & A \\ A^* & E_2 \end{pmatrix}.$$

Q.71 The first-order correction to  $E_1$  is

- (A)  $4A$                       (B)  $2A$                       (C)  $A$                       (D)  $0$

Q.72 The second-order correction to  $E_1$  is

- (A)  $0$                       (B)  $A$                       (C)  $\frac{A^2}{E_2 - E_1}$                       (D)  $\frac{A^2}{E_1 - E_2}$

Q.73 The first-order correction to the eigenfunction  $\begin{pmatrix} 1 \\ 0 \end{pmatrix}$  is

- (A)  $\begin{pmatrix} 0 \\ A^*/(E_1 - E_2) \end{pmatrix}$                       (B)  $\begin{pmatrix} 0 \\ 1 \end{pmatrix}$                       (C)  $\begin{pmatrix} A^*/(E_1 - E_2) \\ 0 \end{pmatrix}$                       (D)  $\begin{pmatrix} 1 \\ 1 \end{pmatrix}$

#### Common Data for Questions 74, 75:

One of the eigenvalues of the matrix  $\begin{pmatrix} 2 & 3 & 0 \\ 3 & 2 & 0 \\ 0 & 0 & 1 \end{pmatrix}$  is 5.

Q.74 The other two eigenvalues are

- (A)  $0$  and  $0$                       (B)  $1$  and  $1$                       (C)  $1$  and  $-1$                       (D)  $-1$  and  $-1$

Q.75 The normalized eigenvector corresponding to the eigenvalue 5 is

- (A)  $\frac{1}{\sqrt{2}} \begin{pmatrix} 0 \\ -1 \\ 1 \end{pmatrix}$                       (B)  $\frac{1}{\sqrt{2}} \begin{pmatrix} -1 \\ 1 \\ 0 \end{pmatrix}$                       (C)  $\frac{1}{\sqrt{2}} \begin{pmatrix} 1 \\ 0 \\ -1 \end{pmatrix}$                       (D)  $\frac{1}{\sqrt{2}} \begin{pmatrix} 1 \\ 1 \\ 0 \end{pmatrix}$



**Linked Answer Questions: Q.76 to Q.85 carry two marks each.**

**Statement for Linked Answer Questions 76 & 77:**

The powder diffraction pattern of a body centred cubic crystal is recorded by using Cu K $\alpha$  X-rays of wavelength 1.54 Å.

- Q.76 If the (002) planes diffract at 60°, the lattice parameter is  
 (A) 2.67 Å                      (B) 3.08 Å                      (C) 3.56 Å                      (D) 5.34 Å
- Q.77 Assuming the atomic mass of the constituent atoms to be 50.94 amu, the density of the crystal in units of kg m<sup>-3</sup> is  
 (A) 3.75 × 10<sup>3</sup>                      (B) 4.45 × 10<sup>3</sup>                      (C) 5.79 × 10<sup>3</sup>                      (D) 8.89 × 10<sup>3</sup>

**Statement for Linked Answer Questions 78 & 79:**

A particle of mass  $m$  is constrained to move in a vertical plane along a trajectory given by  $x = A\cos\theta$ ,  $y = A\sin\theta$ , where  $A$  is a constant.

- Q.78 The Lagrangian of the particle is  
 (A)  $\frac{1}{2}mA^2\dot{\theta}^2 - mgA\cos\theta$                       (B)  $\frac{1}{2}mA^2\dot{\theta}^2 - mgA\sin\theta$   
 (C)  $\frac{1}{2}mA^2\dot{\theta}^2$                       (D)  $\frac{1}{2}mA^2\dot{\theta}^2 + mgA\cos\theta$
- Q.79 The equation of motion of the particle is  
 (A)  $\ddot{\theta} - \frac{g}{A}\cos\theta = 0$                       (B)  $\ddot{\theta} + \frac{g}{A}\sin\theta = 0$   
 (C)  $\ddot{\theta} = 0$                       (D)  $\ddot{\theta} - \frac{g}{A}\sin\theta = 0$

**Statement for Linked Answer Questions 80 & 81:**

A dielectric sphere of radius  $R$  carries polarization  $\vec{P} = kr^2\hat{r}$ , where  $r$  is the distance from the centre and  $k$  is a constant. In the spherical polar coordinate system,  $\hat{r}$ ,  $\hat{\theta}$  and  $\hat{\phi}$  are the unit vectors.

- Q.80 The bound volume charge density inside the sphere at a distance  $r$  from the centre is  
 (A)  $-4kR$                       (B)  $-4kr$                       (C)  $-4kr^2$                       (D)  $-4kr^3$
- Q.81 The electric field inside the sphere at a distance  $d$  from the centre is  
 (A)  $\frac{-kd^2}{\epsilon_0}\hat{r}$                       (B)  $\frac{-kR^2}{\epsilon_0}\hat{r}$                       (C)  $\frac{-kd^2}{\epsilon_0}\hat{\theta}$                       (D)  $\frac{-kR^2}{\epsilon_0}\hat{\theta}$



**Statement for Linked Answer Questions 82 & 83:**

Consider Fermi theory of  $\beta$ -decay.

- Q.82 The number of final states of electrons corresponding to momenta between  $p$  and  $p + dp$  is
- (A) independent of  $p$  (B) proportional to  $p dp$   
(C) proportional to  $p^2 dp$  (D) proportional to  $p^3 dp$
- Q.83 The number of emitted electrons with momentum  $p$  and energy  $E$ , in the allowed approximation, is proportional to ( $E_0$  is the total energy given up by the nucleus)
- (A)  $(E_0 - E)$  (B)  $p(E_0 - E)$  (C)  $p^2(E_0 - E)^2$  (D)  $p(E_0 - E)^2$

**Statement for Linked Answer Questions 84 & 85:**

Consider a radiation cavity of volume  $V$  at temperature  $T$ .

- Q.84 The density of states at energy  $E$  of the quantized radiation (photons) is
- (A)  $\frac{8\pi V}{h^3 c^3} E^2$  (B)  $\frac{8\pi V}{h^3 c^3} E^{\frac{3}{2}}$  (C)  $\frac{8\pi V}{h^3 c^2} E$  (D)  $\frac{8\pi V}{h^3 c^2} E^{\frac{1}{2}}$
- Q.85 The average number of photons in equilibrium inside the cavity is proportional to
- (A)  $T$  (B)  $T^2$  (C)  $T^3$  (D)  $T^4$

**END OF THE QUESTION PAPER**