

Some Useful Symbols

Speed of light in free space:	c
Boltzmann constant:	k_B
Electron charge :	e
Planck's constant:	h
Rest mass of electron:	m_e
Rest mass of proton:	m_p
Rest mass of neutron:	m_n
Permeability of free space:	μ_0
Permittivity of free space:	ϵ_0

All other symbols have their usual meanings unless otherwise specified.

Q. 1 – Q. 20 carry one mark each.

Q.1 The value of the contour integral, $\left| \int_C \vec{r} \times d\vec{\theta} \right|$, for a circle C of radius r with center at the origin is

- (A) $2\pi r$ (B) $r^2/2$ (C) πr^2 (D) r

Q.2 An electrostatic field \vec{E} exists in a given region R . Choose the WRONG statement.

- (A) Circulation of \vec{E} is zero
 (B) \vec{E} can always be expressed as the gradient of a scalar field
 (C) The potential difference between any two arbitrary points in the region R is zero
 (D) The work done in a closed path lying entirely in R is zero

Q.3 The Lagrangian of a free particle in spherical polar co-ordinates is given

by $L = \frac{1}{2} m (\dot{r}^2 + r^2 \dot{\theta}^2 + r^2 \dot{\phi}^2 \sin^2 \theta)$. The quantity that is conserved is

- (A) $\frac{\partial L}{\partial r}$ (B) $\frac{\partial L}{\partial \theta}$
 (C) $\frac{\partial L}{\partial \phi}$ (D) $\frac{\partial L}{\partial \phi} + r\dot{\theta}$

Q.4 A conducting loop L of surface area S is moving with a velocity \vec{v} in a magnetic field $\vec{B}(\vec{r}, t) = \vec{B}_0 t^2$, B_0 is a positive constant of suitable dimensions. The emf induced, V_{emf} , in the loop is given by

- (A) $-\int_S \frac{\partial \vec{B}}{\partial t} \cdot d\vec{S}$ (B) $\oint_L (\vec{v} \times \vec{B}) \cdot d\vec{L}$
 (C) $-\int_S \frac{\partial \vec{B}}{\partial t} \cdot d\vec{S} - \oint_L (\vec{v} \times \vec{B}) \cdot d\vec{L}$ (D) $-\int_S \frac{\partial \vec{B}}{\partial t} \cdot d\vec{S} + \oint_L (\vec{v} \times \vec{B}) \cdot d\vec{L}$

- Q.5 The eigenvalues of the matrix $A = \begin{pmatrix} 0 & i \\ i & 0 \end{pmatrix}$ are
- (A) real and distinct (B) complex and distinct
(C) complex and coinciding (D) real and coinciding
- Q.6 $\sigma_i (i = 1, 2, 3)$ represent the Pauli spin matrices. Which one of the following is NOT true ?
- (A) $\sigma_i \sigma_j + \sigma_j \sigma_i = 2\delta_{ij}$ (B) $Tr(\sigma_i) = 0$
(C) The eigenvalues of σ_i are ± 1 (D) $\det(\sigma_i) = 1$
- Q.7 Which one of the functions given below represents the bound state eigenfunction of the operator $-\frac{d^2}{dx^2}$ in the region, $0 \leq x < \infty$, with the eigenvalue -4 ?
- (A) $A_0 e^{2x}$ (B) $A_0 \cosh 2x$
(C) $A_0 e^{-2x}$ (D) $A_0 \sinh 2x$
- Q.8 Pick the WRONG statement.
- (A) The nuclear force is independent of electric charge
(B) The Yukawa potential is proportional to $r^{-1} \exp\left(-\frac{mc}{\hbar} r\right)$, where r is the separation between two nucleons
(C) The range of nuclear force is of the order of $10^{-15}m - 10^{-14}m$
(D) The nucleons interact among each other by the exchange of mesons
- Q.9 If p and q are the position and momentum variables, which one of the following is NOT a canonical transformation ?
- (A) $Q = \alpha q$ and $P = \frac{1}{\alpha} p$, for $\alpha \neq 0$
(B) $Q = \alpha q + \beta p$ and $P = \beta q + \alpha p$ for α, β real and $\alpha^2 - \beta^2 = 1$
(C) $Q = p$ and $P = q$
(D) $Q = p$ and $P = -q$
- Q.10 The Common Mode Rejection Ratio (CMRR) of a differential amplifier using an operational amplifier is 100 dB. The output voltage for a differential input of 200 μ V is 2 V. The common mode gain is
- (A) 10 (B) 0.1
(C) 30 dB (D) 10 dB
- Q.11 In an insulating solid which one of the following physical phenomena is a consequence of Pauli's exclusion principle ?
- (A) Ionic conductivity
(B) Ferromagnetism
(C) Paramagnetism
(D) Ferroelectricity

2009

Q.12 Which one of the following curves gives the solution of the differential equation $k_1 \frac{dx}{dt} + k_2 x = k_3$, where k_1, k_2 and k_3 are positive constants with initial conditions $x = 0$ at $t = 0$?

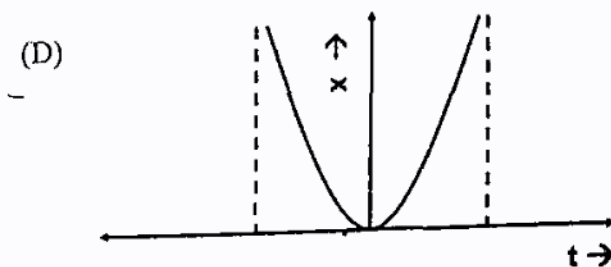
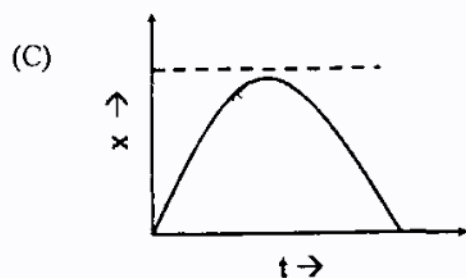
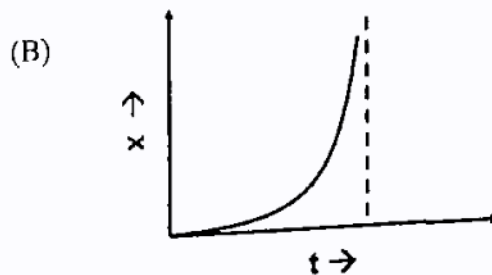
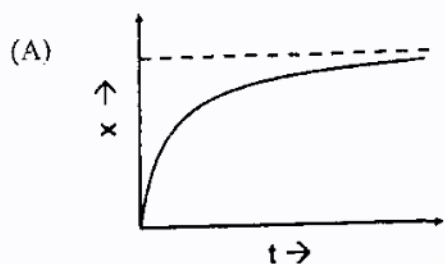

Q.13 Identify which one is a first order phase transition ?

- (A) A liquid to gas transition at its critical temperature.
 (B) A liquid to gas transition close to its triple point.
 (C) A paramagnetic to ferromagnetic transition in the absence of a magnetic field.
 (D) A metal to superconductor transition in the absence of a magnetic field.

Q.14 Group I lists some physical phenomena while Group II gives some physical parameters. Match the phenomena with the corresponding parameter.

Group I

- P. Doppler Broadening
 Q. Natural Broadening
 R. Rotational spectrum
 S. Total internal reflection

Group II

1. Moment of inertia
 2. Refractive index
 3. Lifetime of the energy level
 4. Pressure

- (A) P-4, Q-3, R-1, S-2
 (B) P-3, Q-2, R-1, S-4
 (C) P-2, Q-3, R-4, S-1
 (D) P-1, Q-4, R-2, S-3

Q.15 The separation between the first Stokes and corresponding anti-Stokes lines of the rotational Raman spectrum in terms of the rotational constant, B is

- (A) 2B (B) 4B (C) 6B (D) 12B

Q.16 A superconducting ring is cooled in the presence of a magnetic field below its critical temperature (T_c). The total magnetic flux that passes through the ring is

- (A) zero (B) $n \frac{h}{2e}$
 (C) $\frac{nh}{4\pi e}$ (D) $\frac{ne^2}{hc}$

- Q.17 In a cubic crystal, atoms of mass M_1 lie on one set of planes and atoms of mass M_2 lie on planes interleaved between those of the first set. If C is the force constant between nearest neighbour planes, the frequency of lattice vibrations for the optical phonon branch with wavevector $k = 0$ is

(A) $\sqrt{2C \left(\frac{1}{M_1} + \frac{1}{M_2} \right)}$

(B) $\sqrt{C \left(\frac{1}{2M_1} + \frac{1}{M_2} \right)}$

(C) $\sqrt{C \left(\frac{1}{M_1} + \frac{1}{2M_2} \right)}$

(D) 0

- Q.18 In the quark model which one of the following represents a proton ?

(A) udd

(B) uud

(C) $u\bar{b}$

(D) $c\bar{c}$

Q.19

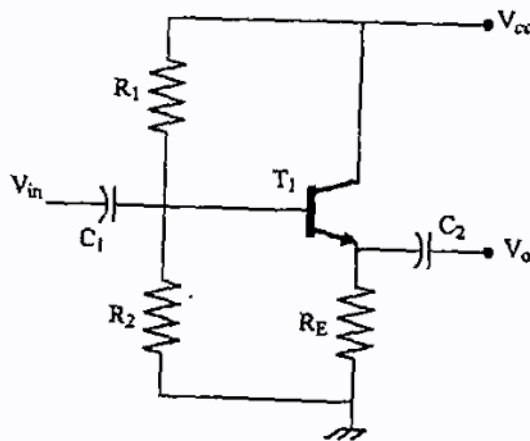

The circuit shown above

- (A) is a common-emitter amplifier
 (B) uses a *pnp* transistor
 (C) is an oscillator
 (D) has a voltage gain less than one
- Q.20 Consider a nucleus with N neutrons and Z protons. If m_p , m_n and BE represent the mass of the proton, the mass of the neutron and the binding energy of the nucleus respectively and c is the velocity of light in free space, the mass of the nucleus is given by
- (A) $Nm_n + Zm_p$
 (B) $Nm_p + Zm_n$
 (C) $Nm_n + Zm_p + \frac{BE}{c^2}$
 (D) $Nm_p + Zm_n + \frac{BE}{c^2}$

2009

Q. 21 to Q. 60 carry two marks each.

- Q.21 The magnetic field (in $A\ m^{-1}$) inside a long solid cylindrical conductor of radius $a = 0.1\ m$ is,

$$\vec{H} = \frac{10^4}{r} \left[\frac{1}{\alpha^2} \sin(\alpha r) - \frac{r}{\alpha} \cos(\alpha r) \right] \hat{\phi}, \text{ where } \alpha = \frac{\pi}{2a}. \text{ What is the total current (in } A \text{) in the conductor?}$$

- (A) $\frac{\pi}{2a}$ (B) $\frac{800}{\pi}$ (C) $\frac{400}{\pi}$ (D) $\frac{300}{\pi}$

- Q.22 Which one of the following current densities, \vec{J} , can generate the magnetic vector potential $\vec{A} = (y^2 \hat{i} + x^2 \hat{j})$?

- (A) $\frac{2}{\mu_0} (x\hat{i} + y\hat{j})$ (B) $-\frac{2}{\mu_0} (\hat{i} + \hat{j})$
 (C) $\frac{2}{\mu_0} (\hat{i} - \hat{j})$ (D) $\frac{2}{\mu_0} (x\hat{i} - y\hat{j})$

- Q.23 The value of the integral $\int_C \frac{e^z}{z^2 - 3z + 2} dz$, where the contour C is the circle $|z| = 3/2$ is

- (A) $2\pi ie$ (B) πie (C) $-2\pi ie$ (D) $-\pi ie$

- Q.24 In a non-conducting medium characterized by $\epsilon = \epsilon_0$, $\mu = \mu_0$ and conductivity $\sigma = 0$, the electric field (in $V\ m^{-1}$) is given by $\vec{E} = 20 \sin[10^8 t - kz] \hat{j}$. The magnetic field, \vec{H} (in $A\ m^{-1}$), is given by

- (A) $20k \cos[10^8 t - kz] \hat{i}$
 (B) $\frac{20k}{10^8 \mu_0} \sin[10^8 t - kz] \hat{j}$
 (C) $-\frac{20k}{10^8 \mu_0} \sin[10^8 t - kz] \hat{i}$
 (D) $-20k \cos[10^8 t - kz] \hat{j}$

- Q.25 A cylindrical rod of length L and radius r , made of an inhomogeneous dielectric, is placed with its axis along the z direction with one end at the origin as shown below.

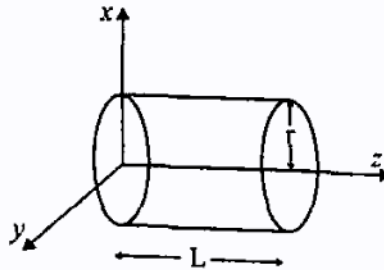

If the rod carries a polarization, $\vec{P} = (5z^2 + 7) \hat{k}$, the volume bound charge inside the dielectric is

- (A) Zero (B) $10\pi r^2 L$ (C) $-5\pi r^2 L$ (D) $-5\pi r^2 L^2$

Q.26 Let $T_{ij} = \sum_k \epsilon_{ijk} a_k$ and $\beta_k = \sum_{i,j} \epsilon_{ijk} T_{ij}$, where ϵ_{ijk} is the Levi-Civita density, defined to be zero if two of the indices coincide and +1 and -1 depending on whether ijk is even or odd permutation of 1,2,3. Then β_1 is equal to

- (A) $2a_3$ (B) $-2a_3$ (C) a_3 (D) $-a_3$

Q.27 The dependence of the magnetic susceptibility (χ) of a material with temperature (T) can be represented by $\chi \propto \frac{1}{T - \theta}$, where θ is the Curie-Weiss temperature. The plot of magnetic susceptibility versus temperature is sketched in the figure, as curves P, Q and R with curve Q having $\theta = 0$. Which one of the following statements is correct ?

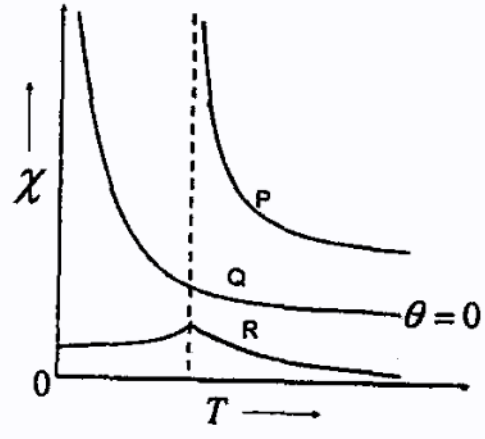

- (A) Curve R represents a paramagnet and Q a ferromagnet
 (B) Curve Q represents a ferromagnet and P an antiferromagnet
 (C) Curve R represents an antiferromagnet and Q a paramagnet
 (D) Curve R represents an antiferromagnet and Q a ferromagnet

Q.28 The dielectric constant of a material at optical frequencies is mainly due to

- (A) ionic polarizability
 (B) electronic polarizability
 (C) dipolar polarizability
 (D) ionic and dipolar polarizability

Q.29 An electron of wavevector \vec{k}_e , velocity \vec{v}_e and effective mass m_e is removed from a filled energy band. The resulting hole has wavevector \vec{k}_h , velocity \vec{v}_h , and effective mass m_h . Which one of the following statements is correct ?

- (A) $\vec{k}_h = -\vec{k}_e$; $\vec{v}_h = -\vec{v}_e$; $m_h = -m_e$
 (B) $\vec{k}_h = \vec{k}_e$; $\vec{v}_h = \vec{v}_e$; $m_h = m_e$
 (C) $\vec{k}_h = \vec{k}_e$; $\vec{v}_h = -\vec{v}_e$; $m_h = -m_e$
 (D) $\vec{k}_h = -\vec{k}_e$; $\vec{v}_h = \vec{v}_e$; $m_h = -m_e$

2009

Q.30 In a diatomic molecule, the internuclear separation of the ground and first excited electronic state are the same as shown in the figure. If the molecule is initially in the lowest vibrational state of the ground state, then the absorption spectrum will appear as

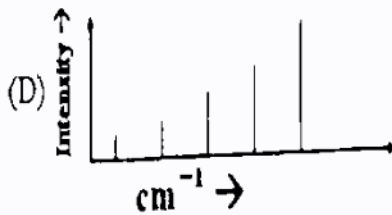
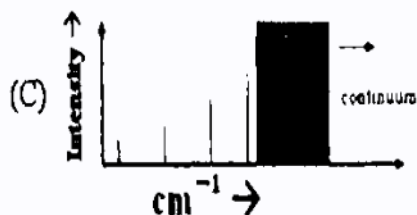
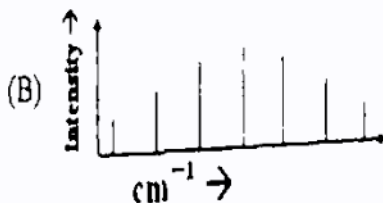
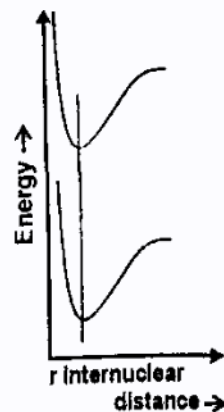

Q.31 Five energy levels of a system including the ground state are shown below. Their lifetimes and the allowed electric dipole transitions are also marked.

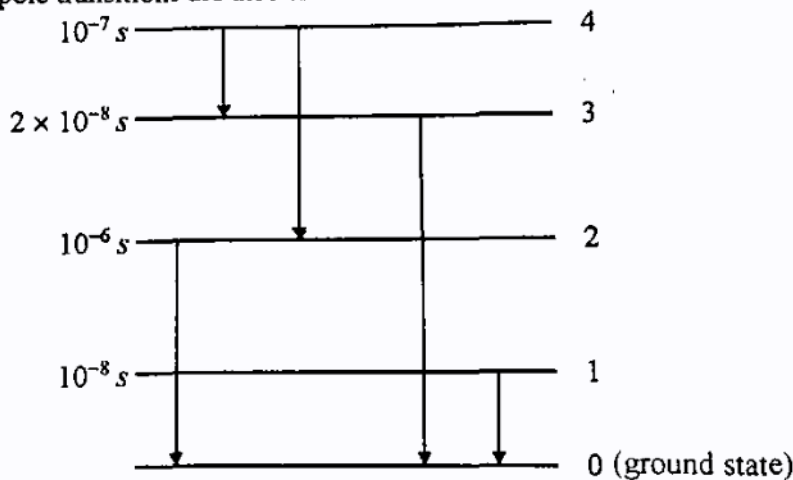

Which one of the following transitions is the most suitable for a continuous wave (CW) laser ?

- (A) $1 \rightarrow 0$ (B) $2 \rightarrow 0$ (C) $4 \rightarrow 2$ (D) $4 \rightarrow 3$

Q.32 Assuming the mean life time of a muon (in its rest frame) to be $2 \times 10^{-6} s$, its life time in the laboratory frame, when it is moving with a velocity $0.95c$ is

- (A) $6.4 \times 10^{-6} s$ (B) $0.62 \times 10^{-6} s$ (C) $2.16 \times 10^{-6} s$ (D) $0.19 \times 10^{-6} s$

Q.33 Cesium has a nuclear spin of $7/2$. The hyperfine spectrum of the D lines of the cesium atom will consist of

- (A) 10 lines (B) 4 lines (C) 6 lines (D) 14 lines

Q.34 The probability that an energy level ε at a temperature T is *unoccupied* by a fermion of chemical potential μ is given by

(A) $\frac{1}{e^{(\varepsilon-\mu)/k_B T} + 1}$ (B) $\frac{1}{e^{(\varepsilon-\mu)/k_B T} - 1}$ (C) $\frac{1}{e^{(\mu-\varepsilon)/k_B T} + 1}$ (D) $\frac{1}{e^{(\mu-\varepsilon)/k_B T} - 1}$

Q.35 Consider the following expression for the mass of a nucleus with Z protons and A nucleons:

$$M(A, Z) = \frac{1}{c^2} (f(A) + yZ + zZ^2). \text{ Here } f(A) \text{ is a function of } A,$$

$$y = -4a_A,$$

$$z = a_c A^{-1/3} + 4a_A A^{-1},$$

a_A and a_c are constants of suitable dimensions. For a fixed A , the expression of Z for the most stable nucleus is

(A) $Z = \frac{A/2}{1 + \left(\frac{a_c}{a_A}\right) A^{2/3}}$

(B) $Z = \frac{A/2}{1 + \left(\frac{a_c}{4a_A}\right) A^{2/3}}$

(C) $Z = \frac{A}{1 + \left(\frac{a_c}{4a_A}\right) A^{2/3}}$

(D) $Z = \frac{A}{1 + A^{2/3}}$

Q.36 The de Broglie wavelength of particles of mass m with average momentum p at a temperature T in three dimensions is given by

(A) $\lambda = \frac{h}{\sqrt{2mk_B T}}$ (B) $\lambda = \frac{h}{\sqrt{3mk_B T}}$ (C) $\lambda = \frac{h}{\sqrt{2k_B T}}$ (D) $\lambda = \frac{h}{\sqrt{3m}}$

Q.37

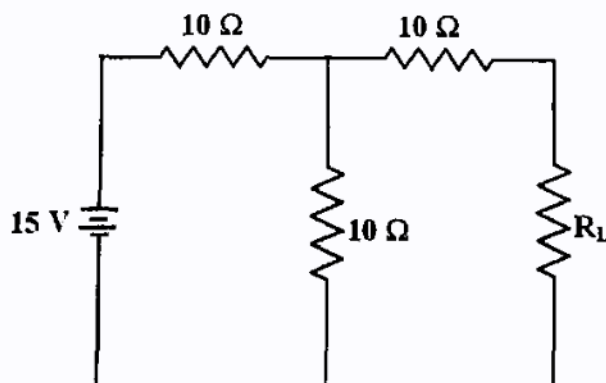

Assuming an ideal voltage source, Thevenin's resistance and Thevenin's voltage respectively for the above circuit are

(A) 15Ω and 7.5 V (B) 20Ω and 5 V (C) 10Ω and 10 V (D) 30Ω and 15 V

2009

Q.38 Let $|n\rangle$ and $|p\rangle$ denote the isospin states with $I = \frac{1}{2}$, $I_3 = \frac{1}{2}$ and $I = \frac{1}{2}$, $I_3 = -\frac{1}{2}$ of a nucleon respectively. Which one of the following two-nucleon states has $I = 0$, $I_3 = 0$?

- (A) $\frac{1}{\sqrt{2}}(|nn\rangle - |pp\rangle)$ (B) $\frac{1}{\sqrt{2}}(|nn\rangle + |pp\rangle)$
 (C) $\frac{1}{\sqrt{2}}(|np\rangle - |pn\rangle)$ (D) $\frac{1}{\sqrt{2}}(|np\rangle + |pn\rangle)$

Q.39 An amplifier of gain 1000 is made into a feedback amplifier by feeding 9.9 % of its output voltage in series with the input opposing. If $f_L = 20$ Hz and $f_H = 200$ kHz for the amplifier without feedback, then due to the feedback

- (A) the gain decreases by 10 times
 (B) the output resistance increases by 10 times
 (C) the f_H increases by 100 times
 (D) the input resistance decreases by 100 times

Q.40

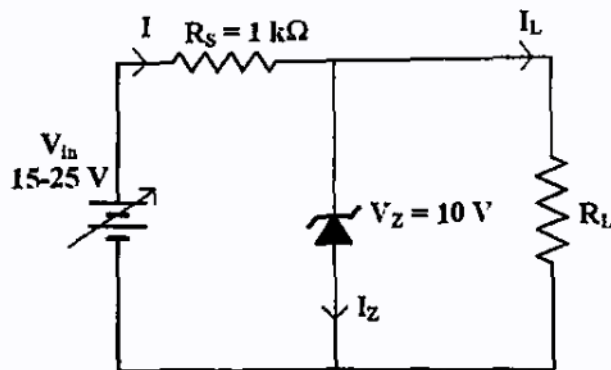

Pick the correct statement based on the above circuit.

- (A) The maximum Zener current, $I_{Z(max)}$, when $R_L = 10$ kΩ is 15 mA
 (B) The minimum Zener current, $I_{Z(min)}$, when $R_L = 10$ kΩ is 5 mA
 (C) With $V_{in} = 20$ V, $I_L = I_Z$, when $R_L = 2$ kΩ
 (D) The power dissipated across the Zener when $R_L = 10$ kΩ and $V_{in} = 20$ V is 100 mW
- Q 41 The disintegration energy is defined to be the difference in the rest energy between the initial and final states. Consider the following process :

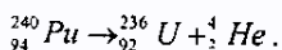

The emitted α particle has a kinetic energy 5.17 MeV. The value of the disintegration energy is

- (A) 5.26 MeV (B) 5.17 MeV (C) 5.08 MeV (D) 2.59 MeV

Q.42 A classical particle is moving in an external potential field $V(x, y, z)$ which is invariant under the following infinitesimal transformations

$$x \rightarrow x' = x + \delta x,$$

$$y \rightarrow y' = y + \delta y,$$

$$\begin{pmatrix} x \\ y \end{pmatrix} \rightarrow \begin{pmatrix} x' \\ y' \end{pmatrix} = R_z \begin{pmatrix} x \\ y \end{pmatrix},$$

where R_z is the matrix corresponding to rotation about the z axis. The conserved quantities are (the symbols have their usual meaning)

(A) p_x, p_z, L_z (B) p_x, p_y, L_z, E (C) p_y, L_z, E (D) p_y, p_x, L_x, E

Q.43 The spin function of a free particle, in the basis in which S_z is diagonal, can be written as

$\begin{pmatrix} 1 \\ 0 \end{pmatrix}$ and $\begin{pmatrix} 0 \\ 1 \end{pmatrix}$ with eigenvalues $+\frac{\hbar}{2}$ and $-\frac{\hbar}{2}$, respectively. In the given basis, the normalized eigenfunction of S_y with eigenvalue $-\frac{\hbar}{2}$

(A) $\frac{1}{\sqrt{2}} \begin{pmatrix} 1 \\ i \end{pmatrix}$ (B) $\frac{1}{\sqrt{2}} \begin{pmatrix} 0 \\ i \end{pmatrix}$ (C) $\frac{1}{\sqrt{2}} \begin{pmatrix} i \\ 0 \end{pmatrix}$ (D) $\frac{1}{\sqrt{2}} \begin{pmatrix} i \\ 1 \end{pmatrix}$

Q.44 \hat{A} and \hat{B} represent two physical characteristics of a quantum system. If \hat{A} is Hermitian, then for the product $\hat{A}\hat{B}$ to be Hermitian, it is sufficient that

(A) \hat{B} is Hermitian (B) \hat{B} is anti-Hermitian
(C) \hat{B} is Hermitian and \hat{A} and \hat{B} commute (D) \hat{B} is Hermitian and \hat{A} and \hat{B} anti-commute

Q.45 Consider the set of vectors in three-dimensional real vector space

$\mathbf{R}^3, S = \{(1, 1, 1), (1, -1, 1), (1, 1, -1)\}$. Which one of the following statements is true?

- (A) S is not a linearly independent set.
(B) S is a basis for \mathbf{R}^3 .
(C) The vectors in S are orthogonal.
(D) An orthogonal set of vectors cannot be generated from S .

Q.46 For a Fermi gas of N particles in three dimensions at $T = 0$ K, the Fermi energy, E_F is proportional to

(A) $N^{2/3}$ (B) $N^{3/2}$ (C) N^3 (D) N^2

2009

Q.47 The Lagrangian of a diatomic molecule is given by $L = \frac{m}{2}(\dot{x}_1^2 + \dot{x}_2^2) - \frac{k}{2}x_1x_2$, where m is the mass of each of the atoms and x_1 and x_2 are the displacements of atoms measured from the equilibrium position and $k > 0$. The normal frequencies are

(A) $\pm\left(\frac{k}{m}\right)^{1/2}$ (B) $\pm\left(\frac{k}{m}\right)^{1/4}$ (C) $\pm\left(\frac{k}{2m}\right)^{1/4}$ (D) $\pm\left(\frac{k}{2m}\right)^{1/2}$

Q.48 A particle is in the normalized state $|\psi\rangle$ which is a superposition of the energy eigenstates $|E_0 = 10\text{eV}\rangle$ and $|E_1 = 30\text{eV}\rangle$. The average value of energy of the particle in the state $|\psi\rangle$ is 20 eV. The state $|\psi\rangle$ is given by

(A) $\frac{1}{2}|E_0 = 10\text{eV}\rangle + \frac{\sqrt{3}}{4}|E_1 = 30\text{eV}\rangle$ (B) $\frac{1}{\sqrt{3}}|E_0 = 10\text{eV}\rangle + \sqrt{\frac{2}{3}}|E_1 = 30\text{eV}\rangle$

(C) $\frac{1}{2}|E_0 = 10\text{eV}\rangle - \frac{\sqrt{3}}{4}|E_1 = 30\text{eV}\rangle$ (D) $\frac{1}{\sqrt{2}}|E_0 = 10\text{eV}\rangle - \frac{1}{\sqrt{2}}|E_1 = 30\text{eV}\rangle$

Q.49 The Lagrangian of a particle of mass m moving in one dimension is $L = \exp(\alpha t) \left[\frac{m\dot{x}^2}{2} - \frac{kx^2}{2} \right]$, where α and k are positive constants. The equation of motion of the particle is

(A) $\ddot{x} + \alpha\dot{x} = 0$

(B) $\ddot{x} + \frac{k}{m}x = 0$

(C) $\ddot{x} - \alpha\dot{x} + \frac{k}{m}x = 0$

(D) $\ddot{x} + \alpha\dot{x} + \frac{k}{m}x = 0$

Q.50 Two monochromatic waves having frequencies ω and $\omega + \Delta\omega$ ($\Delta\omega \ll \omega$) and corresponding wavelengths λ and $\lambda - \Delta\lambda$ ($\Delta\lambda \ll \lambda$) of same polarization, traveling along x -axis are superimposed on each other. The phase velocity and group velocity of the resultant wave are respectively given by

(A) $\frac{\omega\lambda}{2\pi}, \frac{\Delta\omega\lambda^2}{2\pi\Delta\lambda}$

(B) $\omega\lambda, \frac{\Delta\omega\lambda^2}{\Delta\lambda}$

(C) $\frac{\omega\Delta\lambda}{2\pi}, \frac{\Delta\omega\Delta\lambda}{2\pi}$

(D) $\omega\Delta\lambda, \omega\Delta\lambda$

Common Data Questions**Common Data for Questions 51 and 52 :**Consider a two level quantum system with energies $\varepsilon_1 = 0$ and $\varepsilon_2 = \varepsilon$.

Q.51 The Helmholtz free energy of the system is given by

- (A) $-k_B T \ln(1 + e^{-\varepsilon/k_B T})$ (B) $k_B T \ln(1 + e^{-\varepsilon/k_B T})$
 (C) $\frac{3}{2} k_B T$ (D) $\varepsilon - k_B T$

Q.52 The specific heat of the system is given by

- (A) $\frac{\varepsilon}{k_B T} \frac{e^{-\varepsilon/k_B T}}{(1 + e^{-\varepsilon/k_B T})^2}$ (B) $\frac{\varepsilon^2}{k_B T^2} \frac{e^{-\varepsilon/k_B T}}{(1 + e^{-\varepsilon/k_B T})}$
 (C) $-\frac{\varepsilon^2 e^{-\varepsilon/k_B T}}{(1 + e^{-\varepsilon/k_B T})^2}$ (D) $\frac{\varepsilon^2}{k_B T^2} \frac{e^{-\varepsilon/k_B T}}{(1 + e^{-\varepsilon/k_B T})^2}$

Common Data for Questions 53 and 54 :A free particle of mass m moves along the x direction. At $t=0$, the normalized wave function of the particle is given by $\psi(x, 0) = \frac{1}{(2\pi\alpha)^{1/4}} \exp\left[-\frac{x^2}{4\alpha^2} + ix\right]$, where α is a real constant.

Q.53 The expectation value of the momentum, in this state is

- (A) $\hbar\alpha$ (B) $\hbar\sqrt{\alpha}$ (C) α (D) $\hbar/\sqrt{\alpha}$

Q.54 The expectation value of the particle energy is

- (A) $\frac{\hbar^2}{2m} \frac{1}{2\alpha^{3/2}}$ (B) $\frac{\hbar^2}{2m} \alpha^2$ (C) $\frac{\hbar^2}{2m} \frac{4\alpha^2 + 1}{4\alpha^{3/2}}$ (D) $\frac{\hbar^2}{8m\alpha^{3/2}}$

Common Data for Questions 55 and 56 :Consider the Zeeman splitting of a single electron system for the $3d \rightarrow 3p$ electric dipole transition.

Q.55 The Zeeman spectrum is

- (A) randomly polarized (B) only π polarized
 (C) only σ polarized (D) both π and σ polarized

Q.56 The fine structure line having the longest wavelength will split into

- (A) 17 components (B) 10 components (C) 8 components (D) 4 components

2009

Linked Answer Questions

Statement for Linked Answer Questions 57 and 58 :

The primitive translation vectors of the face centered cubic (fcc) lattice are

$$\hat{a}_1 = \frac{a}{2}(\hat{j} + \hat{k}); \hat{a}_2 = \frac{a}{2}(\hat{i} + \hat{k}); \hat{a}_3 = \frac{a}{2}(\hat{i} + \hat{j}).$$

Q.57 The primitive translation vectors of the fcc reciprocal lattice are

(A) $\hat{b}_1 = \left(\frac{2\pi}{a}\right)(-\hat{i} + \hat{j} + \hat{k}); \hat{b}_2 = \left(\frac{2\pi}{a}\right)(\hat{i} - \hat{j} + \hat{k}); \hat{b}_3 = \left(\frac{2\pi}{a}\right)(\hat{i} + \hat{j} - \hat{k})$

(B) $\hat{b}_1 = \left(\frac{\pi}{a}\right)(-\hat{i} + \hat{j} + \hat{k}); \hat{b}_2 = \left(\frac{\pi}{a}\right)(\hat{i} - \hat{j} + \hat{k}); \hat{b}_3 = \left(\frac{\pi}{a}\right)(\hat{i} + \hat{j} - \hat{k})$

(C) $\hat{b}_1 = \left(\frac{\pi}{2a}\right)(-\hat{i} + \hat{j} + \hat{k}); \hat{b}_2 = \left(\frac{\pi}{2a}\right)(\hat{i} - \hat{j} + \hat{k}); \hat{b}_3 = \left(\frac{\pi}{2a}\right)(\hat{i} + \hat{j} - \hat{k})$

(D) $\hat{b}_1 = \left(\frac{3\pi}{a}\right)(-\hat{i} + \hat{j} + \hat{k}); \hat{b}_2 = \left(\frac{3\pi}{a}\right)(\hat{i} - \hat{j} + \hat{k}); \hat{b}_3 = \left(\frac{3\pi}{a}\right)(\hat{i} + \hat{j} - \hat{k})$

Q.58 The volume of the primitive cell of the fcc reciprocal lattice is

- (A) $4\left(\frac{2\pi}{a}\right)^3$ (B) $4\left(\frac{\pi}{a}\right)^3$ (C) $4\left(\frac{\pi}{2a}\right)^3$ (D) $4\left(\frac{3\pi}{a}\right)^3$

Statement for Linked Answer Questions 59 and 60 :

The Karnaugh map of a logic circuit is shown below:

	\bar{R}	R
$\bar{P}\bar{Q}$	1	1
$\bar{P}Q$	1	
PQ		
$P\bar{Q}$	1	1

Q.59 The minimized logic expression for the above map is

- (A) $Y = \bar{P}\bar{R} + \bar{Q}$ (B) $Y = \bar{Q} \cdot PR$ (C) $Y = \bar{Q} + PR$ (D) $Y = Q \cdot \bar{P}\bar{R}$

Q.60 The corresponding logic implementation using gates is given as:

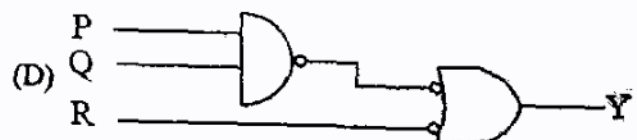
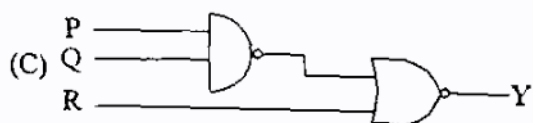
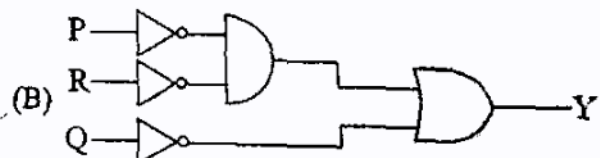
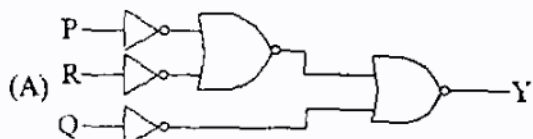

END OF THE QUESTION PAPER