



PHYSICS



**STUDENT SUPPORT MATERIAL
FOR SSLC EXAMINATION MARCH 2022
PHYSICS**

DISTRICT INSTITUTE OF EDUCATION AND TRAINING (DIET) PALAKKAD



PHYSICS



പ്രിയ അധ്യാപകരെ,

2021- 22 അധ്യയനവർഷത്തിൽ ഓൺലൈൻ / ഓഫ്ലൈൻ രീതിയിലുള്ള പഠനപ്രവർത്തനങ്ങളാണല്ലോ നടന്നു കൊണ്ടിരിക്കുന്നത്. അതുകൊണ്ടുതന്നെ 2022 മാർച്ചിൽ എസ്.എസ്.എൽ.സി പരീക്ഷ എഴുതുന്ന എല്ലാ കുട്ടികൾക്കും കൂടുതൽ പിന്തുണ അനിവാര്യമാണ്.

2020 ഓഗസ്റ്റ് മുതൽ പാലക്കാട് ഡയറ്റിന്റെ നേതൃത്വത്തിൽ ആരംഭിച്ച INTER-BELL എന്ന ഗവേഷണാത്മക പദ്ധതിയിലൂടെ ഫസ്റ്റ് ബെൽ ഓൺലൈൻ ക്ലാസ്സുകളുടെ തുടർച്ചയായി കുട്ടികൾക്ക് വേണ്ടി തയ്യാറാക്കിയ വർക്ക് ഷീറ്റുകൾ പഠന വിടവ് ഒരു പരിധിവരെ നികത്തിയിരുന്നു എന്ന് നമുക്കറിയാം. എന്നിരുന്നാലും പൊതു പരീക്ഷയെ ആത്മവിശ്വാസത്തോടെ നേരിടാനും സമയബന്ധിതമായി പരീക്ഷ എഴുതാനും കുട്ടികളെ പ്രാപ്തരാക്കേണ്ടതുണ്ട്. അതിനു സഹായകമായ സാമഗ്രികൾ ആണ് ഇതിൽ ഉൾപ്പെടുത്തിയിട്ടുള്ളത്. താരതമ്യേന കുട്ടികൾക്ക് വിഷമം അനുഭവപ്പെടാനുള്ള ഊർജ്ജതന്ത്രത്തിലെ എല്ലാ യൂണിറ്റുകളിൽ നിന്നും ഉള്ള പ്രധാന ചോദ്യങ്ങളുടെ ഒരു ശേഖരമാണ് ഇത്.

ചോദ്യങ്ങളിലൂടെ കുട്ടികളെ ഫലപ്രദമായി കടത്തിവിടാനും പ്രയാസ മേഖലകൾ കണ്ടെത്തി പരിഹാര ബോധനം നടത്താനും അധ്യാപകർ മുൻകയ്യെടുക്കേണ്ടതുണ്ട്. മികച്ച വിജയം കൈവരിക്കാൻ ഈ പഠന വിഭവം ഏവർക്കും സഹായകരമാകട്ടെ എന്ന് ആത്മാർഥമായി ആശംസിക്കുന്നു.

ആനക്കര
15-02-2022

പ്രിൻസിപ്പാൾ
ഡയറ്റ് പാലക്കാട്



UNIT 1 EFFECTS OF ELECTRIC CURRENT

FOCUS AREA

- Energy change in electrical instruments
- Heating effect of electric current, Joule's Law
- Mathematical problems
- Electric power
- Related mathematical problems
- Electric heating instruments
- Peculiarities of substances used as heating coil
- Short circuit
- Overloading, Working of Safety fuse
- Peculiarities of substances used as fuse wire
- Arrangement of resistances – Parallel and series combination, Related problems

ENERGY CHANGES IN THE ELECTRICAL DEVICES

SL NO	DEVICE	USE	ENERGY CHANGE
1	Electric bulb	To get light	Electric energy to Light energy
2	Induction cooker	To get heat	Electric energy to Heat energy
3	Storage battery (while charging)	To store charge	Electric energy to Chemical energy
4	Mixie	For grinding	Electric energy to Mechanical energy
5	Electric Fan	To get wind	Electric energy to Mechanical energy
6	Electric stove	To get heat	Electric energy to Heat energy

The factors influencing the heat developed when a current passes through a conductor.

1. Electric current
2. Resistance of the conductor
3. Time of current flow

JOULE'S LAW: The heat generated (H) in a current carrying conductor is directly proportional to the product of the square of the current (I) in the conductor, the resistance of the conductor (R) and the time (t) of flow of current. $H \propto I^2Rt$

$$\therefore H = I^2 \times R \times t \text{ Joule}$$

I is the current in ampere, R is the resistance in ohm and t is the time in second.

Equations for solving the mathematical problems by using Joule's Law.

$$1. H = I^2 \times R \times t \quad 2. H = V \times I \times t \quad 3. H = \underline{(V^2 \times t)} \quad R$$

Working of a fuse

When the current that flows into the circuit exceeds the permissible limit, the heat generated becomes excessive. Because of its low melting point the fuse wire melts and break the circuit.

Precautions to be taken, while connecting a fuse wire in a circuit.

1. The ends of the fuse wire must be connected firmly at appropriate points.
2. The fuse wire should not project out of the carrier base.
3. Use fuse wire of appropriate amperage.
4. Fuse wire is connected in series.

Arrangement of Resistors

ⓐ **Series Connection** -When a circuit is completed by connecting the resistors one after the other, it is called series connection.

ⓑ **Parallel Connection** -In parallel method the ends of resistors are commonly connecting together at different points.

RESISTORS IN SERIES	RESISTORS IN PARALLEL
1. Effective resistance increases $R = R_1 + R_2$	1. Effective resistance decreases $1/R = 1/R_1 + 1/R_2$
2. The current through each resistor is same as the main current.	2. The current through each resistor is different. It gets divided as per the value of resistors
3. The potential difference across each resistor is different. It gets divided as per the value of resistors.	3. The potential difference across each resistor will be the same
4. Each resistor cannot be controlled by separate switch, because the circuit is broken	4. Each resistor can be controlled by using separate switches.
5. Bulbs of less power glows with more brightness	5. Bulbs of more power glows with more brightness

Electric Power (P)

The amount of energy consumed by an electrical appliance in unit time is its power.

Unit -Watt (W)

1. $P = I^2 \times R$ 2. $P = V \times I$ 3. $P = V^2 / R$ 4. $P = H / t$

Electric heating appliances

Electric heating appliances are instruments that make use of the heating effect of electricity - Electric Iron, Soldering Iron, Electric Heater, Immersion Heater.

Heating Coil.

- ⑩ The part in which electrical energy changes in to heat energy is called the heating coil of an electrical heating appliance.
- ⑩ Nichrome is used as the heating coil. (Alloy of nickel, chromium and Iron)

Peculiarities of Nichrome

1. High resistivity.
2. High melting point.
3. Ability to remain in red hot condition for a long time without getting oxidised.



Safety Fuse

- ⑩ Safety fuse is a device which protects us and the appliances from danger when an excess current flows through the circuit.
- ⑩ Safety fuse is a device that works on the heating effect of electric current.
- ⑩ Fuse wire, an alloy of tin and lead, is the main part of safety fuse. Fuse wire has low melting point.

Circumstances that cause high electric current in a circuit.

Over loading- A circuit is said to be overloaded if the total power of all the appliances connected to it is more than what the circuit can withstand.

Short Circuit -If the positive and the negative terminals of a battery or the two wires from the mains come into contact without the presence of a resistance in between, they are said to be shortcircuited.

Lighting effect of electric current

Incandescent lamps

In normal voltages, the filament becomes white hot and gives out light. Such bulbs are the incandescent (glowing with heat) lamps.

Filament is made with the metal- Tungsten.

Properties of tungsten

1. High resistivity.
2. High melting point.
3. High ductility.
4. Ability to emit white light in the white hot condition.

To avoid the oxidation of the filament – Bulb is evacuated.

Vaporisation of the filament can be reduced by - Filling the bulb with inert gas or nitrogen at low pressure.

Limitations - A major part of the electrical energy supplied to an incandescent lamp is lost as heat. Hence the efficiency of these devices is less.

LED BULB (LIGHT EMITTING DIODE BULB)

- ⑩ As there is no filament, there is no loss of energy in the form of heat.
- ⑩ Since there is no mercury in it, it is not harmful to environment
- ⑩ Very small
- ⑩ It requires only small amount of power.
- ⑩ No filaments.



IMPORTANT QUESTIONS

1. Electric bulb : Electric energy : Light energy (1)
Electric fan : Electrical energy : -----
2. Nichrome : High melting point (1)
Fuse wire : -----
3. Pic the odd one out. (1)
(I^2R , VI , IR^2 , V^2/R)
4. The device which connected parallel in a circuit (1)
(voltmeter, ammeter, galvanometer, watt hour meter)
5. power :: watt (1)
charge :: -----
6. Fuse wire is connected in a circuit (1)
(series / parallel)
7. Safety fuse is a device that works on which principle? (1)
8. Which all situations does the fuse wire melts? (2)
9. Which material is used to make heating coil? (1)
10. Which of the substance given is used as filament? (1)
(Nichrome, Tungsten, Copper, Iron)
11. State joule's law? Write the equation and explain each terms. (3)
12. Calculate the quantity of heat developed in a conductor of resistance 100Ω when $5A$ current passed for 10 minutes. (3)
13. An electric bulb has working $110V$, $100W$ on it,
(a) How much energy is used per second by the circuit? (2)
(b) What is the resistance of the bulb? (1)
14. Why nichrome is not used as filament in incandescent bulb? (2)
15. Which is the part which produce heat in heating appliances? Write any two peculiarities of that substance. (3)
16. Why is the fuse used in circuit called safety fuse? (2)
17. Write precautions to be taken when fuse wire is included in circuit? (3)
18. Why is the bulb filled with an inert gas? (2)

19. Choose the facts related to LED lamps from the given list, (2)

- Requires only a small quantity of power.
- UV rays are produced due to electric discharge.
- Not harmful to environment since there is no mercury.
- Intense light is produced when high voltage is applied.
- Requires only a small quantity of power.
- Not harmful to environment since there is not mercury.

20. Depict a figure showing the arrangement of three resistors in a circuits to get an effective resistance of (4)

(i) 9Ω (ii) 4Ω

21.

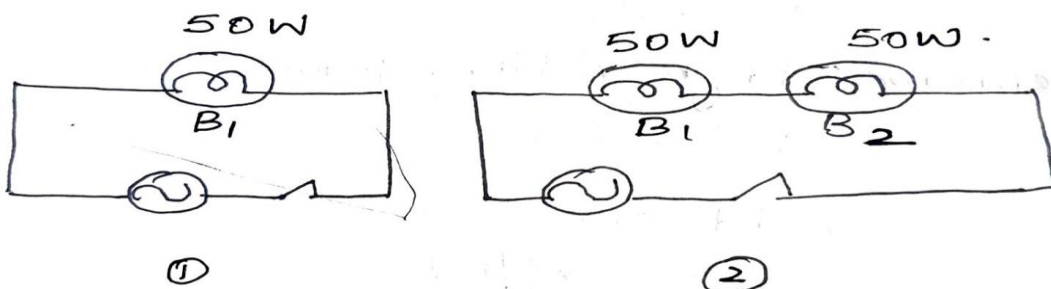

Bulbs marked 200V and 50W are shown in the picture (2+1+1+1)

(a) Calculate the resistance of each bulb in the circuits.

(b) What is the power with which the bulb in the circuit (i) glows

(c) What is the power of the bulb in the circuit (ii)? Why?

(d) How is the power and resistance of an electrical device related to each other when the voltage is the same?

22. When a 12V battery is connected to resistor 2.5 mA current flows through the circuit. If so what is the resistance of the resistor? (2)

23. If a bulb is lit after rejoining the parts of a broken filaments, what will be the change in the power of the bulb? (3)



24. Details of two devices are given below. (2+1+1+1)

Device I		Device II	
Voltage	= 250 V	Voltage	= 250 V
Resistance	= 25 Ω	Resistance	= 50 Ω
Time	= 10 s	Time	= 10 s

- (a) How much will be the heat developed if they are made to work for 10s.
- (b) Why does the device having the low resistance get heated more?
- (c) Find out current in the two devices?
- (d) How do resistors bring about change in the current in the circuit?

DIET PALAKKAD



UNIT-2 MAGNETIC EFFECT OF ELECTRIC CURRENT

FOCUS AREA

- Magnetic field around a current carrying conductor
- Right hand thumb rule
- Magnetic field around a Solenoid
- Magnetic polarity
- Factors effecting the Magnetic field
- Motor principle
- DC motor
- Moving coil loudspeaker- Structure and working.

A magnetic field is developed around a current carrying conductor.

Direction of the magnetic field is from the north pole to the magnet to its south pole.

Magnetic compass is used to identify the presence and direction of the magnetic field.

Direction in which the north pole of the magnetic needle deflects indicates the direction of the magnetic field.

Right Hand Thumb Rule of James Clark Maxwell

- Right hand thumb rule is used to find the direction of the magnetic field formed around a current carrying conductor.
- Imagine you are holding a current carrying conductor with the right hand in such a way, that the thumb points in the direction of the current. The direction in which the other fingers encircle the conductor gives the direction of the magnetic field.

Magnetic field developed around a current carrying straight conductor.

Magnetic field developed around a current carrying straight conductor is the circular shape

When the current is passed from South to North through a conductor

Direction of the magnetic field above the conductor – West to east.

Direction of the magnetic field below the conductor – East to west.



When the current is passed from North to South through a conductor

Direction of the magnetic field above the conductor – East to west.

Direction of the magnetic field below the conductor – West to east.

Magnetic field around a current carrying circular loop

- The end of the coil at which current flows in the clockwise direction -South Pole.
- The end at which current flows in the anticlockwise direction- North Pole.

Solenoid

A solenoid is an insulated conducting wire wound in the shape of helix.

Magnetic field around a current carrying solenoid

- The end of the solenoid at which current flows in the clockwise direction -South Pole
- The end at which current flows in the anticlockwise direction- North Pole

To increase the strength of the magnetic field produced on a solenoid

1. Increase the intensity of the electric current.
2. Increase the no of turns in the solenoid.
3. Use soft iron as the core of the solenoid.
4. Increase the area of cross section of the soft iron core.

Motor principle

A conductor, which can move freely and which is kept in a magnetic field, experiences a force when current passes through it and it move

DC Motor-Working

When electricity is passed through the armature of an electric motor, a force is experienced on the armature and it rotates its axis based on Fleming's left hand rule

Split ring commutator helps to change the direction of current through the armature after every half rotation.

Energy Change – Electrical energy is converted to mechanical energy.

Working principle – Motor principle.

Moving coil loud speaker- Working

- The electrical pulses from a microphone are strengthened using an amplifier and sent through the voice coil of a loudspeaker. The voice coil, which is placed in the magnetic field, moves to and fro rapidly, in accordance with the electrical pulses. These movements make the diaphragm vibrate, thereby reproducing sound.
- Energy Change – Electrical energy is converted to sound energy.
- Working principle – Motor principle.

IMPORTANT QUESTIONS

1. Magnet which is created due to the flow of current through the coils in it is called (1)
2. Insulated wire wound in the shape of a helix is called (1)
3. The end of the solenoid at which current flows in clockwise direction (1)
4. Which effect of electric current is used in Electric fan? (1)
5. In devices like fan, mixie etc which principle is working (1)
6. The direction of magnetic field is shown in the figure PQ a current carrying conductor. (1)

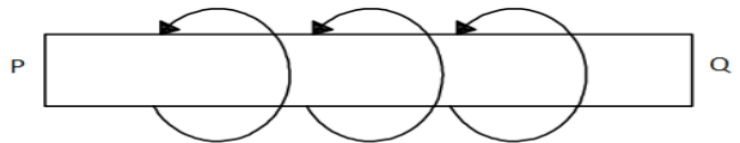

- a. Write down the direction of electricity (1)
(From P to Q / From Q to P)
- b. Which Law is used here? (1)

7. A conductor is arranged as shown in the figure. Draw the magnetic flux lines around P & Q (2)

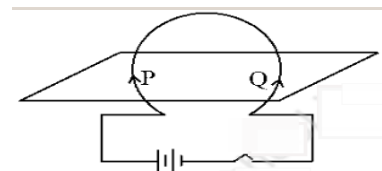

8. Compare the magnetic fields of a Solenoid and Bar magnet and tabulate them. (2)
9. The current at the end A of the solenoid is in anti-clock wise direction.

- a. What will be the pole here? (1)
- b. Write down two methods to increase the magnetic strength of this solenoid (2)

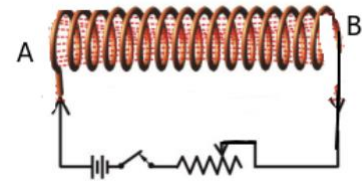

10. a. Name the instrument shown in the figure (1)
- b. Write down the energy change occurs (1)
- c. While switched on, what will be the direction of motion of AB of the armature (Moves upward/ Moves downward) (1)
- d. Name the Law used here (1)

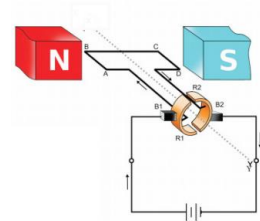

11. A picture of Moving coil loudspeaker is given.

- a. Name the parts a, b & c (3)
- b. Write down the energy change (1)
- c. Write down its working principle (1)

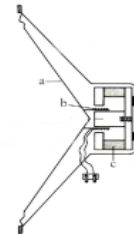

DIET PALAKKAD



UNIT - 3 ELECTROMAGNETIC INDUCTION

FOCUS AREA

- Electromagnetic induction
- Factors effecting induced emf
- Current from AC generator, DC generator and cell- Characteristics and graphical representation
- AC and DC generator-Structure and working
- Mutual induction
- Transformers- Structure
- Moving coil microphone
- Power transmission in high voltage
- Electric shock-first aid.

Electromagnetic Induction.

Whenever there is a change in the magnetic flux linked with a coil, an emf is induced in the coil. This phenomenon is electromagnetic induction.

Methods to increase the induced emf produced in a solenoid due to electromagnetic induction

1. Increase the strength of the magnet.
2. Increase the number of turns in the solenoid.
3. Increase the speed of motion.

Characteristics of electricity received from an AC generator

- Direction changes continuously
- emf increases and decreases

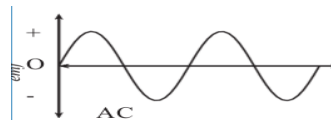

Similarities

- ⑩ Armature and field magnet are used in both.
- ⑩ Both works based on the principle of electro magnetic induction.
- ⑩ AC is induced in the armature in both cases.



AC Generator-Working

- Rotates the armature or field magnet by using mechanical energy. Magnetic flux change is taking place, and an emf is induced on the armature coil due to electromagnetic induction. The electricity produced on the armature coil, reaches the external circuit through the slip rings and brushes.
- After every half rotation, direction of current in the armature coil and the external circuit is reversed.
- Working principle – Electromagnetic Induction
- Energy change – Mechanical energy is converted to electrical energy. Instances at which maximum emf is induced on the armature - When the plane of the armature coil becomes parallel to the magnetic field (90° , 270°)

DC Generator-Working

- Rotates the armature, by using mechanical energy. Magnetic flux change is taking place, and an emf is induced on the armature coil due to electromagnetic induction. The electricity produced on the armature coil, reaches the external circuit through the slip rings and brushes.
- After every half rotation, direction of current in the armature coil is reversed.
- Contact between the split rings and brushes are interchanged after every half rotation.

Hence, in the external circuit electricity is always flows in the same direction.

AC Generator	DC Generator
Slip rings are used.	Split rings are used
AC in the external circuit.	DC in the external circuit

Self Induction

The change in magnetic flux due to the flow of an AC in a solenoid will generate a back emf in the same solenoid in a direction opposite to that applied to it. This phenomenon is known as the self induction.

- Due to self induction, the effective voltage in the circuit is decreases. Hence the intensity of bulb in the circuit is also decreases.

For self induction,

- Supply current must be AC.



- A solenoid must be included in the circuit

Methods to increase self induction (back emf)

1. Use solenoids, having more turns in it.
2. A soft iron core is placed inside the solenoid.
3. Increase the area of cross section (Thickness) of the soft iron core.

Mutual induction

Consider two coils of wire kept side by side. When the strength or direction of the current in one coil changes, the magnetic flux around it changes. As a result, an emf is induced in the secondary coil. This phenomenon is the mutual induction.

- The coil into which we give current for the production of magnetic field – Primary coil(input coil)
- The coil in which induced emf is generated - Secondary coil (output coil)

Transformer

Transformer is a device for increasing or decreasing the voltage of an AC without any change in the electric power.

- Transformer which increases AC voltage - step up transformer.
- Transformer which decreases AC voltage -step down transformer.

Working

When AC is given to the primary coil of a transformer, a varying magnetic field is produced around it. As a result an emf is induced on the secondary coil, which is situated on the same magnetic field. The emf induced on the secondary coil is proportional to the number of turns on it.

Working principle – Mutual Induction (Electromagnetic induction)

Step up transformer	Step down transformer
Number of turns in the primary coil is lesser than Secondary coil	Number of turns in the primary coil is greater than Secondary coil.
Output voltage is greater than input voltage.	Input voltage is greater than output voltage
Thickness of primary coil is greater than secondary coil.	Thickness of secondary coil is greater than primary coil,
Input current is greater than output current.	Output current is greater than input current.



Moving coil microphone.

The voice coil is situated in a magnetic field. The diaphragm connected to the voice coil vibrates in accordance with the sound waves falling on it. As a result, electrical signals corresponding to the sound waves are generated in the voice coil

- Energy change - Sound energy is converted to electrical energy.
- Working principle – Electromagnetic induction.

Power transmission

- When electricity is transmitted to distant places, there is loss of energy in the conductors in the form of heat. This is known as transmission loss.
- Voltage drop and transmission loss are the problems we encountered, when power is transmitted to distant places.
- Electricity is generated at the power station at 11 KV voltage.
- The voltage is increased up to 220 kV at the power station itself. As a result the current and loss of energy in the form of heat decreases.
- The voltage is lowered at different stages of power transmission and electricity is made available to the distribution transformer at 11 kV.
- 230 V required for house hold purposes is made available by distribution transformers. 400V needed for industrial purposes are also obtained from distribution transformers.

Precautions for avoiding electric shock

1. Never handle electric equipments or operate switches when the hands are wet.
2. Insert plug pins into socket and withdraw them only after switching off.
3. Wear rubber footwear while operating electric devices.
4. Do not fly kites near electric lines.
5. Do not use table fan to dry hair.

First aid to the person, who gets electric shock.

1. Raise the temperature of the body by massaging.
2. Give artificial respiration.
3. Massage the muscles and bring them to the original condition.
4. Start first aid for the functioning of the heart. (Apply pressure on the chest regularly)
5. Take the person to the nearest hospital immediately.

IMPORTANT QUESTIONS

Question number 1 to 15 one mark each

1. Observe the relation of given pair and fill in the blanks.
 - a) Generator: Armature
Moving coil microphone:
 - b) Transformer: Mutual induction
Generator:
2. Find the odd one
(Microphone, Transformer, Loudspeaker, Generator)
3. Consecutive currents flowing in the same direction
4. What is the advantage of rotating the field magnet instead of armature in AC generators?
5. The configuration used to convert an AC generator to a DC generator
6. If the power of the primary coil of a transformer is 500 W, what is the power of the secondary coil?
7. What is the voltage for household connection
8. In the household electrical circuit on which line the fuse is attached?
9. As a result of electric shock the viscosity of the blood of the victim..... (increasing / decreasing)
10. In a step-up transformer considering there is no power loss, the current in the primary is greater than / equal to / equal to that of the secondary.
11. The working principle of moving coil microphone is
12. What are the characteristics of electric power generated in our country?
13. Which type of transformer is a distribution transformer ?
14. What is the Commercial unit of Electricity?
15. Which device is used in the place of safety fuse in household branch circuits ?

16. a) State the law relating to the phenomenon the figure (1)
b) What are the factors influencing the induced emf? (2)

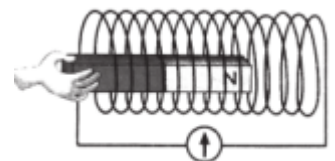

- 17.a) Identify the given generator (AC / DC) (1)
- b) Mark the parts. (NS. ABCD R1, R2 B1, B2) (1)
- c) Draw a graphical representation of the emf available from the generator (1)
- d) What is the law that helps in finding the direction of induced emf (1)

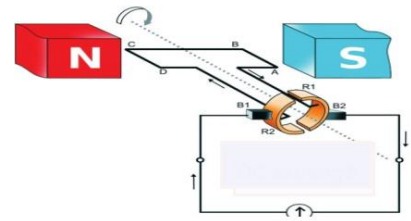

18 .Complete the table (3)

Source	graph of emf	Characteristics
AC generator		
DC generator		
Battery / cell		

19 Analyse the graph and answer the following questions (3)

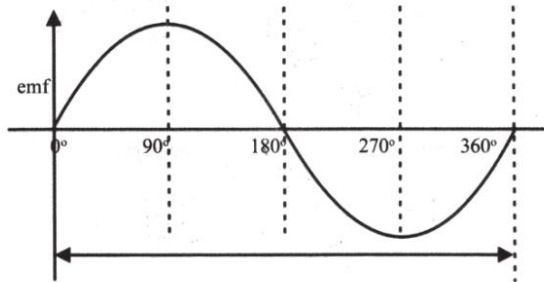

- a) The angles at which the rate of change of flux is maximal 1
- b) Why does the emf maximum at these angles
- c) The angles at which the rate of change of flux is zero

20. The diagram of a two phases of the rotation of the armature of a generator in a magnetic field is given.

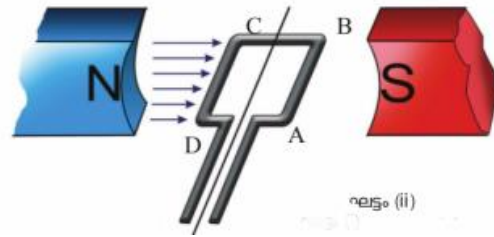
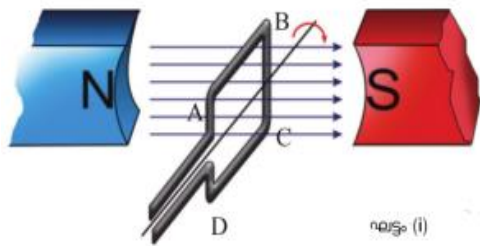

- a) In which figure the surface of the armature coil is parallel to the magnetic field (1)
- b) At what stage does maximum emf occur (1)

21. The figure shows the mutual induction phenomenon.

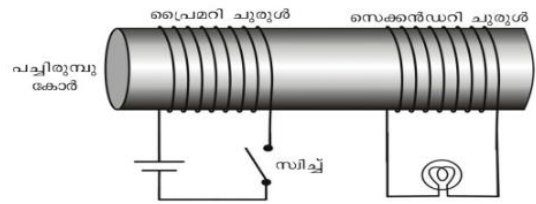

- a) What happens when the switch is turned on? (1)
- b) What happens if I turn it off? (1)
- c) What happens if the switch is kept in on position? Why? (2)

22.

- a) Which type of transformer is shown in Figure (1)
- b) Write the working principle (1)
- c) There are 50 turns in the primary and 500 turns in the secondary of this transformer. If 120 V is applied to the primary, calculate the secondary voltage (2)

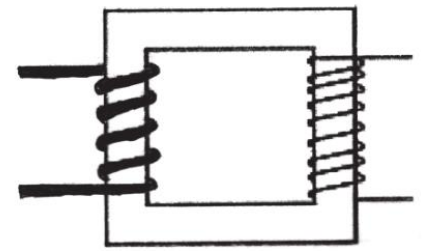

A

23 In the following experiment

- a) What is the change in light intensity of the bulb when the switch is turned on? (1)
- b) What causes the light intensity to decrease when the iron core is placed inside the coil (1)
- c) Name this phenomena (1)

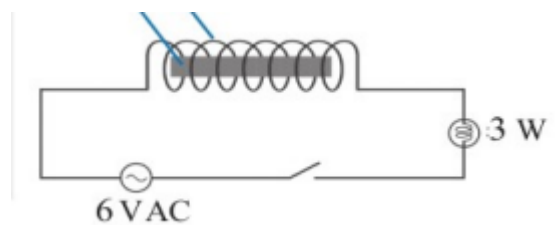

24

- a) Identify A and B in Figure (1)
- b) How to convert sound energy into electrical energy in this device (1)

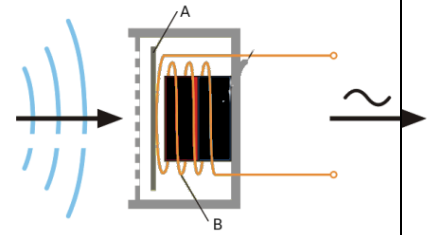

25

- a) What is the main problem faced in power transmission? (1)
- b) Why is the voltage increased before transmission? (1)

26 a) What are the precautions to be taken to avoid electric shock? (2)

b) What is the first aid given in case of electric shock? (2)

27 What are the ways to ensure safety in household power supply (2)

DIET PALAKKAD

UNIT 4-REFLECTION OF LIGHT

FOCUS AREA

- Reflection
- Laws of reflection
- Characters of image formed in concave mirror and convex mirror
- Mirror equation, magnification and related problems
- New cartesian sign convention

LAWS OF REFLECTION

1. When light is reflected from a smooth surface, the angle of incidence and angle of reflection are equal
2. The incident ray, reflected ray and normal to the surface are in the same plane.

Plane mirror	Convex mirror	Concave mirror	
		Position of object	Position of image and features
Image is behind the mirror. Distance of object from the mirror and distance of the image from the mirror are equal. The image is virtual, erect and is of the same size as that of the object.	Image is formed in between the pole of the mirror and the principal focus. The image is diminished, virtual and erect.	At infinity	At focus, small, real, inverted
		Beyond C	Between F and C small, real, inverted
		At C	At C, same size, real, inverted
		Between C and F	Beyond C, big, real, inverted
		At F	At infinity
		Between F and P	Behind the mirror, big, virtual, erect

Concave mirror	Convex mirror
Real images and virtual image are formed	Only virtual images are formed.
Magnified image, diminished image and same size images are formed.	Only diminished images are formed.
Real images are formed in front of the mirror and virtual image is formed behind the mirror.	Images are always formed behind the mirror.
Position and nature of the images are changed, with the change of position of the object.	Whatever be the position of the object, the image is always formed behind the mirror between P and F.

If 'f' is the focal length of the mirror, 'u' is the distance from the object to the mirror and 'v' is the distance from the image to the mirror, then,

$$1/f = 1/u + 1/v$$

Equations for solving mathematical problems

1. $f = uv / (u+v)$
2. $v = uf / (u-f)$
3. $u = vf / (v-f)$

New Cartesian Sign Convention

- Distances are measured considering the Pole of the mirror as the origin
- Those measured to the right from O are positive and those in the opposite direction are negative.
- Distances measured upwards from X axis are positive and those downwards are negative.
The incident ray is to be considered as travelling from left to right.



PHYSICS



	Concave mirror		Convex mirror
	Real	Virtual	Virtual
u	negative	negative	negative
v	negative	positive	positive
R	negative	negative	positive
f	negative	negative	positive
h _i	negative	positive	positive
h _o	positive	positive	positive
m	negative	positive	positive

Magnification

- Magnification is the ratio of height of the image to the height of the object
- Magnification (m) = Height of the image / Height of the object = $m = h_i / h_o = -(v/u)$
- When the magnification is positive, image is virtual and erect.
- When the magnification is negative, image is real and inverted
- When magnification is 1, the size of the image and the size of the object are equal.
- When magnification is more than 1, the size of the image is greater than the size of the object.
- When magnification is less than 1, the size of the image is smaller than the size of the object.

IMPORTANT QUESTIONS

EACH QUESTIONS CARRIES ONE MARK

- Fill in the blanks by finding the suitable relations
 - Shaving mirror : Concave Mirror
 - Rear view mirror :
 - Real image : Convex mirror
 - Virtual image :
- Identify the mirror which converges distant rays to the principal focus.
- Identify the mirror which reflects the rays coming from principal focus as parallel rays.



4. Arrange two plane mirrors in such a way that their edges are in contact. Place a burning candle in between them. Find out the number of images if the angle between the mirrors is 90° ?
5. When magnification is 1, what is the size of the image formed?
6. When magnification is more than 1, what is the size of the image formed?
7. When magnification is less than 1, what is the size of the image formed?
8. When the magnification is positive, what is the nature of the image?
9. When the magnification is negative, what is the nature of the image?
10. What is the unit of power of a mirror?

EACH QUESTIONS CARRIES TWO MARKS

11. An illuminated object is placed in front of a spherical mirror of focal length 20cm, a real image of same size is formed.
 - A. Write the position of the image.
 - B. Write the size of the image
12. Write the Laws of Reflection
13. Write the difference between the principal focus of a convex mirror and concave mirror.
14. Why convex mirrors are used as rear view mirrors?
15. Why concave mirrors are used by dentists?

EACH QUESTIONS CARRIES THREE MARKS

16. "Objects in the mirror are closer than they appear" Why is it written in rear view mirror of vehicles?
17. An object is placed in front of a concave mirror 20 cm away from it. If its focal length is 40 cm, locate the position of image and its nature.
18. Wrap a rubber ball of diameter 12 cm completely with an aluminium foil and make the surfaces smooth.
 - A. Where will be the image of an object kept 12 cm away from the centre of the ball?
 - B. Is the image real or virtual?

EACH QUESTIONS CARRIES FOUR MARKS

19. When an object of height 6 cm is placed in front of a concave mirror at a distance 10 cm away from it, an image is obtained 16 cm away, on the same side. Find out the height of image and magnification.
20. A dental doctor uses a mirror of focal length 8 cm. To see the teeth clearly what should be the maximum distance between the teeth and the mirror? Justify your answer.
Which type of mirror has been used by the doctor?

UNIT- 5 REFRACTION OF LIGHT

FOCUS AREA

- Refraction, Relation between optical density and speed of light
- Refraction in different medium (figure)
- Critical angle
- Total internal reflection
- Lens technical terms – complete
- Image formation, ray diagrams, characters of image
- Power of lens

Refraction of light

When a ray of light enters obliquely from one transparent medium to another, its path undergoes a deviation at the surface of separation. This is refraction. It is the difference in the optical densities that causes the refraction.

As the optical density of a medium increases, the speed of light through it decreases.

Refraction through the glass slab

When light travels from air to glass (travel from a medium of lower optical density to a medium of higher optical density) - Refracted ray deviates towards the normal.

When light travels from glass to air (travel from a medium of higher optical density to a medium of lower optical density) - Refracted ray deviates away from the normal.

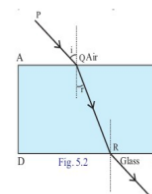

Optical density

Optical density is a measure that shows how a medium influences the speed of light passing through it.

As the optical density of a medium increases, the speed of light through it decreases.

As the optical density of a medium decreases, the speed of light through it increases.

Critical angle .

When a ray of light passes from a medium of greater optical density to that of lower optical density, the angle of incidence at which the angle of refraction becomes 90° is the critical angle. The critical angle in water is 48.6° .



Total internal reflection.

When a ray of light passes from a medium of higher optical density to a medium of lower optical density at an angle of incidence greater than the critical angle, the ray is reflected back to the same medium without undergoing refraction. This phenomenon is known as total internal reflection.

Conditions for total internal reflection

- Light ray should travel from a medium of higher optical density to a medium of lower optical density.
- Angle of incidence should be greater than critical angle.
- Practical applications of total internal reflection in our day to day life
- Medical field → Endoscope.
- In the field of telecommunications → Optical fibre cables.

Lenses

- A lens is a transparent medium having spherical surfaces.
- Convex and concave lenses are the lenses that we mainly use.

Terms associated with lenses

- Optic centre is the midpoint of a lens (P).
- Centre of curvature (C) is the centre of the imaginary spheres of which the sides of the lens are parts.
- Principal axis is the imaginary line that passes through the optic centre joining the two centres of curvature.
- Light rays incident parallel and close to the principal axis after refraction converges to a point on the principal axis of a convex lens. This point is the principal focus of a convex lens.
- Light rays incident parallel and close to the principal axis diverge from one another after refraction. These rays appear to originate from a point on the same side. This point is the principal focus of a concave lens.

Image formed by concave lens

In a concave lens whatever may be the position of the object, the image is always formed at the same side of the object, in between the optic centre (P) and focus(F). The image is virtual, erect and diminished.

Position of object	Position of image	Nature of image/ size		
		Real/ virtual	Inverted/ erect	Magnified/ diminished/ same size
1. At infinity	At F	Real	Inverted	diminished
2. Beyond 2 F	Between 2F and F on other side.	Real	Inverted	diminished
3. At 2 F	At 2F on other side.	Real	Inverted	same size
4. Between 2F and F	Beyond 2F on other side.	Real	Inverted	diminished
5. At F	At infinity			
6. Between F and lens	Same side of the object	virtual	erect	Magnified

Comparison of images formed by a convex lens and a concave lens

Convex lens	Concave lens
Real images and virtual image are formed	Only virtual images are formed.
Magnified image, diminished image and same size images are formed.	Only diminished images are formed.
Position and nature of the images are changed, with the change of position of the object.	Whatever may be the position of the object, the image is always formed at the same side of the object, in between the optic centre (P) and focus(F)
Real images are formed on the other side of the lens and virtual image is formed at the same side of the object.	Virtual Images are always formed at the same of the object.

Power of a lens

- Power of a lens is the reciprocal of focal length expressed in metres. ($p=1/f$)
- Unit of power is dioptre. It is represented by D
- Power of a Convex lens – Positive.
- Power of a Concave lens – Negative

IMPORTANT QUESTIONS

SECTION A (1 MARK EACH)

- 1) Identify the medium in which light travels with highest velocity?
(Air, water, glass, diamond)
- 2) Which among the following have highest optical density?
(air, glass, diamond, water)
- 3) A pencil immersed in water appear to be broken at the surface of separation of media, why?
- 4) Name the Phenomenon of light utilised in optic fibre cables.
- 5) The unit of power of lens is _____
- 6) Stars appears to be glittering, why?
- 7) In a lens it is labelled as +2D, identify the lens.
- 8) If magnification is positive the nature of image formed will be _____
- 9) Name the lens which always form virtual and diminished image
- 10) Name the lens which can form virtual and enlarged image
- 11) Identify the correct figure showing total internal reflection from the following

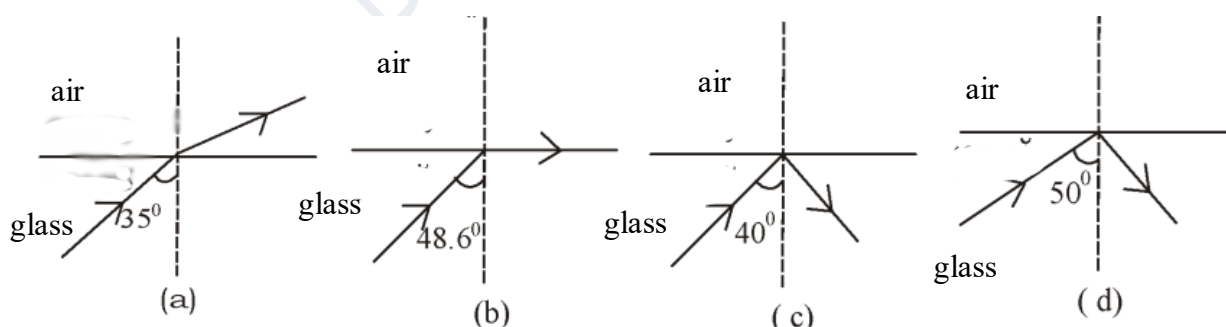

- 12) Find the relation and complete the pair

Mirror: Reflection

Lens : _____

- 13) Name the phenemenon of light used in endoscope

(Refraction, reflection, dispersion, total internal reflection)

14) If an object is placed at $2F$ of a convex lens, what will be its magnification?

(less than 1, greater than 1, 0, 1)

15) Complete the following figure and label the principal focus

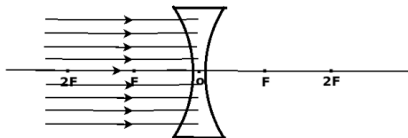

16) Find the relation and complete the pair

Focal length : meter

Power of lens: _____

17) The focal length of a convex lens is 500cm, calculate its power?

18) The image of an object at infinity will be formed at _____ of convex lens.

19) Arrange the following in the ascending order of optical density

(diamond, air, water, glass)

20) At which position should be the object placed in order to get same sized image?

21) Name the lens which always form virtual image.

22) Complete the following figure and label the principal focus

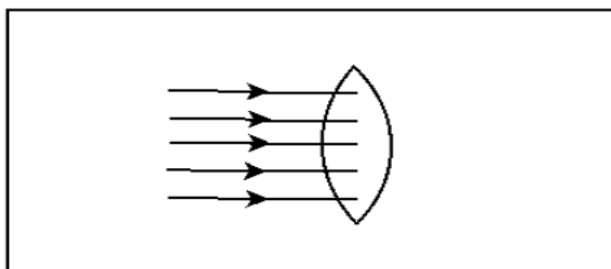

23) When a ray of light passes obliquely from one medium to another, its path undergo deviation, this phenomenon is known as _____

SECTION C (3 MARKS EACH)

1)

Medium	Refractive index
Air	1.0003
Water	1.33
Kerosene	1.44
diamond	2.42

- a) Find the medium having highest optical density
 - b) Will the ray of light deviate towards normal or away from normal when it enters from water to diamond obliquely?
 - c) What is the relation between speed of light and refractive index?
- 2) While doing an experiment with convex lens a diminished image is formed
- a) What will be the nature of image formed (real/ virtual)
 - b) Identify the position of image?
 - c) According to new cartesian sign convention, the focal length of lens will be _____ (positive/ negative)

3) Observe the ray diagram

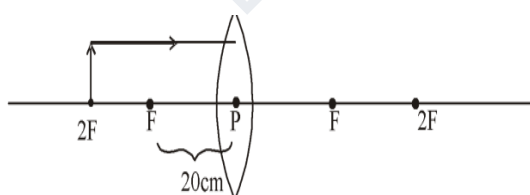

- a) Redraw the diagram and complete it to get the image
 - b) Calculate the magnification of image formed by this lens
 - c) What is the power of this lens?
- 4) Observe the following diagram and answer the following questions

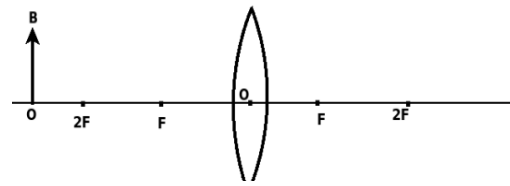

- a) Identify the lens used
 - b) Complete the ray diagram and find the position of image formed
 - c) Write any two characteristics of the image formed

- 5) Statements related to lens are given, tabulate them to real and virtual images
 - a) Inverted
 - b) cannot be captured on screen
 - c) can be captured on a screen
 - d) image formed when actual intersection of light rays occur
 - e) erect
 - f) magnification will be negative

- 6) The image of an object is produced on a screen using convex lens. Find the position of the object in each of the following conditions.
 - a) Obtains an image of size equal to the object
 - b) Obtains an image smaller than object
 - c) Obtains an real image bigger than the object.

- 7) The terms given are related to lens are given, define them
(Focal length, Principal axis, Centre of curvature)

- 8) Find the measures based on new cartesian sign convention

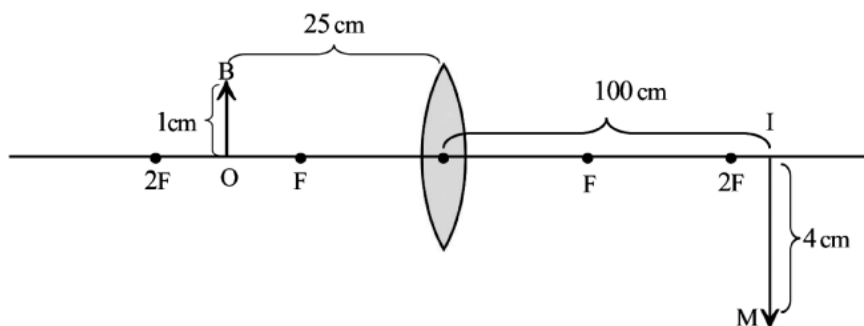

- a) Object distance (u) :
- b) Image distance (v) :
- c) Height of the object :
- d) Height of image :
- e) Focal length of lens (f):
- f) magnification of image :

9) An object of height 2cm having a focal length 15 cm is placed at a distance of 20cm from a convex lens.

- a) Find distance of image
- b) What Will be the nature of image
- c) What is the height of image.

10) An object OB is placed in front of a lens MN

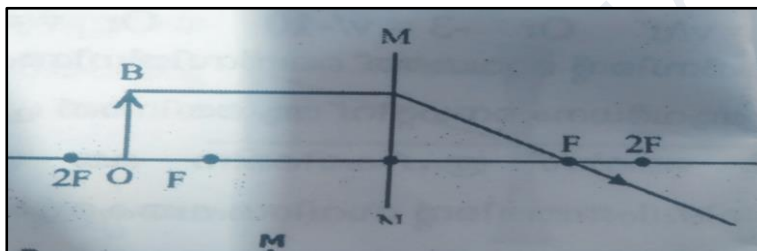

- a) Identity the type of lens
- b) Complete the ray diagram
- c) Write any 2 features of image formed.

11) Analyse the following figure and answer the questions given below

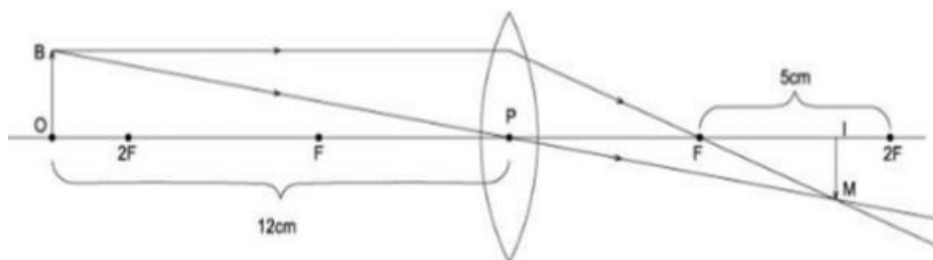



PHYSICS



- a. What is the focal length of the lens ? (1)
- b. Write the value of 'u' in the figure , including sign ? (1)
- c. Is the value of ' v ' positive or negative. Why ? (1)
- d. Calculate the distance to the image?(1)

12) Some light conducting medium are given in the bracket

[Vacuum, Diamond, Water, Glass]

- a) Which is of greater optical density ? (1)
 - b) Arrange the media in the decreasing order of the speed of light(2)
 - c) What is the relation between optical density and speed of light (1)
- 13) a) What are the conditions for reflection of light ray AB in the direction BC (1)
- b) What is the phenomenon called ? (1)
 - c) Write the practical application of this phenomenon in our daily life (1)
 - d) If angle of incident is 42° what is the angle of refraction at that time ?(1)
 - e) If angle of incidence is 35° what are the phenomenon take place here (1)

UNIT 6 VISION AND THE WORLD OF COLOURS

FOCUS AREA

- Short sightedness
- Long sightedness – Reasons and Remedies
- Dispersion
- Rainbow, Scattering of light, relation between wavelength of colours and scattering
- Reason for red Colour of the rising and the setting sun

Hypermetropia or Long-sightedness

- Since the image is not formed at the retina, instead of being formed at the retina, nearer objects cannot be seen clearly even though distant objects are clearly seen. This defect of the eye is the long sightedness.
- The image of nearer object is formed behind the retina.
- The near point of the eye of such a person will be at a distance of more than 25 cm.

Reasons for Hypermetropia.

- Size of the eyeball is smaller.
- Power of the eye lens is less. (Focal length is high)

Remedy for Hypermetropia.

- Using convex lens of suitable power.

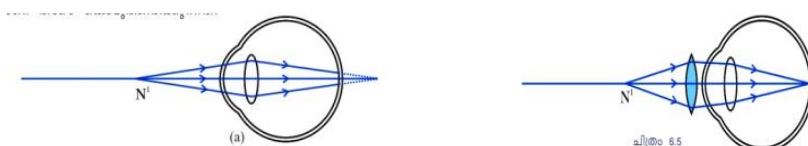

Myopia or Near-sightedness

- For some persons, even though nearby objects can be seen clearly, they may not be able to see distant objects clearly. This defect is the near sightedness.

- The image of distant object is formed in front of the retina.
- The near point of such persons will not be at infinity.

Reasons for Near-sightedness

- Size of the eyeball is larger.
- Power of the eye lens is high. (Focal length is less)

Remedy for Near-sightedness

- Using concave lens of suitable power.



Dispersion of light

- Any light that is composed of more than one colour is a composite light.
- Dispersion is the phenomenon of splitting up of a composite light into its constituent colours
- Any light that is composed of more than one colour is a composite light.
- The regular array of colours formed by dispersion is the visible spectrum.
- Light rays of shortest wavelength(violet)- Deviates more.
- Light rays of longest wavelength (red)- Deviates less.

Reason for dispersion

Light undergoes refraction when it enters the prism obliquely and when it comes out of the prism. The extent of deviation depends on the wavelength. Therefore waves undergo deviation at different angles and get separated. This is the reason for dispersion.

Dispersion through glass prism

- ⑩ Colour seen nearer to the base of the prism -Violet.
- ⑩ Colour seen far away from the base – Red.
- ⑩ Order of colours from the base -Violet, Indigo, Blue, Green, Yellow, Orange, Red. (VIBGYOR)



Fig. 6.9

Rainbow

- Dispersion of light caused by the water droplets in the atmosphere causes rainbow.
- In the morning rainbow is seen- West.



- In the evening rainbow is seen – East.
- Sunlight passes through the water droplets in the atmosphere refracted twice, and has one internal reflection also.
- Colour seen at the upper edge of the rainbow –Red.
- Colour seen at the lower edge of the rainbow- Violet.
- The light ray emerging from the water droplets which make the same angle with the line of vision have the same colour. These droplets appear in the form of an arc of a particular colour.
- When seen from an aeroplane, the rainbow is seen as a circle.

Persistence of vision

When an object is viewed by a person, its image remains in the retina of the eye for a time interval of 0.0625s (1/16 s) after seeing it. This phenomenon is called persistence of vision. If more than one scene is viewed within 0.0625s, the effect of all these scenes will be felt by the eye simultaneously.

Examples of persistence of vision -

- Newton's colour disc appears white, when it rotated fast.
- A torch rotated rapidly appears as an illuminated circle.
- Raindrops appears like a glass rod.
- A fan appears like a disc, when it rotates fast.

Scattering of light

- Scattering is the change in direction brought out by the irregular and partial reflection of light when it hits the particles of the medium.
- Light rays of shortest wavelength – Scattered more.
- Light rays of longest wavelength- Scattered less.
- Sky appears blue- Colours like violet, indigo and blue have the smallest wavelengths in sunlight. They undergo maximum scattering while interacting with atmosphere particles
- Sun and horizon appears red during sunset and sunrise. - During sunrise and sunset, light reaching us from the horizon has to travel long distances through the atmosphere. During this long journey, colours of shorter wavelength would be almost fully lost due to



scattering. Then, the red light which undergoes only less amount of scattering decides the colour of the horizon.

- As the size of the particle increases, the rate of scattering also increases.
- If the size of the particles is greater than the wavelength of light, then the scattering is same for all colours. (Sky in the cities appears grey)
- Red colour has been given to the tail lamps of vehicles and signal lights – Because of its higher wavelength, red can travel long distances without scattering.

IMPORTANT QUESTIONS

1. Which colour deviates the most due to dispersion?
2. Which colour deviates the least due to dispersion?
3. What is the colour seen at the upper edge of the rainbow?
4. What is the colour seen at the lower edge of the rainbow?
5. How is rainbow seen from an aeroplane?
6. How many times does a ray of light undergo refraction when it passes through a water droplet?
7. How many times does a ray of light undergo internal reflection when it passes through a water droplet?
8. What is the unit of Power of a Lens?
9. What is Presbyopia?
10. What is the power of accommodation ?
11.
 - a) What is Hypermetropia or Long-sightedness?
 - b) What are the reasons for Hypermetropia or Long-sightedness?
 - c) How can it be solved?
12.
 - a) What is Myopia or Near-sightedness?
 - b) What are the reasons for Myopia or Near-sightedness?
 - c) How can it be solved?
13. When a person suffering from problem in vision met a doctor, he wrote in his prescription the following figures. +1.5 D, -2D.
 - a) What has the doctor indicated in the prescription?
 - b) Which are the types of lenses prescribed here?



PHYSICS



14. Give reasons for the following

- a) A torch rotated rapidly appears as an illuminated circle.
- b) The sun appears red during sunset and sunrise.
- c) Sky appears to be blue in colour.

15. The use of light in excess in a non - judicious manner is referred to as light pollution.

- a) What will be the consequences of light pollution?
- b) Write what can be done to minimize the light pollution.

16. What is Tyndal Effect ?

17. What is Scattering of light?

18. What is Persistence of vision?

DIET PALAKKAD



UNIT 7 – ENERGY MANAGEMENT

Fuels:

Fuels are substances that release plenty of heat energy on burning.

The properties that a good fuel :

- Should be easily available.
- Should be of low cost.
- Should have a high calorific value.
- Should cause minimum atmospheric pollution on combustion.
- Should be easily storable.
- A liquid fuel must not evaporate quickly at ordinary temperatures.

Complete Combustion :

Complete combustion is a reaction in which fuels react intensively with oxygen, producing carbon dioxide, steam, heat and light.

Conditions favourable for the complete combustion.

- ⑩ Sufficient oxygen must be available for burning.
- ⑩ The solid fuels must be dry.
- ⑩ The ignition temperature should be attained.
- ⑩ Liquid fuels must evaporate easily.

Features of complete combustion

- ⑩ Carbon monoxide is not formed.
- ⑩ More heat is generated.
- ⑩ Soot is not formed.
- ⑩ Less smoke is formed.
- ⑩ Fuel loss is less.

Partial combustion:

If oxygen is not sufficient, large quantities of carbon monoxide, soot and a little of carbon dioxide will be formed. This type of burning is partial combustion.

Features of Partial combustion

- ⑩ Carbon monoxide is formed.
- ⑩ Soot and smoke are formed.



- ⑩ Rate of combustion will be less.
- ⑩ Causes atmospheric pollution
- ⑩ .Loss of fuel.

Fossil fuels :

Fossil fuels are formed by the transformation of plants and animals that went under the earth's crust millions of years ago. The transformation took place in the absence of air under high pressure and high temperature.

- ⑩ Coal, petroleum and natural gases are fossil fuels.
- ⑩ They are not replenished or renewed in proportion to their consumption. Hence they are non-renewable energy sources.

Coal

- ⑩ Coal is the most abundant fossil fuel on the earth.
- ⑩ The main component of coal is carbon.
- ⑩ Based on the carbon content, coal is classified into four groups as peat, lignite, anthracite and bituminous coal.
- ⑩ When coal is distilled in the absence of air, the substances obtained are ammonia, coal gas, coal tar, coke.

C. N. G (Compressed Natural Gas), L. N. G (Liquefied Natural Gas)

- ⑩ Obtained from the natural gas. Main component is methane.
- ⑩ used as fuels in vehicles, industries and thermal power stations
- ⑩ Importance of L. N. G -natural gas can be liquefied and transported to distant places conveniently

L. P. G (Liquefied Petroleum Gas)

- ⑩ obtained through the fractional distillation of petroleum
- ⑩ Main component is butane.
- ⑩ colourless, odourless gas

L P G and Safety

- ⑩ Ethyl mercaptan is added as an indicator to detect gas leakage
- ⑩ Never switch on or switch off electricity when there is a leakage of LPG – Sparking causes fire.



- ⑩ If there is leakage of LPG it is mandatory to open the doors and windows -LPG is denser than air, so they seen at the bottom of the atmosphere.
- ⑩ Examine the rubber tube at regular intervals and ensure that it does not have a leakage.
- ⑩ Turn on the knob of stove only after the regulator is turned on.
- ⑩ Ensure that the expiry date of the cylinder is not over.
- ⑩ The expiry date of a cylinder is 2024 march 31, if it is marked as A24
- ⑩ Disconnect electricity from outside.
- ⑩ Switch off the regulator and shift the cylinder to an empty space.
- ⑩ Keep the windows and doors open.
- ⑩ Well trained rescue operators can put out the fire by covering the top end of the cylinder with wet sack to prevent the contact with oxygen

Green energy is the energy produced from natural sources that does not cause environmental pollution. All the energy produced from renewable sources belong to this category

.Eg: Solar cell, Tidal Energy, Hydro electric power, Wind mills.

Brown energy is the energy produced from non renewable sources such as petroleum and coal, and the nuclear energy .Brown Energy cause environmental problems including global warming.

Eg: Atomic reactors, Diesel engines, Thermal power station. Coal

Energy crisis is the consequence of increasing demand but decreasing availability.

Reasons for energy crisis

- ⑩ Energy is wasting.
- ⑩ Excess usage of non renewable sources of energy.
- ⑩ Industrialisation
- ⑩ Population growth.

Solutions for energy crisis

- ⑩ Judicious utilisation of energy.
- ⑩ Maximum utilisation of solar energy.
- ⑩ Making use of public transportation as far as possible.
- ⑩ Timely maintenance of machines.



IMPORTANT QUESTIONS

- Pick the odd one out
(coal, petroleum, natural gas, biogas)
- Which process is taking place in atom bomb?
- Which fuel is used in nuclear reactors?
- Which principle is used in making hydrogen bomb?
- Name two hydroelectric power stations in India.
- which among the following having high calorific value?
(hydrogen, CNG, LPG, petrol)
- LNG: METHANE
LPG:-----
- In a given cooking gas it is marked as C23 what does it mean? write the correct date?
- What is energy crisis? How can we control it?
- What are the conditions favorable for complete combustion of different fuels?
- Which is the cooking gas that we get in cylinders for domestic use? How u will know if there is leakage in domestic cylinders?
- Hydrogen is a fuel having the calorific value 15000 KJ/Kg
 - Which are the instances when hydrogen is used as fuel?
 - Why hydrogen is not used as domestic fuel?
 - What are the properties that a good fuel must have?
- Classify the given energies into brown energy and green energy.
(solar cells, atomic reaction, tidal energy, hydroelectric power, diesel engines, wind mills, thermal power)
- Write two advantages and disadvantages of solar cooker.
- What do mean by renewable and non-renewable energy sources? Give example for each.
- What are the substances obtained when coal is distilled?
- What are the four different types of coal? What is the basis of their classification?
- Biogas and biomass are two fuels. Of these two which is more advantageous? Why have you reached such a conclusion?



Prepared by

1. Subhash ASMHSS Alathur
2. Geetha Thankam V T. GHS Nagalasery
3. Mahendar MNKMHSS Chittilamchery
4. Rathi R PHS Parli
5. Sanuja GHS Tholanur
6. Kiranjith HSS Kadampazhippuram
7. Anuja E.N AVMHSS Chunangad
8. Nalini Damodaran HS Kadampazhippuram

Academic co-ordination

M.V Rachana Lecturer, DIET Palakkad