

DATE : 17/07/2022

Test Booklet Code



**S5**

**AOLBH**

Corporate Office : Aakash Tower, 8, Pusa Road, New Delhi-110005 | Ph.: 011-47623456

## Questions & Answers

Time : 3 hrs. 20 Min.

M.M. : 720

*for*

## NEET (UG)-2022

### Important Instructions :

1. The test is of **3.20 hours** duration and the Test Booklet contains **200** multiple choice questions (Four options with a single correct answer). There are two sections in each subject, i.e. Section-A & Section-B. You have to attempt all 35 questions from Section-A & only 10 questions from Section-B out of 15. (**Candidates are advised to read all 15 questions in each subject of Section-B** before they start attempting the question paper. In the event of a candidate attempting more than ten questions, **the first ten questions answered by the candidate shall be evaluated.**)
2. Each question carries **4 marks**. For each correct response, the candidate will get **4 marks**. For every wrong response **1 mark** shall be deducted from the total scores. The maximum marks are **720**.
3. Use **Blue / Black Ball point Pen only** for writing particulars on this page / marking responses on Answer Sheet.
4. Rough work is to be done in the space provided for this purpose in the Test Booklet only.
5. On completion of the test, the candidate must handover the Answer Sheet to the Invigilator before leaving the Room / Hall. The candidates are allowed to take away this Test Booklet with them.
6. The CODE for this Booklet is **S5**.
7. The candidates should ensure that the Answer Sheet is not folded. Do not make any stray marks on the Answer Sheet. Do not write your Roll No. anywhere else except in the specified space in the Test Booklet/Answer Sheet. Use of white fluid for correction is **NOT** permissible on the Answer Sheet.
8. Each candidate must show on-demand his/her Admission Card to the Invigilator.
9. No candidate, without special permission of the Centre Superintendent or Invigilator, would leave his/her seat.
10. Use of Electronic/Manual Calculator is prohibited.
11. The candidates are governed by all Rules and Regulations of the examination with regard to their conduct in the Examination Hall. All cases of unfair means will be dealt with as per Rules and Regulations of this examination.
12. No part of the Test Booklet and Answer Sheet shall be detached under any circumstances.
13. The candidates will write the Correct Test Booklet Code as given in the Test Booklet / Answer Sheet in the Attendance Sheet.

PHYSICS

SECTION-A

1. The dimensions  $[MLT^{-2}A^{-2}]$  belong to the

- (1) Magnetic permeability
- (2) Electric permittivity
- (3) Magnetic flux
- (4) Self inductance

**Answer (1)**

2. An ideal gas undergoes four different processes from the same initial state as shown in the figure below. Those processes are adiabatic, isothermal, isobaric and isochoric. The curve which represents the adiabatic process among 1, 2, 3 and 4 is

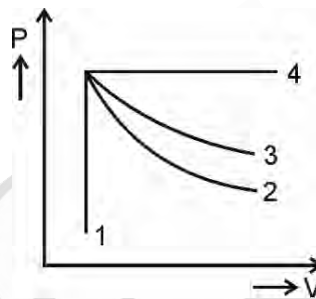

- (1) 3
- (2) 4
- (3) 1
- (4) 2

**Answer (4)**

3. A biconvex lens has radii of curvature, 20 cm each. If the refractive index of the material of the lens is 1.5, the power of the lens is

- (1) +5D
- (2) Infinity
- (3) +2D
- (4) +20D

**Answer (1)**

4. The ratio of the radius of gyration of a thin uniform disc about an axis passing through its centre and normal to its plane to the radius of gyration of the disc about its diameter is

- (1) 4 : 1
- (2)  $1 : \sqrt{2}$
- (3) 2 : 1
- (4)  $\sqrt{2} : 1$

**Answer (4)**

5. The angle between the electric lines of force and the equipotential surface is

- (1)  $90^\circ$
- (2)  $180^\circ$
- (3)  $0^\circ$
- (4)  $45^\circ$

**Answer (1)**

6. Two objects of mass 10 kg and 20 kg respectively are connected to the two ends of a rigid rod of length 10 m with negligible mass. The distance of the center of mass of the system from the 10 kg mass is

- (1) 10 m
- (2) 5 m
- (3)  $\frac{10}{3}$  m
- (4)  $\frac{20}{3}$  m

**Answer (4)**

7. The ratio of the distances travelled by a freely falling body in the 1<sup>st</sup>, 2<sup>nd</sup>, 3<sup>rd</sup> and 4<sup>th</sup> second

- (1) 1 : 3 : 5 : 7
- (2) 1 : 1 : 1 : 1
- (3) 1 : 2 : 3 : 4
- (4) 1 : 4 : 9 : 16

**Answer (1)**

8. A spherical ball is dropped in a long column of a highly viscous liquid. The curve in the graph shown, which represents the speed of the ball ( $v$ ) as a function of time ( $t$ ) is

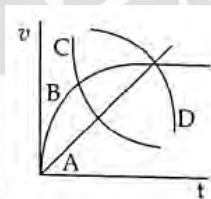

- (1) C
- (2) D
- (3) A
- (4) B

**Answer (4)**

9. The angular speed of a fly wheel moving with uniform angular acceleration changes from 1200 rpm to 3120 rpm in 16 seconds. The angular acceleration in  $\text{rad/s}^2$  is

- (1)  $12\pi$
- (2)  $104\pi$
- (3)  $2\pi$
- (4)  $4\pi$

**Answer (4)**

10. In a Young's double slit experiment, a student observes 8 fringes in a certain segment of screen when a monochromatic light of 600 nm wavelength is used. If the wavelength of light is changed to 400 nm, then the number of fringes he would observe in the same region of the screen is
- (1) 9
  - (2) 12
  - (3) 6
  - (4) 8

**Answer (2)**

11. Match List-I with List-II

	List-I (Electromagnetic waves)		List-II (Wavelength)
(a)	AM radio waves	(i)	$10^{-10}$ m
(b)	Microwaves	(ii)	$10^2$ m
(c)	Infrared radiations	(iii)	$10^{-2}$ m
(d)	X-rays	(iv)	$10^{-4}$ m

Choose the correct answer from the options given below

- (1) (a) - (iii), (b) - (iv), (c) - (ii), (d) - (i)
- (2) (a) - (ii), (b) - (iii), (c) - (iv), (d) - (i)
- (3) (a) - (iv), (b) - (iii), (c) - (ii), (d) - (i)
- (4) (a) - (iii), (b) - (ii), (c) - (i), (d) - (iv)

**Answer (2)**

12. The graph which shows the variation of the de Broglie wavelength ( $\lambda$ ) of a particle and its associated momentum ( $p$ ) is

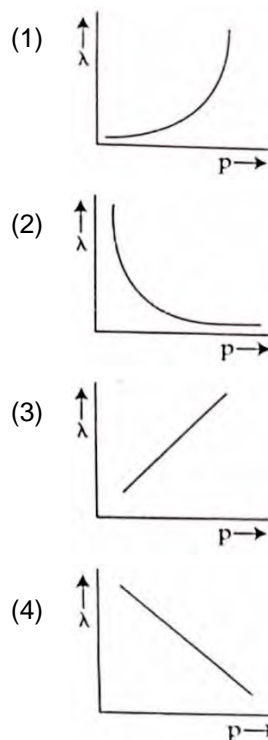

**Answer (2)**

13. When light propagates through a material medium of relative permittivity  $\epsilon_r$  and relative permeability  $\mu_r$ , the velocity of light,  $v$  is given by ( $c$ -velocity of light in vacuum)

(1)  $v = \sqrt{\frac{\epsilon_r}{\mu_r}}$

(2)  $v = \frac{c}{\sqrt{\epsilon_r \mu_r}}$

(3)  $v = c$

(4)  $v = \sqrt{\frac{\mu_r}{\epsilon_r}}$

**Answer (2)**

14. If a soap bubble expands, the pressure inside the bubble

- (1) Remains the same  
(2) Is equal to the atmospheric pressure  
(3) Decreases  
(4) Increases

**Answer (3)**

15. A body of mass 60 g experiences a gravitational force of 3.0 N, when placed at a particular point. The magnitude of the gravitational field intensity at that point is

- (1) 20 N/kg  
(2) 180 N/kg  
(3) 0.05 N/kg  
(4) 50 N/kg

**Answer (4)**

16. In the given nuclear reaction, the element  $X$  is

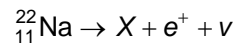

- (1)  ${}_{10}^{22}\text{Ne}$   
(2)  ${}_{12}^{22}\text{Mg}$   
(3)  ${}_{11}^{23}\text{Na}$   
(4)  ${}_{10}^{23}\text{Ne}$

**Answer (1)**

17. Let  $T_1$  and  $T_2$  be the energy of an electron in the first and second excited states of hydrogen atoms, respectively. According to the Bohr's model of an atom, the ratio  $T_1 : T_2$  is

- (1) 4 : 9  
(2) 9 : 4  
(3) 1 : 4  
(4) 4 : 1

**Answer (2)**

18. When two monochromatic lights of frequency,  $\nu$  and  $\frac{\nu}{2}$  are incident on a photoelectric metal, their stopping potential becomes  $\frac{V_s}{2}$  and  $V_s$  respectively. The threshold frequency for this metal is

- (1)  $\frac{2}{3}\nu$
- (2)  $\frac{3}{2}\nu$
- (3)  $2\nu$
- (4)  $3\nu$

**Answer (2\*)**

\* Language of question is wrongly framed. The values of stopping potentials must be interchanged.

19. A light ray falls on a glass surface of refractive index  $\sqrt{3}$ , at an angle  $60^\circ$ . The angle between the refracted and reflected rays would be

- (1)  $90^\circ$
- (2)  $120^\circ$
- (3)  $30^\circ$
- (4)  $60^\circ$

**Answer (1)**

20. A shell of mass  $m$  is at rest initially. It explodes into three fragments having mass in the ratio 2 : 2 : 1. If the fragments having equal mass fly off along mutually perpendicular directions with speed  $v$ , the speed of the third (lighter) fragment is

- (1)  $2\sqrt{2}v$
- (2)  $3\sqrt{2}v$
- (3)  $v$
- (4)  $\sqrt{2}v$

**Answer (1)**

21. Two hollow conducting spheres of radii  $R_1$  and  $R_2$  ( $R_1 \gg R_2$ ) have equal charges. The potential would be

- (1) Equal on both the spheres
- (2) Dependent on the material property of the sphere
- (3) More on bigger sphere
- (4) More on smaller sphere

**Answer (4)**

22. As the temperature increases, the electrical resistance

- (1) Increases for conductors but decreases for semiconductors
- (2) Decreases for conductors but increases for semiconductors
- (3) Increases for both conductors and semiconductors
- (4) Decreases for both conductors and semiconductors

**Answer (1)**

23. The displacement-time graphs of two moving particles make angles of  $30^\circ$  and  $45^\circ$  with the x-axis as shown in the figure. The ratio of their respective velocity is

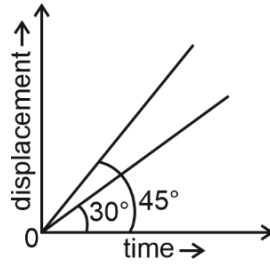

- (1) 1 : 2
- (2)  $1 : \sqrt{3}$
- (3)  $\sqrt{3} : 1$
- (4) 1 : 1

**Answer (2)**

24. A square loop of side 1 m and resistance  $1 \Omega$  is placed in a magnetic field of 0.5 T. If the plane of loop is perpendicular to the direction of magnetic field, the magnetic flux through the loop is

- (1) 1 weber
- (2) Zero weber
- (3) 2 weber
- (4) 0.5 weber

**Answer (4)**

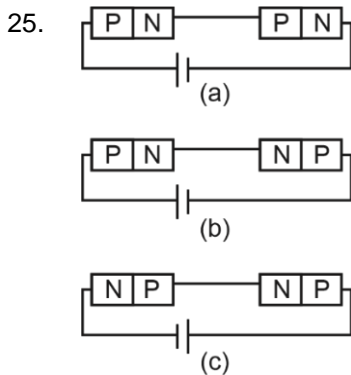

In the given circuits (a), (b) and (c), the potential drop across the two *p-n* junctions are equal in

- (1) Circuit (c) only
- (2) Both circuits (a) and (c)
- (3) Circuit (a) only
- (4) Circuit (b) only

**Answer (2)**

26. A copper wire of length 10 m and radius  $\left(\frac{10^{-2}}{\sqrt{\pi}}\right)$  m has electrical resistance of  $10 \Omega$ . The current density in the wire for an electric field strength of 10 (V/m) is
- (1)  $10^{-5} \text{ A/m}^2$
  - (2)  $10^5 \text{ A/m}^2$
  - (3)  $10^4 \text{ A/m}^2$
  - (4)  $10^6 \text{ A/m}^2$

**Answer (2)**

27. An electric lift with a maximum load of 2000 kg (lift + passengers) is moving up with a constant speed of  $1.5 \text{ ms}^{-1}$ . The frictional force opposing the motion is 3000 N. The minimum power delivered by the motor to the lift in watts is : ( $g = 10 \text{ ms}^{-2}$ )
- (1) 34500
  - (2) 23500
  - (3) 23000
  - (4) 20000

**Answer (1)**

28. Given below are two statements

**Statement I** : Biot-Savart's law gives us the expression for the magnetic field strength of an infinitesimal current element ( $Idl$ ) of a current carrying conductor only.

**Statement II** : Biot-Savart's law is analogous to Coulomb's inverse square law of charge  $q$ , with the former being related to the field produce by a scalar source,  $Idl$  while the latter being produced by a vector source,  $q$ .

In light of above statements choose the most appropriate answer from the options given below

- (1) Statement I is correct and Statement II is incorrect
- (2) Statement I is incorrect and Statement II is correct
- (3) Both Statement I and Statement II are correct
- (4) Both Statement I and Statement II are incorrect

**Answer (1)**

29. Two resistors of resistance,  $100 \Omega$  and  $200 \Omega$  are connected in parallel in an electrical circuit. The ratio of the thermal energy developed in  $100 \Omega$  to that in  $200 \Omega$  in a given time is
- (1) 1 : 4
  - (2) 4 : 1
  - (3) 1 : 2
  - (4) 2 : 1

**Answer (4)**

30. The energy that will be ideally radiated by a 100 kW transmitter in 1 hour is
- (1)  $36 \times 10^5 \text{ J}$
  - (2)  $1 \times 10^5 \text{ J}$
  - (3)  $36 \times 10^7 \text{ J}$
  - (4)  $36 \times 10^4 \text{ J}$

**Answer (3)**



31. A long solenoid of radius 1 mm has 100 turns per mm. If 1 A current flows in the solenoid, the magnetic field strength at the centre of the solenoid is
- (1)  $12.56 \times 10^{-4}$  T
  - (2)  $6.28 \times 10^{-4}$  T
  - (3)  $6.28 \times 10^{-2}$  T
  - (4)  $12.56 \times 10^{-2}$  T

**Answer (4)**

32. Plane angle and solid angle have
- (1) No units and no dimensions
  - (2) Both units and dimensions
  - (3) Units but no dimensions
  - (4) Dimensions but no units

**Answer (3)**

33. In half wave rectification, if the input frequency is 60 Hz, then the output frequency would be
- (1) 60 Hz
  - (2) 120 Hz
  - (3) Zero
  - (4) 30 Hz

**Answer (1)**

34. The peak voltage of the ac source is equal to
- (1)  $\sqrt{2}$  times the rms value of the ac source
  - (2)  $1/\sqrt{2}$  times the rms value of the ac source
  - (3) The value of voltage supplied to the circuit
  - (4) The rms value of the ac source

**Answer (1)**

35. If the initial tension on a stretched string is doubled, then the ratio of the initial and final speeds of a transverse wave along the string is
- (1)  $1:\sqrt{2}$
  - (2) 1 : 2
  - (3) 1 : 1
  - (4)  $\sqrt{2}:1$

**Answer (1)**

SECTION-B

36. Two pendulums of length 121 cm and 100 cm start vibrating in phase. At some instant, the two are at their mean position in the same phase. The minimum number of vibrations of the shorter pendulum after which the two are again in phase at the mean position is:

- (1) 10
- (2) 8
- (3) 11
- (4) 9

**Answer (3)**

37. A ball is projected with a velocity,  $10 \text{ ms}^{-1}$ , at an angle of  $60^\circ$  with the vertical direction. Its speed at the highest point of its trajectory will be

- (1)  $5 \text{ ms}^{-1}$
- (2)  $10 \text{ ms}^{-1}$
- (3) Zero
- (4)  $5\sqrt{3} \text{ ms}^{-1}$

**Answer (4)**

38. A wheatstone bridge is used to determine the value of unknown resistance  $X$  by adjusting the variable resistance  $Y$  as shown in the figure. For the most precise measurement of  $X$ , the resistances  $P$  and  $Q$

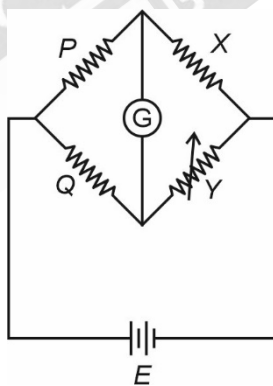

- (1) should be very large and unequal
- (2) do not play any significant role
- (3) should be approximately equal to  $2X$
- (4) should be approximately equal and are small

**Answer (4)**

39. Two point charges  $-q$  and  $+q$  are placed at a distance of  $L$ , as shown in the figure.

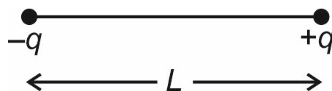

The magnitude of electric field intensity at a distance  $R$  ( $R \gg L$ ) varies as:

- (1)  $\frac{1}{R^4}$
- (2)  $\frac{1}{R^6}$
- (3)  $\frac{1}{R^2}$
- (4)  $\frac{1}{R^3}$

**Answer (4)**

40. Given below are two statements : One is labelled as **Assertion (A)** and the other is labelled as **Reason (R)**.

**Assertion (A):** The stretching of a spring is determined by the shear modulus of the material of the spring.

**Reason (R):** A coil spring of copper has more tensile strength than a steel spring of same dimensions.

In the light of the above statements, choose the **most appropriate** answer from the options given below

- (1) **(A)** is true but **(R)** is false
- (2) **(A)** is false but **(R)** is true
- (3) Both **(A)** and **(R)** are true and **(R)** is the correct explanation of **(A)**
- (4) Both **(A)** and **(R)** are true and **(R)** is not the correct explanation of **(A)**

**Answer (1)**

41. A nucleus of mass number 189 splits into two nuclei having mass number 125 and 64. The ratio of radius of two daughter nuclei respectively is

- (1) 5 : 4
- (2) 25 : 16
- (3) 1 : 1
- (4) 4 : 5

**Answer (1)**

42. Match List-I with List-II

	List-I		List-II
(a)	Gravitational constant (G)	(i)	$[L^2T^{-2}]$
(b)	Gravitational potential energy	(ii)	$[M^{-1}L^3T^{-2}]$
(c)	Gravitational potential	(iii)	$[LT^{-1}]$
(d)	Gravitational intensity	(iv)	$[ML^2T^{-2}]$

Choose the correct answer from the options given below

- (1) (a) - (ii), (b) - (iv), (c) - (iii), (d) - (i)
- (2) (a) - (iv), (b) - (ii), (c) - (i), (d) - (iii)
- (3) (a) - (ii), (b) - (i), (c) - (iv), (d) - (iii)
- (4) (a) - (ii), (b) - (iv), (c) - (i), (d) - (iii)

**Answer (4)**

 43. The area of a rectangular field (in  $m^2$ ) of length 55.3 m and breadth 25 m after rounding off the value for correct significant digits is

- (1) 1382.5
- (2)  $14 \times 10^2$
- (3)  $138 \times 10^1$
- (4) 1382

**Answer (2)**

 44. A big circular coil of 1000 turns and average radius 10 m is rotating about its horizontal diameter at  $2 \text{ rad s}^{-1}$ . If the vertical component of earth's magnetic field at that place is  $2 \times 10^{-5} \text{ T}$  and electrical resistance of the coil is  $12.56 \Omega$ , then the maximum induced current in the coil will be

- (1) 1 A
- (2) 2 A
- (3) 0.25 A
- (4) 1.5 A

**Answer (1)**

 45. Two transparent media *A* and *B* are separated by a plane boundary. The speed of light in those media are  $1.5 \times 10^8 \text{ m/s}$  and  $2.0 \times 10^8 \text{ m/s}$ , respectively. The critical angle for a ray of light for these two media is

- (1)  $\tan^{-1}(0.500)$
- (2)  $\tan^{-1}(0.750)$
- (3)  $\sin^{-1}(0.500)$
- (4)  $\sin^{-1}(0.750)$

**Answer (4)**

46. A series LCR circuit with inductance  $10\text{ H}$ , capacitance  $10\ \mu\text{F}$ , resistance  $50\ \Omega$  is connected to an ac source of voltage,  $V = 200\sin(100t)$  volt. If the resonant frequency of the LCR circuit is  $\nu_0$  and the frequency of the ac source is  $\nu$ , then

- (1)  $\nu_0 = \frac{50}{\pi}\text{ Hz}$ ,  $\nu = 50\text{ Hz}$
- (2)  $\nu = 100\text{ Hz}$ ;  $\nu_0 = \frac{100}{\pi}\text{ Hz}$
- (3)  $\nu_0 = \nu = 50\text{ Hz}$
- (4)  $\nu_0 = \nu = \frac{50}{\pi}\text{ Hz}$

**Answer (4)**

47. A capacitor of capacitance  $C = 900\ \text{pF}$  is charged fully by  $100\text{ V}$  battery  $B$  as shown in figure (a). Then it is disconnected from the battery and connected to another uncharged capacitor of capacitance  $C = 900\ \text{pF}$  as shown in figure (b). The electrostatic energy stored by the system (b) is

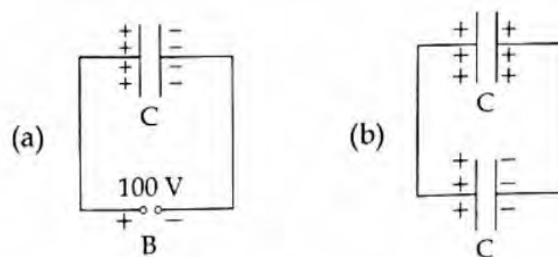

- (1)  $2.25 \times 10^{-6}\text{ J}$
- (2)  $1.5 \times 10^{-6}\text{ J}$
- (3)  $4.5 \times 10^{-6}\text{ J}$
- (4)  $3.25 \times 10^{-6}\text{ J}$

**Answer (1)**

48. From Ampere's circuital law for a long straight wire of circular cross-section carrying a steady current, the variation of magnetic field in the inside and outside region of the wire is
- (1) A linearly increasing function of distance  $r$  upto the boundary of the wire and then decreasing one with  $\frac{1}{r}$  dependence for the outside region.
  - (2) A linearly decreasing function of distance upto the boundary of the wire and then a linearly increasing one for the outside region.
  - (3) Uniform the remains constant for both the regions.
  - (4) A linearly increasing function of distance upto the boundary of the wire and then linearly decreasing for the outside region.

**Answer (1)**

49.

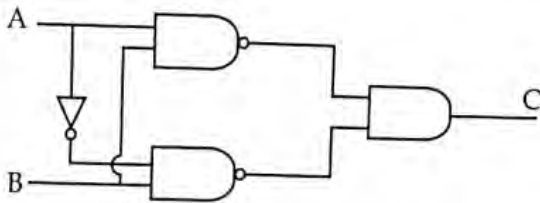

The truth table for the given logic circuit is

(1)

A	B	C
0	0	1
0	1	0
1	0	1
1	1	0

(2)

A	B	C
0	0	0
0	1	1
1	0	0
1	1	1

(3)

A	B	C
0	0	0
0	1	1
1	0	1
1	1	0

(4)

A	B	C
0	0	1
0	1	0
1	0	0
1	1	1

**Answer (1)**

50. The volume occupied by the molecules contained in 4.5 kg water at STP, if the intermolecular forces vanish away is

- (1)  $5.6 \times 10^{-3} \text{ m}^3$
- (2)  $5.6 \text{ m}^3$
- (3)  $5.6 \times 10^6 \text{ m}^3$
- (4)  $5.6 \times 10^3 \text{ m}^3$

**Answer (2)**