

**SAMPLE QUESTION PAPER
PHYSICAL EDUCATION (048)
SESSION (2022-23)**

TIME ALLOWED: 3 HRS

MAX. MARKS: 70

GENERAL INSTRUCTIONS:

- 1) The question paper consists of 5 sections and 37 Questions.
- 2) Section A consists of question 1-18 carrying 1 mark each and is multiple choice questions. All questions are compulsory.
- 3) Sections B consist of questions 19-24 carrying 2 marks each and are very short answer types and should not exceed 60-90 words. Attempt any 5.
- 4) Sections C consist of Question 25-30 carrying 3 marks each and are short answer types and should not exceed 100-150 words. Attempt any 5.
- 5) Sections D consist of Question 31-33 carrying 4 marks each and are case studies. There is internal choice available.
- 6) Section E consists of Question 34-37 carrying 5 marks each and are short answer types and should not exceed 200-300 words. Attempt any 3.

(SECTION -A)

Q1. Identify the asana:



- a) Paschimottanasana
- b) Halasana
- c) Vajrasana
- d) Dhanurasana

(Question for visually impaired)

Which asana amongst these can be done just after having meals?

- a) Bhujangasana
- b) Dhanurasana
- c) Vajrasana
- d) Ardhamatsyendrasana

Q2. A person who likes to learn new things, new concepts and new experiences are categorized as _____.

- a) Agreeableness
- b) Extroversion
- c) Conscientiousness
- d) Openness

Q3. Cartwheel in gymnastics is an example of _____

- a) Static Equilibrium
- b) Dynamic Equilibrium
- c) Active Equilibrium
- d) Passive Equilibrium

Q4. Slow twitch fibres are _____ in colour.

- a) White
- b) Red
- c) Transparent
- d) Brown

Q5. Jumping on the spot is an example of _____

- a) Iso-metric
- b) Iso-tonic
- c) Iso-kinetic
- d) Iso-kinesthetic

Q6. Take-off in Long jump is an example of _____ strength.

- a) Explosive strength
- b) Maximum strength
- c) Strength endurance
- d) Static strength

Q7.. The amount of oxygen which can be absorbed and consumed by the working muscles from the blood is called _____

- a) Oxygen Uptake
- b) Oxygen Intake
- c) Oxygen Transport
- d) Vital capacity

Q8. In Law of Acceleration, acceleration of an object is inversely proportionate to its

-
- a) Force
 - b) Mass
 - c) Speed
 - d) Size

*Q9. Given below are the two statements labeled Assertion (A) and Reason (R).

Assertion: Intrinsic motivation has long term benefits.

Reason: As factors behind it are naturally pursuing actions that provide fun, pleasure, fulfillment or challenge

In the context of the above two statements, which one of the following is correct?

- a) Both (A) and (R) are true and (R) is the correct explanation of (A).
- b) Both (A) and (R) are true, but (R) is not the correct explanation of (A).
- c) (A) is true, but (R) is false.
- d) (A) is false, but (R) is true

Q10. Carbohydrates which are soluble in water and crystalline in structure.

- a) Simple
- b) Complex
- c) Compound
- d) Complicated

Q11. Which amongst these is not a micro mineral?

- a) Iodine
- b) Magnesium
- c) Iron
- d) Copper

Q12. Which asana is helpful in increasing height?

- a) Sukhasana
- b) Tadasana
- c) Bhujangasana
- d) Vajrasana

*Q13. How many byes will be given if there are 17 teams?

- a) 1
- b) 8
- c) 15
- d) 12

* Q14. How many matches will be played in the knockout tournaments first round if there are 15 teams?

- a) 8
- b) 7
- c) 5
- d) 6

Q15. Watching others play and enjoy which in turn motivates the Child with special need to participate is a part of which kind of strategy?

- a) Mental
- b) Physical
- c) Psychological
- d) Social

*Q16. Match the following:

- | | |
|------------------|------------------|
| I. Garudasana. | 1.Round shoulder |
| II. Gomukhasana. | 2. Lordosis |
| III. Chakrasana. | 3. Bow legs |
| IV. Naukasana. | 4. Knock knees |

- a) I-3,II-4,III-1,IV-2
- b) I-1,II-3,III-4,IV-2
- c) I-4,II-2,III-1,IV-3
- d) I-2,II-3,III-4,IV-1

*Q17. Match the following:

- | | |
|---------------------------|---------------------------|
| I. Chair stand test. | 1. Lower Body strength |
| II. Arm curl test. | 2. Aerobic Endurance |
| III. Back scratch test. | 3. Upper body strength |
| IV. Six minute walk test. | 4. Upper body flexibility |

- a) I-1,II-3,III-4,IV-2
- b) I-2,II-3,III-1,IV-4
- c) I-1,II-3,III-2,IV-4
- d) I-2,II-3,III-4,IV-1

Q18. Weakening of bones due to loss of bone density and improper bone formation is known as _____

- a) Amenorrhea
- b) Anorexia Nervosa
- c) Osteoporosis
- d) Lordosis

(SECTION B)

- Q19. List down any four effects of exercise on the muscular system. (0.5*4)
- Q20. List down any four benefits of self talk by athletes in sports (0.5*4)
- Q21. List down any four advantages of fartlek training method. (0.5*4)
- Q22. Explain any two types of soft tissue injuries with help of examples. (0.5*4)
- Q23. Write down the objectives and administration of the flamingo test. (1+1)
- *Q24. What should be the basic nutrient in a weightlifter's diet and why? (1+1)

(SECTION C)

- *Q25. Create a mind map including any six advantages of physical activities for children with special needs. (0.5X6=3)
- Q26. What are carbohydrates? Differentiate between its types. {1+ (0.5*4)}
- Q27. Define bye. Explain the rules of giving bye with help of an example. (1+2)
- *Q28. Make a table explaining any three personalities from Big five theory and their characteristics. (1+1+1)
- Q29.. Explain any three physiological factors determining strength. (1+1+1)
- Q30. What is the meaning of female athletes Triad? Explain any two in brief. (1+ 2)

(SECTION D)

*31.

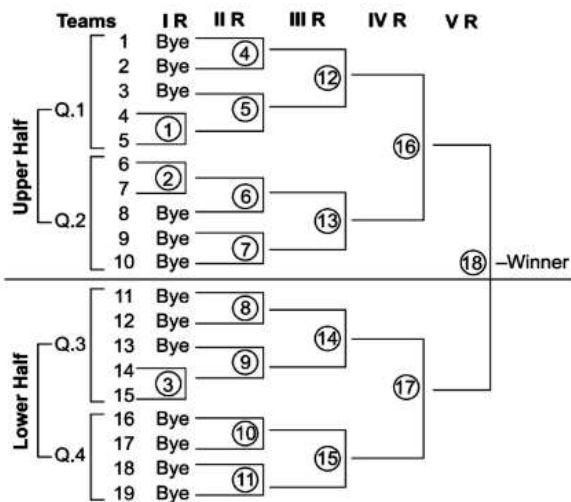

On the basis of above given fixture answer the following questions: (4X1=4)

- total number of matches in 2nd round are _____
- What is the formula for calculating the total number of matches?
- The fourth round in this case can also be called as _____
- What is the formula for calculating the number of byes

OR

The formula for calculating number of rounds is _____

(Question for visually impaired)

List down any four committees working during conduct of a competition and briefly explain their role.

Q32. The teachers as well as coaches always make their best efforts to improve the performance of their students in various competitive games and sports. They can help to improve the performance of students if they have adequate knowledge of biomechanics.

(4X1=4)



- The more force one exerts on the downward bounce, the higher the ball bounces into the air. Which law is this statement being referred to?
- Among the above given pictures, Newton's 3rd law is depicted in _____
- Newton's second law is also known as _____
- The study of human body and various forces acting on it is _____

OR

A high jumper can jump higher off a solid surface because it opposes his or her body with as much force as he or she is able to generate. This example refers to which law of motion?

(Question for visually impaired)

What is equilibrium? Explain its types along with the factors increasing equilibrium. (1+4)

Q33. In relation to the pictures, answer the following questions.



- What is the mission of the first organization?
- What is the Motto of the first organization?
- Until 1965 the games in the second picture were known as _____
- Second picture games are conducted after every _____ years.

(Question for visually impaired)

Write a brief note on Paralympics including its origin, describing the various categories and criteria..

(SECTION E)

Q34. List down any four asanas used for prevention of asthma. Explain the procedure for administration of any one of them with help of a stick diagram. (2+2+1)

*Q35. Make a table of test items listed under fitness test by SAI (Age group 9-18 yrs) along with the objectives of conducting them. Explain the administration of any one of them. (4+1)

Q36. Define flexibility along with its types. Explain any two methods used to develop flexibility. (2+3)

Q37. Define Projectile and explain any two factors affecting projectile with help of examples from sports. (1+4)