

Class X 2022-23

Science (086)

Time: 3 Hours

Max. Marks: 80

General Instructions:

1. This question paper consists of 39 questions in 5 sections.
 2. All questions are compulsory. However, an internal choice is provided in some questions. A student is expected to attempt only one of these questions.
 3. Section A consists of 20 Objective Type questions carrying 1 mark each.
 4. Section B consists of 6 Very Short questions carrying 02 marks each. Answers to these questions should be in the range of 30 to 50 words.
 5. Section C consists of 7 Short Answer type questions carrying 03 marks each. Answers to these questions should be in the range of 50 to 80 words.
 6. Section D consists of 3 Long Answer type questions carrying 05 marks each. Answer to these questions should be in the range of 80 to 120 words.
 7. Section E consists of 3 source-based/case-based units of assessment of 04 marks each with sub-parts.
-

SECTION-A

Select and write one most appropriate option out of the four options given for each of the questions 1 – 20.

1. Arrange the following in the increasing order of pH values according to given pH scale.



- A. NaOH solution
B. Blood
C. Lemon juice
D. Milk of magnesia
- (a) $C < B < D < A$
(b) $A < B < C < D$
(c) $D < C < B < A$
(d) $A < B < D < C$
2. Identify the substances that is oxidized and the substances that is reduced in the following reactions:
$$\text{CuO (s)} + \text{H}_2\text{(g)} \longrightarrow \text{Cu (s)} + \text{H}_2\text{O (l)}$$
- (a) H_2, CuO
(b) $\text{H}_2, \text{H}_2\text{O}$
(c) H_2, Cu
(d) Cu, H_2

Continue on next page.....

3.

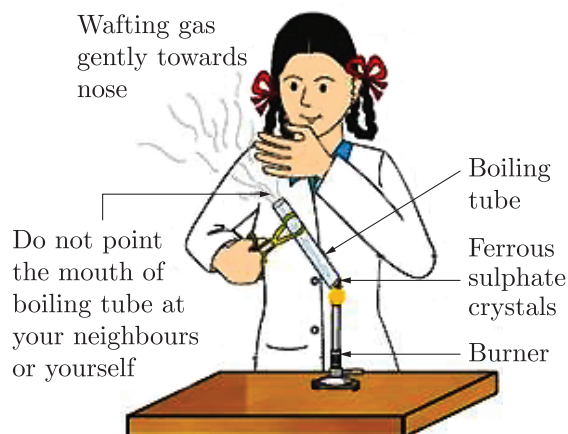

The colour of the crystals before heating and after heating are respectively:

- (a) Pale green, Reddish brown
- (b) Reddish brown, Pale green
- (c) Reddish brown, Reddish brown
- (d) Pale green, Pale green

4. Which of the following are correctly matched in the given table?

1.	Dissolution	Solute gets dissolved in a solvent.
2.	Exothermic	Heat is absorbed.
3.	Reversible change	Reactants can be obtained.

- (a) 1 and 2
- (b) 2 and 3
- (c) 1 and 3
- (d) 1, 2 and 3

5. An element reacts with oxygen to give a compound with a high melting point. This compound is also soluble in water. The element is likely to be

- (a) calcium
- (b) carbon
- (c) silicon
- (d) iron

Continue on next page.....

6. A metal is treated with dilute sulphuric acid. The gas evolved is collected by the method shown in the figure.

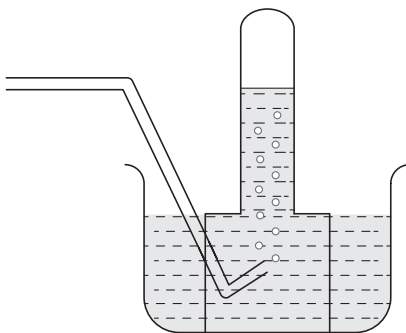

The name of the gas is

- (a) Hydrogen
 (b) Oxygen
 (c) Nitrogen
 (d) Helium
7. Which of the following is the structural formula of ethyne ?

- (a) $\text{H} - \text{C} \equiv \text{C} - \text{H}$
 (b) $\text{H}_3 - \text{C} \equiv \text{C} - \text{H}$

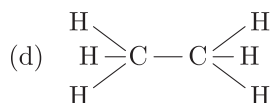
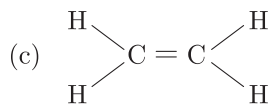

8. An experiment is set up as shown. Flasks 1 and 2 contain lime water. Air is pumped through the flasks.

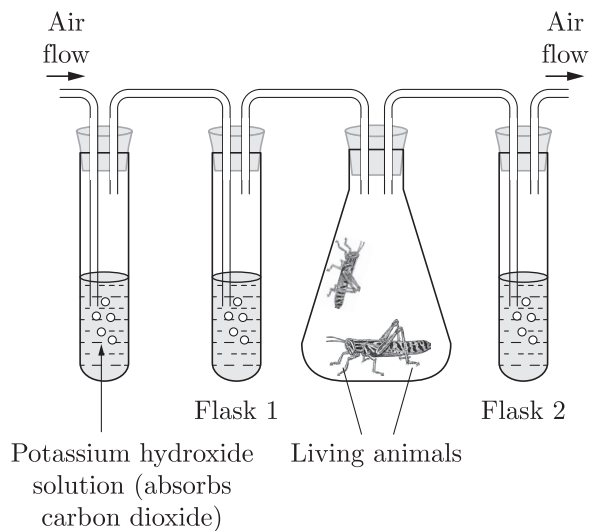

Continue on next page.....

What is the appearance of lime water in flasks 1 and 2 after a period of ten minutes?

	Flask 1	Flask 2
(a)	Clear	Clear
(b)	Clear	White/Cloudy
(c)	White/Cloudy	Clear
(d)	White/Cloudy	White/Cloudy

9. From the mouth the food is taken to the stomach through
- (a) Bile duct
 - (b) Pancreas
 - (c) Diaphragm
 - (d) Oesophagus
10. Two pink coloured flowers on crossing resulted in 1 red, 2 pink and 1 white flower progeny. The nature of the cross will be
- (a) double fertilisation
 - (b) self pollination
 - (c) cross fertilisation
 - (d) no fertilisation
11. Which statement is not true about thyroxin ?
- (a) Iron is essential for the synthesis of thyroxin
 - (b) It regulates carbohydrates, protein and fat metabolism in the body
 - (c) Thyroid gland requires iodine to synthesise thyroxin
 - (d) Thyroxin is also called thyroid hormone.
12. During adolescence, several changes occur in the human body. Mark one change associated with maturation in boys
- (a) loss of milk teeth
 - (b) increase in height
 - (c) cracking of voice
 - (d) weight gain

Continue on next page.....

13.

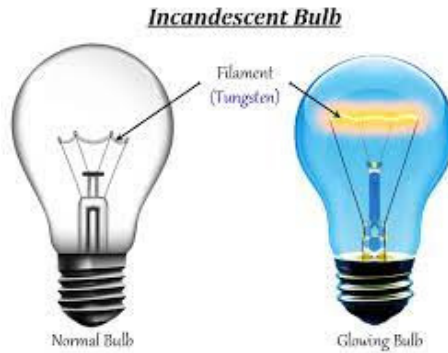

A current of 1 A is drawn by a filament of an electric bulb shown in the figure. Number of electrons passing through a cross section of the filament in 16 seconds would be roughly

- (a) 10^{20} (b) 10^{16}
(c) 10^{18} (d) 10^{23}

14. A circular loop placed in a plane perpendicular to the plane of paper carries a current when the key is ON. The current as seen from points *A* and *B* (in the plane of paper and on the axis of the coil) is anti-clockwise and clockwise respectively. The magnetic field lines point from *B* to *A*. The *N*-pole of the resultant magnet is on the face close to

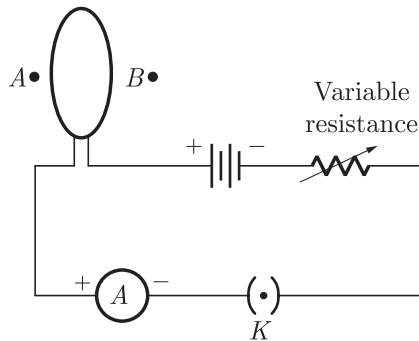

- (a) *A*
(b) *B*
(c) *A* if the current is small, and *B* if the current is large
(d) *B* if the current is small and *A* if the current is large.

15. Identify the circuit (Figure) in which the electrical components have been properly connected.

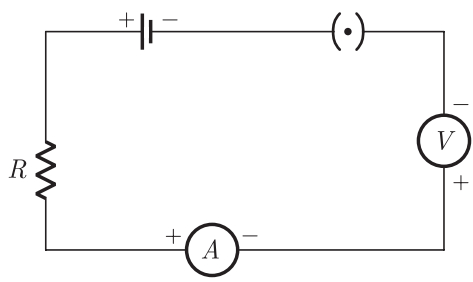

(i)

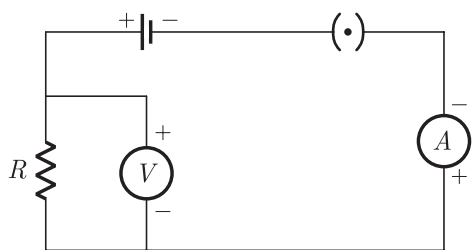

(ii)

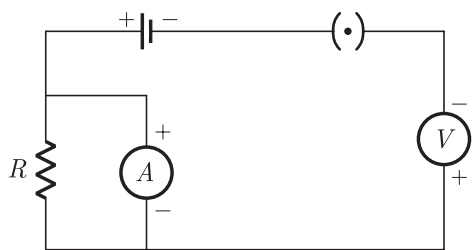

(iii)

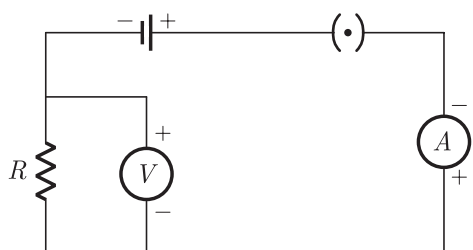

(iv)

- (a) (i)
- (c) (iii)

- (b) (ii)
- (d) (iv)

16. Which of the following correctly describes the magnetic field near long straight wire ?
- (a) the field consists of straight lines perpendicular to the wire.
 - (b) the field consists of straight lines parallel to the wire.
 - (c) the field consists of radial lines originating from the wire.
 - (d) the field consists of concentric circles centered on the wire.

Question no. 17 to 20 are Assertion-Reasoning based questions.

17. **Assertion :** Equation $C(s) + O_2(g) \longrightarrow CO_2(g)$ is an example of combination reaction.
Reason : In the given above equation, carbon and oxygen react to give carbon dioxide.
- (a) Both Assertion and Reason are True and Reason is the correct explanation of the Assertion.
 - (b) Both Assertion and Reason are True but Reason is not the Correct explanation of the Assertion.
 - (c) Assertion is True but the Reason is False.
 - (d) Both Assertion and Reason are False.
18. **Assertion :** Changes in non-reproductive tissues can be passed on the DNA of the germ cells.
Reason : Inherited traits include the traits developed during the lifetime of an individual that cannot be passed on to its progeny.
- (a) Both assertion (A) and reason (R) are true and reason (R) is the correct explanation of assertion (A).
 - (b) Both assertion (A) and reason (R) are true but reason (R) is not the correct explanation of assertion (A).
 - (c) Assertion (A) is true but reason (R) is false.
 - (d) Assertion (A) is false but reason (R) is true.
19. **Assertion :** The thickest muscles are present in left atrium.
Reason : Left atrium receives deoxygenated blood from the lungs.
- (a) Both Assertion and Reason are true and Reason is the correct explanation of Assertion.
 - (b) Both Assertion and Reason are true but Reason is not the correct explanation of Assertion.
 - (c) Assertion is true but Reason is false.
 - (d) Both Assertion and Reason are false.
20. **Assertion :** A direction current flows through a metallic rod, produced magnetic field only outside the rod.
Reason : There is no flow of charge carriers inside the rod.
- (a) Both assertion (A) and reason (R) are true and reason (R) is the correct explanation of assertion (A).
 - (b) Both assertion (A) and reason (R) are true but reason (R) is not the correct explanation of assertion (A).
 - (c) Assertion (A) is true but reason (R) is false.
 - (d) Assertion (A) is false but reason (R) is true.

SECTION-B

Question no. 21 to 26 are very short answer questions.

21. Define the term 'electrical conductivity' of metals. Arrange the following metals in order of their decreasing electrical conductivity :

Continue on next page.....

or

Give reasons for the following :

- (a) We can store copper sulphate solution in silver vessel but not silver nitrate solution in a copper vessel.
- (b) Food cans are coated with tin rather than zinc.

- 22. Lack of oxygen in muscles often leads to cramps among cricketers. Explain why?
- 23. During one cycle how many times blood goes to heart of fish and why ?
- 24. What are the functions of bicuspid and tricuspid valves in human heart ?
- 25. Mention the factor on which scattering of light depends. Why does the sky appear dark in space ?

or

No rainbow could be observed from the surface of the moon by the astronauts. Give reason.

- 26. Aquarium need to be cleaned once in a while whereas ponds or lakes do not require any cleaning: Explain

SECTION-C

Question no. 27 to 33 are short answer questions.

- 27. Justify with the help of an example that displacement reaction is also a redox reaction.
- 28. Give reasons for the following :
 - (a) Ionic compounds in general have high melting and boiling points.
 - (b) Highly reactive metals cannot be obtained from their oxides by heating them with carbon.
 - (c) Copper containers get a green coat when left exposed to air in the rainy season.
- 29. State the functions of the following in the alimentary canal :
 - (i) Liver
 - (ii) Gall bladder
 - (iii) Villi.

or

- (a) In the process of respiration, state the function of alveoli.
- (b) Rate of breathing in aquatic, organisms is much faster than that in terrestrial organisms. Give reasons.
- (c) Complete the following pathway showing the breakdown of glucose :

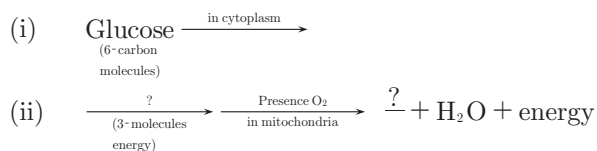

- 30. Name the type of mirror used in the following situations and support your answer with a reason :
 - (i) Mirror used for shaving.
 - (ii) Mirror used by ENT doctors.
 - (iii) Mirror used in the vehicles for viewing the traffic approaching from behind.

Continue on next page.....

31. (a) A divergent lens has focal length of 20 cm. At what distance should the object from the lens be placed so that an image is formed 10 cm away from the lens ? What is the magnification produced, by the lens ?
 (b) Draw a ray diagram to show the position and nature or the image formed by a convex lens when an object is placed between optical centre and focus of the lens.
32. (i) What is the function of earth wire in electrical instruments?
 (ii) Explain what is short circuiting an electric supply.
 (iii) What is the usual current rating of the fuse wire in the line to feed
 (a) Lights and fans?
 (b) Appliances of 2kW or more power?
- or**
- (a) Which effect of the electric current is utilised in the working of an electrical fuse ?
 (b) Is a fuse connected in series or in parallel in household circuit ?
 (c) Draw a schematic labelled diagram of a domestic circuit which has a provision of a main fuse, meter, one light bulb and a switch/socket.
33. Differentiate autotrophs hetrotrophs and decomposer and give one example of each.

SECTION-D

Question no. 34 to 36 are Long answer questions.

34. Complete the following reactions :

- (i) $\text{CH}_3\text{CH}_2\text{OH} \xrightarrow[\text{Heat}]{\text{Conc. H}_2\text{SO}_4}$
 (ii) $\text{CH}_3\text{COOH} + \text{NaHCO}_3 \longrightarrow$
 (iii) $\text{CH}_4 + \text{Cl}_2 \xrightarrow{\text{Sunlight}}$
 (iv) $\text{CH}_2 = \text{CH}_2 + \text{H}_2 \xrightarrow{\text{Ni}}$
 (v) $\text{C}_2\text{H}_5\text{OH} + \text{O}_2 \xrightarrow{\text{Alkaline KMnO}_4}$

or

- (a) What is a catalyst ? Write the chemical equation to represent the hydrogenation of ethene.
 (b) Which of the following compounds belong to the same homologous series ?
 C_2H_6 , $\text{C}_2\text{H}_6\text{O}_2$, $\text{C}_2\text{H}_6\text{O}$, C_4H_{10}
35. (a) Draw a diagram to show spore formation in Rhizopus.
 (b) With the help of an example differentiate between the process of Budding and Fragmentation.
 (c) Why is vegetative propagation practiced for growing some type of plants?
- or**
- (a) Draw a neat labelled diagram of pistil showing germination of pollen on stigma.
 (b) Give the functions of :
 (i) Stigma
 (ii) Ovary
 (c) State in brief the formation of seed in a flower.

Continue on next page.....

36. Inside the house, connections to all the devices are made in parallel, each having independent switch and fuse (if necessary). Thus, whenever some fault occurs in circuit of one particular device in one room, devices in other rooms do not suffer.

Figure shows a 240V AC mains circuit to which a number of appliances are connected and switched on.

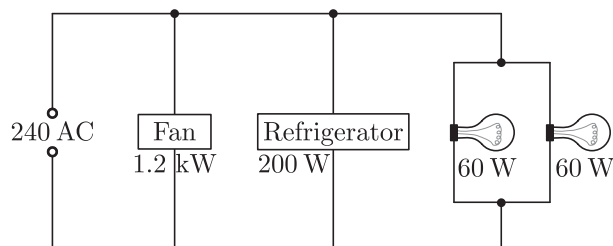

- (i) Calculate the power supplied to the circuit.
- (ii) Find out the value of electric current in the refrigerators.
- (iii) Calculate energy used by the fan in 2 hours.
- (iv) Calculate resistance of the filament of one lamp.

SECTION-E

Question no. 37 to 39 are case-based/data -based questions with 2 to 3 short sub-parts. Internal choice is provided in one of these sub-parts.

37. Some reaction of metal with some compounds are given in the table:

Metal	Iron (II) Sulphate	Copper (II) Sulphate	Zinc Sulphate	Silver Nitrate
A	No reaction	Displacement	---	---
B	Displacement	---	No reaction	---
C	No reaction	No reaction	No reaction	Displacement
D	No reaction	No reaction	No reaction	No reaction

- (i) Name the most and least active metal.
- (ii) Arrange the metals A, B, C and D in order of increasing reactivity.

or

- (ii) Container of which metal can be used to store both zinc sulphate solution and silver nitrate solution?

38. To carry out a simple function such as eating food there has to be coordination of the eyes, hands and the mouth. The eyes have to focus on the food, the hands have to pick it up and take it to the mouth where it will be chewed. All these actions have to be coordinated in such a manner that they follow a particular sequence and the action is completed. A similar mechanism is also needed for internal functions of the body. This function is carried out by the nervous system.

It is composed of :

- (a) specialised cells which can detect, receive and transmit different kinds of stimuli. These are called neurons.
- (b) nerve fibres which are certain bundles of extended processes of nerve cells.

Continue on next page.....

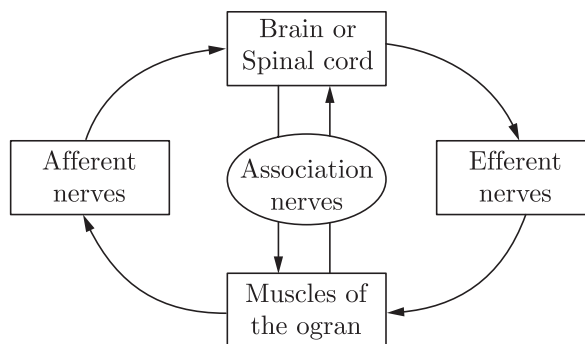

The individuals also have to adjust to the changing conditions of the body should vary their responses. At the same time, the internal conditions of the body should be maintained constant. This is called homeostasis. The internal conditions of the body are maintained at a constant by controlling the physiology of the organisms.

- (i) What will the correct sequence in which conduction of information through nerves take place?
- (ii) How homeostasis is said to maintain the equilibrium of the body?
- (iii) What function does the central nervous system perform?

or

- (iv) What happens when the dendrite tip of a nerve cell receives a signal?

39. “Change in path of a light ray as it passes from one medium to another medium is called refraction of light.”

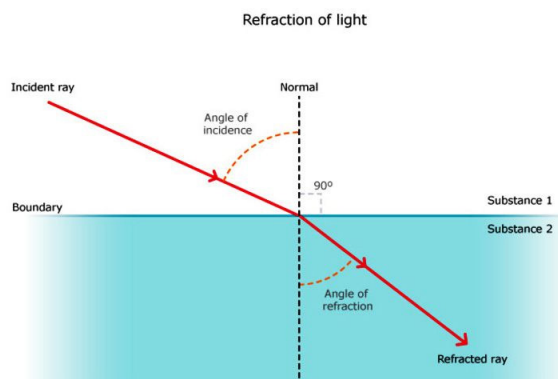

When light travels from a rarer medium to a denser one, it bends towards the normal ($i > r$) and when travels from a denser medium to a rarer one. it bends away from the normal ($i < r$).

Where, i = Angle of incidence

and r = Angle of refraction

We can see refraction in our daily life, some of the examples are given below :

The bottom of a tank or pond containing water appears to be raised due to refraction of light which takes place when light rays pass from the pool of water into the air. The letters appear to be raised when viewed through a glass slab placed over the document because of refraction of light.

When a light ray enters in a glass slab, then the emergent ray is parallel to the incident ray but it is shifted sideward slightly.

In this case, refraction takes place twice, first when ray enters glass slab from air and second when exits from glass slab to air.

- (i) What do you mean by optically rarer and denser medium ?
- (ii) What is the cause of refraction ?
- (iii) Draw a ray diagram showing refraction through a glass slab.

or

- (iv) Give one example of refraction from our daily life experience other than the two examples given above.