

ಕರ್ನಾಟಕ ಸರ್ಕಾರ
ರಾಮನಗರ ಜಿಲ್ಲಾ ಪಂಚಾಯತ್
ಉಪನಿರ್ದೇಶಕರ ಕಛೇರಿ, ಶಾಲಾ ಶಿಕ್ಷಣ ಮತ್ತು ಸಾಕ್ಷರತಾ ಇಲಾಖೆ, ರಾಮನಗರ.

ಯಶಸ್ಸು

ಎಸ್ ಎಸ್ ಎಲ್ ಸಿ ಗಣಿತ ಪ್ರಶ್ನೋತ್ತರ ಮಾಲಿಕೆ : 2022-23

ಮಾರ್ಗದರ್ಶಕರು :	
 ಶ್ರೀ ಗಂಗಳ್ಳಿಸ್ವಾಮಿ ಮಾನ್ಯ ಉಪನಿರ್ದೇಶಕರು (ಆಡಳಿತ) ರಾಮನಗರ ಜಿಲ್ಲೆ	 ಶ್ರೀ ಸೂರ್ಯಪ್ರಕಾಶ್‌ಮೂರ್ತಿ ಎ ಮಾನ್ಯ ಉಪನಿರ್ದೇಶಕರು(ಅಭಿವೃದ್ಧಿ) ರಾಮನಗರ ಜಿಲ್ಲೆ
 ಶ್ರೀಮತಿ ಮಂಜುಳಕುಮಾರಿ ಬಿ.ಜಿ. ಶಿಕ್ಷಣಾಧಿಕಾರಿಗಳು ಉಪನಿರ್ದೇಶಕರ ಕಛೇರಿ ರಾಮನಗರ ಜಿಲ್ಲೆ	 ಶ್ರೀ ಜಮೀರ್ ಪಾಷಾ ಶಿಕ್ಷಣಾಧಿಕಾರಿಗಳು ಉಪನಿರ್ದೇಶಕರ ಕಛೇರಿ ರಾಮನಗರ ಜಿಲ್ಲೆ
 ಶ್ರೀಮತಿ ಇಶ್ರತ್ ಜಹಾನ್ ಗಣಿತ ವಿಷಯ ಪರಿವೀಕ್ಷಕರು ಉಪನಿರ್ದೇಶಕರ ಕಛೇರಿ ರಾಮನಗರ ಜಿಲ್ಲೆ	
ಸಂಪನ್ಮೂಲ ತಂಡ :	
 ಶ್ರೀ ಮಹದೇವಯ್ಯ ಎಲ್. ಸಿ ಸಹ ಶಿಕ್ಷಕರು ಸರ್ಕಾರಿ ಪ್ರೌಢಶಾಲೆ ಬಿಳಗುಂಬ ರಾಮನಗರ ತಾ ಮತ್ತು ಜಿ	 ಶ್ರೀ ಚಕ್ರಪಾಣಿ ಬಿ.ಎ ಸಹ ಶಿಕ್ಷಕರು ಸರ್ಕಾರಿ ಪ್ರೌಢಶಾಲೆ ಹೂಕುಂದ ಕನಕಪುರ ತಾ , ರಾಮನಗರ ಜಿ
 ಶ್ರೀ ಅನಿಲ್‌ಕುಮಾರ್ ಸಿ.ಎನ್ ಸಹ ಶಿಕ್ಷಕರು ಸರ್ಕಾರಿ ಪ್ರೌಢಶಾಲೆ ಅರಳಾಳುಸಂದ್ರ ರಾಮನಗರ ತಾ ಮತ್ತು ಜಿ	 ಶ್ರೀ ವೇಣುಗೋಪಾಲ್ ಎಸ್. ಸಹ ಶಿಕ್ಷಕರು ಸರ್ಕಾರಿ ಪ್ರೌಢಶಾಲೆ ಕ್ಯಾಸಾಪುರ ರಾಮನಗರ ತಾ ಮತ್ತು ಜಿ
 ಶ್ರೀ ರಾಜಣ್ಣ ಸಿ. ಸಹ ಶಿಕ್ಷಕರು ಶ್ರೀ ನರಸಿಂಹಸ್ವಾಮಿ ಗ್ರಾಮಾಂತರ ವಸತಿ ಪ್ರೌಢಶಾಲೆ, ಬಿಸ್ಕೂರು ಮಾಗಡಿ ತಾ , ರಾಮನಗರ ಜಿ	 ಶ್ರೀ ವಿನಯಕುಮಾರ್ ಎಸ್. ಸಹ ಶಿಕ್ಷಕರು ಕರ್ನಾಟಕ ಪಬ್ಲಿಕ್ ಶಾಲೆ ಅರಳಾಳುಸಂದ್ರ ಚನ್ನಪಟ್ಟಣ ತಾ , ರಾಮನಗರ ಜಿ

Theme base marks distribution : 2022-23

SL. No.	THEMES	UNITS	MARKS
1	NUMBER SYSTEM	REAL NUMBERS	4
2	ALGEBRA	PAIR OF LINEAR EQUATIONS IN TWO VARIABLES	26
		ARITHMETIC PROGRESSION	
		POLYNOMIALS	
		QUADRATIC EQUATIONS	
3	TRIGONOMETRY	INTRODUCTION TO TRIGONOMETRY	9
		SOME APPLICATIONS OF TRIGONOMETRY	
4	COORDINATE GEOMETRY	COORDINATE GEOMETRY	5
5	STATISTICS AND PROBABILITY	STATISTICS	9
		PROBABILITY	
6	GEOMETRY	TRIANGLES	17
		CIRCLES	
		CONSTRUCTIONS	
7	(MENSURATION) SURFACE AREA AND VOLUME	AREA RELATED TO CIRCLES	10
		SURFACE AREAS AND VOLUMES	
		Total	80
* Internal choice questions can be asked from the unit or from the theme.			

ಪ್ರಿಯ ವಿದ್ಯಾರ್ಥಿಗಳೇ ಮುಂದೆ ನೀಡಿರುವ ಗಣಿತದ ಸೂತ್ರಗಳು ಹಾಗೂ ಮಾದರಿ ಲೆಕ್ಕಗಳನ್ನು ನಿಯಮಿತವಾಗಿ ಅಭ್ಯಾಸ ಮಾಡುವ ಮೂಲಕ ಗಣಿತವನ್ನು ಸುಲಭವಾಗಿ ಕಲಿತು ಏಪ್ರಿಲ್ - 2023ರ ವಾರ್ಷಿಕ ಪರೀಕ್ಷೆಗೆ ಉತ್ತಮವಾಗಿ ಪೂರ್ವಸಿದ್ಧತೆ ಮಾಡಿಕೊಳ್ಳಿ. ಸಮರೂಪ ತ್ರಿಭುಜಗಳು ಮತ್ತು ಸ್ಪರ್ಶಕಗಳ ರಚನೆಗಳು, ಪ್ರಮೇಯ, ಗ್ರಾಫ್, ಓಜೀವ್, ಸರಾಸರಿ/ಬಹುಲಕ/ಮಧ್ಯಾಂಕದ ಟೇಬಲ್ ಲೆಕ್ಕ, ಹಾಗೂ ಕೆಲವು ಆಯ್ದು ಮುಖ್ಯ ಪರಿಕಲ್ಪನೆಗಳಿಗೆ ಸಂಬಂಧಿಸಿದಂತೆ ಅಭ್ಯಾಸದ ಹಿತ ದೃಷ್ಟಿಯಿಂದ ಸೂತ್ರಗಳು ಮತ್ತು ಮಾದರಿ ಪ್ರಶ್ನೆಗಳನ್ನು ನೀಡಲಾಗಿದೆ. ಇವುಗಳನ್ನು ಬಿಡಿಸಿ, ಪುನರಾವರ್ತನೆ ಮಾಡಿಕೊಳ್ಳಿ. ಕೆಲವು ಲೆಕ್ಕಗಳಿಗೆ ಮಾದರಿ ಉತ್ತರಗಳನ್ನು ನೀಡಲಾಗಿದೆ. ಲೆಕ್ಕಗಳನ್ನು ಬಿಡಿಸುವಾಗ 2, 3, 4 ಮತ್ತು 5 ಅಂಕದ ಪ್ರಶ್ನೆಗಳಿಗೆ ಹಂತಗಳನ್ನು ಅನುಸರಿಸಿ. ಇದರಿಂದ ಅಂಕ ಗಳಿಕೆಗೆ ಸಹಕಾರಿ ಆಗುತ್ತದೆ. ಜೊತೆಗೆ ಪಠ್ಯ ಪುಸ್ತಕದ ಉದಾಹರಣೆ ಲೆಕ್ಕಗಳು ಮತ್ತು ಅಭ್ಯಾಸ ಲೆಕ್ಕಗಳನ್ನು ಚೆನ್ನಾಗಿ ಅಭ್ಯಸಿಸುವುದು. ಗಣಿತದಲ್ಲಿ ಪರ್ಯಾಯ ವಿಧಾನದ ಸರಿಯಾದ ಉತ್ತರಗಳಿಗೆ ಪೂರ್ಣ ಅಂಕಗಳನ್ನು ನೀಡಲಾಗುತ್ತದೆ. ಈ ಬಗ್ಗೆ ಗೊಂದಲ ಬೇಡ. ಬರೆದು ಅಭ್ಯಾಸ ಮಾಡುವ ರೂಢಿಯಿದ್ದರೆ ಪರೀಕ್ಷೆಯಲ್ಲಿಯೂ ಸುಲಭವಾಗಿ ಬರೆಯಬಲ್ಲರಿ. ನಿಮ್ಮ ಪ್ರಯತ್ನಕ್ಕೆ ಉತ್ತಮ ಪ್ರತಿಫಲ ಸಿಗಲಿ ಎಂದು ಆಶಿಸುತ್ತೇವೆ.

ಧನ್ಯವಾದಗಳೊಂದಿಗೆ,

ಸಂಪನ್ಮೂಲ ತಂಡ

VERY IMPORTANT FORMULAE / STATEMENTS

ARITHMETIC PROGRESSIONS

- 1) General form of arithmetic progression $a, (a + d), (a + 2d), \dots \dots a + (n - 1)d$
- 2) n^{th} term of arithmetic progression $a_n = a + (n - 1)d$
- 3) n^{th} term from last of an AP is $l - (n - 1)d$
- 4) The relation between any two terms of an AP is $a_p = a_q + (p - q)d$
- 5) Common difference of AP, $d = \frac{a_p - a_q}{p - q}$ (when any 2 terms are given)
- 6) Common difference of AP, $d = a_2 - a_1$ or $d = \frac{a_n - a}{n - 1}$
- 7) The sum of first n positive integers $S_n = \frac{n(n+1)}{2}$
- 8) The sum of first n odd natural numbers $S_n = n^2$
- 9) The sum of first n even natural numbers $S_n = n(n + 1)$
- 10) Sum of first n terms of an AP $S_n = \frac{n}{2} [2a + (n - 1)d]$
- 11) Sum of first n terms of an AP $S_n = \frac{n}{2} [a + a_n]$ or $S_n = \frac{n}{2} [a + l]$
- 12) In any progression $S_n - S_{n-1} = a_n$
- 13) If a, b, c are in AP, then the arithmetic mean between a and c is given by $b = \frac{a+c}{2}$

SIMILAR TRIANGLES

- 14) In $\triangle ABC$ if $DE \parallel BC$ then

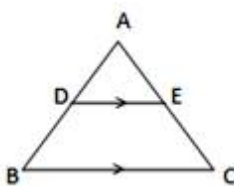

Thales theorem	corollary of Thales theorem	corollary of Thales theorem
$\frac{AD}{DB} = \frac{AE}{EC}$	$\frac{AD}{AB} = \frac{AE}{AC} = \frac{DE}{BC}$	$\frac{DB}{AB} = \frac{EC}{AC}$

- 15) In the given fig. if $\triangle ABC \sim \triangle PQR$ then

$$\frac{ar(\triangle ABC)}{ar(\triangle PQR)} = \left(\frac{AB}{PQ}\right)^2 = \left(\frac{BC}{QR}\right)^2 = \left(\frac{AC}{PR}\right)^2 = \left(\frac{AM}{PN}\right)^2$$

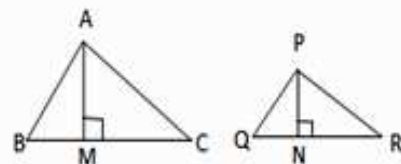

- 16) In right angled $\triangle ABC$ if $\angle ABC = 90^\circ$ then

$$AC^2 = AB^2 + BC^2 \quad (\text{Pythagoras Theorem})$$

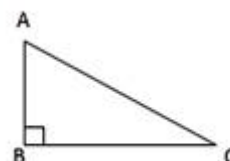

17)	Pythagorean Triplets	Details	Pythagorean Triplets	Details
	3, 4, 5	$3^2 + 4^2 = 5^2$	8, 15, 17	$8^2 + 15^2 = 17^2$
	6, 8, 10	$6^2 + 8^2 = 10^2$	12, 16, 20	$12^2 + 16^2 = 20^2$
	5, 12, 13	$5^2 + 12^2 = 13^2$	10, 24, 26	$10^2 + 24^2 = 26^2$

PAIR OF LINEAR EQUATIONS IN TWO VARIABLES

18) Standard form of linear equation in one variable $ax + b = 0$ (here $a \neq 0$)

19) Standard form of linear equation in two variables $ax + by + c = 0$ (here $a^2 + b^2 \neq 0$)

20) The general form for a pair of linear equations in two variables x and y is

$$\left. \begin{array}{l} a_1x + b_1y + c_1 = 0 \\ a_2x + b_2y + c_2 = 0 \end{array} \right\} \begin{array}{l} \text{Here } a_1, b_1, c_1, a_2, b_2, c_2 \text{ are all real numbers} \\ \text{and } a_1^2 + b_1^2 \neq 0, a_2^2 + b_2^2 \neq 0 \end{array}$$

21) $a_1x + b_1y + c_1 = 0$

$a_2x + b_2y + c_2 = 0$ The lines represented by these equations

❖ Intersect if $\frac{a_1}{a_2} \neq \frac{b_1}{b_2}$ and pair of equations has a unique solution.

❖ Coincide if $\frac{a_1}{a_2} = \frac{b_1}{b_2} = \frac{c_1}{c_2}$ and pair of equations has infinitely many solutions.

❖ Are parallel if $\frac{a_1}{a_2} = \frac{b_1}{b_2} \neq \frac{c_1}{c_2}$ and pair of equations has no solution.

22) For the pair of linear equations $a_1x + b_1y + c_1 = 0$ and $a_2x + b_2y + c_2 = 0$ the equation used to find solutions by Cross Multiplication Method is

$$\frac{x}{b_1c_2 - b_2c_1} = \frac{y}{c_1a_2 - c_2a_1} = \frac{1}{a_1b_2 - a_2b_1}$$

OR

$$x = \frac{b_1c_2 - b_2c_1}{a_1b_2 - a_2b_1}, \quad y = \frac{c_1a_2 - c_2a_1}{a_1b_2 - a_2b_1}$$

CIRCLES

23) A line that intersects a circle at two distinct points is called a secant.

24) A line that intersects a circle at only one point is called a tangent.

- 25) The tangent to a circle is a special case of the secant, when the two end points of its corresponding chord coincide.
- 26) The tangent at any point of a circle is perpendicular to the radius through the point of contact.
- 27) The length of tangents drawn from an external point to a circle are equal.
- 28) The length of the tangent drawn from an external point at a distance of 'd' units from the center of the circle of radius 'r' is given by $t = \sqrt{d^2 - r^2}$

AREAS RELATED TO CIRCLES

- 29) Length of the circumference of a circle of radius r , $= 2\pi r$
- 30) Length of the circumference of a circle of diameter d , $= \pi d$
- 31) Area of a circle of radius r , $= \pi r^2$ sq.units
- 32) Area of the quadrant of a circle of radius r , $= \frac{1}{4}\pi r^2$ sq.units
- 33) Area of the sector of angle θ , $= \frac{\theta}{360} \times \pi r^2$ sq.units
- 34) Length of an arc of a sector of angle θ , $= \frac{\theta}{360} \times 2\pi r$ units
- 35) Area of the segment of a circle = (Area of the corresponding sector - Area of the corresponding triangle).

CONSTRUCTIONS

- 36) In the given fig. the angle between the tangents

$$\angle APB = 180^\circ - \angle AOB$$

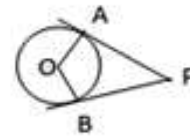

- 37) In a circle the point of intersection of the perpendicular bisectors of two non-parallel chords is the center of the circle.

COORDINATE GEOMETRY

- 38) Distance between the points $P(x_1, y_1)$ and $Q(x_2, y_2)$ is $PQ = \sqrt{(x_2 - x_1)^2 + (y_2 - y_1)^2}$
or $PQ = \sqrt{(x_1 - x_2)^2 + (y_1 - y_2)^2}$
- 39) Distance of a point $P(x, y)$ from the origin is given by $\sqrt{x^2 + y^2}$
- 40) The coordinates of the point $P(x, y)$ which divides the line segment joining the points $A(x_1, y_1)$ and $B(x_2, y_2)$ internally in the ratio $m_1 : m_2$ are $\left(\frac{m_1 x_2 + m_2 x_1}{m_1 + m_2}, \frac{m_1 y_2 + m_2 y_1}{m_1 + m_2} \right)$
- 41) The coordinates of the mid-point of the line segment joining the points $P(x_1, y_1)$ and $Q(x_2, y_2)$ are $\left(\frac{x_1 + x_2}{2}, \frac{y_1 + y_2}{2} \right)$

42) Area of the triangle whose vertices are (x_1, y_1) , (x_2, y_2) and (x_3, y_3) is

$$\frac{1}{2} [x_1(y_2 - y_3) + x_2(y_3 - y_1) + x_3(y_1 - y_2)] \text{ sq.units}$$

REAL NUMBERS

43) Euclid's Division Lemma : Given positive integers a and b , there exist unique integers q and r satisfying $a = bq + r$, $0 \leq r < b$.

44) For any two positive integers a and b , $\text{HCF}(a, b) \times \text{LCM}(a, b) = a \times b$.

45) If $x = \frac{p}{q}$ (here p, q are co-primes) is a rational number which has a terminating decimal expansion then q is of the form $2^n \times 5^m$ (n, m are non-negative integers)

POLYNOMIALS

46) A polynomial of degree 1 is called a linear polynomial.

47) A polynomial of degree 2 is called a quadratic polynomial.

48) A polynomial of degree 3 is called a cubic polynomial.

49) The general form of a linear polynomial in x is of the form $ax + b$, where a, b are real numbers and $a \neq 0$

50) The general form of a quadratic polynomial in x is of the form $ax^2 + bx + c$, where a, b, c are real numbers and $a \neq 0$

51) The general form of a cubic polynomial in x is of the form $ax^3 + bx^2 + cx + d$, where a, b, c, d are real numbers and $a \neq 0$

52) The zero of a linear polynomial $ax + b$ is $= \frac{-b}{a}$

53) If α and β are the zeros of the quadratic polynomial $ax^2 + bx + c$, $a \neq 0$ then

$$\text{❖ Sum of zeros } \alpha + \beta = \frac{-b}{a}$$

$$\text{❖ Product of zeros } \alpha \beta = \frac{c}{a}$$

54) If α, β and γ are the zeros of a cubic polynomial $ax^3 + bx^2 + cx + d$ then,

$\alpha + \beta + \gamma = \frac{-b}{a}$	$\alpha\beta + \beta\gamma + \gamma\alpha = \frac{c}{a}$	$\alpha\beta\gamma = \frac{-d}{a}$
--	--	------------------------------------

55) Quadratic polynomial with α and β as its zeros is $x^2 - (\alpha + \beta)x + \alpha\beta$.

56) Cubic polynomial with α, β and γ as its zeros is

$$x^3 - (\alpha + \beta + \gamma)x^2 + (\alpha\beta + \beta\gamma + \gamma\alpha)x - \alpha\beta\gamma$$

57) A linear polynomial has only one zero.

58) A quadratic polynomial can have atmost 2 zeros.

- 59) A cubic polynomial can have atmost 3 zeros.
- 60) A cubic polynomial has at least one zero.
- 61) A polynomial of degree 'n' has atmost n zeros .
- 62) The graph of a linear polynomial is a straight line.
- 63) The graph of a quadratic polynomial is called parabola.
- 64) In the quadratic polynomial $ax^2 + bx + c$ if $a > 0$, then its graph opens upwards.
- 65) In the quadratic polynomial $ax^2 + bx + c$ if $a < 0$, then its graph opens downwards.
- 66) In the quadratic polynomial $ax^2 + bx + c$ if $a = c$, then the zeros are reciprocals to each other .
- 67) Division Algorithm for polynomials is given by $p(x) = g(x)q(x) + r(x)$
- 68) In polynomial division : Divisor $g(x) = \frac{p(x) - r(x)}{q(x)}$

QUADRATIC EQUATIONS

- 69) The standard form of a quadratic equation in x is $ax^2 + bx + c = 0$
here a, b, c are real numbers and $a \neq 0$
- 70) Formula used to find the roots of a quadratic equation is $x = \frac{-b \pm \sqrt{b^2 - 4ac}}{2a}$
- 71) Discriminant of a quadratic equation is $b^2 - 4ac$
- 72) A quadratic equation $ax^2 + bx + c = 0$ has
- ❖ two distinct real roots , if $b^2 - 4ac > 0$,
 - ❖ two equal real roots , if $b^2 - 4ac = 0$,
 - ❖ no real roots , if $b^2 - 4ac < 0$.
- 73) In quadratic equation $ax^2 + bx + c = 0$ if $b^2 - 4ac = 0$
then the roots of the equation are $x = \frac{-b}{2a}$ or $x = \frac{-b}{2a}$
- 74) In quadratic equation $ax^2 + bx + c = 0$ if $b = 0$ then the roots are additive inverse.
- 75) In quadratic equation $ax^2 + bx + c = 0$ if $a = c$ then the roots are reciprocals to each other .
- 76) In quadratic equation $ax^2 + bx + c = 0$ if $c = 0$ then one of the roots will be zero.
- 77) In quadratic equation $ax^2 + bx + c = 0$ if $\frac{1}{2}b = \sqrt{ac}$ then the roots are equal.

INTRODUCTION TO TRIGONOMETRY

78) The trigonometric ratios of acute angle $\angle A$ in the given right triangles .

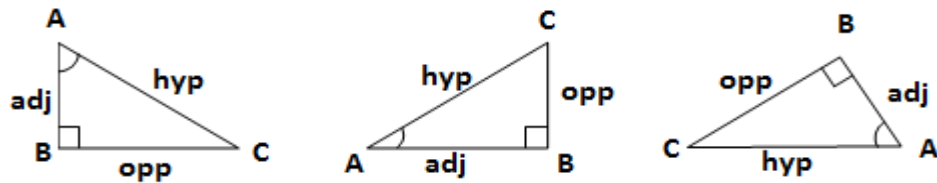

Trigonometric ratios of acute angle $\angle A$		
$\sin A = \frac{\text{opp}}{\text{hyp}}$	$\cos A = \frac{\text{adj}}{\text{hyp}}$	$\tan A = \frac{\text{opp}}{\text{adj}}$
$\text{cosec } A = \frac{\text{hyp}}{\text{opp}}$	$\sec A = \frac{\text{hyp}}{\text{adj}}$	$\cot A = \frac{\text{adj}}{\text{opp}}$
Reciprocals of trigonometric ratios		
$\sin A = \frac{1}{\text{cosec } A}$	$\cos A = \frac{1}{\sec A}$	$\tan A = \frac{1}{\cot A}$
$\text{cosec } A = \frac{1}{\sin A}$	$\sec A = \frac{1}{\cos A}$	$\cot A = \frac{1}{\tan A}$

79) $\tan A = \frac{\sin A}{\cos A}$ and $\cot A = \frac{\cos A}{\sin A}$

80) Trigonometric ratios of some specific angles

$\angle A$	0°	30°	45°	60°	90°
$\sin A$	0	$\frac{1}{2}$	$\frac{1}{\sqrt{2}}$	$\frac{\sqrt{3}}{2}$	1
$\cos A$	1	$\frac{\sqrt{3}}{2}$	$\frac{1}{\sqrt{2}}$	$\frac{1}{2}$	0
$\tan A$	0	$\frac{1}{\sqrt{3}}$	1	$\sqrt{3}$	N. D
$\text{cosec } A$	N. D	2	$\sqrt{2}$	$\frac{2}{\sqrt{3}}$	1
$\sec A$	1	$\frac{2}{\sqrt{3}}$	$\sqrt{2}$	2	N. D
$\cot A$	N. D	$\sqrt{3}$	1	$\frac{1}{\sqrt{3}}$	0

81) Trigonometric Ratios of Complementary angles

$$\sin(90^\circ - A) = \cos A \quad \text{or} \quad \cos(90^\circ - A) = \sin A$$

$$\tan(90^\circ - A) = \cot A \quad \text{or} \quad \cot(90^\circ - A) = \tan A$$

$$\operatorname{cosec}(90^\circ - A) = \sec A \quad \text{or} \quad \sec(90^\circ - A) = \operatorname{cosec} A$$

Trigonometric Identities

$$82) \sin^2 A + \cos^2 A = 1$$

$$83) 1 + \tan^2 A = \sec^2 A \quad \text{or} \quad \sec^2 A - \tan^2 A = 1$$

$$84) 1 + \cot^2 A = \operatorname{cosec}^2 A \quad \text{or} \quad \operatorname{cosec}^2 A - \cot^2 A = 1$$

$$85) \sin^2 A = 1 - \cos^2 A = (1 + \cos A)(1 - \cos A)$$

$$86) \cos^2 A = 1 - \sin^2 A = (1 + \sin A)(1 - \sin A)$$

$$87) \sin A = \sqrt{1 - \cos^2 A}$$

$$88) \cos A = \sqrt{1 - \sin^2 A}$$

SOME APPLICATIONS OF TRIGONOMETRY

89) In right triangle ABC if $\angle A = \theta$ is an acute angle then

$$\text{❖ Height } h = \tan \theta \times d$$

$$\text{❖ distance } d = \cot \theta \times h$$

$$\text{❖ slant height } x = \frac{h}{\sin \theta} \quad \text{or} \quad x = \frac{d}{\cos \theta}$$

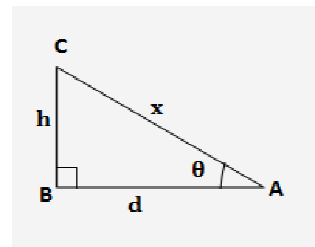
**STATISTICS**

$$90) \text{ Mid-point or Class mark} = \frac{\text{Upper class limit} + \text{Lower class limit}}{2}$$

91) Formula to find the Mean of Grouped data

$$\text{❖ Direct Method : Mean } \bar{x} = \frac{\sum f_i x_i}{\sum f_i}$$

$$\text{❖ Assumed Mean Method : Mean } \bar{x} = a + \frac{\sum f_i d_i}{\sum f_i}$$

$$\text{❖ Step-deviation Method : Mean } \bar{x} = a + \left(\frac{\sum f_i u_i}{\sum f_i} \right) \times h$$

92) Formula to find the Mode of Grouped data

$$\text{❖ Mode} = l + \left[\frac{f_1 - f_0}{2f_1 - f_0 - f_2} \right] \times h$$

93) Formula to find the Median of Grouped data

$$\text{❖ Median} = l + \left[\frac{\frac{n}{2} - cf}{f} \right] \times h$$

94) Empirical relationship between the three measures of central tendency :

- ❖ $3 \text{ Median} = \text{Mode} + 2 \text{ Mean.}$
- ❖ $\text{Mode} = 3 \text{ Median} - 2 \text{ Mean.}$
- ❖ $2 \text{ Mean} = 3 \text{ Median} - \text{Mode.}$

PROBABILITY

95) Probability of an event $P(E) = \frac{n(E)}{n(S)}$

- here $n(E)$ is number of outcomes favourable to E and
- $n(S)$ is number of all possible outcomes .

96) The probability of a sure event (or certain event) is 1.

97) The probability of an impossible event is 0.

98) The probability of an event, $P(E)$ is a number such that $0 \leq P(E) \leq 1$.

99) An event having only one outcome is called an elementary event.

100) The sum of the probabilities of all the elementary events of an experiment is 1.

101) If E and (\bar{E}) are complementary events , then $P(E) + P(\bar{E}) = 1$.

102) If a coin is tossed once then the sample space $S = \{ H, T \} \therefore n(S) = 2$

103) If two coins are tossed simultaneously then the sample space

$$S = \{ HH, HT, TH, TT \} \therefore n(S) = 4$$

104) If three coins are tossed simultaneously then the sample space

$$S = \{ HHH, HHT, HTH, HTT, THH, THT, TTH, TTT \} \therefore n(S) = 8$$

105) If a die is thrown once then the sample space $S = \{ 1, 2, 3, 4, 5, 6 \} \therefore n(S) = 6$

106) If two unbiased dice are thrown simultaneously then the total outcomes
 $n(S) = 36$.

SURFACE AREAS AND VOLUMES

107) Table containing the formulae used to find the surface areas and volumes of solids

SOLIDS	LSA	TSA	VOLUME
CUBE	$4a^2$	$6a^2$	a^3
CUBOID	$2h(l + b)$	$2(lb + bh + hl)$	$l \times b \times h$
CYLINDER	$2\pi rh$	$2\pi r(h + r)$	$\pi r^2 h$
CONE	πrl	$\pi r(l + r)$	$\frac{1}{3} \pi r^2 h$
SPHERE	$4\pi r^2$	$4\pi r^2$	$\frac{4}{3} \pi r^3$
HEMISPHERE	$2\pi r^2$	$3\pi r^2$	$\frac{2}{3} \pi r^3$
FRUSTUM of a CONE	$\pi l(r_1 + r_2)$	$\pi l(r_1 + r_2) + \pi(r_1^2 + r_2^2)$	$\frac{1}{3} \pi h (r_1^2 + r_2^2 + r_1 r_2)$

108) Perimeter of the base of cylinder / cone / hemisphere = $2\pi r$

109) Slant height of a Cone $l = \sqrt{r^2 + h^2}$

110) Slant height of frustum of a cone $l = \sqrt{h^2 + (r_1 - r_2)^2}$

UNIT – 1 : ARITHMETIC PROGRESSION

1 Mark Questions (MCQ)

- Which of the following is an AP ?
 A) 2, 4, 8, 16
 B) 2, $\frac{5}{2}$, 3, $\frac{7}{2}$,
 C) 1, 3, 9, 27
 D) 1, 3, 4, 6
- If a, b and c are in AP, then $\frac{b-a}{c-b}$ is
 A) $\frac{b}{a}$ B) 0 C) 1 D) 2a
- $\frac{3}{2}, \frac{1}{2}, -\frac{1}{2}, -\frac{3}{2}, \dots$ Common difference of this AP
 A) -1 B) $\frac{1}{2}$ C) $-\frac{1}{2}$ D) $\frac{2}{3}$
- 10, 7, 4, 30th term of this AP
 A) 97 B) 77 C) -77 D) -87

- 5) $-3, -\frac{1}{2}, 2, \dots$ 11th term of this AP is
 A) 28 B) 22 C) - 38 D) $-48\frac{1}{2}$
- 6) In an AP if $a_n = 3 + 4n$ then the value of a_3 is
 A) 15 B) 9 C) 12 D) 13
- 7) In an AP if $S_n = 4n - n^2$ then d is
 A) 2 B) 1 C) - 2 D) - 1
- 8) In an AP if $S_5 = 30$ and $S_4 = 20$ then a_5 is
 A) 10 B) 50 C) 20 D) 9
- 9) If $a_7 = 6$ in an AP of 13 terms then the value of S_{13} is
 A) 42 B) 24 C) 87 D) 78
- 10) The sum of first 50 odd natural numbers is
 A) 250 B) 500 C) 2500 D) 5000

1 Mark Questions (VSA)

- 11) Write the nth term of an AP whose first term is a and common difference is d .
- 12) In an AP if $a_n = 3 + 2n$ then find a_4 .
- 13) If $- 3, a, 2$ are the three consecutive terms of an AP then find a .
- 14) $\sqrt{2}, \sqrt{8}, \sqrt{18}, \dots$ write the next term of this AP.
- 15) Who is the famous mathematician who easily calculated the sum of first 100 natural numbers ?
- 16) If a, b and c are in AP ,then find $(c - b) - (b - a)$.

	1) B	2) C	3) A	4) C	5) B	6) A	7) C	8) A	9) D	10) C
Ans	11) $a_n = a + (n - 1)d$			12) $a_4 = 11$		13) $-\frac{1}{2}$	14) $\sqrt{32}$	15) Gauss		16) 0

2 Marks Questions (SA)

- 17) In an AP 2 , 7, 12 ,find the 10th term.
 Solution: In this AP $a = 2$ and $d = a_2 - a_1 = 7 - 2 = 5, a_{10} = ?$
 $a_n = a + (n - 1)d$
 $a_{10} = 2 + (10 - 1)5$
 $a_{10} = 2 + 9 \times 5$
 $a_{10} = 2 + 45$
 $\therefore a_{10} = 47$
- 18) In an AP 21 , 18, 15, find 35th term .
- 19) In an AP 3 ,8, 13 ,find 10th term .
- 20) In an AP 10, 7, 4,find 30th term .
- 21) In an AP $- 3, -\frac{1}{2}, 2, \dots$ find 11th term .

22) In an AP 10, 7, 4,-62 find 11th term from last .

Solution : In this AP $d = a_2 - a_1 = 7 - 10 = -3$ and $l = -62$

11th term from last = ?

n^{th} term of an AP from last = $l - (n - 1)d$

11th term of this AP from last = $-62 - (11 - 1)(-3)$

11th term of this AP from last = $-62 - (10)(-3)$

11th term of this AP from last = $-62 + 30$

\therefore 11th term of this AP from last = -32

23) In an AP 3, 8, 13,253 find 20th term from last .

24) In an AP 21, 18, 15, -81 find 28th term from last .

25) Which term of the AP 21, 18, 15, is -81 ?

Solution : Here $a = 21$ and $d = a_2 - a_1 = 18 - 21 = -3$, $a_n = -81, n = ?$

$a_n = a + (n - 1)d$

$-81 = 21 + (n - 1)(-3)$

$-81 = 21 - 3n + 3$

$3n = 24 + 81$

$3n = 105$

$n = \frac{105}{3}$

$\therefore n = 35$

\therefore 35th term of the given AP is -81 .

26) Which term of the AP 3, 8, 13, is 78 ?

27) Which term of the AP 7, 13, 19,is 205 ?

28) Find the sum of the AP 8, 3, -2,upto 22 terms .

Solution : $a = 8$, $S_{22} = ?$

$d = a_2 - a_1 = 3 - 8 = -5$

$S_n = \frac{n}{2} [2a + (n - 1) d]$

$S_{22} = \frac{22}{2} [2(8) + (22 - 1)(-5)]$

$S_{22} = 11[16 + 21(-5)]$

$S_{22} = 11[16 - 105]$

$S_{22} = 11 \times -89$

$S_{22} = -979$

29) Find the sum of the AP 2, 7, 12,upto 10 terms .

30) Find the sum of the AP - 37, -33, -29,upto 12 terms .

3 Marks Questions (LA-1)

31) In an AP if the first term is 38 and 16th term is 73 then find its 31st term .

Solution : Here $a_1 = 38$ and $a_{16} = 73$ then $a_{31} = ?$

$$\text{In an AP } d = \frac{a_p - a_q}{p - q}$$

$$d = \frac{a_{16} - a_1}{16 - 1}$$

$$d = \frac{73 - 38}{15} = \frac{35}{15} = \frac{7}{3}$$

$$a_{31} = a_1 + 30d$$

$$a_{31} = 38 + 30\left(\frac{7}{3}\right)$$

$$a_{31} = 38 + 70$$

$$a_{31} = 108$$

32) In an AP if the 3rd term is 12 and 50th term is 106, then find its 29th term .

33) In an AP if the 3rd term is 4 and 9th term is -8, then find its 5th term .

34) Find the sum of first 40 positive integers divisible by 6

Solution : 6, 12, 18, 240 (\because 40th term is $40 \times 6 = 240$)

$$S_n = 6 + 12 + 18 + + 240$$

$$S_n = 6 (1 + 2 + 3 + + 40)$$

$$S_n = 6 \left[\frac{40 \times (40 + 1)}{2} \right] \quad (\because \text{sum of first } n \text{ natural numbers } S_n = \frac{n(n+1)}{2})$$

$$S_n = 6 \times 20 \times 41$$

$$S_n = 120 \times 41$$

$$S_n = 4920$$

\therefore the sum of first 40 positive integers divisible by 6 is 4920.

Alternate Method

Solution : 6, 12, 18, (upto 40 terms)

$$a = 6, \quad S_{40} = ?$$

$$d = a_2 - a_1 = 12 - 6 = 6$$

$$S_n = \frac{n}{2} [2a + (n - 1) d]$$

$$S_{40} = \frac{40}{2} [2(6) + (40 - 1)(6)]$$

$$S_{40} = 20 [12 + 39(6)]$$

$$S_{40} = 20 [12 + 234]$$

$$S_{40} = 20 \times 246$$

$$S_{40} = 4920$$

\therefore the sum of first 40 positive integers divisible by 6 is 4920.

35) Find the sum of first 15 multiples of 8 .

36) Find the sum of multiples of 7 between 100 and 200 .

$$\text{Solution : } S_n = 105 + 112 + 119 + \dots + 196$$

$$S_n = 7(15 + 16 + 17 + \dots + 28)$$

$$S_n = 7 \left[\frac{28 \times (28 + 1)}{2} - \frac{14 \times (14 + 1)}{2} \right] \quad (\because \text{sum of first } n \text{ natural numbers } S_n = \frac{n(n+1)}{2})$$

$$S_n = 7[14 \times 29 - 7 \times 15]$$

$$S_n = 7[406 - 105]$$

$$S_n = 7 \times 301$$

$$S_n = 2107$$

\therefore the sum of multiples of 7 between 100 and 200 is 2107 .

Alternate Method

$$\text{Solution : } 105 + 112 + 119 + \dots + 196$$

$$a = 105, \quad l = a_n = 196, \quad S_n = ?$$

$$d = a_2 - a_1 = 112 - 105 = 7$$

$$a_n = a + (n - 1)d$$

$$196 = 105 + (n - 1)7$$

$$196 - 105 = 7n - 7$$

$$91 + 7 = 7n$$

$$98 = 7n$$

$$n = 14$$

$$S_n = \frac{n}{2} [a + l]$$

$$S_{14} = \frac{14}{2} [105 + 196]$$

$$S_{14} = 7 [301]$$

$$S_{14} = 2107$$

\therefore the sum of multiples of 7 between 100 and 200 is 2107 .

37) Find the sum of odd numbers between 0 and 50 .

38) Find the sum of the terms from 10th term to 20th term of AP 3, 7, 11, 15,.....

39) If 10 times the 10th term of an AP is equal to 15 times the 15th term, find the 25th term.

$$\text{Solution: In an AP } 10 \times a_{10} = 15 \times a_{15} \quad (\text{given})$$

$$10[a + (10 - 1)d] = 15[a + (15 - 1)d] \quad [\because a_n = a + (n - 1)d]$$

$$10(a + 9d) = 15(a + 14d)$$

$$10a + 90d = 15a + 210d$$

$$10a - 15a = 210d - 90d$$

$$-5a = 120d$$

$$a = -\frac{120}{5}d$$

$$a = -24d \quad \text{-----}>(1)$$

$$a_{25} = a + (25 - 1)d$$

$$a_{25} = a + 24d$$

$$a_{25} = -24d + 24d \quad (\because \text{from eqn. 1})$$

$$a_{25} = 0$$

- 40) The 8th term of an AP is zero. Prove that its 38th term is triple its 18th term.

Solution: In an AP $a_8 = 0$ (\because given)

$$a_{18} = a_8 + 10d \quad (\because a_p = a_q + (p - q)d)$$

$$a_{18} = 0 + 10d$$

$$a_{18} = 10d \quad \text{-----}>(1)$$

$$a_{38} = a_{18} + 20d \quad (\because a_p = a_q + (p - q)d)$$

$$a_{38} = 10d + 20d \quad (\because \text{from eqn. 1})$$

$$a_{38} = 30d$$

$$a_{38} = 3 \times 10d$$

$$a_{38} = 3 \times a_{18} \quad (\because \text{from eqn. 1})$$

\therefore Hence the 38th term is triple its 18th term

- 41) If S_n , the sum of first n terms of an AP is given by $S_n = (3n^2 - 4n)$, then find its 25th term.

Solution: In an AP $S_n = (3n^2 - 4n)$ and $a_{25} = ?$

$$S_{25} = (3 \times 25^2 - 4 \times 25)$$

$$S_{25} = (1875 - 100)$$

$$S_{25} = 1775 \quad \text{-----}>(1)$$

$$S_{24} = (3 \times 24^2 - 4 \times 24)$$

$$S_{24} = (1728 - 96)$$

$$S_{24} = 1632 \quad \text{-----}>(2)$$

$$S_{25} - S_{24} = a_{25} \quad (\because S_n - S_{n-1} = a_n)$$

$$S_{25} - S_{24} = 1775 - 1632$$

$$\therefore a_{25} = 143$$

4 Marks Questions (LA-2)

- 42) The 7th term of an AP is four times the 2nd term and the 12th term exceeds thrice the 4th term by 2. Find the progression.
- 43) Four numbers are in AP. The sum of extremes is 10 and the product of the means is 24. Find the numbers.
- 44) The sum of 4th and 8th terms of an AP is 24 and the sum of its 6th and 10th terms is 44. Find the sum of first three terms of the AP.
- 45) The sum of three positive integers in AP is 24 and their product is 480. Find the numbers.

- 46) Find three numbers in AP whose sum is 24 and the sum of whose squares is 224.
 47) Find the sum of first 10 terms of the AP whose 12th term is -13 and the sum of first 4 terms is 24.

- 48) Divide 32 in four parts such that they are in AP and the ratio of product of extremes to the product of means is 7:15. Find the numbers.

Note : When three terms are in an AP, the terms are $(a - d), a, (a + d)$

When Four terms are in an AP, the terms are $(a - 3d), (a - d), (a + d), (a + 3d)$

5 Marks Questions (LA-3)

- 49) Show that the sum of the first n even natural numbers is equal to $\left(1 + \frac{1}{n}\right)$ times the sum of the first n odd natural numbers.

Solution: Let S_1 denotes the sum of the first n even natural numbers.

$$S_1 = 2 + 4 + 6 + \dots \text{ up to } n \text{ terms}$$

$$a = 2, \quad d = 4 - 2 = 2, \quad n = n$$

$$S_1 = \frac{n}{2} [2a + (n - 1)d]$$

$$S_1 = \frac{n}{2} [2 \times 2 + (n - 1)2]$$

$$S_1 = \frac{2n}{2} [2 + n - 1]$$

$$S_1 = n(n + 1) \quad \text{----> (1)}$$

Let S_2 denotes the sum of the first n odd natural numbers.

$$S_2 = 1 + 3 + 5 + \dots \text{ up to } n \text{ terms}$$

$$a = 1, \quad d = 3 - 1 = 2, \quad n = n$$

$$S_2 = \frac{n}{2} [2a + (n - 1)d]$$

$$S_2 = \frac{n}{2} [2 \times 1 + (n - 1)2]$$

$$S_2 = \frac{2n}{2} [1 + n - 1]$$

$$S_2 = n^2 \quad \text{----> (2)}$$

$$\frac{S_1}{S_2} = \frac{n(n+1)}{n^2} \quad [\because \text{from eqn.(1) eqn. (2)}]$$

$$\frac{S_1}{S_2} = \frac{(n + 1)}{n}$$

$$\frac{S_1}{S_2} = \left(\frac{n}{n} + \frac{1}{n}\right)$$

$$\frac{S_1}{S_2} = \left(1 + \frac{1}{n}\right)$$

$$\text{Hence, } S_1 = \left(1 + \frac{1}{n}\right) S_2$$

- 14) State Converse of Pythagoras Theorem.
 15) Write the two conditions for two polygons of same number of sides to be similar.
 16) State Converse of Thales Theorem.
 17) The areas of two similar triangles are in the ratio 4:9. Find the ratio of their corresponding medians.

Ans	1)D	2)A	3)B	4)B	5)C	6)C	7)D	8)B	9) D	10)C	11)A
12)	If a line is drawn parallel to one side of a triangle to intersect the other two sides in distinct points, the other sides are divided in the same ratio.										
13)	In a right triangle, the square of the hypotenuse is equal to the sum of the squares of the other two sides.										
14)	In a triangle if square of one side is equal to the sum of the squares of the other two sides, then the angle opposite to the first side is a right angle.										
15)	All the corresponding angles of polygons are equal and all the corresponding sides are in the same proportion.										
16)	If a line divides any two sides of a triangle in the same ratio, then the line is parallel to the third side.										
17)	2:3										

2 Marks Questions (SA)

- 18) In the given fig. if $DE \parallel BC$ then find EC .

Solution : In $\triangle ABC$ $DE \parallel BC$

$AD = 1.5\text{cm}$, $DB = 3\text{cm}$ and $AE = 1\text{cm}$

$$\frac{AD}{DB} = \frac{AE}{EC} \quad (\text{Thales theorem})$$

$$\frac{1.5}{3} = \frac{1}{EC}$$

$$\frac{15}{30} = \frac{1}{EC}$$

$$\frac{1}{2} = \frac{1}{EC}$$

$$EC = 2\text{cm}$$

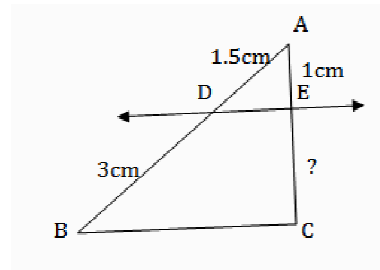

- 19) In the given fig. if $DE \parallel BC$, then find AD .

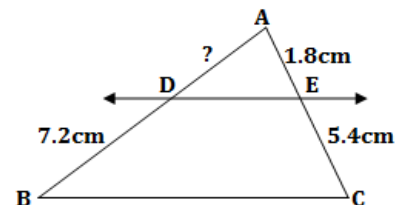

- 20) In $\triangle ABC$ $DE \parallel BC$, $AD = x + 1$, $DB = x - 1$
 $AE = x + 3$ and $EC = x$, find x.

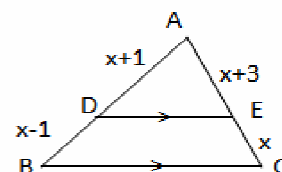

- 21) In the given fig. if $AQ \perp AB$, $PB \perp AB$, $AD = 20$ cm
 $BD = 12$ cm and $PB = 18$ cm then find AQ .

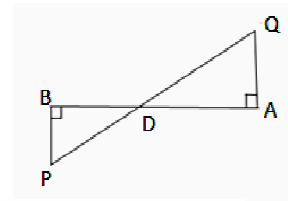

- 22) In the fig if $\frac{PS}{SQ} = \frac{PT}{TR}$ and $\angle PST = \angle PRQ$ then
 prove that ΔPQR is an isosceles triangle.

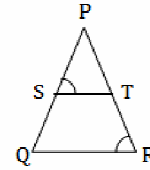

- 23) A vertical pole of height 6m casts a shadow 4m long on the ground and at the same time a tower casts a shadow 28m long. Find the height of the tower.
- 24) Let $\Delta ABC \sim \Delta DEF$ and their areas be respectively, 64cm^2 and 121cm^2 .
 If $EF = 15.4\text{cm}$, find BC .

Solution : $\Delta ABC \sim \Delta DEF$

$$\frac{\text{ar}(\Delta ABC)}{\text{ar}(\Delta DEF)} = \left(\frac{BC}{EF}\right)^2 \quad [\text{Theorem}]$$

$$\frac{64}{121} = \left(\frac{BC}{15.4}\right)^2$$

$$\left(\frac{8}{11}\right)^2 = \left(\frac{BC}{15.4}\right)^2$$

$$\frac{8}{11} = \frac{BC}{15.4}$$

$$11 \times BC = 15.4 \times 8$$

$$BC = \frac{15.4 \times 8}{11}$$

$$BC = 1.4 \times 8 = 11.2\text{cm}$$

- 25) In the fig. if $DE \parallel BC$ and $AD:DB = 5:4$, then find the ratios of areas of ΔADE and ΔABC .

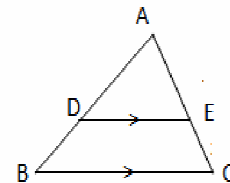

- 26) Diagonals of a trapezium ABCD with $AB \parallel CD$ intersect each other at the point O. If $AB = 2 CD$, find the ratio of the areas of ΔAOB and ΔCOD .

Solution : In trapezium ABCD, $AB \parallel DC$
 and diagonals intersect at O.

$$\Rightarrow AB = 2 CD \quad \frac{AB}{CD} = \frac{2}{1} \text{ ----} > (1)$$

In ΔAOB and ΔCOD

$$\angle A = \angle C \quad [\text{alternate angles}]$$

$$\angle B = \angle D \quad [\text{alternate angles}]$$

$$\Delta AOB \sim \Delta COD \quad [\text{AA similarity criterion}]$$

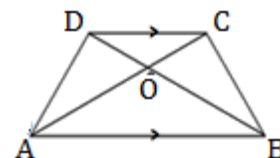

$$\frac{ar(\triangle AOB)}{ar(\triangle COD)} = \left(\frac{AB}{CD}\right)^2 \quad [\text{Theorem on areas}]$$

$$\frac{ar(\triangle AOB)}{ar(\triangle COD)} = \left(\frac{2}{1}\right)^2$$

$$\frac{ar(\triangle AOB)}{ar(\triangle COD)} = \frac{4}{1}$$

- 27) Diagonals AC and BD of a trapezium ABCD with $AB \parallel CD$ intersect each other at the point O.

Prove that $\frac{OA}{OC} = \frac{OB}{OD}$.

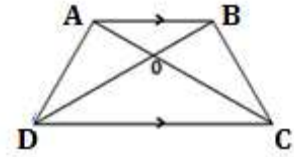

- 28) In $\triangle ABC$, D is a point on BC such that $\angle ADC = \angle BAC$. Prove that $CA^2 = CB \cdot CD$

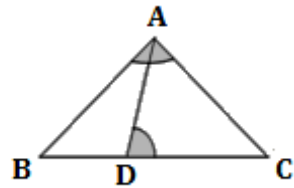

3 Marks Questions (LA -1)

- 29) Prove that the sum of the squares of the sides of a rhombus is equal to the sum of the squares of its diagonals.

Solution: In rhombus ABCD, $AB = BC = CD = AD$ [\because sides of rhombus are equal]

Diagonals AC and BD intersect perpendicularly at O.

$$\angle AOB = 90^\circ$$

In right $\triangle AOB$

$$AB^2 = AO^2 + BO^2 \quad [\because \text{Pythagoras theorem}]$$

$$AB^2 = \left(\frac{1}{2}AC\right)^2 + \left(\frac{1}{2}BD\right)^2 \quad [\because AO = \frac{1}{2}AC, BO = \frac{1}{2}BD]$$

$$AB^2 = \frac{1}{4}AC^2 + \frac{1}{4}BD^2$$

$$4AB^2 = AC^2 + BD^2 \quad [\because \text{Multiplying by 4}]$$

$$\Rightarrow AB^2 + AB^2 + AB^2 + AB^2 = AC^2 + BD^2$$

$$\therefore AB^2 + BC^2 + CD^2 + DA^2 = AC^2 + BD^2 \quad [\because \text{given } AB = BC = CD = AD].$$

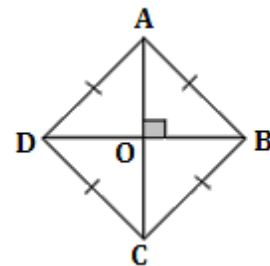

- 30) Two poles of heights 6m and 11m stand on a play ground. If the distance between the feet of the poles is 12 m, find the distance between their tops.
- 31) The perimeter of a right triangle is 20cm and the sides containing the right angle are in the ratio 4 : 3 then find the sides.
- 32) ABC is an isosceles triangle with $AC = BC$. If $AB^2 = 2AC^2$, prove that $\triangle ABC$ is a right triangle.

- 33) In fig. ABC and DBC are two triangles on the same base BC.

If AD intersects BC at O, show that $\frac{ar(\triangle ABC)}{ar(\triangle DBC)} = \frac{AO}{DO}$

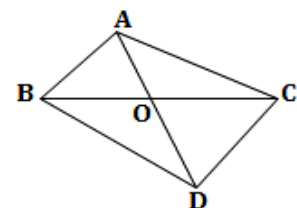

34) In a quadrilateral ABCD the diagonals intersect at O.

If $\frac{AO}{BO} = \frac{CO}{DO}$ then prove that ABCD is a trapezium.

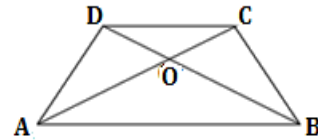

35) In an equilateral triangle, prove that three times the square of one side is equal to four times the square of one of its altitude.

Data : In equilateral triangle ABC,

$AB = BC = AC$ and AD is a perpendicular

height. $\angle ADB = 90^\circ$

To Prove : $3AB^2 = 4AD^2$

Proof : In $\triangle ABD$ and $\triangle ADC$

$\angle D = \angle D = 90^\circ$ [\because given]

$AB = AC$ [\because given]

$AD = AD$ [\because common side]

$\triangle ABD \cong \triangle ADC$ [\because RHS Postulate]

$\therefore BD = CD = \frac{1}{2} BC$ ----->(1)

In right triangle ABD

$AB^2 = AD^2 + BD^2$ [\because Pythagoras theorem]

$AB^2 = AD^2 + \left(\frac{1}{2} BC\right)^2$ [$\because BD = \frac{1}{2} BC$]

$AB^2 = AD^2 + \frac{1}{4} AB^2$ [$\because BC = AB$]

$4 \times AB^2 = 4 \times AD^2 + AB^2$ [\because Multiplying by 4]

$4AB^2 - AB^2 = 4AD^2$

$3AB^2 = 4AD^2$. Hence Proved

36) BL and CM are medians of a triangle ABC

right angled at A. Prove that

$4(BL^2 + CM^2) = 5BC^2$

Solution: in $\triangle ABC$, $\angle A = 90^\circ$

BL and CM are medians of a triangle ABC

From $\triangle ABC$, $BC^2 = AB^2 + AC^2$ ----->(1) (\because Pythagoras theorem)

From $\triangle ABL$, $BL^2 = AL^2 + AB^2$ (\because Pythagoras theorem)

$BL^2 = \left(\frac{AC}{2}\right)^2 + AB^2$ (\because L is the mid-of AC)

$BL^2 = \frac{AC^2}{4} + AB^2$

$4BL^2 = AC^2 + 4AB^2$ ----->(2)

From $\triangle CMA$, $CM^2 = AC^2 + AM^2$ (\because Pythagoras theorem)

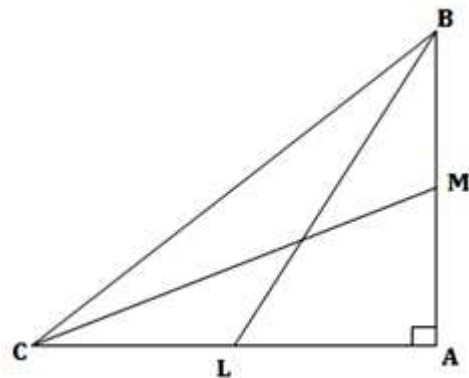
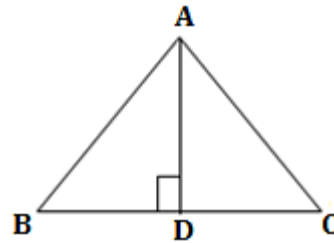

$$CM^2 = AC^2 + \left(\frac{AB}{2}\right)^2 \quad (\because M \text{ is the mid-of } AB)$$

$$CM^2 = AC^2 + \frac{AB^2}{4}$$

$$4CM^2 = 4AC^2 + AB^2 \quad \text{-----}>(3)$$

adding (2) and (3), we have

$$4BL^2 + 4CM^2 = AC^2 + 4AB^2 + 4AC^2 + AB^2$$

$$4(BL^2 + CM^2) = 5(AB^2 + AC^2)$$

$$\therefore 4(BL^2 + CM^2) = 5BC^2 \quad [\because \text{From (1)}]$$

- 37) D and E are the points on the sides CA and CB respectively of a triangle ABC right angled at C. Prove that $AE^2 + BD^2 = AB^2 + DE^2$.

Solution: in $\triangle ABC$, $\angle C = 90^\circ$

D and E are points on the sides CA and CB.

$$\text{From } \triangle ABC, \quad AB^2 = AC^2 + BC^2 \quad \text{-----}>(1) \quad (\because \text{Pythagoras theorem})$$

$$\text{From } \triangle ACE, \quad AE^2 = AC^2 + CE^2 \quad \text{-----}>(2) \quad (\because \text{Pythagoras theorem})$$

$$\text{From } \triangle BCD, \quad BD^2 = DC^2 + BC^2 \quad \text{-----}>(3) \quad (\because \text{Pythagoras theorem})$$

$$\text{From } \triangle DCE, \quad DE^2 = DC^2 + CE^2 \quad \text{-----}>(4) \quad (\because \text{Pythagoras theorem})$$

$$AE^2 + BD^2 = AC^2 + CE^2 + DC^2 + BC^2 \quad [\because \text{adding (2) and (3)}]$$

$$AE^2 + BD^2 = (AC^2 + BC^2) + (CE^2 + DC^2)$$

$$\therefore AE^2 + BD^2 = AB^2 + DE^2 \quad [\because \text{From (1) and (4)}]$$

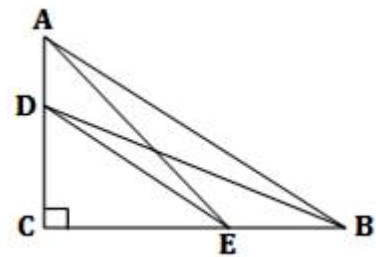

- 38) A ladder reaches a window which is 12 m above the ground on one side of the street. Keeping its foot at the same point, the ladder is turned to the other side of the street to reach another window 9 m high. Find the width of the street if the length of the ladder is 15 m.

Solution: According to data $AB = 12\text{m}$, $CD = 9\text{m}$

Length of the ladder $BE = DE = 15\text{m}$.

$$\text{From } \triangle ABE, \quad BE^2 = AB^2 + AE^2 \quad (\because \text{Pythagoras theorem})$$

$$15^2 = 12^2 + AE^2$$

$$225 - 144 = AE^2$$

$$AE^2 = 81$$

$$AE = 9$$

$$\therefore AE = 9\text{m} \quad \text{-----}>(1)$$

$$\text{From } \triangle CDE, \quad DE^2 = CD^2 + EC^2 \quad (\because \text{Pythagoras theorem})$$

$$15^2 = 9^2 + EC^2$$

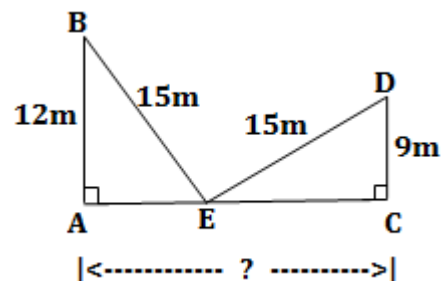

$$225 - 81 = EC^2$$

$$EC^2 = 144$$

$$EC = 12^2$$

$$\therefore EC = 12\text{m} \text{ -----}>(2)$$

$$AC = AE + EC = 9 + 12 = 21\text{m} \quad [\because \text{From (1) and (2)}]$$

\therefore the width of the street is 21 m.

4 or 5 Marks Questions (LA-2/ LA-3)

39) State and prove Thales theorem (Basic Proportionality Theorem) .

If a line is drawn parallel to one side of a triangle to intersect the other two sides in distinct points , the other two sides are divided in the same ratio.

Data : In $\triangle ABC$ $DE \parallel BC$.

To Prove : $\frac{AD}{DB} = \frac{AE}{EC}$

Construction : Draw $DM \perp AC$ and $EN \perp AB$. Join BE and CD .

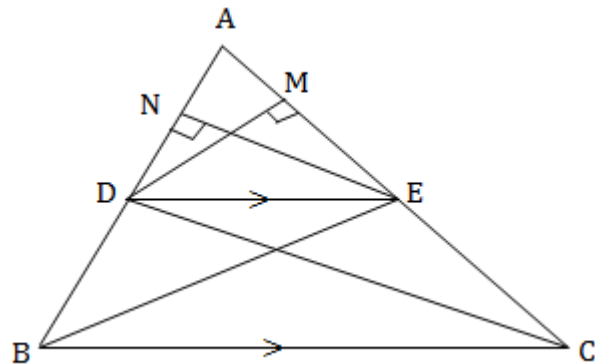

Proof :

$$\frac{\text{ar}(\triangle ADE)}{\text{ar}(\triangle BDE)} = \frac{\frac{1}{2} \times AD \times EN}{\frac{1}{2} \times DB \times EN} \quad (\because \text{Area of } \triangle = \frac{1}{2} \times \text{base} \times \text{height})$$

$$\frac{\text{ar}(\triangle ADE)}{\text{ar}(\triangle BDE)} = \frac{AD}{DB} \quad \text{-----}> (1)$$

$$\frac{\text{ar}(\triangle ADE)}{\text{ar}(\triangle CED)} = \frac{\frac{1}{2} \times AE \times DM}{\frac{1}{2} \times EC \times DM} \quad (\because \text{Area of } \triangle = \frac{1}{2} \times \text{base} \times \text{height})$$

$$\frac{\text{ar}(\triangle ADE)}{\text{ar}(\triangle CED)} = \frac{AE}{EC} \quad \text{-----}> (2)$$

But $\triangle BDE$ and $\triangle CED$ are standing on the same base DE and between $DE \parallel BC$.

$$\text{ar}(\triangle BDE) = \text{ar}(\triangle CED) \quad \text{-----}> (3)$$

\therefore from equations (1), (2) and (3)

$$\frac{AD}{DB} = \frac{AE}{EC}$$

Hence the proof.

40) AAA Similarity Criterion :

If in two triangles, corresponding angles are equal, then their corresponding sides are in the same ratio (or proportional). Hence prove that the two triangles are similar.

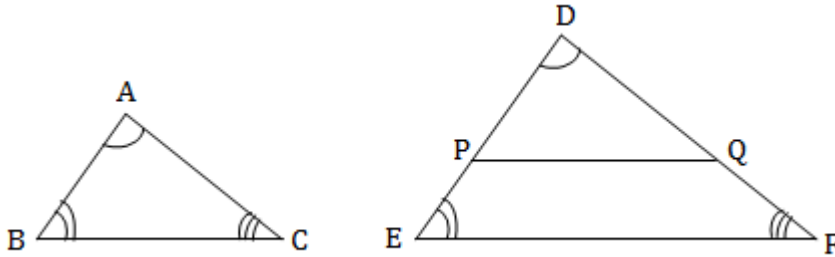

Data : In $\triangle ABC$ and $\triangle DEF$

$$\angle A = \angle D$$

$$\angle B = \angle E$$

$$\angle C = \angle F$$

To Prove : $\frac{AB}{DE} = \frac{BC}{EF} = \frac{AC}{DF}$

Construction : Mark points P and Q on DE and DF such that DP = AB and DQ = AC. Join PQ.

Proof : In $\triangle ABC$ and $\triangle DPQ$

$$\angle A = \angle D \quad (\because \text{Data})$$

$$AB = DP \quad (\because \text{Construction})$$

$$AC = DQ \quad (\because \text{Construction})$$

$$\triangle ABC \cong \triangle DPQ \quad (\because \text{SAS Postulate})$$

$$\therefore BC = PQ \quad \text{-----} > (1) \quad (\because \text{CPCT})$$

$$\angle B = \angle P \quad \left. \vphantom{\angle B = \angle P} \right\} (\because \text{CPCT})$$

$$\angle B = \angle E \quad \left. \vphantom{\angle B = \angle E} \right\} (\because \text{Data})$$

$$\therefore \angle P = \angle E \quad (\because \text{Axiom - 1})$$

$$\Rightarrow PQ \parallel EF$$

$$\frac{DP}{DE} = \frac{PQ}{EF} = \frac{DQ}{DF} \quad (\because \text{Corollary of Thales theorem})$$

$$\frac{AB}{DE} = \frac{BC}{EF} = \frac{AC}{DF} \quad [\because \text{from eq. (1) and construction}]$$

Hence the proof.

41) **Areas of Similar Triangles:**

The ratio of the areas of two similar triangles is equal to the square of the ratio of their corresponding sides .

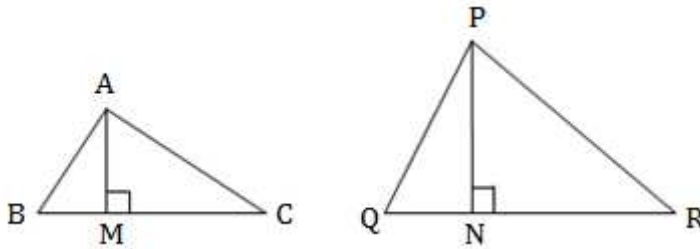

Data : $\Delta ABC \sim \Delta PQR$

$$\Rightarrow \frac{AB}{PQ} = \frac{BC}{QR} = \frac{AC}{PR}$$

To Prove : $\frac{ar(\Delta ABC)}{ar(\Delta PQR)} = \left(\frac{AB}{PQ}\right)^2 = \left(\frac{BC}{QR}\right)^2 = \left(\frac{AC}{PR}\right)^2$

Construction : Draw $AM \perp BC$ and $PN \perp QR$.

Proof : $\frac{ar(\Delta ABC)}{ar(\Delta PQR)} = \frac{\frac{1}{2} \times BC \times AM}{\frac{1}{2} \times QR \times PN}$ (\because Area of $\Delta = \frac{1}{2} \times$ base \times height)

$$\frac{ar(\Delta ABC)}{ar(\Delta PQR)} = \frac{BC \times AM}{QR \times PN} \text{ -----} > (1)$$

In ΔABM and ΔPQN

$\angle B = \angle Q$ ($\because \Delta ABC \sim \Delta PQR$)

$\angle M = \angle N = 90^\circ$ (\because Construction)

$\therefore \Delta ABM \sim \Delta PQN$ (\because AA Similarity criterion)

$\therefore \frac{AM}{PN} = \frac{AB}{PQ}$ ----- > (2)

But $\frac{AB}{PQ} = \frac{BC}{QR} = \frac{AC}{PR}$ ----- > (3) (\because Data)

$\frac{ar(\Delta ABC)}{ar(\Delta PQR)} = \frac{AB}{PQ} \times \frac{AB}{PQ}$ (\because substituting eqs.(2) and (3) in (1))

$$\frac{ar(\Delta ABC)}{ar(\Delta PQR)} = \left(\frac{AB}{PQ}\right)^2$$

Now from eq.(3)

$$\frac{ar(\Delta ABC)}{ar(\Delta PQR)} = \left(\frac{AB}{PQ}\right)^2 = \left(\frac{BC}{QR}\right)^2 = \left(\frac{AC}{PR}\right)^2$$

Hence the proof.

42) State and Prove Pythagoras Theorem .

“ In a right angled triangle , the square on the hypotenuse is equal to the sum of the squares on other two sides ” .

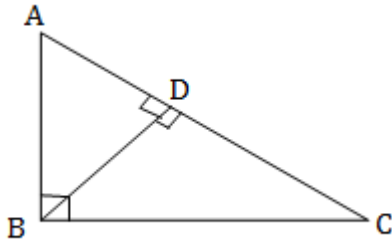

Data : $\triangle ABC$ is a right triangle and $\angle B = 90^\circ$

To Prove : $AC^2 = AB^2 + BC^2$

Construction : Draw $BD \perp AC$

Proof : In $\triangle ADB$ and $\triangle ABC$

$$\angle D = \angle B = 90^\circ \quad (\because \text{Data and Construction})$$

$$\angle A = \angle A \quad (\because \text{Common angle})$$

$$\triangle ADB \sim \triangle ABC \quad (\because \text{AAA Similarity Criterion})$$

$$\therefore \frac{AD}{AB} = \frac{AB}{AC} \quad (\because \text{Proportional sides})$$

$$AC \cdot AD = AB^2 \text{ -----} > (1)$$

Similarly

In $\triangle BDC$ and $\triangle ABC$

$$\angle D = \angle B = 90^\circ \quad (\because \text{Data and Construction})$$

$$\angle C = \angle C \quad (\because \text{Common angle})$$

$$\triangle BDC \sim \triangle ABC \quad (\because \text{AAA Similarity Criterion})$$

$$\therefore \frac{DC}{BC} = \frac{BC}{AC} \quad (\because \text{Proportional sides})$$

$$AC \cdot DC = BC^2 \text{ -----} > (2)$$

$$AC \cdot AD + AC \cdot DC = AB^2 + BC^2 \quad [\because \text{By adding (1) and (2)}]$$

$$AC (AD + DC) = AB^2 + BC^2$$

$$AC \times AC = AB^2 + BC^2 \quad (\because \text{from fig. } AD + DC = AC)$$

$$AC^2 = AB^2 + BC^2$$

Hence the proof.

43) State and Prove the converse of Pythagoras Theorem .

“ In a triangle, if square of one side is equal to the sum of the squares of the other two sides, then the angle opposite to the first side is a right angle ” .

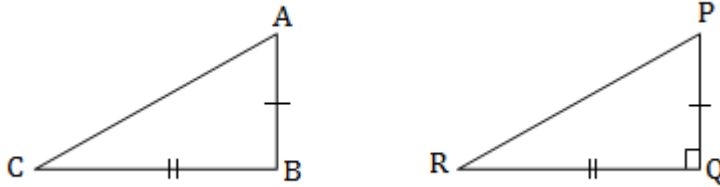

Data : In ΔABC , $AC^2 = AB^2 + BC^2$

To Prove : $\angle B = 90^\circ$

Construction : construct another ΔPQR right angled at Q such that $PQ = AB$ and $QR = BC$

Proof : In ΔPQR

$$PR^2 = PQ^2 + QR^2 \quad (\because \angle Q = 90^\circ, \text{Pythagoras theorem})$$

$$PR^2 = AB^2 + BC^2 \text{ -----}>(1) \quad (\because \text{By Construction})$$

$$AC^2 = AB^2 + BC^2 \text{ -----}>(2) \quad (\because \text{Data})$$

$$\therefore AC = PR \quad \text{-----}>(3) \quad [\because \text{From (1) and (2)}]$$

In ΔABC and ΔPQR

$$AB = PQ \quad (\because \text{By Construction})$$

$$BC = QR \quad (\because \text{By Construction})$$

$$AC = PR \quad [\because \text{From (3)}]$$

$$\therefore \Delta ABC \cong \Delta PQR \quad (\because \text{SSS congruence})$$

$$\therefore \angle B = \angle Q \quad (\because \text{CPCT})$$

$$\text{But, } \angle Q = 90^\circ \quad (\because \text{By Construction})$$

$$\therefore \angle B = 90^\circ$$

Hence the proof.

UNIT – 3 : PAIR OF LINEAR EQUATIONS IN TWO VARIABLES

1 Mark Questions (MCQ)

- 1) If the pair of linear equations $a_1x + b_1y + c_1 = 0$ and $a_2x + b_2y + c_2 = 0$ has infinitely many solutions then which of the following condition is correct

A) $\frac{a_1}{a_2} = \frac{b_1}{b_2} = \frac{c_1}{c_2}$	B) $\frac{a_1}{a_2} = \frac{b_1}{b_2} \neq \frac{c_1}{c_2}$
C) $\frac{a_1}{a_2} = \frac{b_1}{b_2}$	D) $\frac{a_1}{a_2} \neq \frac{b_1}{b_2} \neq \frac{c_1}{c_2}$

- 2) If the lines representing the equations $a_1x + b_1y + c_1 = 0$ and $a_2x + b_2y + c_2 = 0$ intersect at one point, then which of the following condition is correct

A) $\frac{a_1}{a_2} = \frac{b_1}{b_2}$	B) $\frac{a_1}{a_2} = \frac{b_1}{b_2} = \frac{c_1}{c_2}$
C) $\frac{a_1}{a_2} \neq \frac{b_1}{b_2}$	D) $\frac{b_1}{b_2} \neq \frac{c_1}{c_2}$

- 3) The straight lines representing the equations $x - 2y = 0$ and $3x + 4y - 20 = 0$ are

A) Parallel	B) Intersect	C) Coincide	D) Does not intersect
-------------	--------------	-------------	-----------------------

- 4) Pair of the equations $2x + 3y - 9 = 0$ and $4x + 6y - 18 = 0$ has

A) No solution	B) Unique solution.
C) Only two solutions	D) Infinitely many solutions

- 5) The solutions of equations $x + 3y = 6$ and $2x - 3y = 12$ are

A) $x = 0, y = 6$	B) $x = 6, y = -6$
C) $x = 6, y = 0$	D) $x = 0, y = 0$

- 6) If the equations $2x + y = 3$ and $y = mx + 3$ represent the same straight line then the value of m is

A) -3	B) -2	C) 2	D) 3
-------	-------	------	------

- 7) If $x = -y$ and $y > 0$, then which of the following statement is not correct?

A) $x^2y > 0$	B) $x + y = 0$	C) $xy < 0$	D) $\frac{1}{x} - \frac{1}{y} = 0$
---------------	----------------	-------------	------------------------------------

- 8) If the equations $x + 5y = 7$ and $4x + 20y = -k$ represent coinciding straight lines then the value of k is

A) -28	B) 24	C) 28	D) -24
--------	-------	-------	--------

- 9) The equations $x + 2y - 4 = 0$ and $2x + 4y - 12 = 0$ represent parallel lines. So the equations has

A) No solution	B) Unique solution
C) Only two solutions	D) Infinitely many solutions

- 10) The intersecting point of the graphs of the equations $y = 2x - 2$ and $y = 4x - 4$ is
 A) (1, 0) B) (-1, 0) C) (0, 1) D) (0, -1)

1 Mark Questions (VSA)

- 11) Write the coordinates of the origin.
 12) Write the general form of a linear equation in one variable.
 13) Write the general form of a pair of linear equations in two variables.

	1) A	2) C	3) B	4) D	5) C	6) B	7) D
Ans	8) A	9) A	10) A	11) (0, 0)			
	12) $ax + b = 0$ (Here $a \neq 0$ and a, b are real numbers)						
	13) $a_1x + b_1y + c_1 = 0$ } Here a_1, b_1, c_1 & a_2, b_2, c_2 are real numbers $a_2x + b_2y + c_2 = 0$ } and $a_1^2 + b_1^2 \neq 0, a_2^2 + b_2^2 \neq 0$						

2 Marks Questions (SA)

- 14) Solve the given pair of linear equations .

$$x + y = 14$$

$$x - y = 4$$

Solution :

$$x + y = 14 \longrightarrow (1)$$

$$x - y = 4 \longrightarrow (2)$$

$$\begin{array}{r} 2x = 18 \\ \hline x = \frac{18}{2} \end{array} \quad [\because \text{Adding eq.(1) and eq.(2)}]$$

$$\therefore x = 9$$

Substituting the value of x in eq. (1)

$$9 + y = 14$$

$$y = 14 - 9$$

$$\therefore y = 5$$

Solution is $x = 9$ and $y = 5$

Alternate method:

Write the given equations in standard form and compare

$$x + y - 14 = 0 \longrightarrow (1) \quad \therefore a_1 = 1, \quad b_1 = 1, \quad c_1 = -14,$$

$$x - y - 4 = 0 \longrightarrow (2) \quad \therefore a_2 = 1, \quad b_2 = -1, \quad c_2 = -4$$

By using cross multiplication formula	
$x = \frac{b_1c_2 - b_2c_1}{a_1b_2 - a_2b_1}$	$y = \frac{c_1a_2 - c_2a_1}{a_1b_2 - a_2b_1}$
$x = \frac{1(-4) - (-1)(-14)}{1(-1) - 1(1)}$	$y = \frac{(-14)1 - (-4)1}{1(-1) - 1(1)}$
$x = \frac{-4 - 14}{-1 - 1}$	$y = \frac{-14 + 4}{-1 - 1}$
$x = \frac{-18}{-2}$	$y = \frac{-10}{-2}$
$\therefore x = 9$	$\therefore y = 5$

15) Solve the following pairs of linear equations .

(i) $2x + 3y = 11$ (ii) $x - y = 26$ (iii) $x + y = 180$

$2x - 4y = -24$ $x - 3y = 0$ $x - y = 18$

16) **The difference between two numbers is 26 and one number is three times the other Find them .**

Solution : Let the two numbers be x and y .

Given $x - y = 26$ \longrightarrow (1)

and $x = 3y$ \longrightarrow (2)

Substitute eq. (2) in eq.(1)

$$3y - y = 26$$

$$2y = 26$$

$$y = \frac{26}{2}$$

$$y = 13$$

Substituting the value of y in eq. (2)

$$x = 3(13)$$

$$x = 39$$

\therefore The numbers are 39 and 13 .

17) The larger of two supplementary angles exceeds the smaller by 18 degrees. Find them.

18) The coach of a cricket team buys 7 bats and 6 balls for Rs 3800. Later she buys 3 bats and 5 balls for Rs 1750. Find the cost of each bat and each ball.

19) A fraction becomes $\frac{9}{11}$, if 2 is added to both the numerator and the denominator.

If 3 is added to both the numerator and the denominator it becomes $\frac{5}{6}$. Find the fraction.

- 20) Five years hence, the age of Jacob will be three times that of his son . Five years ago, Jacob's age was seven times that of his son. What are their present ages?
- 21) Five years ago, Nuri was thrice as old as Sonu. Ten years later, Nuri will be twice as old as Sonu . How old are Nuri and Sonu?
- 22) Find the value of k for which the system of equations has infinitely many solutions.

$$2x - 3y = 7$$

$$(k + 1)x + (1 - 2k)y = (5k - 4)$$

Solution: The given equations in standard form

$$2x - 3y - 7 = 0$$

$$\text{here } a_1 = 2, \quad b_1 = -3, \quad c_1 = -7,$$

$$(k + 1)x + (1 - 2k)y + (4 - 5k) = 0 \quad \text{here } a_2 = k + 1, \quad b_2 = 1 - 2k, \quad c_2 = 4 - 5k$$

The equations has infinitely many solutions, so $\frac{a_1}{a_2} = \frac{b_1}{b_2} = \frac{c_1}{c_2}$

$$\frac{2}{k + 1} = \frac{-3}{1 - 2k} = \frac{-7}{4 - 5k}$$

$$\frac{2}{k+1} = \frac{-3}{1-2k}$$

$$\text{and } \frac{-3}{1-2k} = \frac{-7}{4-5k}$$

$$2 - 4k = -3k - 3$$

$$\text{and } -12 + 15k = -7 + 14k$$

$$2 + 3 = 4k - 3k$$

$$\text{and } 15k - 14k = 12 - 7$$

$$k = 5$$

$$\text{and } k = 5$$

- 23) Find the value of k for which the system of equations has infinitely many solutions.

$$kx + 3y - (k - 3) = 0$$

$$12x + ky - k = 0$$

4 Marks Questions (LA-2)

- 24) Solve the given linear equation graphically .

$$x - 2y = 0$$

$$3x + 4y = 20$$

Solution :

$$x - 2y = 0$$

$$3x + 4y = 20$$

x	0	2	4
$y = \frac{x}{2}$	0	1	2

x	0	4	-4
$y = \frac{20 - 3x}{4}$	5	2	8

Scale : X - axis : 1cm = 1 unit and Y - axis : 1cm = 1 unit

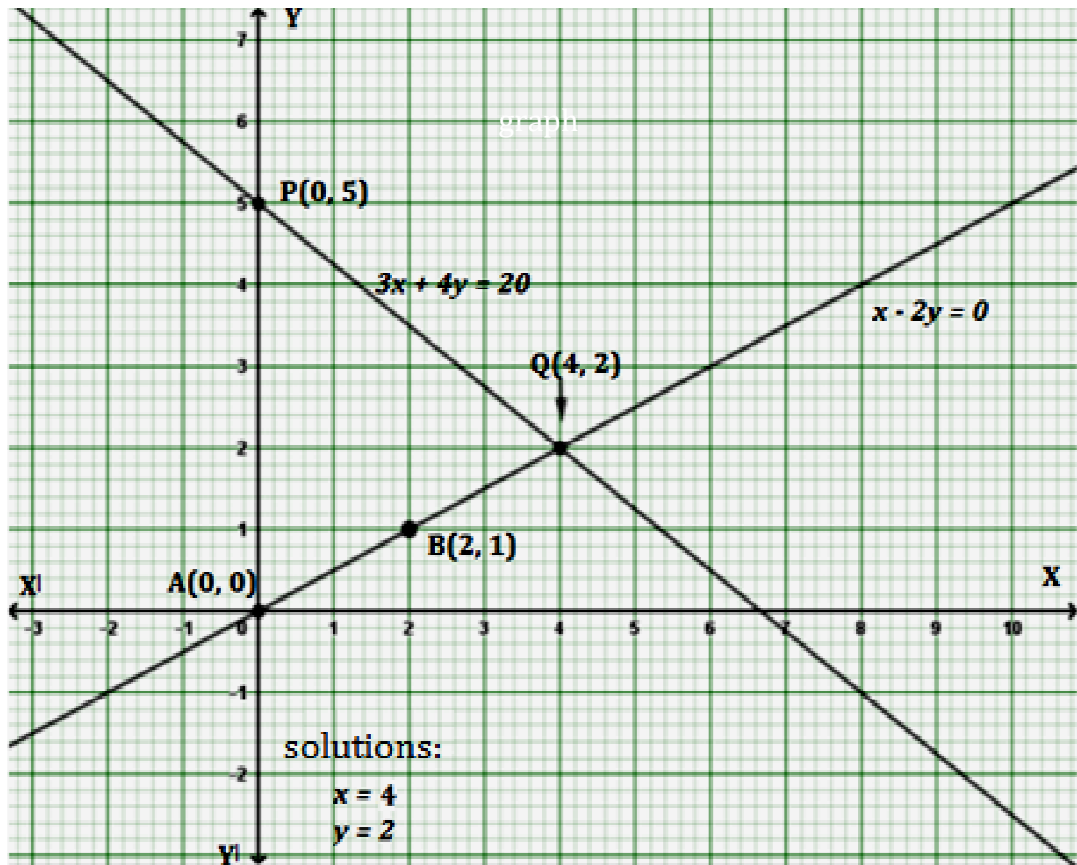

25) Solve the following linear equations graphically.

(i) $2x - y = 2$

$4x - y = 4$

(ii) $x + 3y = 6$

$2x - 3y = 12$

(iii) $x + y = 5$

$2x - y = 4$

(iv) $2x + y - 6 = 0$

$2x - y - 2 = 0$

(v) $x = y - 6$

$y = 2 - x$

(vi) $x + 2y = 0$

$2x + y + 6 = 0$

(vii) $2x + y = -7$

$x - y = 1$

(viii) $x - 2y = 2$

$2x - y = -2$

(ix) $x - 2y = 0$

$x + 2y = -8$

(x) $3x + 2y = 0$

$2x - y = 7$

(xi) $2x + 3y = -2$

$3x - y = 8$

(xii) $x - y = 4$

$2x + y = 5$

5 Marks Questions (LA-3)

26) Draw the graphs of the equations $x - y + 1 = 0$ and $3x + 2y - 12 = 0$. Determine the coordinates of the vertices of the triangle formed by these lines and the x - axis and shade the triangular region.

Solution: $x - y + 1 = 0$

$3x + 2y - 12 = 0$

x	0	2	3
$y = x + 1$	1	3	4

x	0	2	4
$y = \frac{12 - 3x}{2}$	6	3	0

Scale : X - axis : 1cm = 1 unit and Y - axis : 1cm = 1 unit

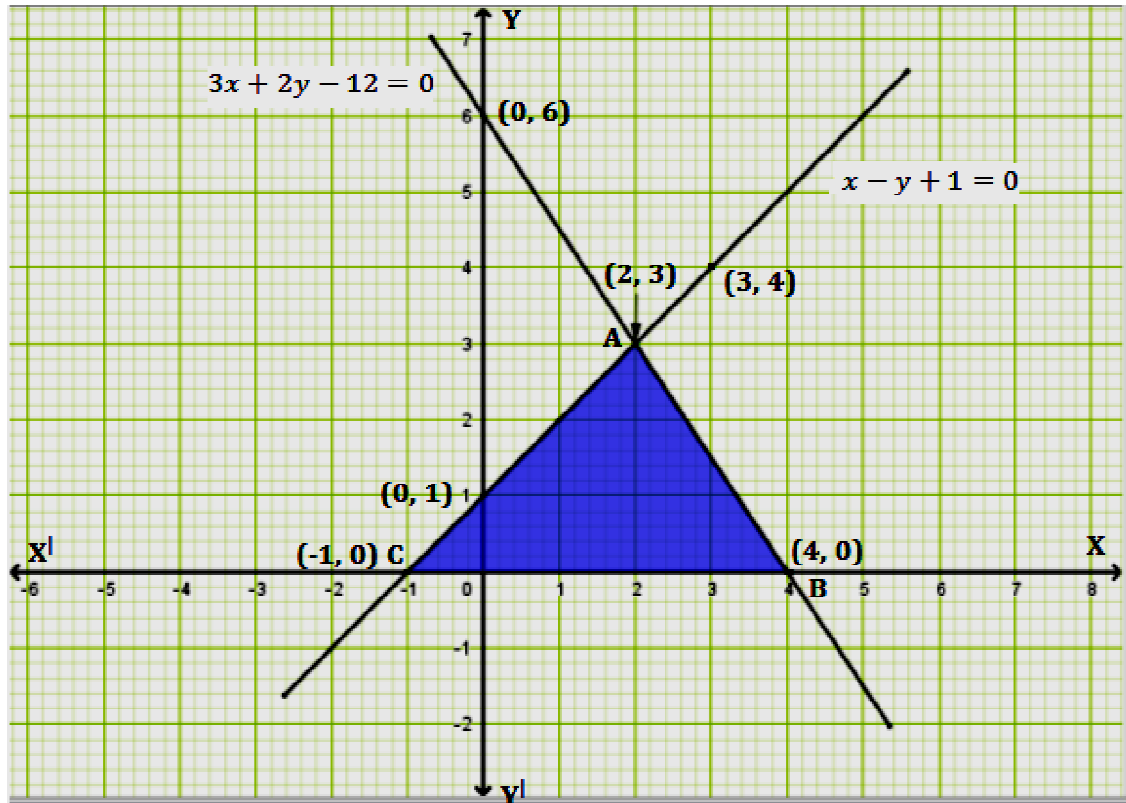

UNIT - 4: CIRCLES

1 Mark Questions (MCQ)

- 1) If the two end points of chord coincide, then it is called
 - A) Secant
 - B) Tangent
 - C) line Segment
 - D) diameter
- 2) Number of tangent drawn at a point on a circle is
 - A) 2
 - B) 1
 - C) Infinite
 - D) 3
- 3) The straight line which intersects the circle at only one point is
 - A) Radius
 - B) tangent
 - C) Secant
 - D) line segment
- 4) A straight line which passes through any two distinct points of a circle
 - A) Tangent
 - B) diameter
 - C) secant
 - D) line segment

5) Maximum number of tangents drawn to a circle from an external point is

- A) 1 B) 3 C) 2 D) infinite

6) In the adjoining figure $OX \perp PQ$, $OX = 3\text{cm}$ and $OP = 5\text{cm}$ then the length of the chord PQ is

- A) 5 cm B) 4 cm C) 8 cm D) 10 cm

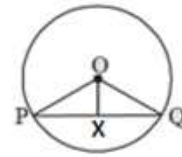

7) In the adjoining figure if $\angle AOP = 60^\circ$ then $\angle APO =$

- A) 120° B) 90° C) 60° D) 30°

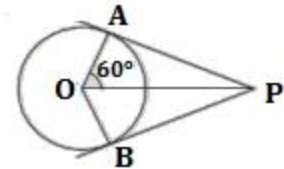

8) In the figure PQ and RS is chord which are equidistant from the centre O . If $PQ = 6\text{cm}$ then $RS =$

- A) 5 cm B) 6 cm C) 8 cm D) 3 cm

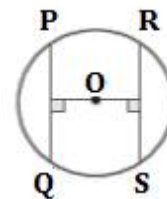

9) Tangents PQ and PR are drawn to a circle as shown in figure. if $\angle APO = 90^\circ$ and $PQ = 8\text{cm}$ then radius of circle is

- A) 5 cm B) 6 cm C) 8 cm D) 3 cm

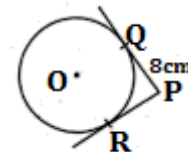

10) In the figure if PA and PB are tangents to a circle with centre O . If $\angle APB = 40^\circ$ then, $\angle AOB$ is,

- A) 90° B) 50° C) 140° D) 150°

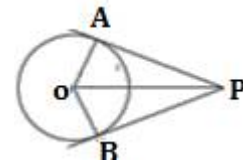

11) In the figure if BC is the diameter, the value of X is

- A) 90° B) 50° C) 180° D) 160°

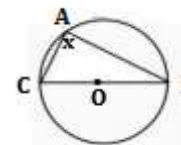

12) The length of the tangent from an external point at a distance of 5cm from the centre of the circle of radius 3cm is

- A) 4 cm B) 3.5 cm C) 4.5 cm D) 5.5 cm

13) The length of the tangent is 24 cm which is drawn to a circle of centre O at a distance 25 cm from its centre, then its radius is

- A) 7 cm B) 12 cm C) 15 cm D) 24.5 cm

- 14) In the given figure radius $OA = 10\text{ cm}$ and $\angle ACB = 45^\circ$.
The length of Chord AB is

A) 10 cm B) $10\sqrt{2}\text{ cm}$ C) 9 cm D) $10\sqrt{3}\text{ cm}$

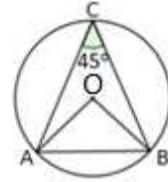

- 15) Two parallel tangents are drawn to a circle. The distance between these two parallel tangents is 18 cm . Then the length of radius is
A) 8 cm B) 10 cm C) 9 cm D) 7.5 cm

- 16) In the given figure, the sides of $\triangle ABC$ are tangents to the circle with centre 'O'. If $BZ = 4\text{ cm}$, $AZ = 3\text{ cm}$ and $AC = 9\text{ cm}$, then the length of the side BC is

A) 7 cm B) 8 cm C) 9 cm D) 10 cm

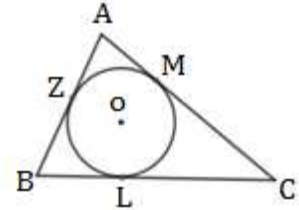

1 Mark Questions (VSA)

- 17) In the figure if $\angle POQ = 130^\circ$ TP and TQ are tangents to a circle of centre 'o' then what is the measure of $\angle PTQ$?

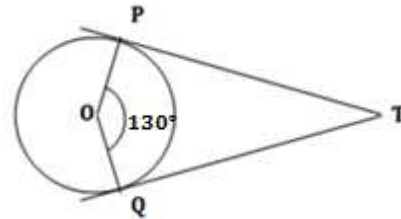

- 18) PA, PC and CD are tangents to a circle a circle with centre 'O'. If $PA = 3\text{ cm}$ and $CD = 5\text{ cm}$ then find the length of PC .

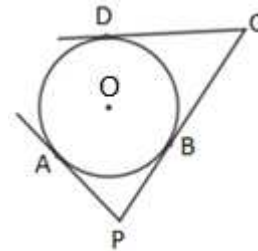

- 19) Define congruent circles.
20) Define concentric circles.
21) In a circle, what is the measure of the angle between the tangent and the radius at the point of contact?

ಉತ್ತರ	1) B	2) B	3) B	4) C	5) C	6) C	7) D	8) B	9) C	10) C
	11) A	12) A	13) A	14) B	15) C	16) D	17) 50°	18) 8 cm		
19) Circles which are having same radii and different centres are called congruent circles.										
20) Circles which are having same centre and different radii are called concentric circles.								21) 90°		

2 Marks Questions (SA)

- 22) Answer the following in the given figure.
(i) Tangent
(ii) Secant
(iii) Radius
(iv) Chord
(v) Point of contact.

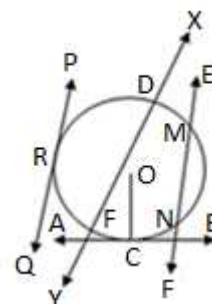

- 23) In the adjoining figure quadrilateral ABCD is inscribed in a circle.
Show that $AB + CD = AD + BC$.

Solution:- In fig $AP = AS$ ----> (1) (Theorem)

$BP = BQ$ ----> (2) (Theorem)

$CQ = CR$ ----> (3) (Theorem)

$DR = DS$ ----> (4) (Theorem)

LHS = $AB + CD$

= $(AP + BP) + (DR + CR)$ (from fig)

= $(AS + BQ) + (DS + CQ)$

= $(AS + DS) + (BQ + CQ)$

= $AD + BC = \text{RHS}$

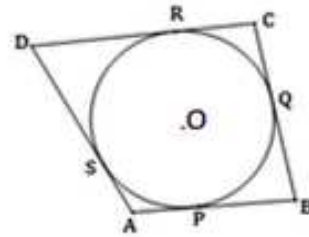

3Marks Questions (LA-1)

- 24) Theorem:- "The tangent at any point of a circle is perpendicular to the radius through the point of contact". Prove this.

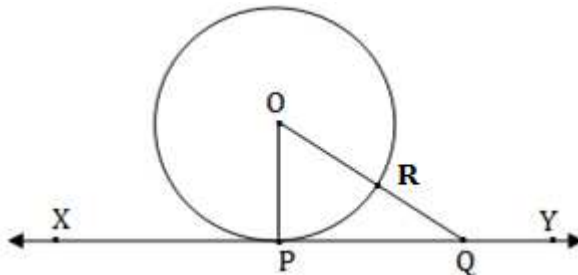

Data: A circle with centre O and XY is a tangent to the circle at point P.
OP is the radius through the Point P.

To prove: $OP \perp XY$

Construction: Take a point Q other than P on XY and join OQ.
Let OQ intersect the circle at R.

Proof: $OQ > OR$ (\because from the figure)

But $OP = OR$ (\because radii of the same circle)

$\therefore OQ > \text{radius } OP$

Since this happens for every point on the line XY except the point P.

$\therefore OP$ is the shortest distance between the point O and tangent XY.

$\therefore OP \perp XY$

\therefore Hence the proof.

- 25) **Theorem :-** “The tangents drawn to a circle from an external point are equal”
 prove this.

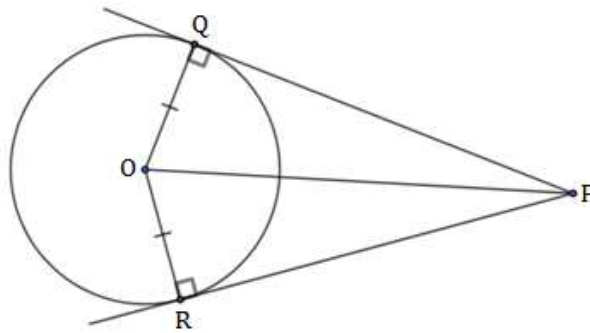

Data: A circle with centre O and P is an external point.
 PQ and PR are the tangents drawn from an external point P.

To prove: $PQ = PR$

Construction: Join OP, OQ and OR.

Proof: In ΔOQP and ΔORP

$OQ = OR$ (\because Radii of same circle)

$OP = OP$ (\because Common side)

$\angle Q = \angle R = 90^\circ$ (\because tangent \perp radius)

$\Delta OQP \cong \Delta ORP$ (\because RHS criteria)

$PQ = PR$ (\because CSCT)

\therefore Hence the proof.

- 26) In the figure, to a circle with centre ‘O’, TP and TQ are the tangents drawn from T, show that $\angle PTQ = 2\angle OPQ$

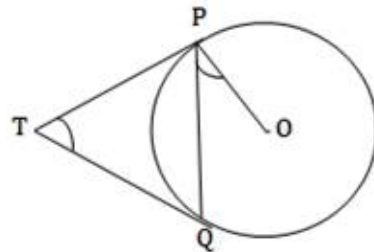

- 27) 3cm and 5cm are the radii of two concentric circles with centre ‘O’. Find the length of the chord which touches the smaller circle.

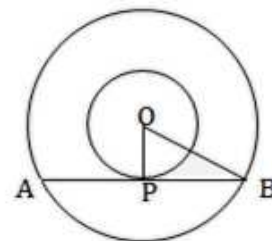

- 28) PA and PB are the tangents to a circle with centre ‘O’ drawn from an external point P if $\angle APB = 120^\circ$ then show that $OP = 2AP$.

(Hint: In ΔOAP , $\cos 60^\circ = \frac{AP}{OP}$)

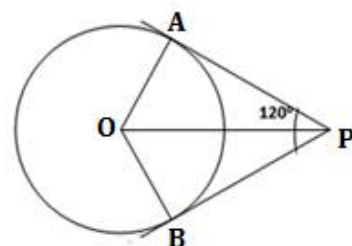

- 29) In the figure 'O' is the Centre of the circle and T is an external point, TP and TQ are tangents from T show that $\angle PTQ + \angle POQ = 180^\circ$

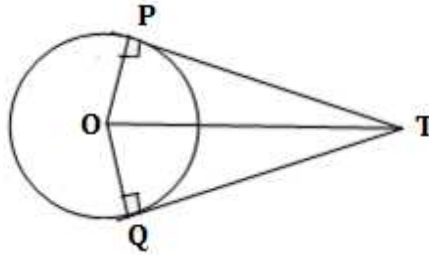

UNIT- 5: AREA RELATED TO CIRCLES

1 Mark Questions (MCQ)

- The region bounded by two radii and corresponding arc of a circle is
 A) Segment B) Sector C) Area D) Perimeter
- The region bounded by chord and corresponding arc of a circle is
 A) Perimeter B) Sector C) Area D) Segment
- Area of sector with sector angle x and radius of circle P is
 A) $\frac{\pi px^2}{360}$ B) $\frac{\pi px^2}{270}$ C) $\frac{\pi xp^2}{270}$ D) $\frac{\pi xp^2}{360}$
- Angle of the sector is 90° then the ratio of Area of circle to area of sector is
 A) 1:4 B) 1:2 C) 4:1 D) 2:3
- Area of square inscribed in a circle of unit radius is
 A) $\frac{\pi}{2}$ Sq. units B) π Sq. units
 C) $\sqrt{2}$ Sq. units D) 2 Sq. units
- Length of an arc of a sector of angle θ is,
 A) $\frac{\theta}{360} \times \pi r$ Units B) $\frac{\theta}{360} \times 2\pi r$ Units
 C) $\frac{\theta}{360} \times 2\pi$ Units D) $\frac{\theta}{360} \times \pi$ Units
- If the perimeter and the area of a circle are numerically equal, then the radius of the circle is,
 A) 2 Units B) π Units C) 4 Units D) 7 Units

1 Mark Questions (VSA)

- 8) In the figure, If θ is the sector angle and r is the radius of the sector. The length of arc AXB is,

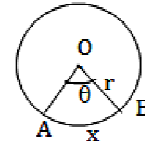

- 9) What is the area of the sector of circle with radius r which makes an angle 360° ?
- 10) If the angle formed at the centre of a circle with radius r is 1° . What is the area of sector?
- 11) If the angle formed at the centre of a circle with radius r is 90° , what is the area of the sector?
- 12) Area of circle is 154cm^2 , and Area of minor sector is 7.7cm^2 , then calculate area of major sector of circle.

- 13) In the figure, area of two concentric circles is 154 cm^2 and 1386 cm^2 respectively. Find the area of shaded portion?



- 14) The radii of two concentric circle are 7cm and 14cm. What is the ratio of their circumference?
- 15) The radii of two concentric circle are 7cm and 14cm. What is the ratio of their areas?
- 16) The circumference of two concentric circles are 28π and 42π respectively. What is the numerical sum of their radii?
- 17) If the angle formed at the centre of a circle with radius r is θ . What is the perimeter of the sector?
- 18) The circumference of a circle is 44cm. Find the circumference of a quadrant of the circle.

Ans	1) B	2) D	3) D	4) C	5) D
6) B	7) A	8) $\frac{\theta}{360} \times 2\pi r$ Units		9) πr^2	10) $\frac{\pi r^2}{360}$
11) $\frac{\pi r^2}{4}$	12) 146.3cm^2	13) 1232cm^2	14) 1:2	15) 1:4	16) 35
17) $\left(\frac{\theta}{360} \times 2\pi r + 2r\right)$ Units			18) 11cm		

2 Marks Questions (SA)

(Unless stated take $\pi = \frac{22}{7}$)

- 19) The radii of two circles are 19 cm and 9 cm respectively. Find the radius of the circle which has circumference equal to the sum of the circumferences of the two circles.

Solution:- Radii $r_1 = 19\text{ cm}$ and $r_2 = 9\text{ cm}$

$$2\pi R = 2\pi r_1 + 2\pi r_2$$

$$2\pi R = 2\pi(r_1 + r_2)$$

$$R = (r_1 + r_2)$$

$$R = 19 + 9$$

$$R = 28 \text{ cm}$$

- 20) The radii of two circles are 8 cm and 6 cm respectively. Find the radius of the circle having area equal to the sum of the areas of the two circles.

Solution:- Radius $r_1 = 8 \text{ cm}$ and $r_2 = 6 \text{ cm}$

$$\pi R^2 = \pi r_1^2 + \pi r_2^2$$

$$\pi R^2 = \pi(r_1^2 + r_2^2)$$

$$R^2 = (r_1^2 + r_2^2)$$

$$R^2 = (8^2 + 6^2)$$

$$R^2 = (8^2 + 6^2)$$

$$R^2 = 64 + 36 = 100$$

$$R^2 = 10^2$$

$$R = 10 \text{ cm}$$

- 21) Find the area of a sector of a circle with radius 4cm if angle of the sector is 30°

Solution:- Radius $r = 4 \text{ cm}$

Angle of the sector $\theta = 30^\circ$

$$\text{Area of the sector} = \frac{\theta}{360} \times \pi r^2$$

$$= \frac{30^\circ}{360} \times \frac{22}{7} \times 4^2$$

$$= \frac{1}{12} \times \frac{22}{7} \times 16$$

$$= \frac{1}{3} \times \frac{22}{7} \times 4$$

$$= \frac{88}{21}$$

$$= 4.19 \text{ cm}^2$$

- 22) If radius is 4 cm and angle of sector is 30° , find the area of corresponding major sector.

- 23) Find the area of a sector of a circle with radius 6cm and if angle of the sector is 60° .

- 24) Find the area of a quadrant of a circle whose circumference is 22cm.

- 25) In a circle of radius 21cm, if an arc subtends an angle of 60° at the centre, find the length of the arc.

Solution :- radius $r = 21 \text{ cm}$

Angle of sector $\theta = 60^\circ$

$$\text{Length of an arc of a sector} = \frac{\theta}{360} \times 2\pi r$$

$$= \frac{60^\circ}{360} \times 2 \times \frac{22}{7} \times 21$$

$$= \frac{1}{6} \times 2 \times 22 \times 3$$

$$\therefore \text{Length of arc} = 22 \text{ cm}$$

- 26) Find the area of the shaded region in the figure, if ABCD is a square of side 14 cm and APD and BPC are semicircles.

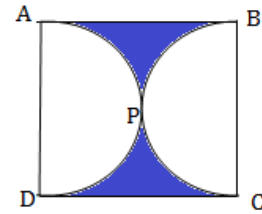

Solution:- Length of side of square = 14 cm

$$\text{Area of square} = 14 \times 14 = 196 \text{ cm}^2 \text{ -----} > (1)$$

$$\text{Radius } r = \frac{14}{2} = 7 \text{ cm}$$

$$\text{Area of semicircle} = \frac{1}{2} \times \pi r^2$$

$$\text{Area of semicircle} = \frac{1}{2} \times \frac{22}{7} \times 7^2$$

$$\text{Area of semicircle} = 11 \times 7 = 77 \text{ cm}^2 \text{ -----} > (2)$$

$$\begin{aligned} \text{Area of shaded portion} &= \text{Area of square} - 2 \times \text{Area of semicircle} \\ &= 196 - 2 \times 77 \\ &= 196 - 154 = 42 \text{ cm}^2 \end{aligned}$$

- 27) Find the area of the shaded region in the adjoining figure, where ABCD is a square of side 14 cm.

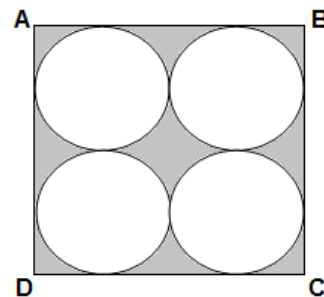

- 28) Find the area of the shaded region in figure, if PQ = 24 cm, PR = 7 cm and 'O' is the centre of the circle.



3 Marks Questions (LA-1)

- 29) The wheels of a car are of diameter 80 cm each. How many complete revolutions does each wheel make in 10 minutes when the car is travelling at a speed of 66 km per hour.

Solution:- Diameter of wheel of a car = $d = 80 \text{ cm}$

$$\text{Radius } r = \frac{80}{2} = 40 \text{ cm}$$

Distance covered by the wheel in one rotation = $2\pi r$

$$= 2 \times \frac{22}{7} \times 40 \text{ cm -----} > (1)$$

$$\text{Distance covered in 10 minutes} = \frac{66}{60} \times 10 = 11 \text{ km (according to data)}$$

$$\text{Distance covered by the wheel in 10 min} = 11 \times 1000 \times 100 \text{ cm -----} > (2)$$

$$\text{Number of rotations of wheels} = \frac{11 \times 1000 \times 100}{2 \times \frac{22}{7} \times 40}$$

$$= \frac{11 \times 1000 \times 100 \times 7}{2 \times 22 \times 40}$$

$$= \frac{11 \times 500 \times 10 \times 7}{2 \times 11 \times 4}$$

$$= \frac{500 \times 10 \times 7}{2 \times 4}$$

$$= 125 \times 5 \times 7$$

Number of rotation of wheel of a car = 4375

- 30) In the adjoining figure a square ABCD of side 7cm is inscribed in a circle. Find the area of the shaded region.

Solution: ABCD is a square

$$\therefore DC = BC = 7\text{cm}$$

$$\text{Diagonal } BD = \sqrt{DC^2 + BC^2} \quad (\because \text{Pythagoras theorem})$$

$$BD = \sqrt{7^2 + 7^2}$$

$$BD = \sqrt{49 + 49}$$

$$BD = \sqrt{2 \times 49}$$

$$BD = 7\sqrt{2}\text{ cm}$$

$$\text{Radius} = \frac{BD}{2} = \frac{7\sqrt{2}}{2}\text{ cm} \quad (\because BD \text{ is a diameter})$$

$$\text{Area of the square} = 7 \times 7 = 49\text{cm}^2 \text{ ---->(1)}$$

$$\text{Area of the circle} = \pi r^2 = \frac{22}{7} \times \frac{7\sqrt{2}}{2} \times \frac{7\sqrt{2}}{2}$$

$$\text{Area of the circle} = 77\text{cm}^2 \text{ ---->(2)}$$

$$\text{Area of shaded region} = \text{Area of the circle} - \text{Area of the square}$$

$$\text{Area of shaded region} = 77 - 49 = 28\text{ cm}^2 \text{ [From (1) and (2)]}$$



- 31) In the adjoining figure a rectangle ABCD is inscribed in a circle. Find the area of the shaded region.

Solution: ABCD is a rectangle

$$AD = 5\text{cm}, DC = 10\text{cm}$$

$$\text{Diagonal } AC = \sqrt{AD^2 + DC^2} \quad (\because \text{Pythagoras theorem})$$

$$AC = \sqrt{5^2 + 10^2}$$

$$AC = \sqrt{25 + 100}$$

$$AC = \sqrt{125} = \sqrt{25 \times 5}$$

$$AC = 5\sqrt{5}\text{ cm}$$

$$\text{Radius} = \frac{AC}{2} = \frac{5\sqrt{5}}{2}\text{ cm} \quad (\because AC \text{ is a diameter.})$$

$$\text{Area of the rectangle} = 10 \times 5 = 50\text{cm}^2 \text{ ----> (1)}$$

$$\text{Area of the circle} = \pi r^2 = \frac{22}{7} \times \frac{5\sqrt{5}}{2} \times \frac{5\sqrt{5}}{2}$$

$$\text{Area of the circle} = 98.2\text{cm}^2 \text{ ----> (2)}$$

$$\text{Area of shaded region} = \text{Area of the circle} - \text{Area of the rectangle}$$

$$\begin{aligned} \text{Area of shaded region} &= 98.2 - 50 \\ &= 48.2\text{ cm}^2 \text{ [}\because \text{From (1) and (2)]} \end{aligned}$$

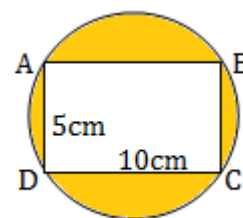

- 32) Find the area of the shaded region in figure, if radii of the two concentric circle with centre O are 7cm and 14cm respectively and $\angle AOC = 40^\circ$.



- 33) In the adjoining figure a square OQSP is inscribed in a quadrant of a circle. If $OP = 15$ cm, find the area of the shaded region. (Take $\pi = 3.14$)

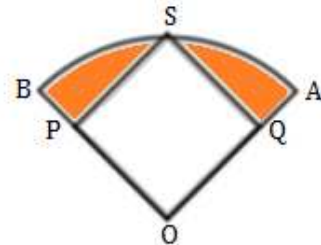

- 34) In the adjoining figure each corner of a square of side 4 cm a quadrant of a circle of radius 1 cm is cut and also a circle of diameter 2 cm is cut as shown in figure. Find the area of the remaining portion of the square.

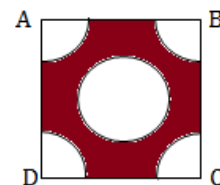

- 35) In the adjoining figure ABCD is a square of side 14 cm. with centres A, B, C and D, four circles are drawn such that each circle touch externally two of the remaining three circles find the area of the shaded region.

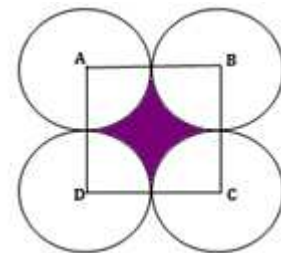

- 36) In the adjoining figure OACB is a quadrant of a circle with centre O and radius 3.5cm, if $OD = 2$ cm, Find the area of the (i) quadrant OACB (ii) Shaded region .

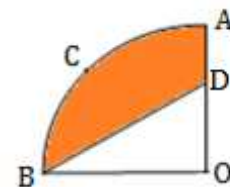

- 37) In the adjoining figure a square OABC is inscribed in a quadrant OPBQ. If $OA = 20$ cm, find the area of the shaded region.

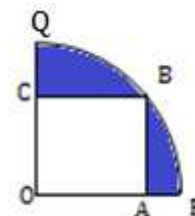

- 38) Find the area of segment AMB, shown in figure if radius of the circle is 14 cm and $\angle AOB = 120^\circ$.

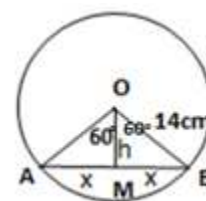

- 39) In the adjoining figure, find the area of the shaded region which is not common between the two quadrants of circles of radius 16cm each.

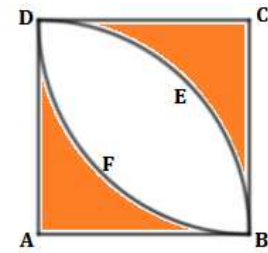

Solution: radius $r = 16\text{cm}$

Area of the shaded region =

{[area of the the square ABCD – area of the the quadrant ABED]

+ [area of the the square ABCD – area of the the quadrant CBFD]}

$$= \left[a^2 - \frac{1}{4} \pi r^2 \right] + \left[a^2 - \frac{1}{4} \pi r^2 \right]$$

$$= \left[2a^2 - \frac{1}{2} \pi r^2 \right]$$

$$= \left[2 \times 16^2 - \frac{1}{2} \times \frac{22}{7} \times 16^2 \right] \quad (\because \text{side of the square} = \text{radius of the quadrant of the circle})$$

$$= \left[512 - \frac{2816}{7} \right]$$

$$= [512 - 402.3]$$

$$= 109.7\text{cm}^2$$

- 40) Find the area of the shaded region in the following figure.

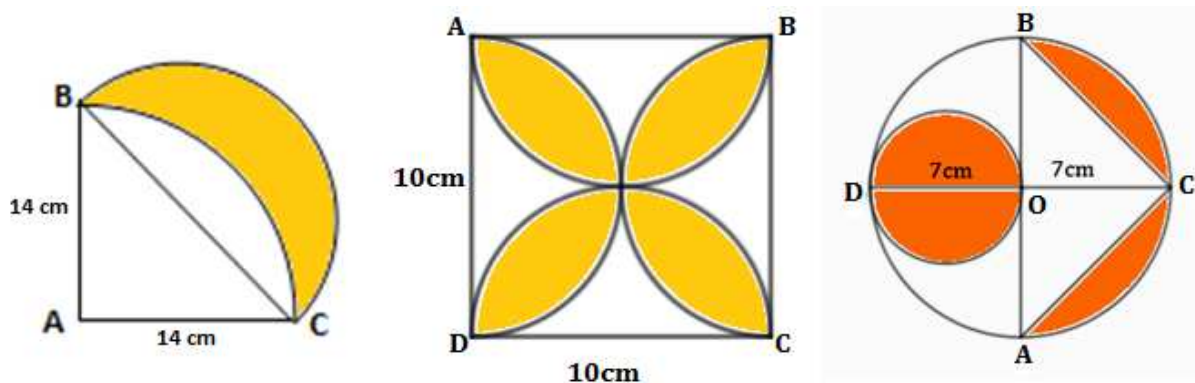

UNIT- 6 :CONSTRUCTIONS

2 Marks Questions (SA)

- 1) Draw a line segment of length 10cm and divide it in the ratio 3: 2. Measure the two parts.

Solution: $AB = 10\text{cm}$ and $AC:BC = 3:2$

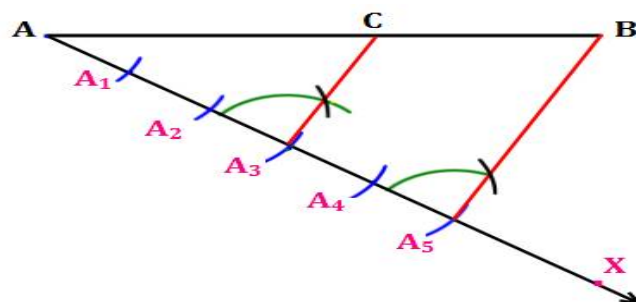

From construction

$AC = 6\text{cm}$ and $BC = 4\text{cm}$

- 2) Draw a line segment of length 8.5cm and divide it in the ratio 3 : 2. Measure the two parts.
- 3) **Draw a circle of radius 3cm. Construct a tangent at any point on the circle.**

Solution : radius $r = 3$ cm

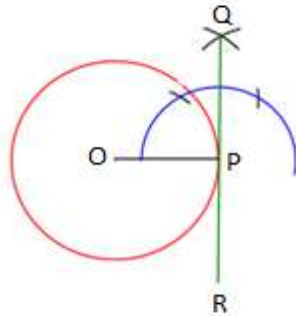

Tangent : QR

- 4) Draw a circle of radius 5cm. Construct a tangent at any point on the circle.
- 5) Draw a circle of radius 5cm. Construct a tangent at any point on the circle.
- 6) Draw a circle of diameter 6cm. Construct two tangents to the circle at the end points of the diameter.
- 7) **Draw a circle of radius 3cm. From a point 7cm away from its centre, construct a pair of tangents to the circle. Measure and write their lengths.**

Solution : radius $r = 3$ cm

$OP = 7$ cm

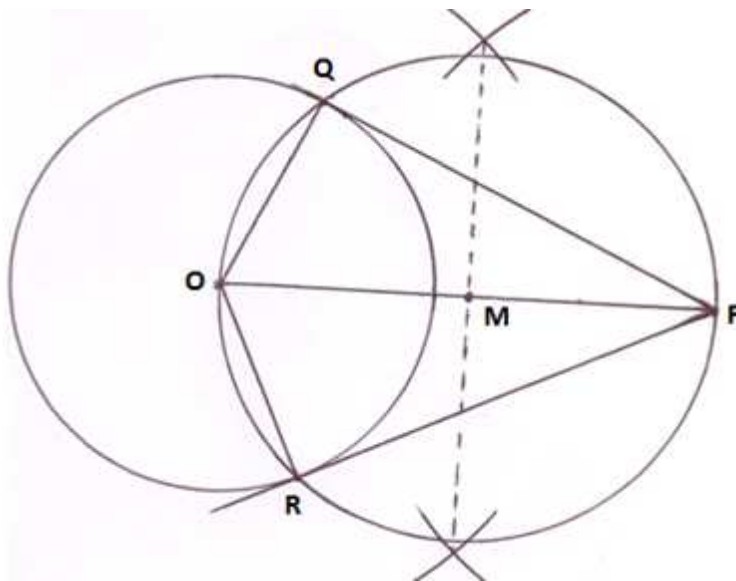

Tangents $PQ = PR = 6.3$ cm

- 8) Draw a circle of radius 3.5cm. From a point 7cm away from its centre, construct a pair of tangents to the circle. Measure and write their lengths.
- 9) Draw a circle of radius 2.5cm. From a point 8 cm away from its centre, construct a pair of tangents to the circle. Measure and write their lengths.
- 10) Draw a circle of diameter 5cm. From a point 9 cm away from its centre, construct a pair of tangents to the circle. Measure and write their lengths.

- 11) Draw a circle of radius 3.5cm. From a point 4cm away from the circle construct the pair of tangent to the circle. Measure and write their lengths.
- 12) Draw a circle of radius 3cm. Take two point P and Q on one of its extended diameter each at a distance of 7cm from its centre. Draw tangents to the circle from these two points P and Q . Measure and write their lengths.
- 13) Draw two concentric circles of radii 2cm and 4cm from a point 7cm away from its centre. construct tangents to the circle. Measure and write their lengths.
- 14) Draw a pair of tangents to a circle of radius 3cm which are inclined to each other at an angle of 60° . Measure and write their lengths.

Solution : radius $r = 3\text{cm}$, Angle between the tangents $= 60^\circ$
 Angle between the radii $= 180^\circ - 60^\circ = 120^\circ$

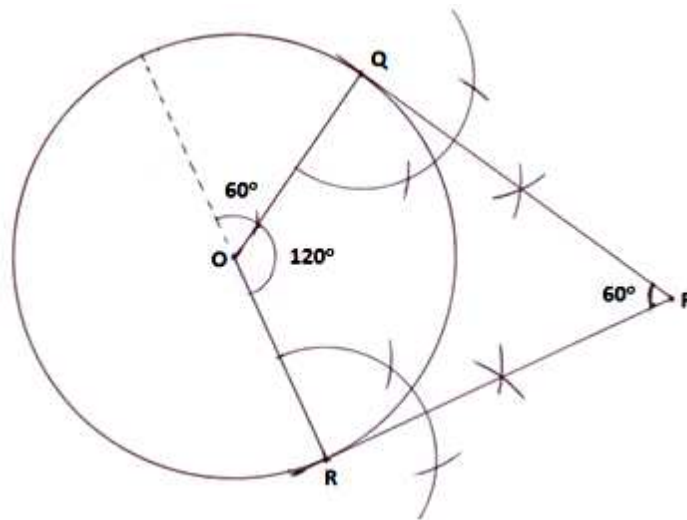

From construction, Tangents $PQ = PR = 5.2\text{ cm}$

- 15) Draw a pair of tangents to a circle of radius 4 cm which are inclined to each other at an angle of 70° . Measure and write their lengths.
- 16) Draw a pair of tangents to a circle of radius 4.5cm which are inclined to each other at an angle of 50° . Measure and write their lengths.
- 17) Draw a pair of tangents to a circle of radius 4cm which are inclined to each other at an angle of 90° . Measure and write their lengths.
- 18) Draw a pair of tangents to a circle of diameter 5cm such that the angle between the radii is 100° . Measure and write their lengths.
- 19) Draw a pair of tangents to a circle of radius 4cm such that the angle between the radii is 80° . Measure and write their lengths.

3/4 Marks Questions (LA -1)

- 20) Draw a triangle ABC with sides $AB = 4\text{ cm}$, $AC = 5\text{ cm}$ and $BC = 6\text{ cm}$. then construct a triangle whose sides are $\frac{2}{3}$ of the corresponding sides of the triangle ABC .

$AB = 4 \text{ cm}$
 $AC = 5 \text{ cm}$
 $BC = 6 \text{ cm}$

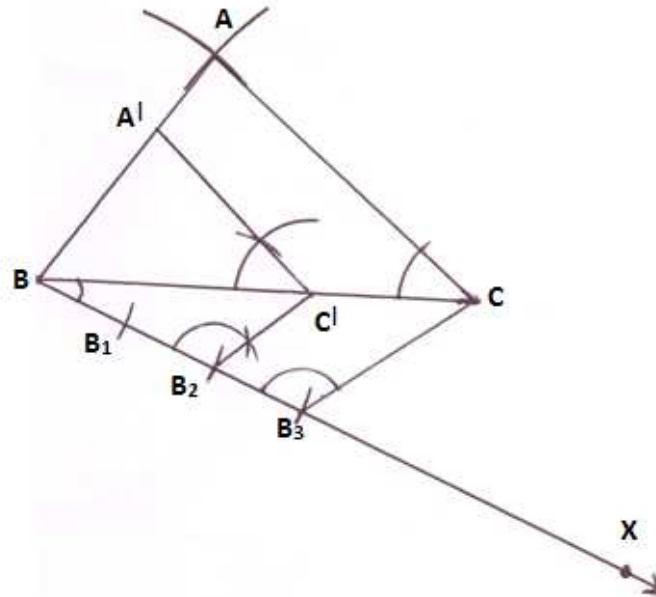

$$\Delta A'BC' \sim \Delta ABC$$

$$\frac{A'B}{AB} = \frac{BC'}{BC} = \frac{A'C'}{AC} = \frac{2}{3}$$

- 21) Construct a triangle of sides 6cm, 7cm and 9 cm, then a triangle similar to its whose sides are $\frac{2}{3}$ of the corresponding sides of the first triangle.
- 22) Draw a triangle ABC with sides $BC = 6 \text{ cm}$, $AB = 5 \text{ cm}$ and $\angle ABC = 60^\circ$, then construct a triangle whose sides are $\frac{4}{5}$ of the corresponding sides of the ΔABC .
- 23) Draw a triangle ABC with side $BC = 7 \text{ cm}$, $\angle A = 45^\circ$ and $\angle B = 105^\circ$, then construct a triangle whose sides are $\frac{3}{4}$ times the corresponding sides of the ΔABC .
- 24) Draw a triangle ABC with sides (other than hypotenuse) are of lengths 3 cm and 4 cm then construct another triangle whose sides are $\frac{3}{4}$ times the corresponding sides of the given triangle.
- 25) Construct a triangle with sides 5 cm, 6 cm and 7cm. and then another triangle whose sides are $\frac{7}{5}$ of the corresponding sides of the first triangle.
- 26) Construct an isosceles triangle whose base is 8cm and altitude 4 cm and then another triangle whose sides are $1\frac{1}{2}$ times the corresponding sides of the isosceles triangle.

UNIT – 7 : COORDINATE GEOMETRY**1 Mark Questions (MCQ)**

- 1) Distance between point $P(x, y)$ and the origin is .
A) $\sqrt{x^2 + y^2}$ B) $\sqrt{x + y}$ C) $\sqrt{x - y}$ D) $\sqrt{(x^2 + y^2)^2}$
- 2) Distance between the points $P(x_1, y_1)$ and $Q(x_2, y_2)$ is
A) $\sqrt{(x_2 + x_1)^2 - (y_2 + y_1)^2}$ B) $\sqrt{(x_2 - x_1)^2 + (y_2 - y_1)^2}$
C) $(x_2 + x_1)^2 - (y_2 + y_1)^2$ D) $(x_2 - x_1)^2 + (y_2 - y_1)^2$
- 3) Distance between the points (4, 6) and (6, 8) is
A) $\sqrt{2}$ units B) 2 units C) $2\sqrt{2}$ units D) 4 units
- 4) Distance between the points (0, 5) and (-5, 0) is
A) $5\sqrt{2}$ units B) 5 units C) $2\sqrt{5}$ units D) $\sqrt{10}$ units
- 5) Distance between origin and the point (4, -3) is
A) 1 unit B) 5 units C) 7 units D) -1 units
- 6) Distance between the points $P(-6, 8)$ and $Q(0, 0)$ is
A) 2 units B) 4 units C) 10 units D) 14 units
- 7) The distance of point $P(x, y)$ from the origin is 5 Units then the co-ordinates of point P are.
A) (-2, 3) B) (1, 2) C) (3, 3) D) (3, 4)
- 8) Co-ordinates of origin are.
A) (1, 1) B) (-1, 0) C) (0, 1) D) (0, 0)
- 9) The coordinates of the mid point of line joining the points (2, 3) and (4, 7) are (3, b) then the value of b is
A) 2 B) 4 C) 5 D) 10
- 10) $(\frac{a}{3}, 4)$ are the co-ordinates of the midpoint of line joining the points (-6, 5) and (-2, 3) then the value of 'a' is
A) -4 B) -12 C) 12 D) -6
- 11) (-1, 1) are the co-ordinates of the mid point of line AB joining the points $A(-3, b)$ and $B(1, b + 4)$, then the value of b is
A) 1 B) -1 C) 2 D) 0
- 12) The perpendicular distance of point A (3, 5) from the x-axis is
A) 3 units B) 5 units C) 6 units D) 8 units

1 Mark Questions (VSA)

- 13) Write the coordinates of the midpoint of the line joining the points $P(x_1, y_1)$ and $Q(x_2, y_2)$.
- 14) Find the distance between points (2, 3) and (4, 1)
- 15) Find the distance between the origin and (12, -5).
- 16) Find the co-ordinates of the midpoint of the line joining the points (2, 3) and (4, 7)

Ans	1) A	2) B	3) C	4) A	5) B	6) C	7) D	8) D	9) C
10) B	11) B	12) B	13) $(\frac{x_1+x_2}{2}, \frac{y_1+y_2}{2})$	14) $2\sqrt{2}$ Units		15) 13 Units		16) (3, 5)	

17) Find the distance of the following points from the origin.

- i) (6, -8) ii) (4, -3) iii) (5, -5) iv) (12, -5) v) (-6, 8)

2 Marks Questions (SA)

18) Find the co-ordinates of the midpoint of the line segment joining the points (8, 5) and (6, 3).

Solution: $(x_1, y_1) = (8, 5)$ and $(x_2, y_2) = (6, 3)$

The co-ordinates of midpoint $(x, y) = (\frac{x_1 + x_2}{2}, \frac{y_1 + y_2}{2})$

$$(x, y) = (\frac{8 + 6}{2}, \frac{5 + 3}{2})$$

$$(x, y) = (\frac{14}{2}, \frac{8}{2})$$

$$(x, y) = (7, 4)$$

19) Find the co-ordinates of the midpoint of the line segment joining by the following pairs of points.

- i) (8, 3)(8, -7) ii) (6, 5)(4, 4) iii) (2, 0)(0, 3)
iv) (2, 8)(6, 8) v) (4, 6) (6, -3)

20) Derive the formula to find the distance between the two points $P(x_1, y_1)$ and $Q(x_2, y_2)$ in the cartecian plane.

Solution: Given two points

$P(x_1, y_1)$ and $Q(x_2, y_2)$

As shown in the figure, draw PR and QS perpendicular to X-axis.

Also draw $PT \perp QS$.

OR = x_1 , OS = x_2

RS = PT = $x_2 - x_1$

RP = ST = y_1 , QS = y_2

TQ = $y_2 - y_1$

From the ΔPTQ

$PQ^2 = PT^2 + TQ^2$ (\because Pythagoras theorem)

$$PQ^2 = (x_2 - x_1)^2 + (y_2 - y_1)^2$$

$$\therefore PQ = \sqrt{(x_2 - x_1)^2 + (y_2 - y_1)^2} \text{ units.}$$

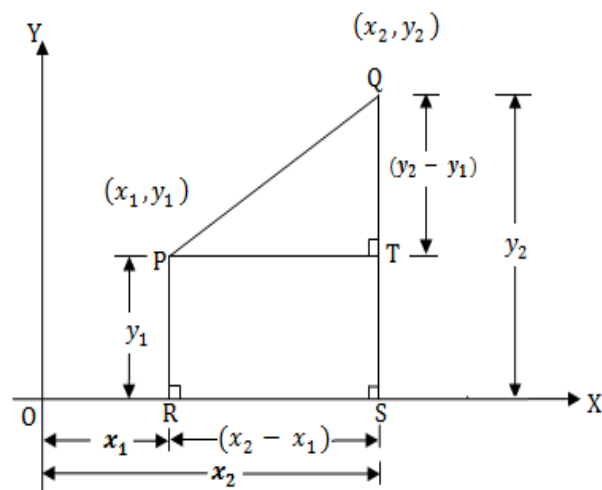

- 21) Find the distance between the points $(0, 0)$ and $(36, 15)$.

Solution: $(x_1, y_1) = (0, 0)$ and $(x_2, y_2) = (36, 15)$

$$d = \sqrt{(x_2 - x_1)^2 + (y_2 - y_1)^2}$$

$$d = \sqrt{(36 - 0)^2 + (15 - 0)^2}$$

$$d = \sqrt{(36)^2 + (15)^2}$$

$$d = \sqrt{1296 + 225}$$

$$d = \sqrt{1521}$$

$$d = 39 \text{ units.}$$

- 22) Find the distance between $(-5, -7)$ and $(-1, 3)$.

- 23) Find the distance between (a, b) and $(-a, -b)$.

- 24) Find the distance between the following pair of points.

i) $(6, 4)$ & $(3, 1)$ ii) $(8, 6)$ & $(3, 1)$ iii) $(6, 4)$ & $(3, 1)$

iv) $(1, 7)$ & $(4, 2)$ v) $(-1, -1)$ & $(-4, 4)$

- 25) If the distance between $P(2, -3)$ and $Q(10, y)$ is 10 units find the value of y .

- 26) Find the point on the x -axis from which $(7, 6)$ and $(-3, 4)$ are equidistant.

Solution:- $(7, 6)$ and $(-3, 4)$

The point $(x, 0)$ is equidistant from them.

$$(x - 7)^2 + (0 - 6)^2 = [(x - (-3))]^2 + (0 - 4)^2$$

$$(x - 7)^2 + 36 = (x + 3)^2 + 16$$

$$x^2 - 14x + 49 + 36 = x^2 + 6x + 9 + 16$$

$$85 - 25 = 20x$$

$$20x = 60$$

$$x = 3$$

The point on x -axis is $(x, 0) = (3, 0)$

- 27) Find the point on the x -axis which is equidistant from points $(2, -5)$ and $(-2, 9)$.

- 28) If the point $P(x, y)$ is equidistant from points $(6, 2)$ and $(-2, 6)$, prove that $y = 2x$.

- 29) $A(6, 1)$, $B(8, 2)$, $C(9, 4)$ and $D(p, 3)$ are the vertices of a parallelogram. Find the value of 'p'.

Solution :- The diagonals of a parallelogram bisect each other.

The co-ordinates of the mid point of AC = The coordinates of the midpoint of BD

$$M(x, y) = \left(\frac{6 + 9}{2}, \frac{1 + 4}{2} \right) = \left(\frac{p + 8}{2}, \frac{3 + 2}{2} \right)$$

$$M(x, y) = \left(\frac{15}{2}, \frac{5}{2} \right) = \left(\frac{p + 8}{2}, \frac{5}{2} \right)$$

$$\therefore \frac{p + 8}{2} = \frac{15}{2}$$

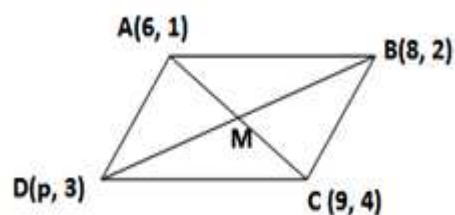

$$p + 8 = 15$$

$$p = 15 - 8$$

$$\therefore p = 7$$

3 Marks Questions (LA -1)

30) Show that the following points form an isosceles triangle .

A(5, -2), B(6, 4) and C(7, -2)

Solution : $d = \sqrt{(x_2 - x_1)^2 + (y_2 - y_1)^2}$

$$AB = \sqrt{(6 - 5)^2 + [4 - (-2)]^2}$$

$$AB = \sqrt{(1)^2 + (6)^2}$$

$$AB = \sqrt{1 + 36} = \sqrt{37} \text{ Units}$$

$$BC = \sqrt{(6 - 7)^2 + [4 - (-2)]^2}$$

$$BC = \sqrt{(-1)^2 + (6)^2}$$

$$BC = \sqrt{1 + 36} = \sqrt{37} \text{ Units}$$

$$AC = \sqrt{(7 - 5)^2 + [-2 - (-2)]^2}$$

$$AC = \sqrt{(2)^2 + (-2 + 2)^2}$$

$$AC = \sqrt{4 + 0} = 2 \text{ units.}$$

$$\therefore AB = BC = \sqrt{37} \text{ units.}$$

The given points form an isosceles triangle.

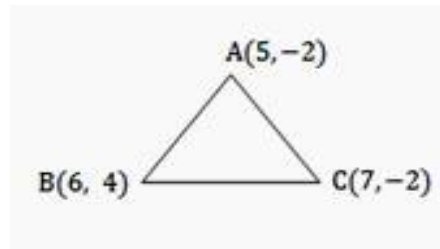

31) Show that (3, 0) (6, 4) (-1, 3) are the vertices of a right angled triangle.

32) Show that (9, 0)(9, 6)(-9, 6)and (-9, 0)are the vertices of a rectangle.

33) Find the area of a triangle whose vertices are(10, -6)(2, 5)and(-1, 3).

$$\text{Solution: } x_1 = 10, \quad x_2 = 2, \quad x_3 = -1,$$

$$y_1 = -6, \quad y_2 = 5, \quad y_3 = 3$$

$$\text{The area of a triangle} = \frac{1}{2} [x_1(y_2 - y_3) + x_2(y_3 - y_1) + x_3(y_1 - y_2)]$$

$$= \frac{1}{2} [10(5 - 3) + 2(3 - (-6)) + (-1)(-6 - 5)]$$

$$= \frac{1}{2} [10(2) + 2(9) + (-1)(-11)]$$

$$= \frac{1}{2} (20 + 18 + 11)$$

$$= \frac{1}{2} (49)$$

$$= \frac{49}{2} = 24.5 \text{ square units.}$$

34) Find the area of the triangle having the following vertices.

i) (2, -2), (-2, 1), (5, 2) ii) (2, 3), (-1, 0), (2, -4)

iii) (-5, 7), (-4, -5), (4, 5) iv) (-5, -1), (3, -5), (5, 2)

v) A(3, 8) B(-4, 2), C(5, -1) vi) A(1, -1), B(-4, 6), C(-3, -5)

35) If the points (-3, 12), (7, 6) and (x, 9) are collinear find the value of x.

Solution: $x_1 = -3, \quad x_2 = 7, \quad x_3 = x,$

$y_1 = 12, \quad y_2 = 6, \quad y_3 = 9$

If the points are collinear then the area of the triangle is zero.

$$\therefore \frac{1}{2} [x_1(y_2 - y_3) + x_2(y_3 - y_1) + x_3(y_1 - y_2)] = 0$$

$$\frac{1}{2} [-3(6 - 9) + 7(9 - 12) + x(12 - 6)] = 0$$

$$\frac{1}{2} [-3(-3) + 7(-3) + x(6)] = 0$$

$$\frac{1}{2} [9 - 21 + 6x] = 0$$

$$\frac{1}{2} [-12 + 6x] = 0$$

$$-12 + 6x = 0$$

$$6x = 12$$

$$\therefore x = 2$$

Alternate Method:

$$\text{Area of Triangle} = \frac{1}{2}$$

$$\begin{vmatrix} -3 & 12 \\ 7 & 6 \\ x & 9 \\ -3 & 12 \end{vmatrix}$$

$$0 = \frac{1}{2} [\{(-3)6 + 7(9) + x(12)\} - \{12(7) + 6(x) + 9(-3)\}]$$

$$0 = \frac{1}{2} [\{-18 + 63 + 12x\} - \{84 + 6x - 27\}]$$

$$0 = \frac{1}{2} [\{45 + 12x\} - \{57 + 6x\}]$$

$$0 = \frac{1}{2} [45 + 12x - 57 - 6x]$$

$$0 = \frac{1}{2} [6x - 12]$$

$$6x - 12 = 0$$

$$\therefore x = 2$$

36) Find the value of 'P' if the following points are collinear.

- i) (3, 2), (4, p), (5, 3) ii) (-3, 9), (2, p), (4, -5)

37) Show that the points (1, -1), (5, 2) and (9, 5) are collinear using distance formula.

38) Find the co-ordinates of the points which divides the line segment joining the points (-5, 11) and (4, -7) in the ratio 7:2.

Solution: - $(x_1, y_1) = (-5, 11)$, $(x_2, y_2) = (4, -7)$, $m_1 : m_2 = 7 : 2$

$$P(x, y) = \left(\frac{m_1 x_2 + m_2 x_1}{m_1 + m_2}, \frac{m_1 y_2 + m_2 y_1}{m_1 + m_2} \right)$$

$$P(x, y) = \left(\frac{7(4) + 2(-5)}{7 + 2}, \frac{7(-7) + 2(11)}{7 + 2} \right)$$

$$P(x, y) = \left(\frac{28 - 10}{9}, \frac{-49 + 22}{9} \right)$$

$$P(x, y) = \left(\frac{18}{9}, \frac{-27}{9} \right)$$

$$P(x, y) = (2, -3)$$

39) Find the ratio in which the point (2, 5) divides the line segment joining (8, 2) and (-6, 9).

40) Find the ratio in which (-6, a) divides the line segment joining (-3, -1) and (-8, 9) and find the value of 'a'.

41) O is the origin. B(-6, 9) and C(12, -3) are the vertices of the ΔABC . If the point P divides OB in the ratio 1 : 2 and the point Q divides OC in the ratio 1 : 2. show that $PQ = \frac{1}{3} BC$.

42) In the given figure, A(0, 6), B(8, 0), and C(5, 8) are the vertices of a ΔABC . If $CD \perp AB$, find the length of CD.

43) Find the coordinates of the points of trisection of the line segment joining the points A(2, -2) and B(-7, 4)

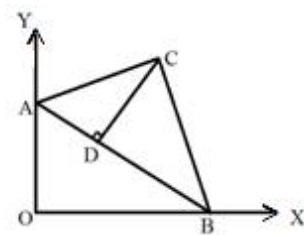

4 Marks Questions (LA-2)

44) In the adjoining figure D, E and F are the mid points of AB, BC and AC respectively. Find the area of the triangle DEF.

Solution: D, E and F are the mid points of AB, BC and AC respectively.

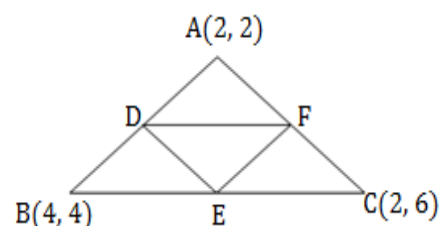

The coordinates of mid point D = $\left(\frac{4+2}{2}, \frac{4+2}{2}\right) = (3, 3) = (x_1, y_1)$

The coordinates of mid point E = $\left(\frac{4+2}{2}, \frac{4+6}{2}\right) = (3, 5) = (x_2, y_2)$

The coordinates of mid point F = $\left(\frac{2+2}{2}, \frac{6+2}{2}\right) = (2, 4) = (x_3, y_3)$

$$\therefore x_1 = 3, \quad x_2 = 3, \quad x_3 = 2 \quad \text{and} \quad y_1 = 3, \quad y_2 = 5, \quad y_3 = 4$$

Area of the $\Delta DEF = \frac{1}{2} [x_1(y_2 - y_3) + x_2(y_3 - y_1) + x_3(y_1 - y_2)]$

$$= \frac{1}{2} [3(5 - 4) + 3(4 - 3) + 2(3 - 5)]$$

$$= \frac{1}{2} [3(1) + 3(1) + 2(-2)]$$

$$= \frac{1}{2} [3 + 3 - 4]$$

$$= \frac{1}{2} [2]$$

$$= 1 \text{ Square unit.}$$

5 Marks Questions (LA -3)

- 45) In the adjoining figure D(3, 3), E(3, 5) and F(2, 4) are the mid points of AB, BC and AC respectively. Find the coordinates of the vertices of the triangle ABC.

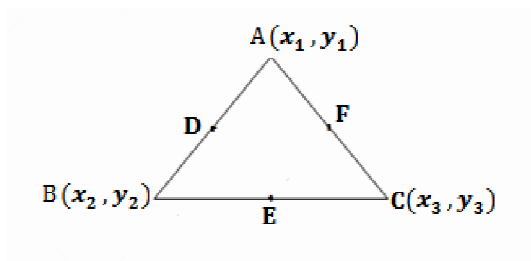

Solution: D, E and F are the mid points of AB, BC and AC respectively.

The coordinates of mid point D $(3, 3) = \left(\frac{x_1 + x_2}{2}, \frac{y_1 + y_2}{2}\right)$

The coordinates of mid point D $\left(\frac{6}{2}, \frac{6}{2}\right) = \left(\frac{x_1 + x_2}{2}, \frac{y_1 + y_2}{2}\right)$

$$x_1 + x_2 = 6 \text{ -----}>(1) \quad \text{and} \quad y_1 + y_2 = 6 \text{ -----}>(2)$$

The coordinates of mid point E $(3, 5) = \left(\frac{x_2 + x_3}{2}, \frac{y_2 + y_3}{2}\right)$

The coordinates of mid point E $\left(\frac{6}{2}, \frac{10}{2}\right) = \left(\frac{x_2 + x_3}{2}, \frac{y_2 + y_3}{2}\right)$

$$x_2 + x_3 = 6 \text{ -----}>(3) \quad \text{and} \quad y_2 + y_3 = 10 \text{ -----}>(4)$$

The coordinates of mid point F (2, 4) = $\left(\frac{x_1 + x_3}{2}, \frac{y_1 + y_3}{2}\right)$

The coordinates of mid point F $\left(\frac{4}{2}, \frac{8}{2}\right) = \left(\frac{x_1 + x_3}{2}, \frac{y_1 + y_3}{2}\right)$

$$x_1 + x_3 = 4 \text{ -----}>(5) \quad \text{and} \quad y_1 + y_3 = 8 \text{ -----}>(6)$$

By adding (1), (3) & (5)

$$2x_1 + 2x_2 + 2x_3 = 16$$

$$x_1 + x_2 + x_3 = 8$$

$$\therefore x_1 = 8 - 6 = 2$$

$$\therefore x_2 = 8 - 4 = 4$$

$$\therefore x_3 = 8 - 6 = 2$$

$$\therefore A(x_1, y_1) = A(2, 2),$$

By adding (2), (4) & (6)

$$2y_1 + 2y_2 + 2y_3 = 24$$

$$y_1 + y_2 + y_3 = 12$$

$$\therefore y_1 = 12 - 10 = 2$$

$$\therefore y_2 = 12 - 8 = 4$$

$$\therefore y_3 = 12 - 6 = 6$$

$$B(x_2, y_2) = B(4, 4), \quad C(x_3, y_3) = C(2, 6)$$

Unit-8: REAL NUMBERS

1 MARKS QUESTIONS (MCQ)

- 72 and 28 can be expressed using Euclid's division algorithm as

A) $28 = (72 - 16) \times 2$	B) $72 = (28 \times 2) + 16$
C) $72 = (28 \times 2) - 16$	D) $16 = 72 - (28 + 2)$
- The HCF of 26 and 91 is

A) 7	B) 13	C) 20	D) 26
------	-------	-------	-------
- If the HCF of 6 and 20 is 2, then the LCM is

A) 40	B) 120	C) 60	D) 240
-------	--------	-------	--------
- Which of the following number is not a product of prime factors

A) 35	B) 26	C) 23	D) 15
-------	-------	-------	-------
- If $x = \frac{p}{q}$ ($q \neq 0$) is a rational number having terminating decimal expression then the factor of 'q' are in the form

A) $2^n \cdot 5^m$ here m, n are, non negative integers
B) $3^n \cdot 5^m$ here m, n are non positive integers
C) $5^n \cdot 7^m$ here m, n are non negative integers
D) $2^n \cdot 7^m$ here m, n are non positive integers

Step 3: $45 = (36 \times 1) + 9$

Step 4: $36 = (9 \times 4) + 0$ Now the remainder is 0

\therefore The H.C.F = 9

$$\text{L.C.M.} = \frac{306 \times 657}{9} \left[\because \text{L.C.M} = \frac{\text{Product of numbers}}{\text{H.C.F}} \right]$$

$$\text{L.C.M.} = 34 \times 657$$

$$\text{L.C.M.} = 22338$$

- 17) **There is a circular path around a sports field. Sonia takes 18 minutes to drive one round of the field, while Ravi takes 12 minutes for the same. Suppose they both start at the same point and at the same time, and go in the same direction. After how many minutes will they meet again at the starting point?**

Solution: - they will meet again after a time equal to L.C.M of the time taken.

$$18 = 2 \times 3 \times 3 = 2 \times 3^2$$

$$12 = 2 \times 2 \times 3 = 2^2 \times 3$$

$$\text{L.C.M.} = 2^2 \times 3^2 = 36$$

\therefore They meet again at the starting point after 36 minutes.

- 18) **Prove that $5 - \sqrt{3}$ is an irrational number.**

Solution: - Let us assume that $5 - \sqrt{3}$ is a rational number.

That is $5 - \sqrt{3} = \frac{p}{q}$ ($p, q \in \mathbb{Z}$ and $q \neq 0$) p, q are co- primes.

$$5 - \frac{p}{q} = \sqrt{3}$$

$$\sqrt{3} = \frac{5q-p}{q}$$

$\Rightarrow \sqrt{3}$ is a rational number [$\because \frac{5q-p}{q}$ is a rational number.]

But this contradicts the fact that $\sqrt{3}$ is an irrational.

\therefore our assumption is wrong .

Hence $5 - \sqrt{3}$ is an irrational number.

- 19) If $\sqrt{2}$ is an irrational number, prove that $6 + \sqrt{2}$ is an irrational number.

- 20) Prove that the following are irrational numbers.

i) $3\sqrt{2}$ ii) $5 + \sqrt{3}$ iii) $3 + 2\sqrt{5}$ iv) $3 - 2\sqrt{5}$ v) $\frac{2+\sqrt{3}}{5}$ vi) $\sqrt{2} + \sqrt{3}$

- 21) **Show that $\frac{35}{50}$ has terminating decimal expansion without long division.**

Solution : $50 = 2 \times 5 \times 5 = 2^1 \times 5^2$

$$\frac{35}{50} = \frac{35}{2^1 \times 5^2}$$

The denominator is in the form $2^n \times 5^m$ and $n = 1, m = 2$ are non negative integers

\therefore This is a terminating decimal expansion.

- 22) Without long method of division show that $\frac{77}{210}$ has non terminating recurring decimal expansion.

Solution : $210 = 2 \times 3 \times 5 \times 7$

$$\frac{77}{210} = \frac{77}{2 \times 3 \times 5 \times 7}$$

The denominator is not in the form $2^n \times 5^m$.

\therefore This is a non terminating recurring decimal expansion.

- 23) Without long division method, find whether the following rational numbers have terminating decimal expansions.

i) $\frac{17}{8}$ ii) $\frac{64}{455}$ iii) $\frac{29}{343}$ iv) $\frac{23}{200}$

- 24) Find after how many places of decimal the decimal form of the number $\frac{27}{2^3 \cdot 5^4 \cdot 3^2}$ will terminate.

Solution : $\frac{27}{2^3 \cdot 5^4 \cdot 3^2}$

$$= \frac{27}{8 \times 625 \times 9}$$

$$= \frac{3}{8 \times 625}$$

$$= \frac{3}{5000}$$

$$= \frac{3 \times 2}{5000 \times 2}$$

$$= \frac{6}{10000} = 0.0006$$

\therefore After 4 decimal places it terminates.

3 Marks Questions (LA-1)

- 25) Find the H.C.F. and L.C.M. of 6, 72 and 120 using prime factorization method.

Solution: $6 = 2 \times 3 = 2^1 \times 3^1$

$$72 = 2 \times 2 \times 2 \times 3 \times 3 = 2^3 \times 3^2$$

$$120 = 2 \times 2 \times 2 \times 3 \times 5 = 2^3 \times 3^1 \times 5^1$$

$$\text{H.C.F} = 2^1 \times 3^1 = 6 \quad (\because \text{HCF} = \text{product of common prime factors})$$

$$\text{L.C.M.} = 2^3 \times 3^2 \times 5^1$$

$$\text{L.C.M.} = 8 \times 9 \times 5$$

$$\text{L.C.M.} = 360$$

- 26) Find the H.C.F and L.C.M of the following numbers using prime factorization method.

(i) 12, 15 and 21

(ii) 17, 23 and 29

(iii) 8, 9 and 25

27) Prove that $\sqrt{2}$ is an irrational number.

Solution: - Let us assume that $\sqrt{2}$ is a rational number.

That is $\sqrt{2} = \frac{p}{q}$ ($p, q \in \mathbb{Z}$ and $q \neq 0$) p, q are co- primes.

$$\sqrt{2} \times q = p$$

$$\text{Squaring on both sides, } 2 \times q^2 = p^2 \text{ -----}(1)$$

$$\Rightarrow 2 \text{ divides } p^2.$$

$$\therefore 2 \text{ divides } p. \quad \Rightarrow p \text{ is an even number}$$

Let $p = 2k$, here k is an integer.

$$p^2 = (2k)^2$$

$$2 \times q^2 = (2k)^2 \text{ [from eqn. (1)]}$$

$$\Rightarrow 2q^2 = 4k^2$$

$$q^2 = 2k^2 \quad \Rightarrow q \text{ is an even number}$$

\therefore Both p and q are even numbers.

$\Rightarrow 2$ is a common factor of p and q .

But this contradicts the fact that p and q are co- primes.

\therefore our assumption is wrong .

Hence $\sqrt{2}$ is an irrational number.

28) Prove that $\sqrt{3}$ is an irrational number.

29) Prove that $\sqrt{5}$ is an irrational number.

30) Prove that $\frac{3}{\sqrt{2}}$ is an irrational number.

UNIT – 9: POLYNOMIALS

1 Mark Questions (MCQ)

1) In the adjoining figure, graph of a polynomial is given. The number of zeros of the polynomial is,

- A) 1 B) 2
C) 3 D) 4

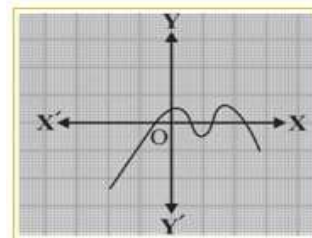

- 2) Which of the following is a zero of the polynomial $x^2 + 4x + 4$?
A) 2 B) -2 C) 4 D) -4
- 3) The degree of the polynomial $-4x^2 + 5x^3 + x - \sqrt{2}$ is
A) 0 B) 1 C) 2 D) 3
- 4) $f(x) = x^2 - 9x + 20$ is a quadratic polynomial. The value of $f(0)$ is
A) 20 B) 11 C) -20 D) 29

- 5) If the zero of the polynomial $x^2 + kx + 4$ is -2 , then the value of 'k' is
A) 4 B) -2 C) -4 D) 2
- 6) Which of the following is a zero of the polynomial $x^2 - 3$?
A) 3 B) -3 C) $\sqrt{3}$ D) 9
- 7) If $x^5 + a^5$ is divided by $(x + a)$, the remainder is
A) a^5 B) $2a^5$ C) 0 D) 5
- 8) If $x^5 + a^5$ is divided by $(x - a)$, the remainder is
A) a^5 B) $2a^5$ C) 0 D) 5
- 9) If $(x - 7)$ is the factor of $(x^2 - k)$ then the value of 'k' is
A) 49 B) 7 C) -7 D) -49
- 10) If the zeros of the polynomial $3x^2 + 8x + k$ are reciprocal to each other, then the value of 'k' is
A) 3 B) -3 C) $\frac{1}{3}$ D) $-\frac{1}{3}$
- 11) If the sum of the zeros of the quadratic polynomial $kx^2 + 2x + 3k$ is equal to the product of its zeros, then the value of k is
A) $\frac{1}{3}$ B) $-\frac{1}{3}$ C) $\frac{2}{3}$ D) $-\frac{2}{3}$
- 12) The zeros of the quadratic polynomial $x^2 + 88x + 125$ are,
A) Both positive B) Both negative
C) One positive and one negative D) Both equal.

1 Mark Questions (VSA)

- 13) What is the maximum number of zeros of the polynomial $x^3 + x + 2 + 4x^5$?
- 14) Write the degree of the polynomial $2 - x^3$.
- 15) If $p(x) = 2x^2 + 3x + 2$ then, find the value of $p(2)$.
- 16) If $f(x) = x^2 - 4$ then, find the value of $f(4)$.
- 17) If $f(x) = 7x^2 + 2x + 14$ then, find the value of $f(-1)$.
- 18) Write the general form of a linear polynomial.
- 19) What is the degree of a linear polynomial?
- 20) Write the general form of a quadratic polynomial.
- 21) What is the degree of a quadratic polynomial?
- 22) Write the general form of a Cubic polynomial.
- 23) What is the degree of a cubic polynomial?
- 24) $f(x) = 10$, which type of a polynomial is this?
- 25) Find the zero of the polynomial $f(x) = 3x + 1$.

Ans	1) D	2) B	3) D	4) A	5) A	6) C	7) C	8) B	9) A
10) A	11) D	12) B	13) 5	14) 3	15) 16	16) 12	17) 19		
18) $ax + b$ ($a \neq 0$)			19) 1	20) $ax^2 + bx + c$ ($a \neq 0$)				21) 2	
22) $ax^3 + bx^2 + cx + d$ ($a \neq 0$)				23) 3	24) Constant polynomial			25) $-\frac{1}{3}$	

3 Marks Questions (SA)

26) If the sum of zeros is $\sqrt{2}$ and the product of zeros is $\frac{1}{3}$ find the polynomial.

Solution:- Let the zeros be α and β .

$$\alpha + \beta = \sqrt{2} \text{ and } \alpha\beta = \frac{1}{3}$$

the desired polynomial is $x^2 - (\alpha + \beta)x + \alpha\beta$

$$= x^2 - (\sqrt{2})x + \frac{1}{3}$$

$$= 3x^2 - 3\sqrt{2}x + 1 \text{ (multiply each term by 3)}$$

\therefore the required polynomial is $3x^2 - 3\sqrt{2}x + 1$

27) Find the polynomial whose sum of zeros is $\frac{1}{4}$ and the product of the zeros is -1 .

28) Find the polynomial whose sum of zeros is $\frac{1}{4}$ and the product of the zeros is $-\frac{1}{4}$.

29) Find the polynomial whose sum of zeros is -3 and the product of the zeros is 2 .

30) Find a polynomial whose zeros are $\sqrt{3}$ and $-\sqrt{3}$.

Solution:- Let the zeros be α and β .

$$\alpha = \sqrt{3}$$

$$\beta = -\sqrt{3}$$

$$\alpha + \beta = \sqrt{3} + (-\sqrt{3}) = 0$$

$$\alpha\beta = (\sqrt{3})(-\sqrt{3}) = -(\sqrt{3})^2 = -3$$

The desired polynomial is $x^2 - (\alpha + \beta)x + \alpha\beta$

$$= x^2 - (0)x + (-3)$$

$$= x^2 - 3$$

\therefore The required polynomial is $x^2 - 3$.

31) If the product of the zeros of the polynomial $kx^2 - 6x - 6$ is 4 , find the value of k .

Solution:- Let the zeros be α and β .

Comparing $kx^2 - 6x - 6$ with $ax^2 + bx + c$

$$a = k, \quad b = -6, \quad c = -6$$

$$\alpha.\beta = \frac{c}{a}$$

$$4 = \frac{-6}{k} \quad [\because \text{product of the zeros} = 4]$$

$$k = \frac{-6}{4} \quad \therefore k = -\frac{3}{2}$$

- 32) If the difference of the zeros of the polynomial $3x^2 - x - 4$ is $\frac{7}{3}$, find the difference of the squares of the zeros.

Solution:- Let the zeros be α and β .

Comparing $3x^2 - x - 4$ with $ax^2 + bx + c$

$$a = 3, \quad b = -1, \quad c = -4$$

$$\alpha - \beta = \frac{7}{3} \quad \text{----->(1) } (\because \text{ data})$$

$$\alpha + \beta = \frac{-b}{a}$$

$$\alpha + \beta = \frac{-(-1)}{3} = \frac{1}{3} \quad \text{----->(2)}$$

$$\alpha^2 - \beta^2 = (\alpha + \beta)(\alpha - \beta) \quad [\because \text{ From (1) and (2)}]$$

$$\alpha^2 - \beta^2 = \frac{1}{3} \times \frac{7}{3}$$

$$\therefore \alpha^2 - \beta^2 = \frac{7}{9}$$

3 Marks Questions (LA-1)

- 33) If one zero of the polynomial $(a^2 + 9)x^2 + 13x + 6a$ is reciprocal of the other, find the value of a .

Solution: comparing $(a^2 + 9)x^2 + 13x + 6a$ with $ax^2 + bx + c$,

$$a = (a^2 + 9), \quad b = 13, \quad c = 6a$$

Let the zeros be α and $\frac{1}{\alpha}$ (\because zeros are reciprocal to each other)

$$\alpha \cdot \beta = \frac{c}{a}$$

$$\alpha \cdot \frac{1}{\alpha} = \frac{6a}{(a^2+9)}$$

$$1 = \frac{6a}{(a^2+9)}$$

$$\therefore (a^2 + 9) = 6a$$

$$\therefore a^2 - 6a + 9 = 0$$

$$(a - 3)^2 = 0$$

$$a - 3 = 0$$

$$\therefore a = 3$$

- 34) Find the zeros of the polynomial $6x^2 - 3 - 7x$. Also verify the relation between zeros and the co-efficient.

Solution:- $6x^2 - 3 - 7x$

$$= 6x^2 - 7x - 3$$

$$= 6x^2 - 9x + 2x - 3$$

$$= 3x(2x - 3) + 1(2x - 3)$$

$$= (3x + 1)(2x - 3)$$

$$\Rightarrow \text{The zeros, } x = -\frac{1}{3} \text{ and } x = \frac{3}{2}$$

$$6 \times 3 = 18$$

$$9 \times 2 = 18$$

$$-9 + 2 = -7$$

$$\text{The sum of the zeros} = -\frac{1}{3} + \frac{3}{2} = \frac{-2+9}{6} = \frac{7}{6} = \frac{-(-7)}{6} = \frac{-(\text{Co-efficient of } x)}{(\text{Co-efficient of } x^2)}$$

$$\text{The product of the zeros} = -\frac{1}{3} \times \frac{3}{2} = \frac{-1}{2} = \frac{-3}{6} = \frac{\text{Constant}}{\text{Co-efficient of } x^2}$$

- 35) Find the zeros of the polynomial $4s^2 - 4s + 1$, and verify the relation between zeros and the co-efficient.
- 36) Find the zeros of the polynomial $x^2 - \frac{x}{3} - \frac{4}{3}$, and verify the relation between zeros and the co-efficient.
- 37) Find the zeros of the polynomial $4u^2 - 8u$, and verify the relation between zeros and the co-efficient.
- 38) If α, β and γ are zeros of the polynomial $3x^3 - 5x^2 - 11x - 3$, find the value of
 (i) $\alpha + \beta + \gamma$ (ii) $\alpha\beta + \beta\gamma + \gamma\alpha$ (iii) $\alpha\beta\gamma$

Solution: compare $3x^3 - 5x^2 - 11x - 3$ with $ax^3 + bx^2 + cx + d$,

$$a = 3, \quad b = -5, \quad c = -11, \quad d = -3$$

$$(i) \alpha + \beta + \gamma = \frac{-b}{a}$$

$$\alpha + \beta + \gamma = \frac{-(-5)}{3} = \frac{5}{3}$$

$$(ii) \alpha\beta + \beta\gamma + \gamma\alpha = \frac{c}{a}$$

$$\alpha\beta + \beta\gamma + \gamma\alpha = \frac{-11}{3}$$

$$(iii) \alpha\beta\gamma = \frac{-d}{a}$$

$$\alpha\beta\gamma = \frac{-(-3)}{3} = 1$$

- 39) If α and β are zeros of the polynomial $x^2 - 2x - 8$, find the value of $\alpha^2\beta + \alpha\beta^2$.

Solution: compare $x^2 - 2x - 8$ with $ax^2 + bx + c$,

$$a = 1, \quad b = -2, \quad c = -8.$$

$$\text{Sum of the zeros } \alpha + \beta = \frac{-b}{a}$$

$$\alpha + \beta = \frac{-(-2)}{1} = 2 \text{ -----}>(1)$$

- 44) Divide the polynomial $3x^4 + 5x^3 - 7x^2 + 2x + 2$ by the polynomial $x^2 + 3x + 1$.
Verify if the second polynomial is a factor of the first polynomial.

Solution :-

$$\begin{array}{r}
 \overline{3x^2 - 4x + 2} \\
 x^2 + 3x + 1 \overline{) 3x^4 + 5x^3 - 7x^2 + 2x + 2} \\
 \underline{3x^4 + 9x^3 + 3x^2} \\
 (-) (-) \\
 -4x^3 - 10x^2 + 2x + 2 \\
 \underline{-4x^3 - 12x^2 - 4x} \\
 (+) (+) \\
 2x^2 + 6x + 2 \\
 \underline{2x^2 + 6x + 2} \\
 (-) (-) (-) \\
 \hline
 0
 \end{array}$$

\therefore Quotient = $3x^2 - 4x + 2$ and remainder = 0

Since the remainder is zero, $x^2 + 3x + 1$ is factor of $3x^4 + 5x^3 - 7x^2 + 2x + 2$.

- 45) Divide the polynomial $2t^4 + 3t^3 - 2t^2 - 9t - 12$ by the polynomial $t^2 - 3$ and verify if the second polynomial is a factor of the first polynomial.
- 46) Divide the polynomial $x^5 - 4x^3 + x^2 + 3x + 1$ by the polynomial $x^3 - 3x + 1$ and verify if the second polynomial is a factor of the first polynomial.

- 47) Obtain all other zeros of $3x^4 - 15x^3 + 13x^2 + 25x - 30$, If of its two zeros are $\sqrt{\frac{5}{3}}$ and $-\sqrt{\frac{5}{3}}$.

Solution: let $f(x) = 3x^4 - 15x^3 + 13x^2 + 25x - 30$

$\sqrt{\frac{5}{3}}$ and $-\sqrt{\frac{5}{3}}$ are the two zeros of $f(x)$.

$\therefore \left(x - \sqrt{\frac{5}{3}}\right) \left(x + \sqrt{\frac{5}{3}}\right)$ are the factors of $f(x)$.

$$\left(x - \sqrt{\frac{5}{3}}\right) \left(x + \sqrt{\frac{5}{3}}\right) = \left(x^2 - \frac{5}{3}\right)$$

$$= \frac{3x^2 - 5}{3} = 0 \quad \Rightarrow 3x^2 - 5 = 0$$

$\therefore (3x^2 - 5)$ divides $f(x)$.

$$f(x) = (3x^2 - 5)(x^2 - 5x + 6)$$

$$= (\sqrt{3}x + \sqrt{5})(\sqrt{3}x - \sqrt{5})(x - 2)(x - 3)$$

$$f(x) = 0,$$

$$\begin{array}{r}
 \overline{x^2 - 5x + 6} \\
 3x^2 - 5 \overline{) 3x^4 - 15x^3 + 13x^2 + 25x - 30} \\
 \underline{3x^4 - 5x^2} \\
 (-) (+) \\
 -15x^3 + 18x^2 + 25x - 30 \\
 \underline{-15x^3 + 25x} \\
 (+) (-) \\
 +18x^2 - 30 \\
 \underline{+18x^2 - 30} \\
 (-) (+) \\
 \hline
 0
 \end{array}$$

$$\Rightarrow (\sqrt{3}x + \sqrt{5}) = 0, \quad (\sqrt{3}x - \sqrt{5}) = 0, \quad (x - 2) = 0, \quad (x - 3) = 0$$

$$\therefore \text{zeros are } x = \sqrt{\frac{5}{3}}, \quad x = -\sqrt{\frac{5}{3}}, \quad x = 2, \quad x = 3.$$

48) If 3 and -3 are the zeros of the polynomial $x^4 + 2x^3 - 8x^2 - 18x - 9$, find all the zeros of the polynomial .

49) If the polynomial $x^3 - 3x^2 + x + 2$ is divided by $g(x)$, then the remainder is $-2x + 4$ and quotient is $x - 2$ Find the divisor $g(x)$.

Solution :- $p(x) = x^3 - 3x^2 + x + 2$, $q(x) = x - 2$ and $r(x) = -2x + 4$

$$p(x) - r(x) = (x^3 - 3x^2 + x + 2) - (-2x + 4)$$

$$p(x) - r(x) = x^3 - 3x^2 + x + 2 + 2x - 4$$

$$p(x) - r(x) = x^3 - 3x^2 + 3x - 2$$

$$g(x) = \frac{p(x) - r(x)}{q(x)}$$

$$g(x) = \frac{x^3 - 3x^2 + 3x - 2}{x - 2}$$

$$\therefore g(x) = x^2 - x + 1$$

$$\begin{array}{r} \overline{) x^3 - 3x^2 + 3x - 2} \\ \underline{x^3 - 2x^2} \\ -x^2 + 3x - 2 \\ \underline{-x^2 + 2x} \\ x - 2 \\ \underline{x - 2} \\ 0 \end{array}$$

UNIT – 10: Quadratic Equations

1 Mark Questions (MCQ)

- Which of the following is a quadratic equation?
 A) $x^2 + x^3 = 2$ B) $p(p - 3) = 0$ C) $x^2 = 6 + x^2 - x$ D) $x^2 + \frac{1}{x} = 5$
- If $x^2 + 1 = 101$ then the value of x is
 A) ± 1 B) ± 10 C) ± 11 D) $\pm \sqrt{10}$
- The value of discriminant of the quadratic equation $2x^2 - 5x - 1 = 0$ is
 A) 33 B) 3 C) 0 D) 35
- The discriminant of the quadratic equation $ax^2 + bx + c = 0$ is
 A) $b^2 - ac$ B) $b^2 - 4ac$ C) $\sqrt{b^2 - 4ac}$ D) $b^2 + 4ac$
- In the quadratic equation $ax^2 + bx + c = 0$, if $\frac{b^2}{4} = ac$ then the roots of the equation are
 A) Equal B) Distinct C) Additive inverse D) Reciprocals.
- In the quadratic equation $ax^2 + bx + c = 0$, if $a = c$ then the roots are
 A) Even numbers B) Odd numbers C) Negative numbers D) Reciprocals

- 7) The roots of equations $x^2 = 49$ are
 A) 7 and -7 B) 24 and 5 C) 8 and -8 D) 7 and 0
- 8) The roots of equations $x^2 - 4 = 0$ are
 A) 2 and 0 B) 2 and -2 C) 4 and 5 D) 1 and -1
- 9) The roots of equations $x^2 - 4x = 0$ are
 A) 0 and 2 B) -4 and 0 C) -2 and 0 D) 0 and 4

1 Mark Questions(VSA)

- 10) If the roots of equation $ax^2 + bx + c = 0$ are real and equal, what is the value of the discriminant ?
- 11) If $143 = t^2 - 1$ then solve for t .
- 12) Write the general form of a quadratic equation.

Ans	1) B	2) B	3) A	4) B	5) A	6) D	7) A	8) B
	9) D	10) $b^2 - 4ac = 0$		11) ± 12		12) $ax^2 + bx + c = 0$ ($a \neq 0$)		

2 Marks Questions (SA)

- 13) Verify if $x^2 - 2x = (-2)(3 - x)$ is a quadratic equation .
- 14) Find the roots of the equation $2x^2 - x + \frac{1}{8} = 0$ by factorization method

Solution :- $2x^2 - x + \frac{1}{8} = 0$

$16x^2 - 8x + 1 = 0$ (Multiplying each term by 8)

$16x^2 - 4x - 4x + 1 = 0$

$4x(4x - 1) - 1(4x - 1) = 0$

$(4x - 1)(4x - 1) = 0$

$4x - 1 = 0$, or $4x - 1 = 0$

$4x = 1$ or $4x = 1$

\therefore Roots $x = \frac{1}{4}$ or $x = \frac{1}{4}$

First term = $+16x^2$, Last term = $+1$
 Product = $16x^2 = -4x \times -4x$
 Middle term = $-8x = -4x - 4x$

- 15) Find the roots of the following quadratic equations by factor method.
 (i) $6x^2 - 11x - 10 = 0$ (ii) $2x^2 + x - 6 = 0$ (iii) $100x^2 - 20x + 1 = 0$
- 16) Solve the quadratic equation $2x^2 - 5x + 2 = 0$ by completing the square .

Solution :- $2x^2 - 5x + 2 = 0$ this is in the form $ax^2 + bx + c = 0$.

$a = 2$, $b = -5$, $c = 2$

$\left(x + \frac{b}{2a}\right)^2 = \left(\frac{b}{2a}\right)^2 - \frac{c}{a}$

$\left(x + \frac{-5}{2(2)}\right)^2 = \left(\frac{-5}{2(2)}\right)^2 - \frac{2}{2}$

$$\left(x - \frac{5}{4}\right)^2 = \frac{25}{16} - 1$$

$$\left(x - \frac{5}{4}\right)^2 = \frac{9}{16} \text{ (Taking square root on both side)}$$

$$x - \frac{5}{4} = \pm \frac{3}{4}$$

$$x = \pm \frac{3}{4} + \frac{5}{4}$$

$$x = +\frac{3}{4} + \frac{5}{4} \quad \text{or} \quad x = -\frac{3}{4} + \frac{5}{4}$$

$$x = \frac{8}{4} \quad \text{or} \quad x = \frac{2}{4}$$

$$x = 2 \quad \text{or} \quad x = \frac{1}{2}$$

17) Solve the following equations by completing the square.

(i) $5x^2 - 6x - 2 = 0$ (ii) $9x^2 - 15x + 6 = 0$ (iii) $2x^2 - 5x + 3 = 0$

18) Solve $4x^2 + 4\sqrt{3}x + 3 = 0$ by using formula.

Solution: - $4x^2 + 4\sqrt{3}x + 3 = 0$ this is in the form $ax^2 + bx + c = 0$.

$$a = 4, \quad b = 4\sqrt{3}, \quad c = 3$$

$$\text{Roots } x = \frac{-b \pm \sqrt{b^2 - 4ac}}{2a}$$

$$x = \frac{-(4\sqrt{3}) \pm \sqrt{(4\sqrt{3})^2 - 4(4)(3)}}{2(4)}$$

$$x = \frac{-4\sqrt{3} \pm \sqrt{16 \times 3 - 48}}{8}$$

$$x = \frac{-4\sqrt{3} \pm \sqrt{48 - 48}}{8}$$

$$x = \frac{-4\sqrt{3} \pm 0}{8}$$

$$x = \frac{-4\sqrt{3}}{8} \quad \text{OR} \quad x = \frac{-4\sqrt{3}}{8}$$

$$x = \frac{-\sqrt{3}}{2} \quad \text{OR} \quad x = \frac{-\sqrt{3}}{2}$$

19) Find the roots of the following equations by formula method.

(i) $2x^2 + x - 4 = 0$ (ii) $2x^2 - 7x + 3 = 0$ (iii) $2x^2 - 5x + 2 = 0$

(iv) $x^2 + 2x - 15 = 0$ (v) $x^2 - 11x + 30 = 0$ (vi) $x^2 - 2x = 8$

(vii) $x^2 - 7x + 12 = 0$ (viii) $x^2 - 4 = 3x$ (ix) $2x^2 - 2\sqrt{2}x = -1$

20) Show that the equation, $3x^2 - 4\sqrt{3}x + 4 = 0$ has real and equal roots.

Solution :- $3x^2 - 4\sqrt{3}x + 4 = 0$

$a = 3, \quad b = -4\sqrt{3}, \quad c = 4$

Discriminant = $b^2 - 4ac$

= $(-4\sqrt{3})^2 - 4(3)(4)$

= $48 - 48$

= 0

$\therefore b^2 - 4ac = 0$

\Rightarrow The equation has real and equal roots.

21) Find the discriminant of the equation $3x^2 - 2x + \frac{1}{3} = 0$. From this find the nature of the roots. Find the roots if they are real.

Solution:- $3x^2 - 2x + \frac{1}{3} = 0 \quad a = 3, \quad b = -2, \quad c = \frac{1}{3}$

Discriminant = $b^2 - 4ac$

= $(-2)^2 - 4(3)\left(\frac{1}{3}\right)$

= $4 - 4 = 0$

$\therefore b^2 - 4ac = 0$

\Rightarrow The equation has two equal real roots.

\therefore the roots are $\frac{-b}{2a} = \frac{-(-2)}{2(3)}$ and $\frac{-b}{2a} = \frac{-(-2)}{2(3)}$

The roots are $\frac{2}{2(3)}$ and $\frac{2}{2(3)}$

\therefore The roots are $\frac{1}{3}$ and $\frac{1}{3}$.

22) Discuss the nature of the roots of the equation, $2x^2 - 3x + 5 = 0$.

23) Discuss the nature of the roots of the equation, $x^2 - 6x + 3 = 0$.

24) Find the value of k so that the roots of the equation $2x^2 + kx + 3 = 0$ are equal.

Solution : $2x^2 + kx + 3 = 0 \quad a = 2, \quad b = k, \quad c = 3$

For equal roots, $b^2 - 4ac = 0$

$(k)^2 - 4(2)(3) = 0$

$k^2 - 24 = 0$

$k^2 = 24$

$\sqrt{k^2} = \sqrt{4 \times 6} = \pm 2\sqrt{6}$

25) Find the value of k so that the roots of the equation $kx(x - 2) + 6 = 0$ are equal.

26) A rectangular mango grove whose length is twice its breadth, and it's area is 800m^2 . find it's length and breadth.

Solution :- Let breadth of a rectangular mango grove = x m

Length = $2x$ m

Area of Rectangular mango grove = length \times breadth

$$(2x)(x) = 800$$

$$2x^2 = 800$$

$$x^2 = \frac{800}{2} = 400$$

$$x = \pm\sqrt{400} = \pm 20$$

Breadth of mango grove = $x = 20$ m

length of mango grove = $2x = 2 \times 20 = 40$ m

- 27) **The base of a rectangle is $(x + 5)$ cm and its height is $(x - 5)$ cm. If the area of the rectangle is 56cm^2 , Find its dimensions.**

Solution: base $b = (x + 5)$ cm and height $h = (x - 5)$ cm.

Area of the rectangle = 56cm^2

$$(x + 5)(x - 5) = 56 \quad (\because \text{Area of the rectangle} = \text{base} \times \text{height})$$

$$x^2 - 5^2 = 56 \quad \text{or} \quad (\text{length} \times \text{breadth})$$

$$x^2 - 25 = 56$$

$$x^2 = 56 + 25$$

$$x^2 = 81$$

$$x^2 = 9^2 \quad \therefore x = 9$$

$$b = (x + 5) = 9 + 5 = 14\text{cm}$$

$$h = (x - 5) = 9 - 5 = 4\text{cm}$$

3 or 4 Marks Questions (LA-1 / LA-2)

- 28) **The present age of Kavya and Karthik is 11 and 14 years respectively. After how many years the product of their ages will become 304?**

Solution: The present age of Kavya = 11 years

The present age of Karthik = 14 years

After x years Kavya's age = $(11 + x)$ years

After x years Karthik's age = $(14 + x)$ years

After x years the product of their Ages = 304

$$(11 + x)(14 + x) = 304$$

$$11 \times 14 + 11x + 14x + x^2 = 304$$

$$154 + 25x + x^2 - 304 = 0$$

$$x^2 + 25x - 150 = 0$$

$$x^2 + 30x - 5x - 150 = 0$$

$$(x^2 + 30x) - (5x + 150) = 0$$

$$x(x + 30) - 5(x + 30) = 0$$

$$x + 30 = 0 \quad \text{or} \quad x - 5 = 0$$

$$\therefore x = -30 \quad \text{or} \quad x = 5$$

After 5 years the product of their ages will become 304.

$$30 \times 5 = 150$$

$$30 - 5 = 25$$

- 29) Some children participated in a birthday party. In that birthday party each child gives 2 gifts to every other child. If the total number of gifts is 264, find the number of children in that birthday party.

Solution: Let x be the number of children participated in that birthday party.

Each child gives 2 gifts to $(x - 1)$ children.

x children gives 2 gifts to $(x - 1)$ children.

Total Number of gifts = $x \times 2 \times (x - 1)$

$$x \times 2 \times (x - 1) = 264$$

$$2x^2 - 2x - 264 = 0$$

$$x^2 - x - 132 = 0 \text{ (Divide each term by 2)}$$

$$x^2 - 12x + 11x - 132 = 0$$

$$(x^2 - 12x) + (11x - 132) = 0$$

$$x(x - 12) + 11(x - 12) = 0$$

$$x - 12 = 0 \text{ or } x + 11 = 0$$

$$\therefore x = 12 \text{ or } x = -11$$

\therefore 12 children participated in that birthday party.

$$12 \times 11 = 132$$

$$-12 + 11 = -1$$

- 30) An express train takes 1 hour less than the passenger train to travel 132 km between Bengaluru and Mysuru. If the average speed of the express train is 11km/h more than that of the passenger train, what is the average speed of the two trains?

Solution : average speed of passenger train = x km/h

Average speed of express train = $(x + 11)$ km/h

Total distance travelled = 132 km

$$\text{Time taken by passenger train} = \frac{132}{x} \text{ h}$$

$$\text{Time taken by express train} = \frac{132}{x+11} \text{ h}$$

Time difference between these two journeys = 1 h

$$\therefore \frac{132}{x} - \frac{132}{x+11} = 1$$

$$132(x + 11) - 132x = x(x + 11)$$

$$132x + 1452 - 132x = x^2 + 11x$$

$$x^2 + 11x - 1452 = 0$$

$$x^2 + 44x - 33x - 1452 = 0$$

$$x(x + 44) - 33(x + 44) = 0$$

$$(x + 44)(x - 33) = 0$$

$$x + 44 = 0, \quad x - 33 = 0$$

$$x = -44, \quad x = 33$$

Average speed of passenger train = 33 km/h

Average speed of express train = $(33 + 11) = 44$ km/h

$$44 \times 33 = 1452$$

$$44 - 33 = 11$$

- 31) A motor boat whose speed is 18 km/h in still water takes 1 hour more to go 24 km upstream than to return downstream to the same spot. Determine the speed of the stream.

Solution : Let the speed of the stream = x km/h

Speed of a motor boat in still water = 18 km/h

Then, the speed of the boat upstream = $(18 - x)$ km/h

The speed of the boat downstream = $(18 + x)$ km/h

Total distance travelled = 24 km

Time taken to go upstream = $\frac{24}{18 - x}$ h

Time taken to go downstream = $\frac{24}{18 + x}$ h

Time difference between these two journeys = 1 h

$$\therefore \frac{24}{18 - x} - \frac{24}{18 + x} = 1$$

$$\frac{24(18 + x) - 24(18 - x)}{(18 + x)(18 - x)} = 1$$

$$\frac{24 \times 18 + 24x - 24 \times 18 + 24x}{18^2 - x^2} = 1$$

$$\frac{48x}{18^2 - x^2} = 1$$

$$48x = 18^2 - x^2$$

$$x^2 + 48x - 324 = 0$$

$$x^2 + 54x - 6x - 324 = 0$$

$$x(x + 54) - 6(x + 54) = 0$$

$$(x + 54)(x - 6) = 0$$

$$x = -54 \text{ or } x = 6$$

\therefore the speed of the stream is 6 km/h.

$$324 \times 1 = 324$$

$$324 = 54 \times 6$$

$$54 - 6 = 48$$

- 32) Ravi buys a number of books for Rs 60. If he had bought 5 more books for the same amount, each book would have cost him Re 1 less. How many books did he buy? Find the price of each book.
- 33) A train travels a distance of 300 km at a uniform speed. If the speed of the train is increased by 10 km an hour, the journey would have taken 1 hour less. Find the original speed of the train.
- 34) Two water taps together can fill a tank in $9\frac{3}{8}$ hour. The tap of larger diameter taken 10 hour less than the smaller one to fill the tank separately. Find the time in which each tap can separately fill the tank.
- 35) The difference of squares of two numbers is 180. The square of the smaller number is 8 times the larger number. Find the two numbers.
- 36) A merchant sells an article for Rs 24 and gains as much per cent as the cost price of the article. Find the cost price of the article.

- 37) Shwetha takes 6 days less than the time taken by Ankitha to finish a piece of work. If both Shwetha and Ankitha together can finish it in 4 days, Find the time taken by Ankitha to finish the work.
- 38) A merchant sells an article for Rs 18.75 and loses as much per cent as the cost price of the article. Find the cost price of the article.
- 39) **Find the length and breadth of a rectangular park whose perimeter is 100m and its area is 600 m².**

Solution:- let l and b are the length and breadth of a rectangular park

$$\text{Perimeter} = 2(l + b) = 100$$

$$l + b = \frac{100}{2} = 50$$

$$b = 50 - l$$

$$\text{Area of the park } l \times b = 600$$

$$l(50 - l) = 600$$

$$50l - l^2 = 600$$

$$l^2 - 50l + 600 = 0$$

$$l^2 - 30l - 20l + 600 = 0$$

$$l(l - 30) - 20(l - 30) = 0$$

$$(l - 30)(l - 20) = 0$$

$$l = 30 \text{ or } l = 20$$

$$\text{Length } l = 30 \text{ m}$$

$$\text{Breadth } b = 50 - l = 50 - 30 = 20 \text{ m}$$

$$600 \times 1 = 600$$

$$600 = 30 \times 20$$

$$-30 - 20 = -50$$

- 40) The diagonal of a rectangular field is 60 meter more than the shorter side. If the longer side is 30 meters more than the shorter side, find the sides of the field.
- 41) The height of a triangle is 6 cm more than its base. If the area of the triangle is 108cm², find the length of the base and height of the triangle.
- 42) **If the roots of the equation $(a - b)x^2 + (b - c)x + (c - a) = 0$ are equal, prove that $b + c = 2a$.**

Solution: compare $(a - b)x^2 + (b - c)x + (c - a) = 0$ with $ax^2 + bx + c = 0$.

$$a = (a - b), \quad b = (b - c), \quad c = (c - a)$$

$$\text{Since roots are equal, } b^2 - 4ac = 0$$

$$(b - c)^2 - 4(a - b)(c - a) = 0$$

$$b^2 + c^2 - 2bc - 4(ca - a^2 - bc + ab) = 0$$

$$b^2 + c^2 - 2bc - 4ca + 4a^2 + 4bc - 4ab = 0$$

$$4a^2 + b^2 + c^2 - 4ab + 2bc - 4ca = 0$$

$$(-2a)^2 + b^2 + c^2 + 2(-2a)b + 2bc + 2c(-2a) = 0$$

$$(-2a + b + c)^2 = 0$$

$$-2a + b + c = 0$$

$$\therefore b + c = 2a$$

- 43) If the equation $(1 + m^2)x^2 + 2mcx + (c^2 - a^2) = 0$ has equal roots, prove that $c^2 = a^2(1 + m^2)$.

Solution: compare $(1 + m^2)x^2 + 2mcx + (c^2 - a^2) = 0$ with $ax^2 + bx + c = 0$.
 $a = (1 + m^2)$, $b = 2mc$, $c = (c^2 - a^2)$

Since roots are equal, $b^2 - 4ac = 0$

$$(2mc)^2 - 4(1 + m^2)(c^2 - a^2) = 0$$

$$4m^2c^2 - 4(c^2 - a^2 + m^2c^2 - m^2a^2) = 0$$

$$4m^2c^2 - 4c^2 + 4a^2 - 4m^2c^2 + 4m^2a^2 = 0$$

$$4a^2(1 + m^2) = 4c^2$$

$$a^2(1 + m^2) = c^2$$

$$\therefore c^2 = a^2(1 + m^2)$$

- 44) If the roots of the equation $(c^2 - ab)x^2 - 2(a^2 - bc)x + (b^2 - ac) = 0$ are real and equal, prove that either $a = 0$ or $a^3 + b^3 + c^3 = 3abc$.

Solution: compare $(c^2 - ab)x^2 - 2(a^2 - bc)x + (b^2 - ac) = 0$ with $ax^2 + bx + c = 0$,
 $a = (c^2 - ab)$, $b = -2(a^2 - bc)$, $c = (b^2 - ac)$

Since roots are real and equal, $b^2 - 4ac = 0$

$$(-2(a^2 - bc))^2 - 4(c^2 - ab)(b^2 - ac) = 0$$

$$4(a^2 - bc)^2 - 4(c^2 - ab)(b^2 - ac) = 0$$

$$(a^2 - bc)^2 - (c^2 - ab)(b^2 - ac) = 0$$

$$a^4 + b^2c^2 - 2a^2bc - b^2c^2 + ac^3 + ab^3 - a^2bc = 0$$

$$a^4 + ab^3 + ac^3 - 3a^2bc = 0$$

$$a(a^3 + b^3 + c^3 - 3abc) = 0$$

$$\Rightarrow a = 0 \text{ or } a^3 + b^3 + c^3 - 3abc = 0$$

$$\therefore a = 0 \text{ or } a^3 + b^3 + c^3 = 3abc$$

5 Marks Questions (LA - 3)

- 45) In the adjoining figure, ABCD is a rhombus. The diagonals AC and BD intersect at Point E. If $BE = x + 7$, $AE = x$ and $AB = x + 8$, find the length of AC and BD.

Solution: $AE = x$, $BE = x + 7$ and $AB = x + 8$

From the $\triangle AEB$

$$AB^2 = AE^2 + BE^2 \quad (\because \text{Pythagoras theorem})$$

$$(x + 8)^2 = (x)^2 + (x + 7)^2$$

$$x^2 + 2(x)(8) + 8^2 = x^2 + [x^2 + 2(x)(7) + 7^2]$$

$$x^2 + 16x + 64 = x^2 + x^2 + 14x + 49$$

$$0 = x^2 + 14x - 16x + 49 - 64$$

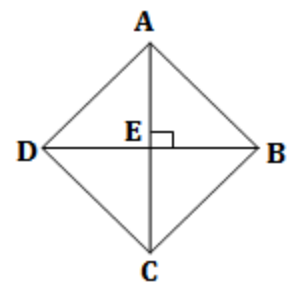

$$x^2 - 2x - 15 = 0$$

$$x^2 - 5x + 3x - 15 = 0$$

$$(x^2 - 5x) + (3x - 15) = 0$$

$$x(x - 5) + 3(x - 5) = 0$$

$$x - 5 = 0 \quad \text{or} \quad x + 3 = 0$$

$$\therefore x = 5 \quad \text{or} \quad x = -3$$

$$\therefore AE = CE = x = 5 \quad (\because \text{The diagonals bisect each other})$$

$$\text{diagonal } AC = AE + CE = 5 + 5 = 10$$

$$\therefore BE = x + 7 = 5 + 7 = 12$$

$$\therefore DE = BE = 12 \quad (\because \text{The diagonals bisect each other})$$

$$\text{diagonal } BD = DE + BE = 12 + 12 = 24$$

$$\therefore AC = 10 \text{ units and } BD = 24 \text{ units.}$$

$$\left| \begin{array}{l} 5 \times 3 = 15 \\ -5 + 3 = -2 \end{array} \right.$$

UNIT- 11 : INTRODUCTION TO TRIGONOMETRY

1 Mark Questions (MCQ)

- 1) If $\tan A = \frac{4}{3}$ then the value of $4 \cot A$ is
 A) $\frac{1}{3}$ B) $\frac{3}{4}$ C) 4 D) 3
- 2) If $\cos \theta = \frac{12}{13}$ then the value of $\sec \theta$ is
 A) $\frac{13}{12}$ B) $\frac{12}{25}$ C) $\frac{5}{13}$ D) $\frac{5}{12}$
- 3) If $\sin A = \frac{4}{5}$ then the value of $\operatorname{cosec} A$ is
 A) $\frac{4}{5}$ B) $\frac{5}{4}$ C) $\frac{3}{4}$ D) $\frac{3}{5}$
- 4) If $\sqrt{3} \tan A = 1$ then the value of $\angle A$ is
 A) 60° B) 30° C) 45° D) 90°
- 5) The value of $\tan^2 60^\circ$ is
 A) $\sqrt{3}$ B) $\frac{1}{3}$ C) 3 D) $\frac{1}{\sqrt{3}}$
- 6) The value of $\operatorname{cosec}^2 45^\circ$ is
 A) 2 B) $\sqrt{2}$ C) $\frac{1}{2}$ D) $\frac{1}{\sqrt{2}}$
- 7) The value of $1 + \tan^2 45^\circ$ is
 A) 0 B) 2 C) 3 D) $\sqrt{2}$
- 8) The value of $1 - \tan^2 45^\circ$ is
 A) 0 B) 2 C) 3 D) $\sqrt{2}$

- 9) The value of $\frac{\tan 65^\circ}{\cot 25^\circ}$ is
 A) $\sqrt{2}$ B) 0 C) 1 D) $\frac{1}{\sqrt{2}}$
- 10) The value of $\cos 48^\circ - \sin 42^\circ$ is
 A) $\frac{1}{2}$ B) 0 C) 1 D) $\frac{3}{2}$
- 11) If $\sin 2A = 2\sin A$ is true when $A = ?$
 A) 0° B) 30° C) 45° D) 60°
- 12) The value $9 \sec^2 A - 9 \tan^2 A$ is
 A) 0 B) 1 C) 8 D) 9
- 13) The equal value of $\cos A$ is
 A) $\frac{1}{\operatorname{cosec} A}$ B) $\frac{1}{\sec A}$ C) $\frac{1}{\sin A}$ D) $\frac{1}{\cot A}$
- 14) $(\sin A + \cos A)^2$ is equal to
 A) $\sin^2 A + \cos^2 A$ B) $1 - 2 \sin A \cdot \cos A$
 C) $\sin^2 A - \cos^2 A$ D) $1 + 2 \sin A \cdot \cos A$

1 Mark Questions (VSA)

- 15) If $\sin x = \frac{3}{5}$ then find the value of $3 \operatorname{cosec} x$.
- 16) If $\cot \theta = \frac{7}{8}$ then find the value of $\cot^2 \theta$.
- 17) If $2 \cos \theta = 1$ then find the value of acute angle θ .
- 18) If $\sqrt{3} \cot A = 1$ then find the value of acute angle A .
- 19) Find the value of $\frac{\sin 18^\circ}{\cos 72^\circ}$
- 20) Find the value of $\operatorname{cosec} 31^\circ - \sec 59^\circ$.
- 21) Find the value of $\sin^2 75^\circ + \cos^2 75^\circ$.
- 22) Find the value of $\frac{\sin \theta}{\cos (90^\circ - \theta)} + \frac{\cos \theta}{\sin (90^\circ - \theta)}$
- 23) If $\tan x = 3 \cot x$, find the value of $\tan^2 x$.

Ans	1) D	2) A	3) B	4) B	5) C	6) A	7) B
8)A	9) C	10) B	11) A	12) D	13) B	14) D	15) 5
16) $\frac{49}{64}$	17) 60°	18) 60°	19) 1	20) 0	21) 1	22) 2	23) 3

2 Marks Questions (SA)

- 24) In $\triangle ABC$, find $\sin A$ and $\cos A$ if $\angle B = 90^\circ$, $AB = 24\text{cm}$ and $BC = 7\text{cm}$.

Solution : In $\triangle ABC$, $\angle B = 90^\circ$

given that $AB = 24\text{cm}$, $BC = 7\text{cm}$

$AC^2 = AB^2 + BC^2$ (\because Pythagoras theorem)

$$AC^2 = 576 + 49$$

$$AC^2 = 625$$

$$AC = 25$$

$$AC = 25\text{cm}$$

$$\sin A = \frac{\text{opp}}{\text{hyp}} = \frac{7}{25}$$

$$\cos A = \frac{\text{adj}}{\text{hyp}} = \frac{24}{25}$$

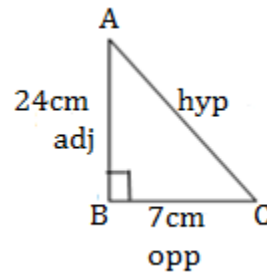

- 25) If $\cot \theta = \frac{7}{8}$ find other 5 trigonometric ratios.
- 26) If $\sin A = \frac{3}{4}$ find other 5 trigonometric ratios.
- 27) If $\sec \theta = \frac{13}{12}$ find other 5 trigonometric ratios.
- 28) If $15 \cot A = 8$, find $\sin A$ and $\sec A$.
- 29) If $2 \cos \theta = 1$ find other 5 trigonometric ratios.
- 30) If $2 \sin \theta = \sqrt{3}$ find other 5 trigonometric ratios.
- 31) If $3 \tan A = \sqrt{3}$ find $\sin 3A$ and $\cos 2A$.

Solution : $3 \tan A = \sqrt{3}$

$$\tan A = \frac{\sqrt{3}}{3}$$

$$\tan A = \frac{\sqrt{3}}{\sqrt{3} \times \sqrt{3}}$$

$$\tan A = \frac{1}{\sqrt{3}}$$

$$\Rightarrow A = 30^\circ$$

$$\sin 3A = \sin 3(30^\circ) = \sin 90^\circ = 1$$

$$\cos 2A = \cos 2(30^\circ) = \cos 60^\circ = \frac{1}{2}$$

- 32) If $13 \sin A = 5$, A is an acute angle find $\frac{5 \sin A - 2 \cos A}{\tan A}$.
- 33) If $A = 60^\circ$, $B = 30^\circ$ then prove $\cos(A + B) = \cos A \cdot \cos B - \sin A \cdot \sin B$.
- 34) If $A = 60^\circ$, $B = 30^\circ$ then prove that $\tan(A - B) = \frac{\tan A - \tan B}{1 + \tan A \cdot \tan B}$.

35) If $B = 15^\circ$, then prove that $4\sin 2B \cdot \cos 4B \cdot \sin 6B = 1$.

36) Prove that $2\cos^2\theta - 1 = \cos^2\theta - \sin^2\theta$.

3 Marks Questions (LA-1)

37) Show that $\frac{1-\cos\theta}{1+\cos\theta} = (\operatorname{cosec}\theta - \cot\theta)^2$.

$$\begin{aligned} \text{Solution : LHS} &= \frac{(1-\cos\theta)}{(1+\cos\theta)} \\ &= \frac{(1-\cos\theta)(1-\cos\theta)}{(1+\cos\theta)(1-\cos\theta)} \quad [\text{Multiply numerator and denominator by } (1-\cos\theta).] \\ &= \frac{(1-\cos\theta)^2}{1-\cos^2\theta} \quad [\because 1 - \cos^2\theta = (1 + \cos\theta)(1 - \cos\theta)] \\ &= \frac{1^2 + \cos^2\theta - 2(1)(\cos\theta)}{\sin^2\theta} \quad [\because \sin^2\theta = 1 - \cos^2\theta] \\ &= \frac{1}{\sin^2\theta} + \frac{\cos^2\theta}{\sin^2\theta} - \frac{2\cos\theta}{\sin^2\theta} \\ &= \frac{1}{\sin^2\theta} + \frac{\cos^2\theta}{\sin^2\theta} - \frac{2}{\sin\theta} \cdot \frac{\cos\theta}{\sin\theta} \quad [\because \frac{\cos^2\theta}{\sin^2\theta} = \cot^2\theta] \\ &= \operatorname{cosec}^2\theta + \cot^2\theta - 2 \cdot \operatorname{cosec}\theta \cdot \cot\theta \quad [\because \frac{1}{\sin^2\theta} = \operatorname{cosec}^2\theta] \\ &= (\operatorname{cosec}\theta - \cot\theta)^2 \\ &= \text{RHS} \end{aligned}$$

38) Prove that $\sqrt{\sec^2\theta + \operatorname{cosec}^2\theta} = (\tan\theta + \cot\theta)$.

$$\begin{aligned} \text{Solution : LHS} &= \sqrt{\sec^2\theta + \operatorname{cosec}^2\theta} \\ &= \sqrt{(1 + \tan^2\theta) + (1 + \cot^2\theta)} \quad [\because 1 + \tan^2\theta = \sec^2\theta, 1 + \cot^2\theta = \operatorname{cosec}^2\theta] \\ &= \sqrt{\tan^2\theta + \cot^2\theta + 2} \\ &= \sqrt{\tan^2\theta + \cot^2\theta + 2\tan\theta \cdot \cot\theta} \quad [\because \tan\theta \cdot \cot\theta = 1] \\ &= \sqrt{(\tan\theta + \cot\theta)^2} \\ &= (\tan\theta + \cot\theta) = \text{RHS} \end{aligned}$$

39) Prove that $\frac{\tan^2\theta}{1+\tan^2\theta} + \frac{\cot^2\theta}{1+\cot^2\theta} = 1$.

$$\text{Solution : LHS} = \frac{\tan^2\theta}{1+\tan^2\theta} + \frac{\cot^2\theta}{1+\cot^2\theta}$$

$$\begin{aligned}
&= \frac{\tan^2\theta}{\sec^2\theta} + \frac{\cot^2\theta}{\operatorname{cosec}^2\theta} \quad [\because 1 + \tan^2\theta = \sec^2\theta, \quad 1 + \cot^2\theta = \operatorname{cosec}^2\theta] \\
&= \frac{\sin^2\theta}{\cos^2\theta} \cdot \frac{1}{\sec^2\theta} + \frac{\cos^2\theta}{\sin^2\theta} \cdot \frac{1}{\operatorname{cosec}^2\theta} \\
&= \frac{\sin^2\theta}{\cos^2\theta} \cdot \cos^2\theta + \frac{\cos^2\theta}{\sin^2\theta} \cdot \sin^2\theta \quad [\because \frac{1}{\sec^2\theta} = \cos^2\theta, \quad \frac{1}{\operatorname{cosec}^2\theta} = \sin^2\theta] \\
&= \sin^2\theta + \cos^2\theta \\
&= 1 = \text{RHS}
\end{aligned}$$

40) Prove that $\frac{\sec\theta + \tan\theta}{\sec\theta - \tan\theta} = 1 + 2\tan^2\theta + 2\sec\theta \cdot \tan\theta$

$$\begin{aligned}
\text{Solution : LHS} &= \frac{\sec\theta + \tan\theta}{\sec\theta - \tan\theta} \\
&= \frac{\sec\theta + \tan\theta}{\sec\theta - \tan\theta} \times \frac{\sec\theta + \tan\theta}{\sec\theta + \tan\theta} \quad [\text{Multiply numerator and denominator by } \sec\theta + \tan\theta] \\
&= \frac{(\sec\theta + \tan\theta)^2}{\sec^2\theta - \tan^2\theta} \\
&= \frac{\sec^2\theta + \tan^2\theta + 2\sec\theta \cdot \tan\theta}{1 + \tan^2\theta - \tan^2\theta} \\
&= 1 + \tan^2\theta + \tan^2\theta + 2\sec\theta \cdot \tan\theta \quad [\because 1 + \tan^2\theta = \sec^2\theta] \\
&= 1 + 2\tan^2\theta + 2\sec\theta \cdot \tan\theta = \text{RHS}
\end{aligned}$$

41) Prove that $\operatorname{cosec}^4 A - \operatorname{cosec}^2 A = \cot^4 A + \cot^2 A$.

$$\begin{aligned}
\text{Solution: LHS} &= \operatorname{cosec}^4 A - \operatorname{cosec}^2 A \\
&= \operatorname{cosec}^2 A (\operatorname{cosec}^2 A - 1) \\
&= (1 + \cot^2 A) (1 + \cot^2 A - 1) \quad (\because \operatorname{cosec}^2 A = 1 + \cot^2 A) \\
&= (1 + \cot^2 A) (\cot^2 A) \\
&= (\cot^2 A + \cot^4 A) \\
&= (\cot^4 A + \cot^2 A) = \text{RHS}
\end{aligned}$$

42) If $\pi = 180^\circ$ and $A = \frac{\pi}{6}$, then prove that $\frac{(1+\cos A)(1-\cos A)}{(1-\sin A)(1+\sin A)} = \frac{1}{3}$.

43) If $\tan(A + B) = \sqrt{3}$ and $\tan(A - B) = \frac{1}{\sqrt{3}}$. Here $0^\circ < (A + B) \leq 90^\circ$;
Then find the value A and B.

44) Prove that $\frac{\sin\theta}{1+\cos\theta} + \frac{1+\cos\theta}{\sin\theta} = 2\operatorname{cosec}\theta$.

45) Prove that $(1 + \cot\theta - \operatorname{cosec}\theta)(1 + \tan\theta + \sec\theta) = 2$.

4 Marks Questions (LA-2)

46) Prove that $\frac{\cos(90^\circ - \theta)}{1 + \cos\theta} + \frac{\sin\theta}{1 - \sin(90^\circ - \theta)} = 2\operatorname{cosec}\theta$.

$$\begin{aligned} \text{Solution: LHS} &= \frac{\cos(90^\circ - \theta)}{1 + \cos\theta} + \frac{\sin\theta}{1 - \sin(90^\circ - \theta)} \\ &= \frac{\sin\theta}{1 + \cos\theta} + \frac{\sin\theta}{1 - \cos\theta} \quad [\because \cos(90^\circ - \theta) = \sin\theta, \quad \sin(90^\circ - \theta) = \cos\theta] \\ &= \frac{(1 - \cos\theta)\sin\theta + (1 + \cos\theta)\sin\theta}{(1 + \cos\theta)(1 - \cos\theta)} \\ &= \frac{\sin\theta - \cos\theta\sin\theta + \sin\theta + \cos\theta\sin\theta}{(1 + \cos\theta)(1 - \cos\theta)} \\ &= \frac{2\sin\theta}{1 - \cos^2\theta} \\ &= \frac{2\sin\theta}{\sin^2\theta} \quad [\because 1 - \cos^2\theta = \sin^2\theta] \\ &= \frac{2}{\sin\theta} \\ &= 2\operatorname{cosec}\theta = \text{RHS} \quad [\because \frac{1}{\sin\theta} = \operatorname{cosec}\theta] \end{aligned}$$

47) Prove that $\frac{\sin(90^\circ - \theta)}{1 + \sin\theta} + \frac{\cos\theta}{1 - \cos(90^\circ - \theta)} = 2\sec\theta$.

48) Prove that $\frac{\cos(90^\circ - \theta)}{1 + \sin(90^\circ - \theta)} + \frac{1 + \sin(90^\circ - \theta)}{\cos(90^\circ - \theta)} = 2\operatorname{cosec}\theta$.

49) Prove that $\sin^6 A + \cos^6 A = 1 - 3\sin^2 A \cos^2 A$.

$$\begin{aligned} \text{Solution: LHS} &= \sin^6 A + \cos^6 A \\ &= (\sin^2 A)^3 + (\cos^2 A)^3 \quad [a^3 + b^3 = (a + b)(a^2 + b^2 - ab)] \\ &= (\sin^2 A + \cos^2 A)[(\sin^2 A)^2 + (\cos^2 A)^2 - \sin^2 A \cdot \cos^2 A] \\ &= (1)[(\sin^2 A)^2 + (\cos^2 A)^2 + 2\sin^2 A \cdot \cos^2 A - 2\sin^2 A \cdot \cos^2 A - \sin^2 A \cdot \cos^2 A] \\ &= [(\sin^2 A + \cos^2 A)^2 - 3\sin^2 A \cdot \cos^2 A] \quad (\because \sin^2 A + \cos^2 A = 1) \\ &= [(1)^2 - 3\sin^2 A \cdot \cos^2 A] \\ &= 1 - 3\sin^2 A \cdot \cos^2 A = \text{RHS} \end{aligned}$$

5 Marks Questions (LA-3)

50) if $\cos\theta + \sin\theta = \sqrt{2}\cos\theta$, prove that $\cos\theta - \sin\theta = \sqrt{2}\sin\theta$.

$$\text{Solution: } \cos\theta + \sin\theta = \sqrt{2}\cos\theta \text{ ----->(1)}$$

$$(\cos\theta + \sin\theta)^2 = (\sqrt{2}\cos\theta)^2 \quad (\because \text{squaring on both sides.})$$

$$\cos^2 \theta + \sin^2 \theta + 2 \cos \theta \cdot \sin \theta = 2 \cos^2 \theta$$

$$2 \cos \theta \cdot \sin \theta = 2 \cos^2 \theta - \cos^2 \theta - \sin^2 \theta$$

$$2 \cos \theta \cdot \sin \theta = \cos^2 \theta - \sin^2 \theta$$

$$\cos^2 \theta - \sin^2 \theta = 2 \cos \theta \cdot \sin \theta$$

$$(\cos \theta + \sin \theta)(\cos \theta - \sin \theta) = 2 \cos \theta \cdot \sin \theta$$

$$\sqrt{2} \cos \theta (\cos \theta - \sin \theta) = 2 \cos \theta \cdot \sin \theta \quad [\because \text{From (1)}]$$

$$(\cos \theta - \sin \theta) = \frac{2 \cos \theta \cdot \sin \theta}{\sqrt{2} \cos \theta}$$

$$(\cos \theta - \sin \theta) = \frac{2 \sin \theta}{\sqrt{2}}$$

$$(\cos \theta - \sin \theta) = \frac{2 \times \sqrt{2} \sin \theta}{\sqrt{2} \times \sqrt{2}}$$

$$(\cos \theta - \sin \theta) = \frac{2 \times \sqrt{2} \sin \theta}{2}$$

$$\therefore (\cos \theta - \sin \theta) = \sqrt{2} \sin \theta$$

51) Prove that $\frac{\sin \theta}{1 - \cos \theta} + \frac{\tan \theta}{1 + \cos \theta} = \sec \theta \operatorname{cosec} \theta + \cot \theta$.

52) Prove that $\frac{\tan \theta + \sec \theta - 1}{\tan \theta - \sec \theta + 1} = \frac{1 + \sin \theta}{\cos \theta}$.

53) Prove that $\frac{\tan A}{1 - \cot A} + \frac{\cot A}{1 - \tan A} = 1 + \tan A + \cot A = 1 + \sec A \operatorname{cosec} A$.

54) Prove that $\frac{\tan \theta - \cot \theta}{\sin \theta \cos \theta} = \sec^2 \theta - \operatorname{cosec}^2 \theta = \tan^2 \theta - \cot^2 \theta$.

UNIT – 12 : SOME APPLICATIONS OF TRIGONOMETRY

1 Mark Questions (VSA)

1) Find the value of x in the following figures.

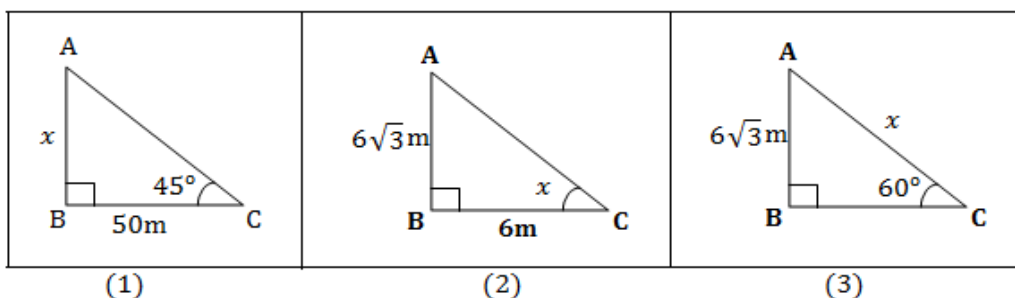

Ans	1) 50m	2) 60°	3) 12m
-----	--------	--------	--------

2 / 3 Marks Questions (SA/LA-1)

- 2) Find the value of the unknown in the following figure.

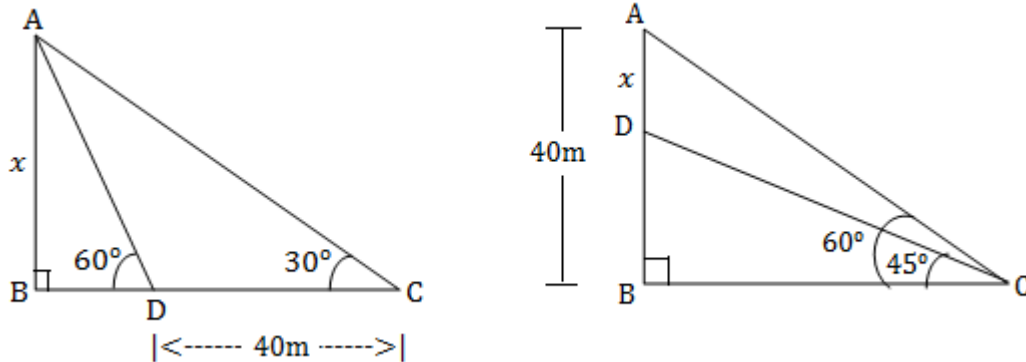

- 3) The angle of elevation of ladder leaning against a wall is 60° and the foot of a ladder is 9.5 m away from the wall. find the length of ladder .

Solution : Here AB = length of the wall

BC = distance from wall to foot of ladder

AC = length of ladder

$$\cos\theta = \frac{\text{adj}}{\text{hyp}} = \frac{9.5}{AC}$$

$$\cos 60^\circ = \frac{9.5}{AC}$$

$$\frac{1}{2} = \frac{9.5}{AC}$$

$$AC = 9.5 \times 2 = 19 \quad \therefore \text{Length of ladder} = 19\text{m}$$

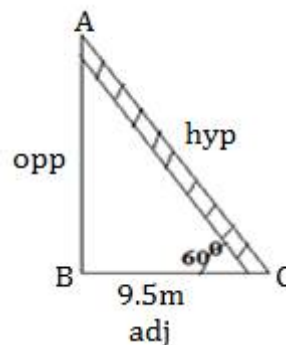

4 Marks Questions (LA-2)

- 4) The angles of elevation of the top of a tower from two points on the ground at a distance a metres and b metres ($a > b$) from the base of the tower and in the same straight line are complementary. Prove that the height of the tower $h = \sqrt{ab}$ metres.

Solution: The height of a tower $h = ?$

According to data, let $\angle D = \theta$ and $\angle C = 90^\circ - \theta$.

$BD = a$ m. and $BC = b$ m.

From the ΔABD ,

$$\tan \theta = \frac{\text{opp}}{\text{adj}} = \frac{AB}{BD} = \frac{h}{a} \quad \text{-----} > (1)$$

From the ΔABC ,

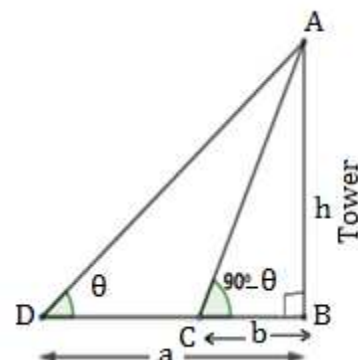

$$\cot(90^\circ - \theta) = \frac{\text{adj}}{\text{opp}} = \frac{BC}{AB} = \frac{b}{h}$$

$$\tan \theta = \frac{b}{h} \quad \text{-----} \rightarrow (2) \quad [\because \cot(90^\circ - \theta) = \tan \theta]$$

Equating (1) and (2)

$$\frac{h}{a} = \frac{b}{h}$$

$$h^2 = ab$$

$$h = \sqrt{ab} \text{ m.}$$

- 5) Two wind mills of height 50 m and 40 m are on either side of the field. A person observes the top of the wind mills from a point on the ground in between the towers. The angle of elevation was found to be 45° in both the cases, find the distance between the wind mills.
- 6) A tower stands vertically on the ground from a point on the ground which is 50m away from the foot of the tower the angle of elevation to top of the tower is 60° , find the height of the tower?
- 7) A tree is broken over by the wind forms a right angle triangle with the ground. If the broken part makes an angle of 60° with ground and the top of the tree is now 20 m from its base. How tall was the tree?
- 8) From the top of a building 16m high. The angular elevation of the top of a hill is 60° and the angular depression of the foot of the hill is 30° . Find the height of the hill.

UNIT – 13 : STATISTICS

1 Mark Questions (MCQ)

- 1) In the following which is not a measure of central tendency?
 A) Mode B) Range C) Median D) Mean
- 2) The relationship between the measures of central tendency
 A) Median = Mode + 2 Mean B) Mode = 3 Median - 2 Mean
 C) 3Median = 2 Mode + 2 Mean D) Mode = 3 Median + 2 Mean
- 3) The x- co ordinate of the point of intersection of two ogives, which were drawn as "more than" type and "less than" type for same data, represents
 A) Mean. B) Median
 C) Mode. D) Cumulative frequency.
- 4) The midpoint of the CI 10 - 25 is
 A) 35 B) 15 C) 17.5 D) -7.5

- 5) Calculate mode, if mean and median of some scores is 58 and 50 respectively.
 A) 34 B) 43 C) 108 D) 8
- 6) The point of intersection of two ogives, which were drawn as “more than” type and “less than” type for the some data is (66.4, 26.5). The Median of the same data is
 A) 26.5 B) 39.9 C) 66.4 D) 33.2

1 Mark Questions (VSA)

- 7) Calculate median for the given scores 1, 5, 4, 3, 2.
- 8) What is the other name of cumulative frequency curve?
- 9) Write the formula to find mean for grouped data.
- 10) Calculate median for the given scores 2, 8, 10, 6, 12, 16.

	1) B	2) B	3) B	4) C	5) A
Ans	6) C	7) 3	8) Ogive	9) $\bar{x} = \frac{\sum f_i x_i}{\sum f_i}$	10) 9

3 Marks Questions (LA-1)

- 11) Find the Mean of the following data.

CI	10 - 25	25 - 40	40 - 55	55 - 70	70 - 85	85 - 100
f	2	3	7	6	6	6

Solution: Direct method

CI	f_i	Mid point x_i	$f_i x_i$
10 - 25	2	17.5	35.0
25 - 40	3	32.5	97.5
40 - 55	7	47.5	332.5
55 - 70	6	62.5	375.0
70 - 85	6	77.5	465.0
85 - 100	6	92.5	555.0
	$\sum f_i = 30$		$\sum f_i x_i = 1860.0$

$$\text{Mean } \bar{x} = \frac{\sum f_i x_i}{\sum f_i}$$

$$\text{Mean } \bar{x} = \frac{1860}{30}$$

$$\text{Mean } \bar{x} = 62$$

Solution: Assumed mean method

Assumed Mean **a = 17.5**

<i>CI</i>	f_i	Mid point x_i	$d_i = x_i - a$	$f_i d_i$
10 - 25	2	17.5	0	0
25 - 40	3	32.5	15	45
40 - 55	7	47.5	30	210
55 - 70	6	62.5	45	270
70 - 85	6	77.5	60	360
85 - 100	6	92.5	75	450
	$\Sigma f_i = 30$			$\Sigma f_i d_i = 1335$

$$\text{Mean } \bar{x} = a + \frac{\Sigma f_i d_i}{\Sigma f_i}$$

$$\text{Mean } \bar{x} = 17.5 + \frac{1335}{30}$$

$$\text{Mean } \bar{x} = 17.5 + 44.5$$

$$\text{Mean } \bar{x} = 62$$

Solution: Step deviation method

Assumed Mean **a = 17.5** ,

size of calss interval **h = 15**

<i>CI</i>	f_i	Mid point x_i	$u_i = \frac{x_i - a}{h}$	$f_i u_i$
10 - 25	2	17.5	0	0
25 - 40	3	32.5	1	3
40 - 55	7	47.5	2	14
55 - 70	6	62.5	3	18
70 - 85	6	77.5	4	24
85 - 100	6	92.5	5	30
	$\Sigma f_i = 30$			$\Sigma f_i u_i = 89$

$$\text{Mean } \bar{x} = a + \left[\frac{\sum f_i u_i}{\sum f_i} \right] \times h$$

$$\text{Mean } \bar{x} = 17.5 + \left[\frac{89}{30} \right] \times 15$$

$$\text{Mean } \bar{x} = 17.5 + \frac{89}{2}$$

$$\text{Mean } \bar{x} = 17.5 + 44.5$$

$$\text{Mean } \bar{x} = 62$$

12) Find the Mean of the following data.

<i>CI</i>	15 - 25	25 - 35	35 - 45	45 - 55	55 - 65	65 - 75	75 - 85
<i>f_i</i>	6	11	7	4	4	2	1

13) Find the Mode of the following data.

<i>CI</i>	5 - 15	15 - 25	25 - 35	35 - 45	45 - 55	55 - 65
<i>f_i</i>	6	11	21	23	14	5

Solution:

<i>CI</i>	<i>f_i</i>
5 - 15	6
15 - 25	11
25 - 35	21 <i>f₀</i>
35 - 45	23 <i>f₁</i>
45 - 55	14 <i>f₂</i>
55 - 65	5
	<i>n = 80</i>

Maximum frequency = 23

Modal class = 35 - 45

Lower limit of modal class ***l = 35***

Class size ***h = 10***

Frequency of the Modal class ***f₁ = 23***

Frequency of the class preceeding the Modal class

f₀ = 21

Frequency of the class succeeding the Modal class

f₂ = 14

$$\text{Mode} = l + \left[\frac{f_1 - f_0}{2f_1 - f_0 - f_2} \right] \times h$$

$$\text{Mode} = 35 + \left[\frac{23 - 21}{2 \times 23 - 21 - 14} \right] \times 10$$

$$\text{Mode} = 35 + \left[\frac{2}{46 - 35} \right] \times 10$$

$$\text{Mode} = 35 + \frac{20}{11}$$

$$\text{Mode} = 35 + 1.82 \quad \therefore \text{Mode} = 36.82$$

14) Find the Mode of the following data.

<i>CI</i>	0 - 10	10 - 20	20 - 30	30 - 40	40 - 50	50 - 60	60 - 70	70 - 80
<i>f</i>	7	12	13	14	20	15	11	8

15) Find the Mode of the following data.

<i>CI</i>	15 - 20	20 - 25	25 - 30	30 - 35	35 - 40	40 - 45	45 - 50	50 - 55
<i>f</i>	3	8	9	10	3	0	0	2

16) Find the Mode of the following data.

<i>CI</i>	1 - 3	3 - 5	5 - 7	7 - 9	9 - 11
<i>f</i>	7	8	2	2	1

17) Find the Mode of the following data.

<i>CI</i>	0 - 20	20 - 40	40 - 60	60 - 80	80 - 100	100 - 120
<i>f</i>	10	35	52	61	38	29

18) Find the Median of the following data.

<i>CI</i>	0 - 20	20 - 40	40 - 60	60 - 80	80 - 100	100 - 120	120 - 140
<i>f</i>	6	8	10	12	6	5	3

Solution:

<i>CI</i>	<i>f</i>	<i>Cf</i>
0 - 20	6	6
20 - 40	8	14
40 - 60	10	24 <i>cf</i>
60 - 80	12 <i>f</i>	36
80 - 100	6	42
100 - 120	5	47
120 - 140	3	50
	<i>n</i> = 50	

$$\text{Median } \frac{n}{2} = \frac{50}{2} = 25^{\text{th}} \text{ value.}$$

Median class = 60 - 80

Lower limit of Median class ***l* = 60**

Number of observation ***n* = 50**

$$\frac{n}{2} = \frac{50}{2} = 25$$

Cumulative frequency of class

preceeding the median class ***cf* = 24**

Frequency of median class ***f* = 12**

Class size ***h* = 20**

$$\text{Median} = l + \left[\frac{\frac{n}{2} - cf}{f} \right] \times h$$

$$\text{Median} = 60 + \left[\frac{25 - 24}{12} \right] \times 20$$

$$\text{Median} = 60 + \left[\frac{1}{3} \right] \times 5$$

$$\text{Median} = 60 + \frac{5}{3}$$

$$\text{Median} = 60 + 1.67$$

$$\text{Median} = 61.67$$

19) Find the Median of the following data.

<i>CI</i>	50 - 55	55 - 60	60 - 65	65 - 70	70 - 75	75 - 80
<i>f</i>	2	8	12	24	38	16

20) Find the Median of the following data.

<i>CI</i>	15 - 25	25 - 35	35 - 45	45 - 55	55 - 65	65 - 75	75 - 85
<i>f</i>	6	11	7	4	4	2	1

21) Find the Median of the following data.

<i>CI</i>	100 - 120	120 - 140	140 - 160	160 - 180	180 - 200
<i>f</i>	12	14	8	6	10

22) Find the Median of the following data.

<i>CI</i>	135 - 140	140 - 145	145 - 150	150 - 155	155 - 160	160 - 165
<i>f</i>	4	7	18	11	6	5

23) Find the Median of the following data.

<i>CI</i>	<i>f</i>
5 - 10	2
10 - 15	12
15 - 20	2
20 - 25	4
25 - 30	3
30 - 35	4
35 - 40	3

<i>CI</i>	<i>f</i>
0 - 10	12
10 - 20	16
20 - 30	6
30 - 40	7
40 - 50	9
	n = 50

24) During the medical check-up of 35 students of a class, their weights are recorded as follows. Draw a less than type ogive for the given data. Hence obtain the median weight from the graph.

Weight (in kg)	Number of students
Less than 38	0
Less than 40	3
Less than 42	5
Less than 44	9
Less than 46	14
Less than 48	28
Less than 50	32
Less than 52	35

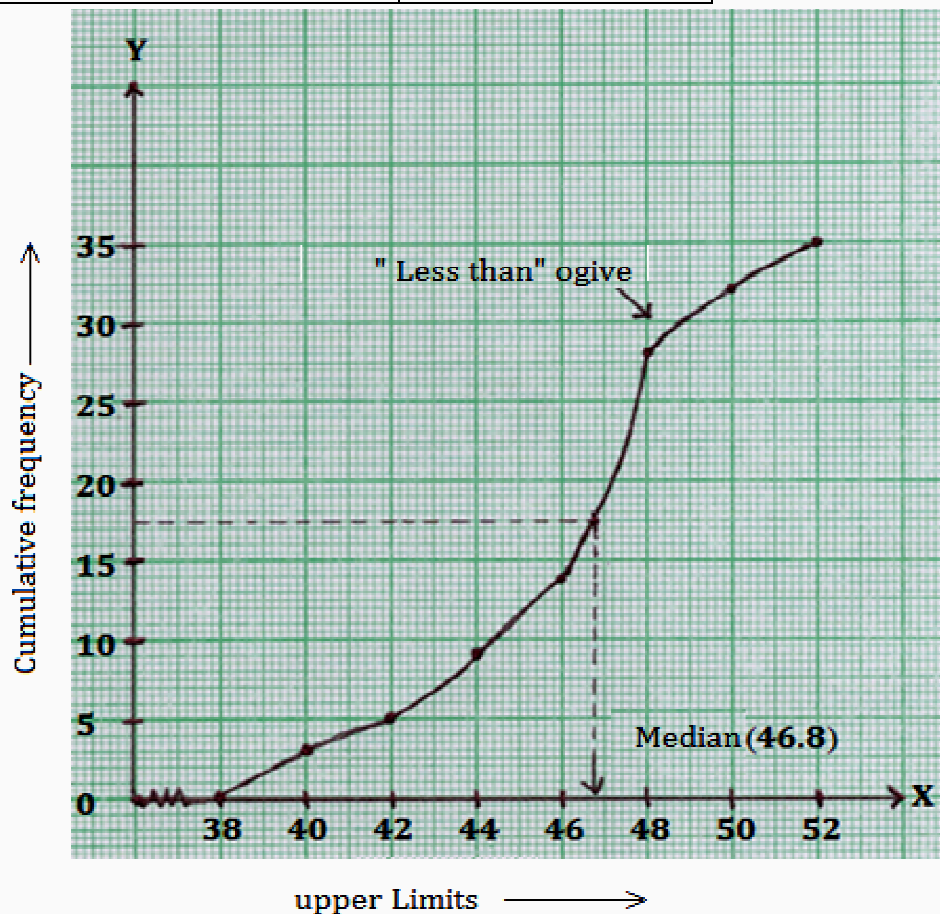

25) Change the following distribution to a less than type distribution, and draw its ogive.

CI	0 - 3	3 - 6	6 - 9	9 - 12	12 - 15
f	9	3	5	3	1

Solution:

CI	f	Cumulative frequency (cf)
Less than 3	9	9
Less than 6	3	12
Less than 9	5	17
Less than 12	3	20
Less than 15	1	21

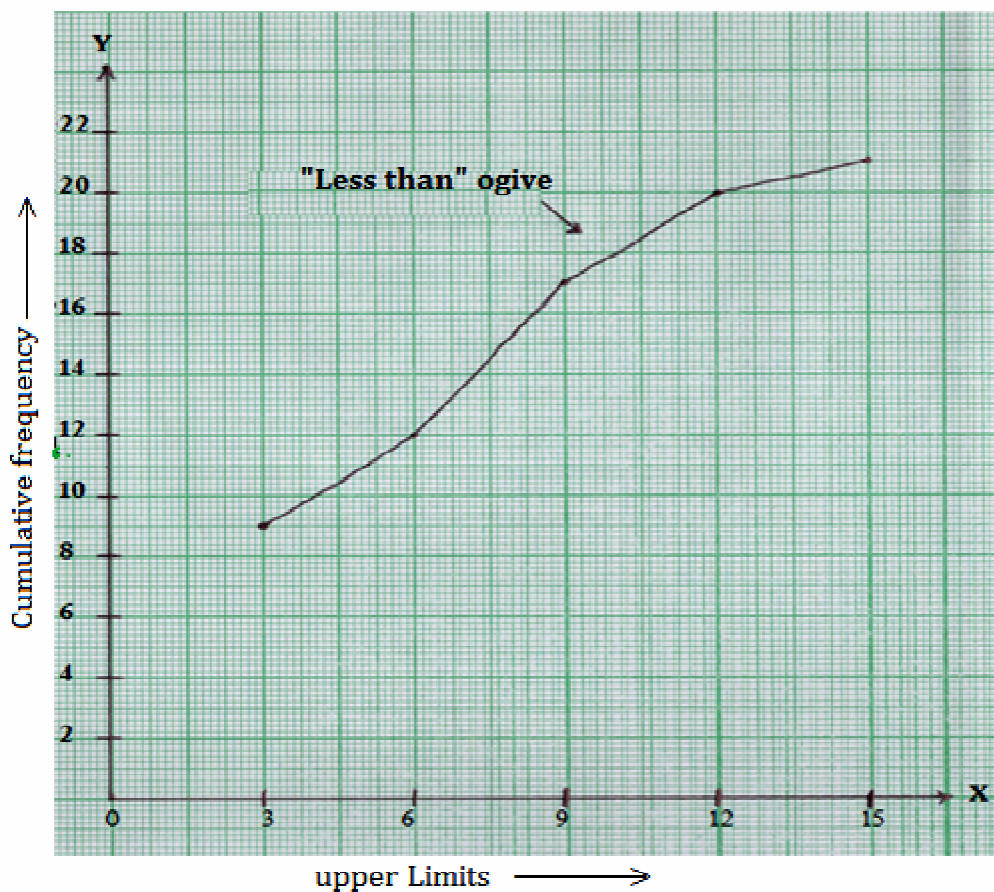

26) Change the following distribution to a less than type distribution, and draw its ogive.

CI	100- 120	120 - 140	140 - 160	160 - 180	180 - 200
f	12	14	8	6	10

27) Change the following distribution to a more than type distribution, and draw its ogive.

CI	0 - 3	3 - 6	6 - 9	9 - 12	12 - 15
f	9	3	5	3	1

Solution:

CI	f	Cumulative frequency (cf)
More than or equal to 0	9	21
More than or equal to 3	3	12
More than or equal to 6	5	9
More than or equal to 9	3	4
More than or equal to 12	1	1

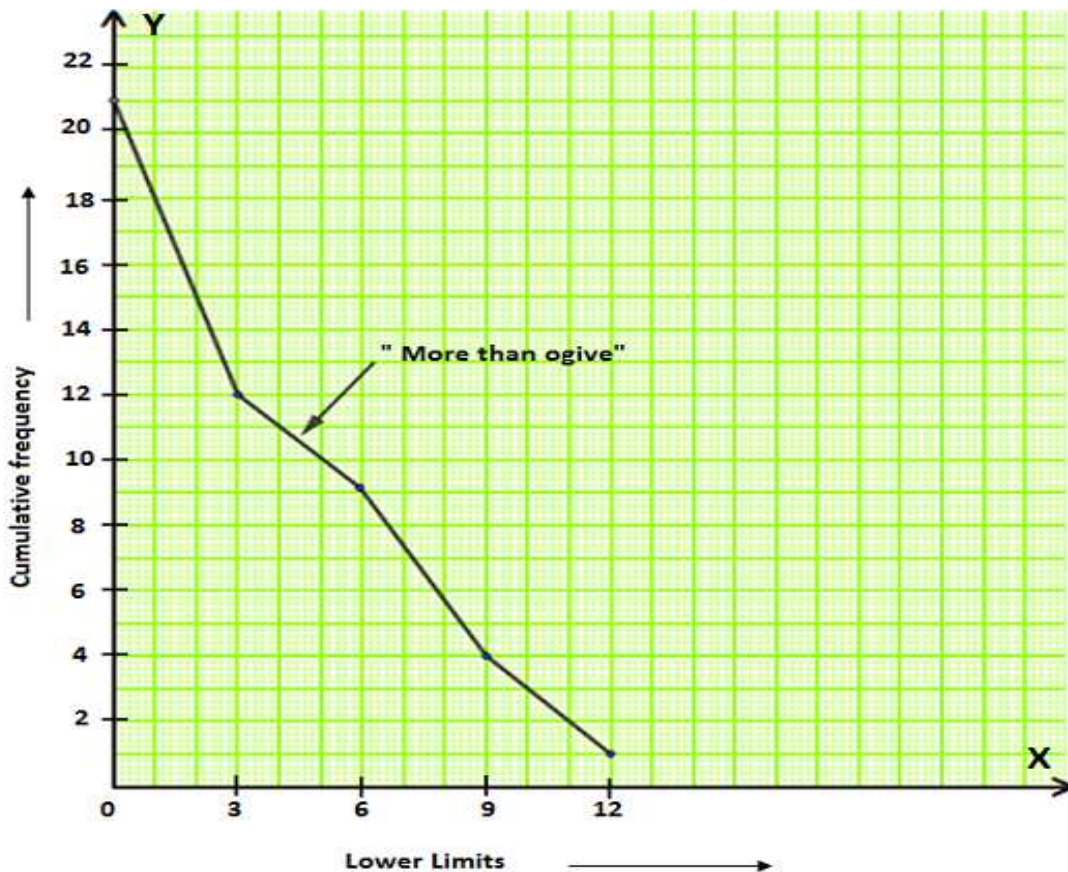

28) Change the following distribution to a more than type distribution, and draw its ogive.

CI	50- 55	55 - 60	60 - 65	65 - 70	70 - 75	75 - 80
f	2	8	12	24	38	16

4Marks Questions (LA-2)

- 29) The following table shows a "less than" type distribution. Find the Mode of the distribution. If the median of the distribution is 56.43, calculate its Mean.

<i>CI</i>	Cumulative frequency (<i>Cf</i>)
Less than 20	8
Less than 40	15
Less than 60	29
Less than 80	38
Less than 100	53

Solution: Median = 56.43

<i>CI</i>	<i>f_i</i>
Less than 20	8
20 - 40	7 <i>f₀</i>
<i>l</i> 40 - 60	14 <i>f₁</i>
60 - 80	9 <i>f₂</i>
80 - 100	15

Maximum frequency = 14

Modal class = 40 - 60

Lower limit of modal class *l* = 40

Class size *h* = 20

Frequency of the Modal class *f₁* = 14

Frequency of the class preceding the

Modal class *f₀* = 7

Frequency of the class succeeding the

Modal class *f₂* = 9

$$\text{Mode} = l + \left[\frac{f_1 - f_0}{2f_1 - f_0 - f_2} \right] \times h$$

$$\text{Mode} = 40 + \left[\frac{14 - 7}{2(14) - 7 - 9} \right] \times 20$$

$$\text{Mode} = 40 + \left[\frac{7}{28 - 16} \right] \times 20$$

$$\text{Mode} = 40 + \left[\frac{7}{12} \right] \times 20$$

$$\text{Mode} = 40 + \left[\frac{7}{3} \right] \times 5$$

$$\text{Mode} = 40 + \frac{35}{3}$$

$$\text{Mode} = 40 + 11.67$$

$$\text{Mode} = 51.67$$

$$\text{Mode} = 3 \text{ Median} - 2 \text{ Mean}$$

$$51.67 = 3 \times 56.43 - 2 \text{ Mean}$$

$$2 \text{ Mean} = 169.29 - 51.67$$

$$\text{Mean} = \frac{117.62}{2} = 58.81$$

- 30) The following table gives the marks scored by the 50 students of a class in a Examination. If the arithmetic mean of the distribution is 25.2, find the missing frequencies p and q .

Marks	0 - 10	10 - 20	20 - 30	30 - 40	40 - 50
Number of students	8	p	10	11	q

Solution: Arithmetic mean $\bar{x} = 25.2$ and $\sum f_i = 50$

CI	f_i	Mid point x_i	$f_i x_i$
0 - 10	8	5	40
10 - 20	p	15	$5p$
20 - 30	10	25	250
30 - 40	11	35	385
40 - 50	q	45	$45q$
	$\sum f_i = 50$		$\sum f_i x_i = 675 + 5p + 45q$

$$p + q = 50 - (8 + 10 + 11)$$

$$p + q = 50 - 29$$

$$p + q = 21$$

$$p = 21 - q \text{ -----} > (1)$$

$$\bar{x} = \frac{\sum f_i x_i}{\sum f_i}$$

$$25.2 = \frac{675 + 5p + 45q}{50}$$

$$1260.0 = 675 + 5p + 45q$$

$$1260 - 675 = 5(p + 9q)$$

$$\frac{585}{5} = (p + 9q)$$

$$p + 9q = 117$$

$$21 - q + 9q = 117 \text{ [}\because \text{ From (1)]}$$

$$8q = 117 - 21$$

$$8q = 96$$

$$\therefore q = 12$$

$$p = 21 - 12 \text{ [}\because \text{ substituting for } q \text{ in (1)]}$$

$$\therefore p = 9$$

31) The median of the following distribution is 28.5, find the values of x and y .

Class interval	0 - 10	10 - 20	20 - 30	30 - 40	40 - 50	50 - 60	Total
frequency	5	x	20	15	y	5	60

solution: Median = 28.5

CI	f	cf
0- 10	5	5
10 - 20	x	$5 + x$
20 - 30	20	$25 + x$
30 - 40	15	$40 + x$
40 - 50	y	$40 + x + y$
50 - 60	5	$45 + x + y$
	$n = 60$	

Median class = 20 - 30

Lower limit of Median class $l = 20$

Number of observation $n = 60$

$$\frac{n}{2} = \frac{60}{2} = 30$$

Cumulative frequency of class preceding the median class $cf = 5 + x$

Frequency of median class $f = 20$

Class size $h = 10$

From the table $45 + x + y = 60$

$$x + y = 60 - 45$$

$$x + y = 15 \text{ -----}>(1)$$

$$\text{Median} = l + \left[\frac{\frac{n}{2} - cf}{f} \right] \times h$$

$$28.5 = 20 + \left[\frac{30 - 5 - x}{20} \right] \times 10$$

$$28.5 - 20 = \left[\frac{25 - x}{2} \right]$$

$$8.5 \times 2 = 25 - x$$

$$17 = 25 - x$$

$$x = 25 - 17$$

$$\therefore x = 8$$

$$x + y = 15$$

$$8 + y = 15 \text{ } [\because \text{substituting for } x \text{ in (1)}]$$

$$y = 15 - 8$$

$$\therefore y = 7$$

32) If the Mode of the following distribution is 36, Find the value of x .

Marks	0 - 10	10 - 20	20 - 30	30 - 40	40 - 50	50 - 60	60 - 70
Number of students	8	10	x	16	12	6	7

Solution: Mode = 36

CI	f_i
0 - 10	8
10 - 20	10
20 - 30	$x \quad f_0$
$l \quad 30 - 40$	16 f_1
40 - 50	12 f_2
50 - 60	6
60 - 70	7

Mode = **36** (given)

\therefore Modal class = 30 - 40

Lower limit of modal class $l = 30$

Class size $h = 10$

Frequency of the Modal class $f_1 = 16$

Frequency of the class preceding the

Modal class $f_0 = x$

$$\text{Mode} = l + \left[\frac{f_1 - f_0}{2f_1 - f_0 - f_2} \right] \times h$$

$$36 = 30 + \left[\frac{16 - x}{2 \times 16 - x - 12} \right] \times 10$$

$$36 - 30 = \left[\frac{16 - x}{20 - x} \right] \times 10$$

$$\frac{6}{10} = \left[\frac{16 - x}{20 - x} \right]$$

$$\frac{3}{5} = \left[\frac{16 - x}{20 - x} \right] \quad \begin{array}{c} \times \\ \swarrow \searrow \\ \downarrow \end{array}$$

$$80 - 5x = 60 - 3x$$

$$80 - 60 = 5x - 3x$$

$$20 = 2x$$

$$\therefore x = 10$$

5 Marks Questions (LA-3)

- 33) The following table shows a "more than" type distribution. Find the Median of the distribution. If the Arithmetic mean of the distribution is 69.3, calculate its Mode.

Marks scored	Number of students
More than or equal to 50	100
More than or equal to 55	98
More than or equal to 60	90
More than or equal to 65	78
More than or equal to 70	54
More than or equal to 75	16

Solution: Arithmetic mean = 69.3

<i>CI</i>	<i>f</i>	<i>Cf</i>
50- 55	2	2
55 - 60	8	10
60 - 65	12	22
65 - 70	24	46 cf
70 - 75	38 f	84
75 - 80	16	100
	<i>n</i> = 100	

$$\text{Median } \frac{n}{2} = \frac{100}{2} = 50^{\text{th}} \text{ value.}$$

$$\text{Median class} = 70 - 75$$

$$\text{Lower limit of Median class } l = 70$$

$$\text{Number of observation } n = 100$$

$$\frac{n}{2} = \frac{100}{2} = 50$$

Cumulative frequency of class preceeding the median class $cf = 46$

$$\text{Frequency of median class } f = 38$$

$$\text{Class size } h = 5$$

$$\text{Median} = l + \left[\frac{\frac{n}{2} - cf}{f} \right] \times h$$

$$\text{Median} = 70 + \left[\frac{50 - 46}{38} \right] \times 5$$

$$\text{Median} = 70 + \left[\frac{4}{38} \right] \times 5$$

$$\text{Median} = 70 + \frac{20}{38}$$

$$\text{Median} = 70 + \frac{10}{19}$$

$$\text{Median} = 70 + 0.5$$

$$\text{Median} = 70.5$$

$$\text{Mode} = 3 \text{ Median} - 2 \text{ Mean}$$

$$\text{Mode} = 3 \times 70.5 - 2 \times 69.3$$

$$\text{Mode} = 211.5 - 138.6$$

$$\text{Mode} = 72.9$$

UNIT – 14: PROBABILITY

1 Mark Questions (MCQ)

- 1) Which of the following is the probability of an event?
 A) $\frac{3}{2}$ B) - 1.5 C) 15% D) -0.7
- 2) If $P(E) = 0.05$, what is the probability of 'not E'?
 A) 0.05 B) 0.95 C) 0.005 D) 1.05
- 3) The probability of winning a game is $\frac{5}{6}$, then the probability of losing the game is
 A) $\frac{-5}{6}$ B) $\frac{5}{6}$ C) $\frac{-1}{6}$ D) $\frac{1}{6}$
- 4) If the probability of an event is 1, then the event is called
 A) Complementary event B) impossible event
 C) mutually exclusive event D) sure event
- 5) The probability of winning a game is 0.3, then the probability of losing the game is
 A) 0.1 B) 0.3 C) 0.7 D) 1.3
- 6) A die is thrown once, the probability of getting an odd number is .
 A) $\frac{1}{6}$ B) $\frac{4}{6}$ C) $\frac{2}{6}$ D) $\frac{3}{6}$ →
- 7) The probability of winning a game is **Lower limits of CI**, then the probability of losing the game is
 A) 40% B) 10% C) 60% D) 20%
- 8) A die is thrown once, the probability of getting a number less than 6 is
 A) $\frac{1}{6}$ B) $\frac{4}{6}$ C) $\frac{2}{6}$ D) $\frac{5}{6}$
- 9) Two fair coins are tossed once, the probability of getting head turns up is
 A) $\frac{1}{4}$ B) $\frac{2}{4}$ C) $\frac{3}{4}$ D) $\frac{-1}{4}$

1 Mark Questions (VSA)

- 10) The chance of raining in a particular day is 35% . then what is the chance of not raining on the same day ?
- 11) If E and \bar{E} both are complementary events, then the value of $P(E) + P(\bar{E})$ is?
- 12) In a random experiment, what is the total probability of all the primary events?
- 13) The probability of losing the game is $\frac{1}{4}$. Find the probability of winning the same game.
- 14) The probability of an event is 0. Name the type of event .

Ans	1) C	2) B	3) D	4) D	5) C	6) D	7) A	8) D	9) A
	10) 65%	11) 1	12) 1	13) $\frac{3}{4}$	14) Impossible Event				

2Marks Questions (SA)

- 15) A die is thrown once. what is the probability of getting a number less than or equal to 4

Solution: - $S = \{1, 2, 3, 4, 5, 6\} \therefore n(S) = 6$

Let E be the event getting a number less than equal to 4.

$$E = \{1, 2, 3, 4\} \quad \therefore n(E) = 4$$

$$P(E) = \frac{n(E)}{n(S)}$$

$$\therefore P(E) = \frac{4}{6} = \frac{2}{3}$$

- 16) A die is throw once. calculate the probability of getting

- | | |
|--------------------------------------|------------------------|
| i) a prime number | ii) an odd number |
| iii) a number lying between 2 and 6. | iv) a composite number |
| v) Even number | vi) a square number |

- 17) A box contains 50 discs which are numbered from 1 to 50. if one disc is drawn at random from the box, find the probability that it bears i) a perfect cube number
ii) a number which is divisible by 2 and 3 .

- 18) Two dice are thrown. what is the probability of getting, a) two identical faces
b) sum of two faces are equal to 8 .

Solution:- $S = \{(1, 1) (1, 2) (1, 3) (1, 4) (1, 5) (1, 6)$
 $(2, 1) (2, 2) (2, 3) (2, 4) (2, 5) (2, 6)$
 $(3, 1) (3, 2) (3, 3) (3, 4) (3, 5) (3, 6)$
 $(4, 1) (4, 2) (4, 3) (4, 4) (4, 5) (4, 6)$
 $(5, 1) (5, 2) (5, 3) (5, 4) (5, 5) (5, 6)$
 $(6, 1) (6, 2) (6, 3) (6, 4) (6, 5) (6, 6)\}$

Total outcomes $n(S) = 36$

- a) Let A be an event of getting two identical faces (Doublets)

$$A = \{(1, 1)(2, 2)(3, 3)(4, 4)(5, 5) (6, 6)\}$$

$$\therefore n(A) = 6$$

$$P(A) = \frac{n(A)}{n(S)}$$

$$P(A) = \frac{6}{36} = \frac{1}{6}$$

- b) Let B be an event of getting a sum 8 in two faces.

$$B = \{(2, 6), (3, 5), (4, 4), (5, 3), (6, 2)\}.$$

$$\therefore n(B) = 5$$

$$P(B) = \frac{n(B)}{n(S)}$$

$$P(B) = \frac{5}{36}$$

19) Two dice thrown simultaneously, find the probability of the following events.

- i) Difference between the numbers in two faces is 2
- ii) Sum between the numbers in two faces is 5
- iii) Product of the numbers in two faces is 12
- iv) Number except 5
- v) Product of the numbers as a perfect square number in two faces.
- vi) To get 5 at least once.

20) **Three coins are tossed together, find the probability of getting (i) at least 2 tail (ii) at most 2 tail**

Solution :- (i) three coins are tossed together, the outcomes = $n(S) = 8$

$$S = \{HHH, HHT, HTH, THH, HTT, THT, TTH, TTT\} \therefore n(S) = 8$$

Let A is event of getting at least 2 tails.

$$A = \{HTT, THT, TTH, TTT\} \therefore n(A) = 4$$

$$P(A) = \frac{n(A)}{n(S)}$$

$$\therefore P(A) = \frac{4}{8} = \frac{1}{2}$$

(ii) Let B is event of getting at most 2 tails.

$$B = \{HHH, HHT, HTH, THH, HTT, THT, TTH\} \therefore n(B) = 7$$

$$P(B) = \frac{n(B)}{n(S)}$$

$$\therefore P(B) = \frac{7}{8}$$

21) Three unbiased coins are tossed. Find the probability of getting

- (i) no tail
- (ii) at most one head.

22) There are three children in a family. Find the probability that there is one girl in the family.

23) **A box contains 500 wrist watches, in which 50 are damaged. One wrist watch is selected randomly from the box. Find the probability of getting a damaged wrist watch.**

Solution:- Total wrist watches = 500

$$\therefore n(S) = 500$$

Let 'A' be an event of getting a damaged wrist watch

$$\therefore n(A) = 50$$

$$P(A) = \frac{n(A)}{n(S)}$$

$$P(A) = \frac{50}{500} = \frac{1}{10}$$

- 24) A box contains 20 bulbs, in which 4 are damaged. One bulb is drawn out randomly from the box. Find the probability of getting (i) a damaged bulb (ii) a good bulb
- 25) From a bag containing 5 red, 8 white and 4 black marbles, one is drawn at random. Find the probability of getting,
- a red marble
 - a white marble
 - not a black marble.
- 26) A bag containing 5 red balls. If the probability of drawing a blue ball from the bag is thrice that of a red ball, find the number of blue balls in the bag.

Solution: Number of red balls = 5

Let the number of blue balls in the bag be x

Then, total number of balls = $(5 + x)$

The probability of drawing a red ball from the bag,

$$P(R) = \frac{n(R)}{n(S)}$$

$$\therefore P(R) = \frac{5}{5+x} \text{ -----}>(1)$$

The probability of drawing a blue ball from the bag,

$$P(B) = \frac{n(B)}{n(S)}$$

$$\therefore P(B) = \frac{x}{5+x} \text{ -----}>(2)$$

Given: $P(B) = 3 \times P(R)$

$$\frac{x}{5+x} = 3 \times \frac{5}{5+x}$$

$$\frac{x}{5+x} = \frac{15}{5+x}$$

$$\therefore x = 15$$

Hence, the number of blue balls in the bag is 15.

Note : In a random experiment of throwing two dice , to solve the problems related to addition the following table is very useful.

		Numbers on faces of 1 st die						
		+	1	2	3	4	5	6
Numbers on faces of the 2 nd die	1	2	3	4	5	6	7	
	2	3	4	5	6	7	8	
	3	4	5	6	7	8	9	
	4	5	6	7	8	9	10	
	5	6	7	8	9	10	11	
	6	7	8	9	10	11	12	

Example : Probability of getting a sum 8 in two faces $\frac{5}{36}$

Note : In a random experiment of throwing two dice , to solve the problems related to multiplication the following table is very useful.

		Numbers on faces of 1 st die						
		×	1	2	3	4	5	6
Numbers on faces of the 2 nd die	1	1	2	3	4	5	6	
	2	2	4	6	8	10	12	
	3	3	6	9	12	15	18	
	4	4	8	12	16	20	24	
	5	5	10	15	20	25	30	
	6	6	12	18	24	30	36	

Example : Probability of getting a Product 12 in two faces $\frac{4}{36} = \frac{1}{9}$

UNIT – 15: SURFACE AREAS AND VOLUMES**1 Mark Questions (MCQ)**

- 1) A solid has been melted and recast into a wire. Which of the following remains the same?
A) length B) height C) radius D) volume
- 2) The curved surface area of a frustum of the cone is
A) $\pi(r_1 + r_2)l$ B) $\pi(r_1 + r_2)h$ C) $\pi(r_1 - r_2)l$ D) $\pi(r_1 - r_2)h$
- 3) A cylindrical Pencil, sharpened at one end is a combination of
A) Sphere and Cylinder B) Cylinder and Cone
C) Cylinder and Hemi sphere D) Cone and sphere
- 4) The perimeter of the base of a right circular cylinder is 44 cm. And the height of the cylinder is 10 cm. then it's curved surface area is
A) 440 cm^2 B) 44 cm^2 C) 880 cm^2 D) 88 cm^2
- 5) A cylinder of height 10cm and the area of it's base is 154 cm^2 then the volume of the cylinder is
A) 1450 cm^3 B) 1540 cm^3 C) 4510 cm^3 D) 154 cm^3
- 6) A cone of slant height 10cm and the perimeter of it's base is 44cm. then the curved surface area of the cone is
A) 440 cm^2 B) 220 cm^2 C) 44.0 cm^2 D) 4400 cm^2
- 7) A cone of height 15cm and the area of it's base is 154 cm^2 then the volume of the cone is
A) 770 cm^3 B) 2013 cm^3 C) 2310 cm^3 D) 77 cm^3
- 8) A cone and a cylinder have equal base and equal heights. If the volume of the cylinder is 300 cm^3 then the volume of the cone is
A) 300 cm^3 B) 900 cm^3 C) 600 cm^3 D) 100 cm^3
- 9) A cone and a cylinder have equal base and equal heights. The volume of cone and cylinder are in the ratio,
A) 2 : 1 B) 3 : 1 C) 1 : 4 D) $\sqrt{2} : 3$
- 10) Formula used to find the total surface area of a solid hemi sphere is
A) $2\pi r^2$ B) $3\pi r^2$ C) $2\pi r^2$ D) $3\pi r^2 h$
- 11) The surface area of a sphere of radius 7cm is,
A) 616 cm^2 B) 61.6 cm^2 C) 313 cm^2 D) 31.3 cm^2
- 12) Formula used to find the total surface area of a cylinder is
A) $2\pi rh$ B) $2\pi r(h + r)$ C) $2\pi r^2 h$ D) $2\pi r(l + r)$
- 13) Formula used to find the volume of a cone is
A) $\frac{1}{3} \pi r^2 h$ B) $\frac{3}{2} \pi r^2 h$ C) $\pi r^2 h$ D) $\frac{4}{3} \pi r^2 h$

1 Mark Questions (VSA)

- 14) Write the formula to find the volume of a hemi sphere.
 15) Find the slant height of a cone of height 3 cm and the diameter of it's base is 8cm.
 16) Find the slant height of the frustum of a cone of height 5 cm and the difference between the radii of its two circular ends is 12cm.
 17) Name the solids in a petrol tanker.
 18) Write the formula to find the curved surface area of a cylinder.
 19) Find the volume of a cube whose side is 5 cm.
 20) Find the curved surface area of a hemi sphere whose radius is 7cm.

Ans.	1) D	2) A	3) B	4) A	5) B	6) B	7) A	8) D	9) B
10)B	11)A	12)B	13)A	14) $\frac{2}{3}\pi r^3$ cubic units			15) 5cm		16) 13cm
17) 1 Cylinder and 2 hemi sphere				18) $2\pi rh$ Sq. units			19) 125cm^3		20) 308cm^2

2 Marks Questions (SA)

- 21) **The slant height of a frustum of a cone is 4 cm. And the perimeters of its circular bases are 18cm and 6cm. Find it's curved surface area.**

Solution :- $l = 4$ cm, $2\pi r = 6$ cm, $2\pi R = 18$ cm.

$$2\pi r = 6, \quad \therefore \pi r = \frac{6}{2} = 3$$

$$2\pi R = 18, \quad \therefore \pi R = \frac{18}{2} = 9$$

$$\therefore \pi r + \pi R = 3 + 9$$

$$\therefore \pi(r + R) = 12 \text{-----} > (1)$$

$$\text{Curved surface area} = \pi(r + R)l$$

$$= 12 \times 4 = 48 \text{ cm}^2 \text{ (from eqn.(1) and } l = 4 \text{)}$$

- 22) The slant height of a frustum of a cone is 10.5 cm. And the radii of its circular bases are 33cm and 27cm. Find the curved surface area.

- 23) **A vessel is in the shape of a frustum of a cone. The radii of its circular bases are 28cm and 7cm and the height of the vessel is 45 cm. Find the volume of the vessel.**

Solution :- $h = 45$ cm, $r = 7$ cm, $R = 28$ cm

$$\text{Volume (V)} = \frac{1}{3}\pi h(r^2 + R^2 + R.r)$$

$$= \frac{1}{3} \times \frac{22}{7} \times 45 (7^2 + 28^2 + 28 \times 7)$$



$$= \frac{1}{3} \times \frac{22}{7} \times 45 (49 + 784 + 196)$$

$$= \frac{22}{7} \times 15 \times 1029$$

$$= 48510\text{cm}^3$$

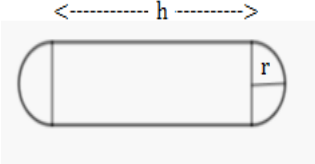
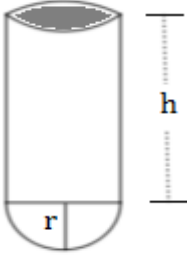
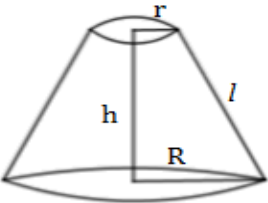
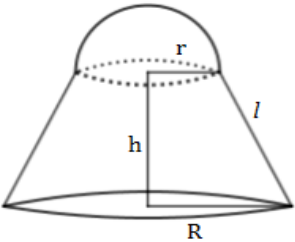
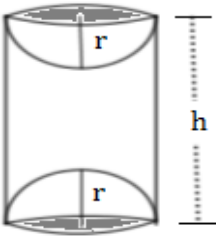
- 24) A drinking glass is in the shape of a frustum of a cone of height 14 cm. The diameters of its two circular ends are 4 cm and 2 cm. Find the capacity of the glass.
- 25) Combination of solids is given in the following table. Construct the formulae to find surface area and volume as shown in the table.

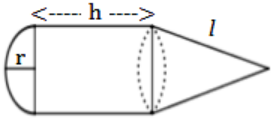
Combination of solids	Surface area	Volume
	$= (2 \times \text{surface area of a hemisphere}) + (\text{surface area of a cylinder})$ $= 2(2\pi r^2) + 2\pi rh$	$= (2 \times \text{volume of a hemisphere}) + (\text{volume of a cylinder})$ $= 2\left(\frac{2}{3}\pi r^3\right) + \pi r^2 h$
		
		
		
		

Combination of solids	Surface area	Volume
		
		

3/4 Marks Questions (LA-1/ LA-2)

- 26) A cone of height 24 cm and radius of base 6 cm is made up of modelling clay.

A student reshapes it in the form of a sphere. Find the radius of the sphere.

Solution :- height of a cone $h = 24$ cm, radius of base $r = 6$ cm,

Let R be the radius of a sphere.

Given, Volume of a cone = Volume of a sphere

$$\frac{1}{3} \pi r^2 h = \frac{4}{3} \pi R^3$$

$$\frac{1}{3} \pi (r^2 h) = \frac{1}{3} \pi (4R^3) \quad [\because \text{cancelling } \frac{1}{3} \pi \text{ on both sides}]$$

$$r^2 h = 4R^3$$

$$6^2 \times 24 = 4R^3$$

$$6^2 \times 6 \times 4 = 4R^3 \quad [\because \text{cancelling } 4 \text{ on both sides}]$$

$$6^3 = R^3$$

$$R = 6 \text{ cm}$$

\therefore Radius of a sphere $R = 6$ cm

- 27) The length and breadth of the roof of an auditorium are 22 m and 20 m respectively. The rain water from this roof is drains into a cylindrical vessel having diameter of base 2 m and height 3.5m. If the vessel is just full, find the rain fall in cm.

Solution: Let the rainfall be x cm $= \frac{x}{100}$ m

Length of roof $l = 22$ m and breadth of roof $b = 20$ m and $V = lbh$

$$\therefore \text{Volume of water on the roof} = 22 \times 20 \times \frac{x}{100} = \frac{22x}{5} \text{ m}^3 \text{ ---> (1)}$$

Radius of the base of cylindrical vessel = 1m. ($\because d = 2m$)

Height of the cylindrical vessel = 3.5m.

Volume of water in cylindrical vessel when just full = $\pi r^2 h$

$$= \frac{22}{7} \times 1^2 \times 3.5 = 11 \text{ m}^3 \text{ -----} (2)$$

\therefore Volume of water on the roof = Volume of water in cylindrical vessel

$$\Rightarrow \frac{22x}{5} = 11 \quad [\because \text{from (1) and (2)}]$$

$$x = \frac{11 \times 5}{22}$$

$$x = \frac{5}{2}$$

$$x = 2.5$$

Hence, the rainfall is = 2.5 cm

28) 2 cubes each of volume 64 cm^3 are joined end to end. Find the surface area of the resulting cuboid.

29) Combination of some solids are given below. Find the surface area and the volume of each solid.

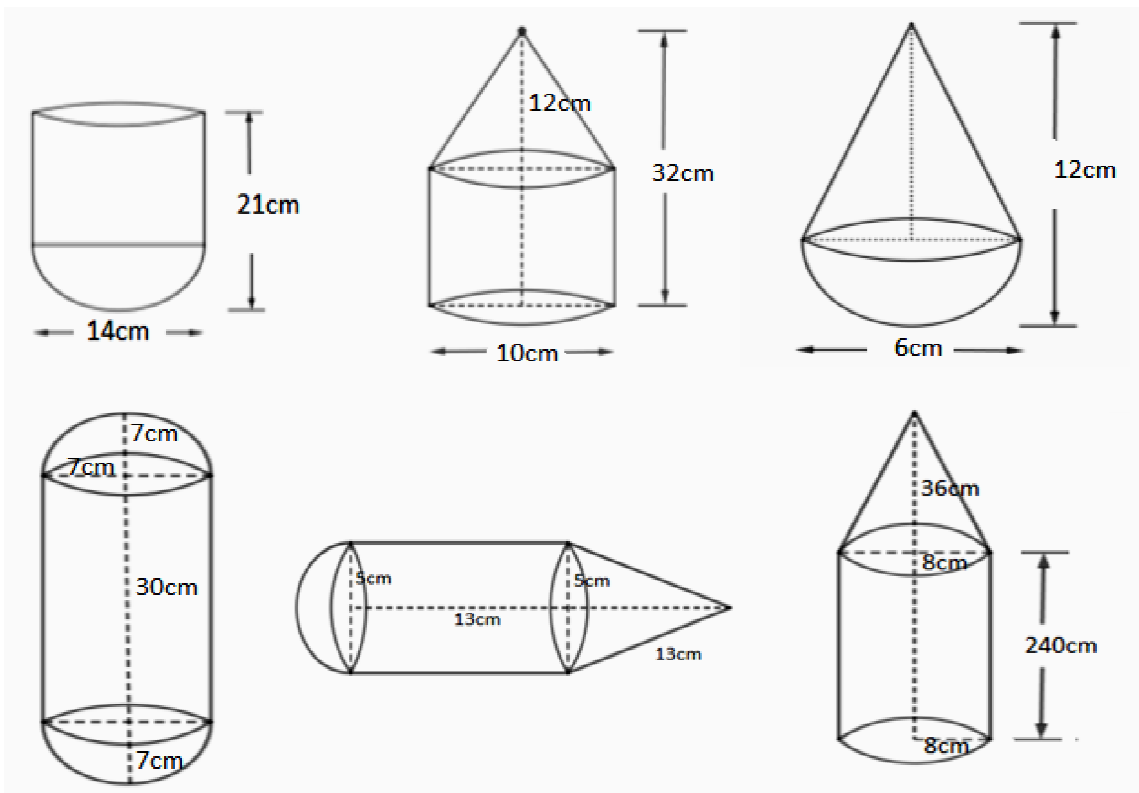

30) Combination of some solids are given below. Find the volume of each solid.

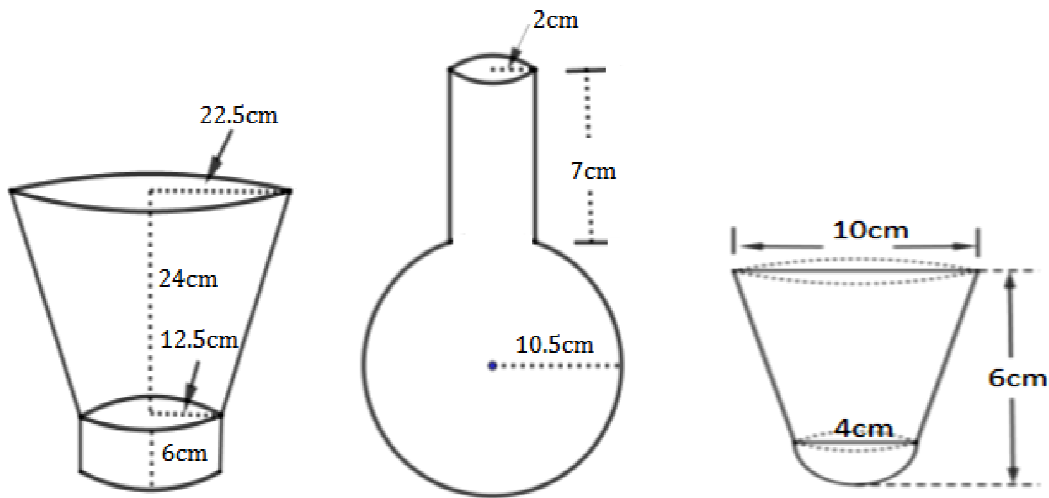

5 Marks Questions (LA-3)

31) A metallic right circular cone 20cm high and whose vertical angle is 60° is cut into two parts at the middle of its height by a plane parallel to its base. If the frustum so obtained be drawn into a wire of diameter $\frac{1}{15}$ cm, find the length of the wire.

Solution: as shown in the figure
vertical angle $\angle BAC = 60^\circ$

$$\therefore \angle OAB = 30^\circ$$

Height of cone $OA = 20\text{cm}$

DE intersects Cone such that

$$AP = OP = 10\text{ cm}$$

$$\therefore OP = h_1 = 10\text{cm}$$

Radii of frustum of cone

$$DP = r_1 = ?, \quad OB = r_2 = ?$$

From the right triangle APD,

$$\tan 30^\circ = \frac{\text{opp}}{\text{adj}} = \frac{DP}{AP}$$

$$\frac{1}{\sqrt{3}} = \frac{r_2}{10}$$

$$r_2 = \frac{10}{\sqrt{3}} \text{ ---->(1)}$$

From the right triangle AOB,

$$\tan 30^\circ = \frac{\text{opp}}{\text{adj}} = \frac{OB}{OA}$$

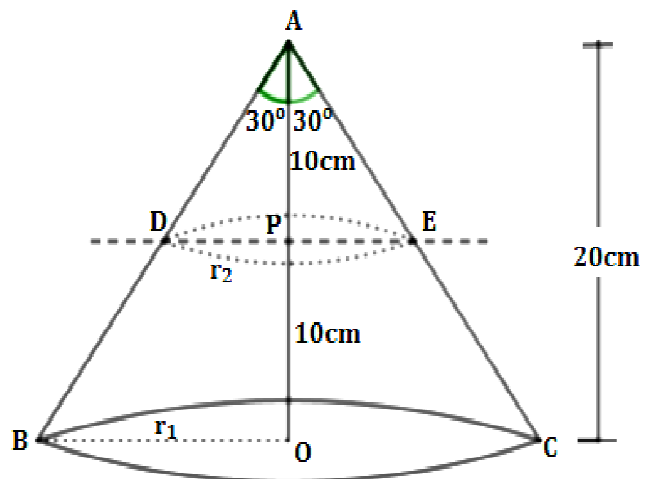

$$\frac{1}{\sqrt{3}} = \frac{r_1}{20}$$

$$r_1 = \frac{20}{\sqrt{3}} \text{ ---->(2)}$$

The wire is in the form of a cylinder.

Length of the wire l = height of the cylinder h = ?

Radius of the wire $r = \frac{1}{2} \times \frac{1}{15} \text{ cm} = \frac{1}{30} \text{ cm}$ ($\because r = \frac{1}{2} \times d$)

Volume of the wire = Volume of the frustum of the cone

$$\pi \times r^2 \times h = \frac{1}{3} \pi h_1 (r_1^2 + r_2^2 + r_1 \cdot r_2)$$

$$\pi \times \left(\frac{1}{30}\right)^2 \times l = \frac{1}{3} \pi \times 10 \left[\left(\frac{20}{\sqrt{3}}\right)^2 + \left(\frac{10}{\sqrt{3}}\right)^2 + \frac{20}{\sqrt{3}} \times \frac{10}{\sqrt{3}} \right]$$

$$\frac{1}{900} \times l = \frac{1}{3} \times 10 \left(\frac{400}{3} + \frac{100}{3} + \frac{200}{3} \right)$$

$$\frac{1}{900} \times l = \frac{1}{3} \times 10 \left(\frac{700}{3} \right)$$

$$l = \frac{7000}{9} \times 900 \text{ cm}$$

$$l = 7000 \times 100 \text{ cm}$$

$$l = 7000 \text{ m}$$

\therefore Length of the wire = 7000 m

For more drill work

- 1) If the p^{th} term of an AP be $\frac{1}{q}$ and its q^{th} term be $\frac{1}{p}$, then show that the sum of its $(pq)^{\text{th}}$ terms is $\frac{1}{2}(pq + 1)$.

Solution: In an AP, p^{th} term $a_p = \frac{1}{q}$, q^{th} term $a_q = \frac{1}{p}$

$$d = \frac{a_p - a_q}{p - q}$$

$$d = \frac{\frac{1}{q} - \frac{1}{p}}{p - q}$$

$$d = \frac{\frac{p - q}{pq}}{p - q}$$

$$d = \frac{(p - q)}{pq(p - q)}$$

$$d = \frac{1}{pq} \quad \text{-----}>(1)$$

$$a_p = \frac{1}{q}$$

$$a + (p - 1)d = \frac{1}{q} \quad [\because a_n = a + (n - 1)d]$$

$$a + (p - 1)\frac{1}{pq} = \frac{1}{q} \quad [\because \text{From (1)}]$$

$$a + \frac{p}{pq} - \frac{1}{pq} = \frac{1}{q}$$

$$a + \frac{1}{q} - \frac{1}{pq} = \frac{1}{q}$$

$$a = \frac{1}{pq} \quad \text{-----}>(2) \quad (\because \text{cancelling } \frac{1}{q} \text{ on both sides})$$

$$S_n = \frac{n}{2}[2a + (n - 1)d]$$

Put $n = pq$,

$$S_{pq} = \frac{pq}{2} \left[2 \times \frac{1}{pq} + (pq - 1) \frac{1}{pq} \right] \quad [\because \text{From (1) and (2)}]$$

$$S_{pq} = \frac{pq}{2} \times \frac{1}{pq} (2 + pq - 1)$$

$$\text{Hence, } S_{pq} = \frac{1}{2}(pq + 1)$$

- 2) If the p^{th} term of an AP be q and its q^{th} term be p , then show that the sum of its $(p+q)^{\text{th}}$ terms is $\frac{1}{2}(p+q)(p+q-1)$.
- 3) **The first, second and the last terms of an AP are a, b and $2a$ respectively. Show that the sum of the terms is $\frac{3ab}{2(b-a)}$.**

Solution: $a_1 = a, a_2 = b$ and $a_n = 2a$

$$d = a_2 - a_1$$

$$d = b - a \text{ ---->(1)}$$

$$a + (n - 1)d = a_n$$

$$(n - 1)d = a_n - a$$

$$(n - 1) = \frac{2a - a}{d} \quad (\because a_n = 2a)$$

$$n - 1 = \frac{a}{d}$$

$$n - 1 = \frac{a}{b - a} \text{ ---->(2)} \quad [\because \text{From (1)}]$$

$$n = \frac{a}{b - a} + 1$$

$$n = \frac{a + b - a}{b - a}$$

$$n = \frac{b}{b - a} \text{ ---->(3)}$$

$$S_n = \frac{n}{2}[2a + (n - 1)d]$$

$$S_n = \frac{1}{2} \times \frac{b}{b - a} \left[2a + \left(\frac{a}{b - a} \right) (b - a) \right] \quad [\because \text{From (1), (2) and (3)}]$$

$$S_n = \frac{b}{2(b - a)} (2a + a)$$

$$S_n = \frac{b}{2(b - a)} (3a)$$

$$\text{Hence, } S_n = \frac{3ab}{2(b - a)}$$

- 4) The sum of first 20 terms of an AP is 400 and that of the first 40 terms is 1600. Find the sum of its first 10 terms.
- 5) The sum of first three terms of an AP is 21 and that of the last three terms is 276. Find the sum of its first 20 terms.

- 6) If the middle term of an AP is 49, find the sum of its first 25 terms.
- 7) The sum of middle three terms of an AP is 225 and that of the last three terms is 429. If there are 37 terms, find AP.
- 8) The interior angles of a quadrilateral are in AP. If the smallest angle of the quadrilateral is 27° , find the remaining angles.
- 9) The sum of all four numbers of an AP is 58. If the difference between the extremes is 9, find the numbers.
- 10) The sum of first six terms of an AP is 42. If the ratio to the 10th and 30th terms is 1:3, find its 1st and 13th term.
- 11) Prove that $\sqrt{\frac{1+\sin \theta}{1-\sin \theta}} + \sqrt{\frac{1-\sin \theta}{1+\sin \theta}} = 2 \sec \theta$.
- 12) An aeroplane when flying at a height of 4000 m from the ground passes vertically above another aeroplane, at an instant when the angles of the elevation of the two planes from the same point on the ground are 60° and 45° respectively. Find the vertical distance between the aeroplanes at that instant.
- 13) A man on a cliff observes a boat at an angle of depression of 30° which is approaching the shore to the point immediately beneath the observer with a uniform speed. Six minutes later, the angle of depression of the boat is found to be 60° . Find the time taken by the boat to reach the shore.
- 14) If the angle of elevation of the stationary cloud from a point h metres above a lake is α and angle of depression of its reflection in the lake is β , prove that the height of the cloud is $\frac{h(\tan \beta + \tan \alpha)}{\tan \beta - \tan \alpha}$.
- 15) If the angle of elevation of the stationary cloud from point 60 metres above a lake is 30° and angle of depression of its reflection in the lake is 60° , find the height of the cloud.
- 16) A tent is made in the form of a conic frustum surmounted by a cone. The diameters of the base and the top of the frustum are 20m and 6m respectively and the height is 24m. If the height of the tent is 28 m, find the quantity of canvas required.
- 17) **Due to sudden floods, some welfare associations jointly requested the government to get 100 tents fixed immediately and offered to contribute 50% of the cost. If the lower part of each tent is of the form of a cylinder of diameter 4.2 m and height 4m with the conical upper part of same diameter but height 2.8m, and the canvas to be used cost Rs.100 per sq.m, find the amount the associations will have to pay. What values are shown by these associations. (take $\pi = \frac{22}{7}$)**

Solution : Tents are made in the form of a cylinder surmounted by a cone.

For cylinder and cone diameter $d = 4.2$ m

$$\therefore r = \frac{4.2}{2} = 2.1\text{m}$$

Height of the cylinder $H = 4\text{m}$

Height of the cone $h = 2.8\text{m}$

Slant height of the cone $l = ?$

$$l^2 = r^2 + h^2$$

$$l^2 = (2.1)^2 + (2.8)^2$$

$$l^2 = 4.41 + 7.84$$

$$l = \sqrt{12.25}$$

$$l = 3.5\text{m}$$

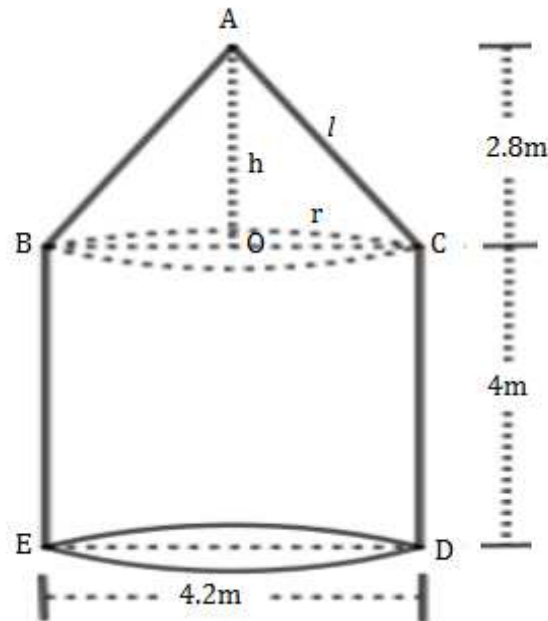

Curved surface area of the tent = (C.S.A. of the cylinder + C.S.A. of the cone)

$$\text{Curved surface area of the tent} = 2\pi rH + \pi rl$$

$$= \pi r(2H + l)$$

$$= \frac{22}{7} \times 2.1(2 \times 4 + 3.5)$$

$$= 22 \times 0.3 \times 11.5$$

$$\text{Curved surface area of the tent} = 75.90\text{m}^2$$

$$\therefore \text{Curved surface area of 100 such tents} = 75.90 \times 100 = 7590\text{m}^2$$

If the cost of 1m^2 canvas is Rs 100,

$$\text{cost of } 7590\text{m}^2 \text{ canvas} = 7590 \times 100 = \text{Rs } 7,59,000$$

$$50\% \text{ of the cost} = \text{Rs } 7,59,000 \times \frac{50}{100} = \text{Rs } 3,79,500$$

\therefore Amount contributed by some welfare associations is Rs 3,79,500

Values: * It is a symbol of humanity.

* It is a characteristic of good civilization.

- 18) Due to heavy floods in a state, thousands were rendered homeless. 50 schools collectively offered to the state government to provide place and the canvas for 1500 tents to be fixed by the government and decided to share the whole expenditure equally. The lower part of each tent is cylindrical of base radius 2.8m and height 3.5m with conical upper part of same base radius but of height 2.1m. If the canvas used to make the tents cost Rs 120 per square metre find the amount shared by each school to setup the tents. What value is generated by the above problem. (Take $\pi = \frac{22}{7}$)

- 19) A right circular cone is divided by a plane parallel to its base in two equal volumes. In what ratio will the plane divide the axis of the cone?

- 20) The height of a right circular cone is trisected by two planes drawn parallel to the base. Show that the volumes of the three portions starting from the top are in the ratio 1:7:19
- 21) A right triangle, whose sides are 15cm and 20cm, is made to revolve about its hypotenuse. Find the volume and surface area of the double cone so formed.
(Take $\pi = 3.14$)
- 22) A vessel is in the form of an inverted cone. Its height is 11 cm and the diameter of its top, which is open, is 5 cm. It is filled with water up to the rim. When lead shots, each of which is a sphere of radius $\frac{1}{4}$ cm, are dropped into the vessel, $\frac{2}{5}$ of the water flows out. Find the number of lead shots dropped into the vessel.

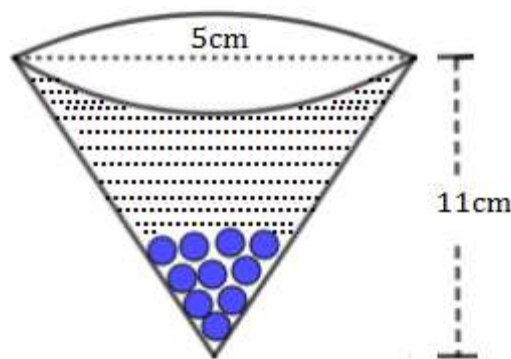

- 23) In the adjoining figure, the slant height of a right circular conical vessel is 10 cm. And its height is 8 cm. It is filled with water up to the rim. A Iron sphere of radius equal to half of the radius of conical vessel, is then immersed in the water such that the sphere touches the water level as shown in the figure. Show that the volume of water displaced from the vessel and the volume of water remaining in the vessel are in the ratio 3:5.

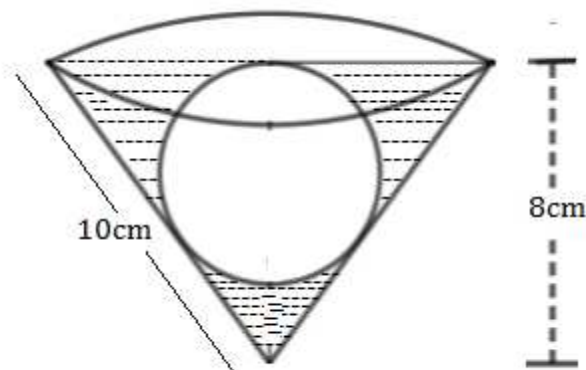

- 24) Two solid cones are placed in a cylindrical tube as shown in the figure. If the capacities of the cones are in the ratio 2:3, find the volume of the remaining portion of the cylinder.

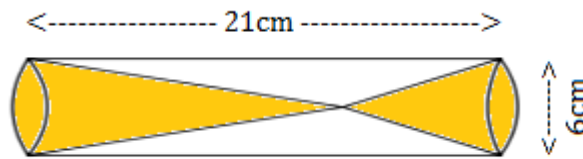

- 25) A ladder 6.5 m long, placed against a wall reaches a window 6 m above the ground. If the foot of the ladder slips 3.5 m, how high above the ground will be the other end of the ladder.
- 26) In the adjoining figure, BC is the diameter of the semi-circle with centre at point O. Centres of the three equal semi-circles lie on BC. ABC is an isosceles triangle with $AB=AC$. If $BC = 84$ cm, find the area of the shaded region. (Take $\pi = \frac{22}{7}$)

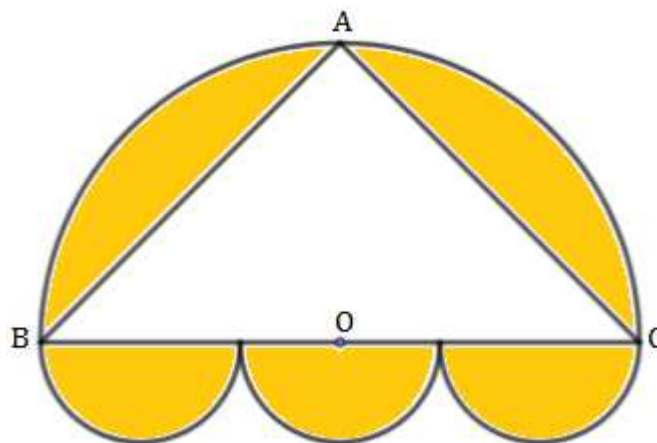

Note : Dear students, from page 116 to page 123 contains some model practice questions based on minimum learning outcomes. To ensure learning, you can confirm your minimal level of learning by solving these model practice questions.

Practice Questions : Set – 1

 $2 \times 8 = 16$

- 1) Find the sum of first 20 terms of the AP 2, 5, 8, 11,
- 2) Solve by elimination method
 $x + 2y = 8$
 $2x + y = 7$
- 3) Find the distance between the points $(-3, 4)$ and $(5, -2)$.
- 4) Prove that $2\sqrt{3} - 4$ is an irrational number.
- 5) Find the sum of zeroes and the product of zeroes of the polynomial $2x^2 - 5x + 3$.
- 6) Find the roots of the quadratic equation $x^2 = 8x + 1$ using quadratic formula.
- 7) Determine the nature of roots of the quadratic equation $x^2 + 3x - 1 = 0$.
- 8) If $15 \cot A = 8$ find the values of $\sin A$ and $\sec A$.
- 9) Calculate the Mode for the given data. $3 \times 5 = 15$

CI	10 - 20	20 - 30	30 - 40	40 - 50	50 - 60
f	7	4	8	2	4

- 10) Draw a circle of radius 4 cm and construct tangents to it from an external point 10 cm away from its centre. Measure and write the length of tangents.
- 11) Construct a ΔABC in which $AB = 5\text{cm}$, $BC = 6\text{cm}$ and $CA = 7\text{cm}$. Then construct another triangle whose corresponding sides are $\frac{5}{4}$ of the sides of the ΔABC .
- 12) Prove that “ the length of tangents drawn from an external point to a circle are equal ”.
- 13) Draw the ‘less than ogive’ for the given data.

Weight (in Kgs)	No. of Students
Less than 28	0
Less than 30	3
Less than 32	7
Less than 34	12
Less than 36	20
Less than 38	32
Less than 40	40

- 14) Solve graphically: $x + 2y = 11$ $4 \times 1 = 4$
 $x + y = 8$
- 15) State and prove Basic proportionality theorem. $5 \times 1 = 5$

Practice Questions : Set - 2

 $2 \times 8 = 16$

- 1) Find the sum of first 15 terms of the AP 3, 7, 11, 15,
- 2) Solve by elimination method
 $x + 2y = 8$
 $2x - 3y = 2$
- 3) Find the co ordinates of the mid point of the line segment joining the points (7, -5) and (-2, -3).
- 4) Prove that $2 + \sqrt{5}$ is an irrational number.
- 5) Find the sum of zeroes and the product of zeroes of the polynomial $3x^2 - 5x + 2$.
- 6) Find the roots of the quadratic equation $x^2 - 5x - 2 = 0$ using the formula.
- 7) Determine the nature of roots of the quadratic equation $3x^2 + 4x - 2 = 0$.
- 8) If $\sqrt{2} \sin \theta = 1$ find the values of $\cos \theta$ and $\cot \theta$.
- 9) Calculate the Median for the given data. $3 \times 5 = 15$

CI	30 - 35	35 - 40	40 - 45	45 - 50	50 - 55	55 - 60
f	4	7	5	5	10	9

- 10) Draw a circle of radius 4 cm. Construct two tangents to it such that the tangents are inclined at 70° . Measure and write the length of tangents.
- 11) Construct a ΔABC in which $AB = 7\text{cm}$, $\angle B = 60^\circ$ and $BC = 5\text{cm}$. Then construct another triangle whose corresponding sides are $\frac{5}{3}$ of the sides of the ΔABC .
- 12) Find the area of the triangle formed by joining the points (-3, 2), (2, -4) and (1, 3).
- 16) Draw the 'more than ogive' for the given data.

Policy Amount (in lakh rupees)	No. of policy holders
5 or more than 5	50
10 or more than 10	42
15 or more than 15	30
20 or more than 20	25
25 or more than 25	11
30 or more than 30	6

- 13) Solve graphically: $2x + y = 8$ $4 \times 1 = 4$
 $x - 1 = y$
- 14) State and prove 'Pythagoras theorem'. $5 \times 1 = 5$

Practice Questions : Set – 3

 $2 \times 8 = 16$

- 1) Find the 35th term of the AP 21, 18, 15, 12,
- 2) Solve by elimination method
 $3x + y = 10$
 $2x - y = 5$
- 3) Find the distance between the points (6, 4) and (3, 1).
- 4) Find the polynomial whose sum of zeroes is -3 and the product of the zeroes is 2.
- 5) Show that the quadratic equation $3x^2 - 4\sqrt{3}x + 4 = 0$ has two equal real roots.
- 6) Find the roots of the quadratic equation $x^2 - 4 = 3x$ using the formula.
- 7) If $2 \cos \theta = 1$ find the values of $\sin \theta$ and $\cot \theta$.
- 8) Prove that $2 - \sqrt{5}$ is an irrational number.
- 9) Calculate the Mean for the given data. $3 \times 5 = 15$

CI	15 - 25	25 - 35	35 - 45	45 - 55	55 - 65	65 - 75
f	5	10	7	4	3	1

- 10) Draw a circle of radius 3.5 cm. Construct two tangents to it such that the tangents are inclined at 50° . Measure and write the length of tangents.
- 11) Construct an isosceles triangle whose base is 8cm and altitude 4 cm and then another triangle whose sides are $1\frac{1}{2}$ times the corresponding sides of the isosceles triangle.
- 12) Prove that "The tangent at any point of a circle is perpendicular to the radius through the point of contact".
- 13) Change the following distribution to a 'less than type distribution', and draw its ogive.

CI	0 - 3	3 - 6	6 - 9	9 - 12	12 - 15
f	9	3	5	3	1

- 14) Solve graphically: $2x + y = 9$ $4 \times 1 = 4$
 $x + y = 6$
- 15) State and prove A.A.A. similarity criterion. $5 \times 1 = 5$

Practice Questions : Set - 4

 $2 \times 8 = 16$

- 1) Find the sum of first 20 terms of the AP 3, 10, 17, 24,
- 2) Solve by elimination method
 $3x + 2y = 19$
 $5x - 2y = 21$
- 3) Find the distance between the points (2, 3) and (-2, -3).
- 4) Find the quadratic polynomial whose zeroes are 2 and -5.
- 5) Find the roots of the quadratic equation $5x + 1 = x^2$ using suitable formula.
- 6) Show that the quadratic equation $2x^2 - 4x + 3 = 0$ has no real roots.
- 7) Find the value of $12 \sin^2 30^\circ + 7 \tan^2 45^\circ - 8 \cos^2 60^\circ$.
- 8) Prove that $5 - \sqrt{3}$ is an irrational number.
- 9) Calculate the Median for the given data. $3 \times 5 = 15$

CI	0 - 10	10 - 20	20 - 30	30 - 40	40 - 50	50 - 60
f	5	4	11	10	7	3

- 10) Draw a circle of radius 4 cm. Construct two tangents to it such that the tangents are inclined at 80° . Measure and write the length of tangents.
- 11) Construct a ΔABC in which $AB = 6\text{cm}$, $BC = 8\text{cm}$ and $CA = 10\text{cm}$. Then construct another triangle whose corresponding sides are $\frac{3}{4}$ of the sides of the ΔABC .
- 12) If the points (2, 3), (4, k) and (6, -3) are collinear, find the value of k.
- 13) Draw the 'less than ogive' for the given data.

Daily wages (in ₹.)	No. of workers
Less than 450	2
Less than 500	8
Less than 550	20
Less than 600	38
Less than 650	62
Less than 700	75
Less than 750	80

- 14) Solve graphically: $x + y = 8$ $4 \times 1 = 4$
 $2x - y = 7$
- 15) State and prove the converse of Pythagoras theorem. $5 \times 1 = 5$

Practice Questions : Set – 5

 $2 \times 8 = 16$

- 1) Find the 15th term of the AP 2, 11, 20, 29, ... using suitable formula.
- 2) Solve the given equations by elimination method :

$$5x + y = 26$$

$$5x - 8y = 17$$
- 3) Find the distance between the points $(-2, -4)$ and $(2, 4)$.
- 4) Find the quadratic polynomial whose zeroes are -2 and 3 .
- 16) Find the roots of the quadratic equation $x^2 + x = 6$ using formula.
- 5) A lot of 100 bulbs contain 7 defective bulbs. One bulb is drawn at random from the lot. What is the probability that this bulb is not defective.
- 6) In ΔABC $\angle B = 90^\circ$, $AB = 8\text{cm}$ and $BC = 6\text{cm}$. Find the values of $\sin A$ and $\cos A$.
- 7) Prove that $3 + \sqrt{5}$ is an irrational number.
- 8) Calculate the Mode for the given data. $3 \times 5 = 15$

CI	0 - 10	10 - 20	20 - 30	30 - 40	40 - 50	50 - 60
f	8	9	10	16	12	6

- 9) Draw a circle of radius 3.5 cm and construct tangents to it from an external point 7 cm away from its centre. Measure and write the length of tangents.
- 10) Construct a ΔABC in which $AB = 7\text{cm}$, $BC = 5\text{cm}$ and $CA = 6\text{cm}$. Then construct another triangle whose corresponding sides are $\frac{7}{5}$ of the sides of the ΔABC .
- 11) Prove that “ the length of tangents drawn from an external point to a circle are equal ”.
- 12) Draw the ‘more than ogive’ for the given data.

Production yield of wheat (in Kg/ha)	No. of farms
40 or more than 40	100
45 or more than 45	96
50 or more than 50	90
55 or more than 55	74
60 or more than 60	54
65 or more than 65	24

- 13) Find the solution of the pair of linear equations by graphical method :

$$2x + y = 6$$

$$x + 2y = 9$$
 $4 \times 1 = 4$
- 14) Prove that “the ratio of the areas of two similar triangles is equal to the square of the ratio of their corresponding sides”. $5 \times 1 = 5$

Practice Questions : Set – 6

$2 \times 8 = 16$

- 1) Find the sum of first 20 terms of an Arithmetic series $5 + 10 + 15 + \dots$ using suitable formula.
- 2) Solve using elimination method :

$$2x + 3y = 11$$

$$2x - 4y = -24$$
- 3) Find the distance between the points (2, 3) and (4, 7) using distance formula.
- 4) Prove that $5 - 2\sqrt{3}$ is an irrational number.
- 5) If the sum of zeroes of the polynomial $p(x) = 2x^2 - 6x + k$ is equal to half of the product of zeros, then find the value of k .
- 6) Find the discriminant of the quadratic equation $2x^2 - 5x - 1 = 0$ and hence determine the nature of roots.
- 7) Solve using quadratic formula : $x^2 - 3x + 1 = 0$
- 8) In the adjoining figure find the values of $\sin\theta$ and $\cos\alpha$.
- 9) Calculate the Mode for the following data. $3 \times 5 = 15$

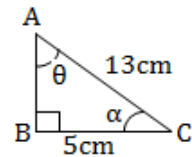

CI	0 - 5	5 - 10	10 - 15	15 - 20	20 - 25
f	8	9	5	3	1

- 10) Draw a circle of radius 3.5 cm. Construct two tangents to it such that the tangents are inclined at 60° . Measure and write the length of tangents.
- 11) Construct a triangle with sides 6 cm, 7 cm and 8 cm and then another triangle whose sides are $\frac{3}{4}$ of the corresponding sides of the first triangle.
- 12) Find the area of the triangle whose vertices are A(0, 6) B(8, 0) and C(5, 8).
- 13) Draw the 'more than ogive' for the given data.

Age (in years)	No. of policy holders
Less than 20	2
Less than 25	6
Less than 30	12
Less than 35	16
Less than 40	20
Less than 45	25
Less than 50	35

- 14) Solve graphically : $2x + y = 10$ $4 \times 1 = 4$
 $x + y = 6$
- 15) Prove that "if in two triangles, corresponding angles are equal, then their corresponding sides are in the same ratio and hence the two triangles are similar".

Practice Questions : Set – 7

$2 \times 7 = 14$

- 1) Find the 11th term of the AP $-3, -1, 1, 3, \dots$
- 2) If the n th term of an arithmetic progression is $a_n = 3n - 2$, then find sum of first 9 terms.
- 3) Solve the following pair of linear equations by any suitable method:
 $x + y = 5$
 $2x - 3y = 5$

ORFind the value of k for which the given pair of linear equations is inconsistent.

$2x - 3y = 8$

$2(k - 4)x - ky = k + 3$

- 4) 'O' is the centre of the two concentric circles of radii 5 cm and 3 cm. Find the length of the chord of the larger circle which touches the smaller circle.
- 5) Find the value of the Discriminant of the quadratic equation $2x^2 - 4x + 3 = 0$
- 6) Find the value of $(\sin 30^\circ + \cos 60^\circ - \tan 45^\circ)$.
- 7) Prove that the points A (8, -4), B (9, 5) and C (0, 4) are the vertices of an isosceles triangle.
- 8) Calculate the Median for the following data. $3 \times 6 = 18$

Weight (in Kg)	15-20	20-25	25-30	30-35	35-40
No. of students	2	3	6	4	5

- 9) The following table gives production yield per hectare of wheat of 100 farms of a village. Change the distribution to a 'more than type' distribution, and draw its ogive.

Production yield (in Kg/ha)	50-55	55-60	60-65	65-70	70-75	75-80
No. of farms	2	8	12	24	38	16

- 10) Draw a circle of radius 3.5 cm. Construct two tangents to it such that the tangents are inclined at 80° . Measure and write the length of tangents.
- 15) Construct a ΔABC in which $BC = 3\text{cm}$, $AB = 6\text{cm}$ and $AC = 4.5\text{cm}$. Then construct another triangle whose corresponding sides are $\frac{4}{3}$ of the sides of the first triangle.
- 11) Find the coordinates of the point which divides the line joining the points (1, 6) and (4, 3) in the ratio 1 : 2.
- 12) Prove that $\sqrt{5}$ is an irrational number.
- 13) Find the solution of the pair of linear equations by graphical method :
 $2x + y = 6$ $4 \times 2 = 8$
 $2x - y = 2$
- 14) State and prove 'Pythagoras theorem'.

Practice Questions : Set – 8

 $2 \times 8 = 16$

- 1) Find the 15th term of the AP 3, 8, 13, 18,
- 2) Solve using elimination method :
 $3x + 2y = 11$
 $5x - 2y = 13$
- 3) Find the distance between the points (8, 3) and (2, 11) using formula.
- 4) Find the roots of the quadratic equation $2x^2 + x - 4 = 0$ using formula.
- 5) Find the value of k for which the quadratic equation $kx^2 + 6x + 1 = 0$ has two real equal roots.
- 6) If $\tan A = \frac{4}{3}$ find the values of $\cos A$ and $\operatorname{cosec} A$.
- 7) Draw a line segment of length 8cm and divide it in the ratio 2 : 3 by geometric construction.
- 8) Draw a circle of radius 3 cm. Construct a pair of tangents to it such that the tangents are inclined at 70° .
- 9) Find the Mean for the following data. $3 \times 5 = 15$

CI	0 - 10	10 - 20	20 - 30	30 - 40	40 - 50
f	12	16	6	7	9

- 10) Construct a triangle with sides 4 cm, 6 cm and 8 cm and then another triangle whose sides are $\frac{3}{4}$ of the corresponding sides of the first triangle.
- 15) Find the coordinates of the point which divides the line joining the points (4, -3) and (8, 5) in the ratio 3 : 1.
- 11) On dividing $p(x) = 3x^3 + x^2 + 2x + 5$ by a polynomial $g(x)$, the quotient and remainder are $(3x - 5)$ and $(9x + 10)$ respectively. Find $g(x)$.
- 11) The following table gives production yield per hectare of wheat of 100 farms of a village. Change the distribution to a 'less than type' distribution, and draw its ogive.

Production yield (in Kg/ha)	40-45	45-50	50-55	55-60	60-65	65-70
No. of farms	4	6	16	20	30	24

- 16) Find the solution of the pair of linear equations by graphical method :
 $x - 2y = 0$ $4 \times 1 = 4$
 $3x + 4y = 20$
- 17) Prove that "the ratio of the areas of two similar triangles is equal to the square of the ratio of their corresponding sides". $5 \times 1 = 5$