

PHYSICS (Theory)

Time allowed : 3 hours

Maximum Marks : 70

General Instructions:

- (i) All questions are compulsory.
- (ii) There are 30 questions in total. Questions 1 to 8 are very short answer type questions and carry one marks each.
- (iii) Questions 9 to 18 carry two marks each, questions 19 to 27 carry three marks each and questions 28 to 30 carry five marks each.
- (iv) There is no overall choice. However, an internal choice has been provided in one question of two marks, one question of three marks and all three questions of five marks each. You have to attempt only one of the given choices in such questions.
- (v) Use of calculators is **not** permitted. However, you may use log tables if necessary.
- (vi) You may use the following physical constants wherever necessary:

$$c = 3 \times 10^8 \text{ m/s}$$

$$h = 6.63 \times 10^{-34} \text{ Js}$$

$$e = 1.6 \times 10^{-19} \text{ C}$$

$$\mu_0 = 4\pi \times 10^{-7} \text{ T mA}^{-1}$$

$$\frac{1}{4\pi\epsilon_0} = 9 \times 10^9 \frac{\text{Nm}^2}{\text{C}^2}$$

$$m_e = 9.1 \times 10^{-31} \text{ kg}$$

QUESTION PAPER CODE 51/1/1

1. A point charge Q is placed at point O as shown in the figure. Is the potential difference $V_A - V_B$ positive, negative or zero, if Q is (i) positive (ii) negative? 1



2. A plane electromagnetic wave travels in vacuum along z -direction. What can you say about the direction of electric and magnetic field vectors? 1
3. A resistance R is connected across a cell of emf ϵ and internal resistance r . A potentiometer now measures the potential difference between the terminals of the cell as V . Write the expression for ' r ' in terms of ϵ , V and R . 1
4. The permeability of a magnetic material is 0.9983. Name the type of magnetic materials it represents. 1
5. Show graphically, the variation of the de-Broglie wavelength (λ) with the potential (V) through which an electron is accelerated from rest. 1
6. In a transistor, doping level in base is increased slightly. How will it affect (i) collector current and (ii) base current? 1
7. Define the term 'wattless current'. 1
8. When monochromatic light travels from one medium to another its wavelength changes but frequency remains the same, Explain. 1
9. Two uniformly large parallel thin plates having charge densities $+\sigma$ and $-\sigma$ are kept in the X - Z plane at a distance ' d ' apart. Sketch an equipotential surface due to electric field between the plates. If a particle of mass m and charge ' $-q$ ' remains stationary between the plates, what is the magnitude and direction of this field? 2

OR

Two small identical electrical dipoles AB and CD , each of dipole moment ' p ' are kept at an angle of 120° as shown in the figure. What is the resultant dipole moment

of this combination ? If this system is subjected to electric field (\vec{E}) directed along + X direction, what will be the magnitude and direction of the torque acting on this ?

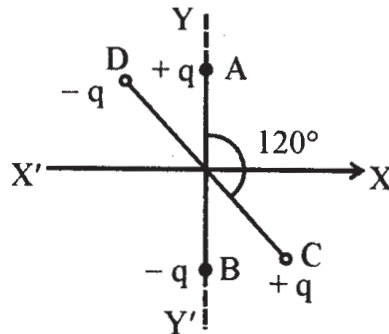

10. A magnetic needle free to rotate in a vertical plane parallel to the magnetic meridian has its north tip down at 60° with the horizontal. The horizontal component of the earth's magnetic field at the place is known to be 0.4 G. Determine the magnitude of the earth's magnetic field at the place.

2

11. Figure shows two identical capacitors, C_1 and C_2 , each of $1 \mu\text{F}$ capacitance connected to a battery of 6 V. Initially switch 'S' is closed. After sometime 'S' is left open and dielectric slabs of dielectric constant $K = 3$ are inserted to fill completely the space between the plates of the two capacitors. How will the (i) charge and (ii) potential difference between the plates of the capacitors be affected after the slabs are inserted ?

2

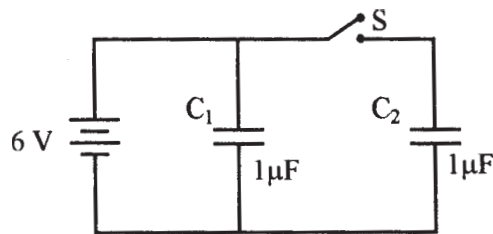

12. Two convex lenses of same focal length but of aperture A_1 and A_2 ($A_2 < A_1$), are used as the objective lenses in two astronomical telescopes having identical eyepieces. What is the ratio of their resolving power ? Which telescope will you prefer and why ? Give reason.

2

13. Draw the output waveform at X, using the given inputs A and B for the logic circuit shown below. Also, identify the logic operation performed by this circuit.

2

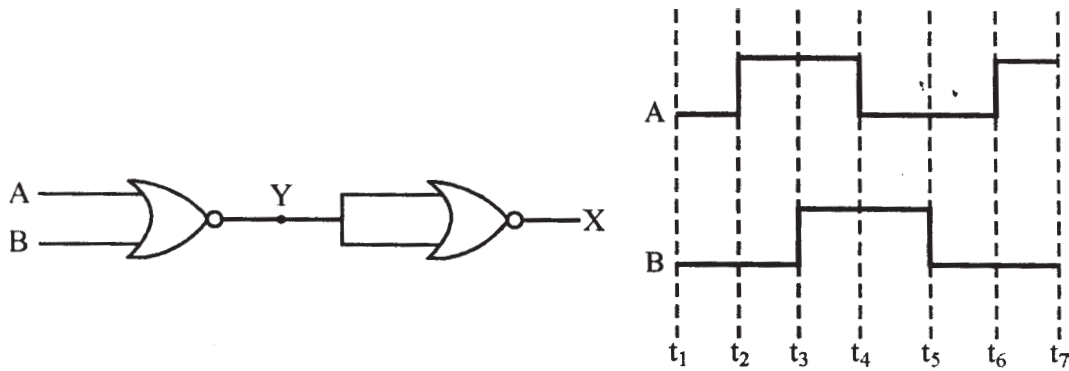

14. Name the semiconductor device that can be used to regulate an unregulated dc power supply. With the help of I-V characteristics of this device, explain its working principle. 2
15. How are infrared waves produced ? Why are these referred to as 'heat waves' ? Write their one important use. 2
16. Draw the transfer characteristic curve of a base biased transistor in CE configuration. Explain clearly how the active region of the V_0 versus V_i curve in a transistor is used as an amplifier. 2
17. (i) Define modulation index. 2
- (ii) Why is the amplitude of modulating signal kept less than the amplitude of carrier wave ?
18. A current is induced in coil C_1 due to the motion of current carrying coil C_2 . (a) Write any two ways by which a large deflection can be obtained in the galvanometer G. (b) Suggest an alternative device to demonstrate the induced current in place of a galvanometer. 2

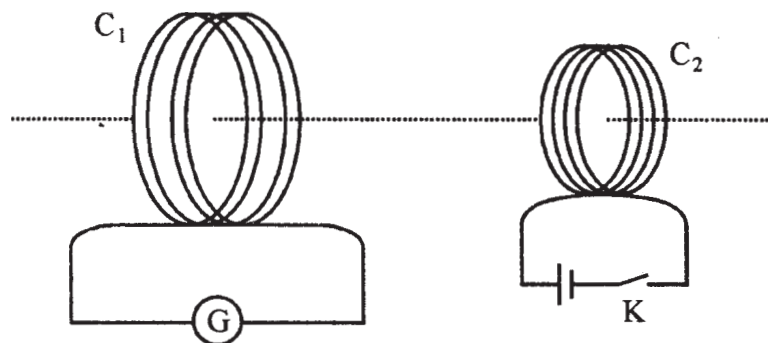

19. Define the terms (i) drift velocity, (ii) relaxation time. 3
- A conductor of length L is connected to a dc source of emf ϵ . If this conductor is replaced by another conductor of same material and same area of cross-section but of length $3L$, how will the drift velocity change ?
20. Using Gauss's law obtain the expression for the electric field due to a uniformly charged thin spherical shell of radius R at a point outside the shell. Draw a graph showing the variation of electric field with r , for $r > R$ and $r < R$. 3
21. An electron and a photon each have a wavelength 1.00 nm . Find 3
- (i) their momenta,
 - (ii) the energy of the photon and
 - (iii) the kinetic energy of electron.
22. Draw a schematic diagram showing the (i) ground wave (ii) sky wave and (iii) space wave propagation modes for em waves. 3
- Write the frequency range for each of the following:
- (i) Standard AM broadcast
 - (ii) Television
 - (iii) Satellite communication
23. Describe Young's double slit experiment to produce interference pattern due to a monochromatic source of light. Deduce the expression for the fringe width. 3

OR

Use Huygen's principle to verify the laws of refraction.

24. (a) Describe briefly, with the help of suitable diagram, how the transverse nature of light can be demonstrated by the phenomenon of polarization. 3
- (b) When unpolarized light passes from air to a transparent medium, under what condition does the reflected light get polarized ?
25. The energy levels of a hypothetical atom are shown below. Which of the shown transitions will result in the emission of a photon of wavelength 275 nm ? 3

Which of these transitions correspond to emission of radiation of (i) maximum and (ii) minimum wavelength?

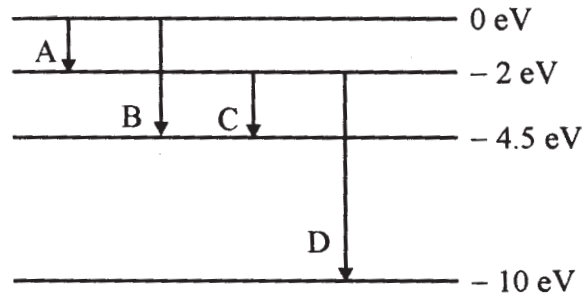

26. State the law of radioactive decay. 3

Plot a graph showing the number (N) of undecayed nuclei as a function of time (t) for a given radioactive sample having half life $T_{1/2}$.

Depict in the plot the number of undecayed nuclei at (i) $t = 3 T_{1/2}$ and (ii) $t = 5 T_{1/2}$.

27. In the circuit shown, $R_1 = 4 \Omega$, $R_2 = R_3 = 15 \Omega$, $R_4 = 30 \Omega$ and $E = 10 \text{ V}$. Calculate the equivalent resistance of the circuit and the current in each resistor. 3

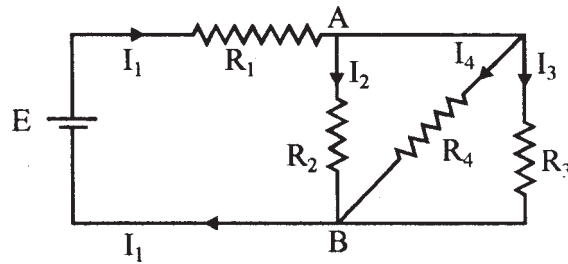

28. State Biot-Savart law, giving the mathematical expression for it. 5

Use this law to derive the expression for the magnetic field due to a circular coil carrying current at a point along its axis.

How does a circular loop carrying current behave as a magnet ?

OR

With the help of a labelled diagram, state the underlying principle of a cyclotron. Explain clearly how it works to accelerate the charged particles.

Show that cyclotron frequency is independent of energy of the particle. Is there an upper limit on the energy acquired by the particle ? Give reason.

29. (a) Draw a ray diagram to show refraction of a ray of monochromatic light passing through a glass prism. 5

Deduce the expression for the refractive index of glass in terms of angle of prism and angle of minimum deviation.

- (b) Explain briefly how the phenomenon of total internal reflection is used in fibre optics.

OR

- (a) Obtain lens makers formula using the expression

$$\frac{n_2}{v} - \frac{n_1}{u} = \frac{(n_2 - n_1)}{R}$$

Here the ray of light propagating from a rarer medium of refractive index (n_1) to a denser medium of refractive index (n_2) is incident on the convex side of spherical refracting surface of radius of curvature R.

- (b) Draw a ray diagram to show the image formation by a concave mirror when the object is kept between its focus and the pole. Using this diagram, derive the magnification formula for the image formed.

30. (i) With the help of a labelled diagram, describe briefly the underlying principle and working of a step up transformer. 5

- (ii) Write any two sources of energy loss in a transformer.

- (iii) A step up transformer converts a low input voltage into a high output voltage. Does it violate law of conservation of energy ? Explain.

OR

Derive an expression for the impedance of a series LCR circuit connected to an AC supply of variable frequency.

Plot a graph showing variation of current with the frequency of the applied voltage.

Explain briefly how the phenomenon of resonance in the circuit can be used in the tuning mechanism of a radio or a TV set.

QUESTION PAPER CODE 51/1

1. Define electric dipole moment. Write its S.I. unit. 1
2. Where on the surface of Earth is the angle of dip 90° ? 1
3. A hollow metal sphere of radius 5 cm is charged such that the potential on its surface is 10 V. What is the potential at the centre of the sphere? 1
4. How are radio waves produced ? 1
5. Write any two characteristic properties of nuclear force. 1
6. Two bar magnets are quickly moved towards a metallic loop connected across a capacitor 'C' as shown in the figure. Predict the polarity of the capacitor. 1

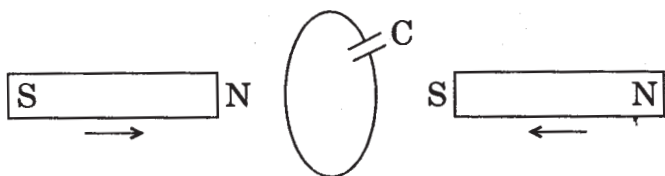

7. What happens to the width of depletion layer of a p-n junction when it is (i) forward biased, (ii) reverse biased ? 1
8. Define the term 'stopping potential' in relation to photoelectric effect. 1
9. A thin straight infinitely long conducting wire having charge density λ is enclosed by a cylindrical surface of radius r and length l , its axis coinciding with the length of the wire. Find the expression for the electric flux through the surface of the cylinder. 2
10. Plot a graph showing the variation of coulomb force (F) versus $\left(\frac{1}{r^2}\right)$; where r is the distance between the two charges of each pair of charges: $(1 \mu\text{C}, 2 \mu\text{C})$ and $(2 \mu\text{C}, -3 \mu\text{C})$. Interpret the graphs obtained. 2
11. Write the expression for Lorentz magnetic force on a particle of charge 'q' moving with velocity \vec{v} in a magnetic field \vec{B} . Show that no work is done by this force on the charged particle. 2

OR

A steady current (I_1) flows through a long straight wire. Another wire carrying steady current (I_2) in the same direction is kept close and parallel to the first wire. Show with the help of a diagram how the magnetic field due to the current I_1 exerts a magnetic force on the second wire. Write the expression for this force. 2

12. What are eddy currents ? Write any two applications of eddy currents. 2
13. What is sky wave communication ? Why is this mode of propagation restricted to the frequencies only upto few MHz ? 2
14. In the given circuit, assuming point A to be at zero potential, use Kirchhoff's rules to determine the potential at point B. 2

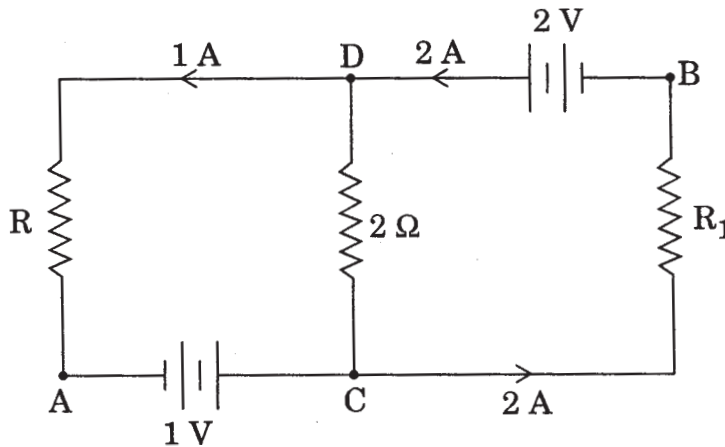

15. A parallel plate capacitor is being charged by a time varying current. Explain briefly how Ampere's circuital law is generalized to incorporate the effect due to the displacement current. 2
16. Net capacitance of three identical capacitors in series is $1 \mu\text{F}$. What will be their net capacitance if connected in parallel ?

Find the ratio of energy stored in the two configurations if they are both connected to the same source. 2

17. Using the curve for the binding energy per nucleon as a function of mass number A , state clearly how the release in energy in the processes of nuclear fission and nuclear fusion can be explained. 2

18. In the metre bridge experiment, balance point was observed at J with $AJ = l$.
- The values of R and X were doubled and then interchanged. What would be the new position of balance point ?
 - If the galvanometer and battery are interchanged at the balance position, how will the balance point get affected ?

2

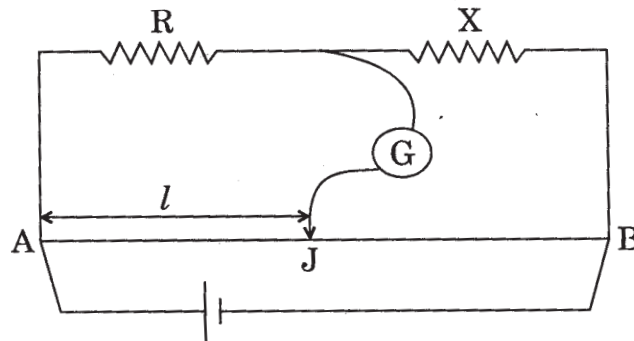

19. A convex lens made up of glass of refractive index 1.5 is dipped, in turn, in (i) a medium of refractive index 1.65, (ii) a medium of refractive index 1.33.
- Will it behave as a converging or a diverging lens in the two cases ?
 - How will its focal length change in the two media ?
20. Draw a plot showing the variation of photoelectric current with collector plate potential for two different frequencies, $\nu_1 > \nu_2$, of incident radiation having the same intensity. In which case will the stopping potential be higher ? Justify your answer.
21. Write briefly any two factors which demonstrate the need for modulating a signal.
Draw a suitable diagram to show amplitude modulation using a sinusoidal signal as the modulating signal.
22. Use the mirror equation to show that
- an object placed between f and $2f$ of a concave mirror produces a real image beyond $2f$.
 - a convex mirror always produces a virtual image independent of the location of the object.
 - an object placed between the pole and focus of a concave mirror produces a virtual and enlarged image.

3

3

3

3

23. Draw a labelled diagram of a full wave rectifier circuit. State its working principle. Show the input-output waveforms. 3
24. (a) Using de Broglie's hypothesis, explain with the help of a suitable diagram, Bohr's second postulate of quantization of energy levels in a hydrogen atom.
- (b) The ground state energy of hydrogen atom is -13.6 eV . What are the kinetic and potential energies of the electron in this state? 3
25. You are given a circuit below. Write its truth table. Hence, identify the logic operation carried out by this circuit. Draw the logic symbol of the gate it corresponds to. 3

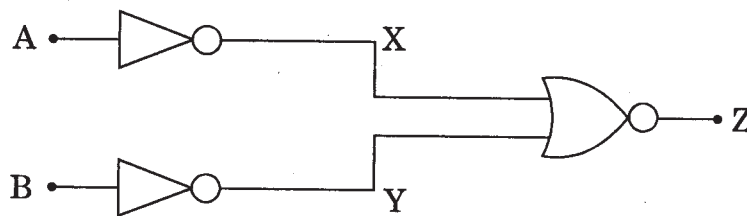

26. A compound microscope uses an objective lens of focal length 4 cm and eyepiece lens of focal length 10 cm . An object is placed at 6 cm from the objective lens. Calculate the magnifying power of the compound microscope. Also calculate the length of the microscope. 3

OR

A giant refracting telescope at an observatory has an objective lens of focal length 15 m . If an eyepiece lens of focal length 1.0 cm is used, find the angular magnification of the telescope.

If this telescope is used to view the moon, what is the diameter of the image of the moon formed by the objective lens? The diameter of the moon is $3.42 \times 10^6 \text{ m}$ and the radius of the lunar orbit is $3.8 \times 10^6 \text{ m}$. 3

27. Two heating elements of resistances R_1 and R_2 when operated at a constant supply of voltage, V , consume powers P_1 and P_2 respectively. Deduce the expressions for the power of their combination when they are, in turn, connected in (i) series and (ii) parallel across the same voltage supply. 3
28. (a) State the principle of the working of a moving coil galvanometer, giving its labelled diagram.

- (b) "Increasing the current sensitivity of a galvanometer may not necessarily increase its voltage sensitivity." Justify this statement.
- (c) Outline the necessary steps to convert a galvanometer of resistance R_G into an ammeter of a given range. 5

OR

- (a) Using Ampere's circuital law, obtain the expression for the magnetic field due to a long solenoid at a point inside the solenoid on its axis.
- (b) In what respect is a toroid different from a solenoid? Draw and compare the pattern of the magnetic field lines in the two cases.
- (c) How is the magnetic field inside a given solenoid made strong? 5

29. State the working of a.c. generator with the help of a labelled diagram.

The coil of an a.c. generator having N turns, each of area A , is rotated with a constant angular velocity ω . Deduce the expression for the alternating e.m.f. generated in the coil.

What is the source of energy generation in this device? 5

OR

- (a) Show that in an a.c. circuit containing a pure inductor, the voltage is ahead of current by $\pi/2$ in phase.
- (b) A horizontal straight wire of length L extending from east to west is falling with speed v at right angles to the horizontal component of Earth's magnetic field B .
- (i) Write the expression for the instantaneous value of the e.m.f. induced in the wire.
- (ii) What is the direction of the e.m.f.?
- (iii) Which end of the wire is at the higher potential? 5

30. State the importance of coherent sources in the phenomenon of interference.

In Young's double slit experiment to produce interference pattern, obtain the conditions for constructive and destructive interference. Hence deduce the expression for the fringe width.

How does the fringe width get affected, if the entire experimental apparatus of Young is immersed in water ?

5

OR

- (a) State Huygens' principle. Using this principle explain how a diffraction pattern is obtained on a screen due to a narrow slit on which a narrow beam coming from a monochromatic source of light is incident normally.
- (b) Show that the angular width of the first diffraction fringe is half of that of the central fringe.
- (c) If a monochromatic source of light is replaced by white light, what change would you observe in the diffraction pattern ?

5

Marking Scheme — Physics (Theory)

General Instructions :

1. The Marking Scheme provides general guidelines to reduce subjectivity in the marking. The answers given in the marking scheme are suggested answers. The content is thus indicative. If a student has given any other answer, which is different from the one given in the Marking Scheme, but conveys the meaning correctly, such answers should be given full weightage.
2. Evaluation is to be done as per instructions provided in the marking scheme. It should not be done according to one's own interpretation or any other consideration. Marking Scheme should be adhered to and religiously followed.
3. If a question has parts, please award marks in the right hand side for each part. Marks awarded for different part of the question should then be totalled up and written in the left hand margin and circled.
4. If a question does not have any parts, marks are to be awarded in the left hand margin only.
5. If a candidate has attempted an extra question, marks obtained in the question attempted first should be retained and the other answer should be scored out.
6. No marks are to be deducted for the cumulative effect of an error. The student should be penalized only once.
7. Deduct $\frac{1}{2}$ mark for writing wrong units, missing units, in the final answer to numerical problems.
8. Formula can be taken as implied from the calculations even if not explicitly written.
9. In short answer type questions, asking for two features/characteristics/ properties, if a candidate writes three features, characteristics/properties or more, only the correct two should be evaluated.
10. Full marks should be awarded to a candidate if his/her answer in a numerical problem, is close to the value given in this scheme.

QUESTION PAPER CODE 55/1/1

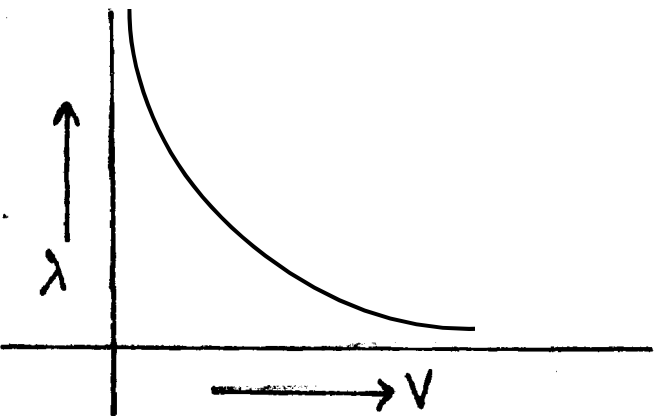
Q. No.	Expected Answer/value Points	Marks	Total Marks
1.	(i) Positive	1/2	
	(ii) Negative	1/2	1
2.	\vec{E} along X-axis, \vec{B} along Y-axis	1/2+1/2	
	Alternatively, \vec{E} along Y-axis, \vec{B} along X-axis		1
3.	$r = R \left\{ \frac{E}{V} - 1 \right\}$	1	1
4.	Diamagnetic	1	
	Alternatively, Ferromagnetic (if the given value is considered as absolute permeability) (Accept either of the two)		1
5.		1	
6.	Collector current decreases slightly	1/2	
	Base current increases slightly	1/2	1

7. Current flowing in a circuit without any net dissipation of power, is called wattless current. 1 1

8. Atoms (of the second medium) oscillate with the same (incident light) frequency and in turn, emit light of the same frequency.

Alternatively,

Frequency of light may be viewed as a property of the source and not of the medium.

Alternatively,

From Huygen's principle, we find that $\frac{v_1}{\lambda_1} = \frac{v_2}{\lambda_2} = n$

Hence frequency remains the same. 1 1

9	Depiction of equipotential surface	1
	Magnitude of electric field	1/2
	Direction of electric field	1/2

Depiction of equipotential surface
(Parallel to the X - Z plane) 1

$qE = mg$ 1/2

$\Rightarrow E = \frac{mg}{q}$: direction vertically downwards 1/2

OR

Resultant dipole moment	1
Magnitude of torque	1/2
Direction of torque	1/2

Resultant dipole moment = p

The magnitude of torque is $pE \sin 30^\circ = \frac{pE}{2}$ 1

The direction of torque is clockwise when viewed from above 1/2

(or $\vec{\tau}$ is perpendicular to both \vec{P} and \vec{E}). 1/2 2

10.	Formula	1		
	Substitution and Calculation of B	1		
	$B_H = B \cos \theta$		1	
	$B = \frac{B_H}{\cos 60^\circ} = 0.8 \text{ G}$		1	2
11.	Formula	1		
	Conclusions about C_1 and C_2	1		
	P.D. across $C_1 = 6\text{V}$		$\frac{1}{2}$	
	Final charge on $C_1 = 18\mu\text{C}$		$\frac{1}{2}$	
	P.D. across $C_2 = 2\text{V}$		$\frac{1}{2}$	
	Final charge on $C_2 = 6\mu\text{C}$		$\frac{1}{2}$	
	Alternatively,			
	$Q = CV$		$\frac{1}{2}$	
	$C' = KC$		$\frac{1}{2}$	
	Across C_1 , V remains same but charge increases		$\frac{1}{2}$	
	Across C_2 , charge Q remains same but p.d. decreases		$\frac{1}{2}$	2
12.	Ratio	1		
	Preference	$\frac{1}{2}$		
	Reason	$\frac{1}{2}$		
	Ratio of resolving power = $\frac{A_1}{A_2}$		1	
	Telescope of aperture A_j is preferred		$\frac{1}{2}$	
	Reason: (Any one)			
	Higher resolving power / More light gathering power		$\frac{1}{2}$	2

13.	Correct output wavefonn	1
	Identification	1

Drawing correct output waveform

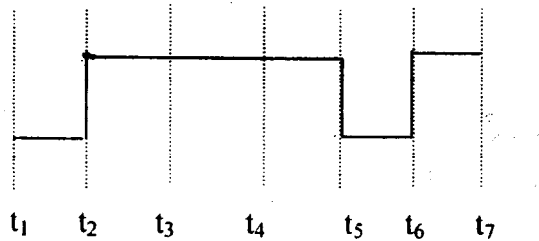

1

OR gate

1

(However if the output wavefonn is drawn wrong but the student correctly identifies the logic operation (according to the output wavefonn drawn) award 1 mark only)

2

14.	Naming of Device	1/2
	I- V characteristic	1/2
	Working principle	1

Zener diode

1/2

Alternatively



I- V characteristic

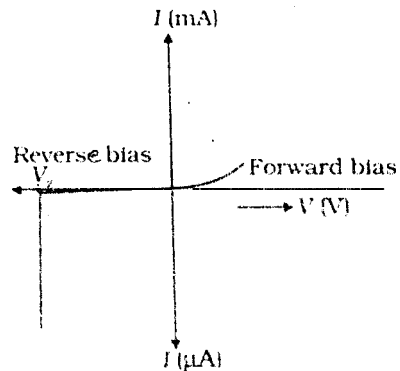

1/2

After the breakdown voltage, there is an insignificant change in the (reverse) bias voltage across the Zener diode (and hence the load) even for large changes in current.

1

2

15.	Production	1
	Reason	1/2
	Any one use	1/2

Method of production (any one)

1

by hot bodies and molecules /

due to vibrations of atoms and molecules /

due to transition of electrons between two (closely spaced)

energy levels in an atom.

Infrared waves are called heat waves as they cause heating effect / rise in temperature

1/2

Any one use

Maintains earth's warmth, physical therapy, remote switches etc. or any other correct use

1/2

2

16.	Graph	1
	Explanation	1

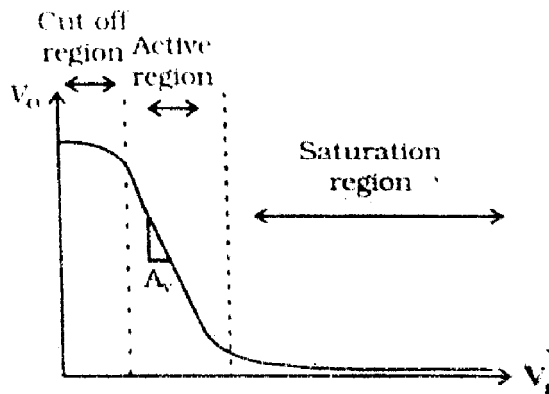

1

(Award one mark even if the student does not label the three regions)

In the active region, a (small) increase of V_i results in a (large, almost linear) increase in I_c . This results in an increase in the voltage drop across R_c .

[Note: The student may be awarded this 1 mark even if she/he gives a (brief) explanation of the transistor amplifier action without any reference to the transfer characteristic]

2

17.	Modulation index	1
	Reason	1

Modulation index is defined as the ratio of amplitude of modulating signal and amplitude of carrier wave

Alternatively,

$$\mu = \frac{A_m}{A_c} \quad 1$$

The amplitude of modulating signal is kept less than amplitude of carrier wave to avoid/ minimize distortion / noise. 1 2

18.	Any two ways	1
	Alternative device	1

Any two ways to obtain large deflection in G 1/2+1/2

Moving C_2 faster towards C_1 / Increasing current in C_2 /

Insertion of soft iron core in C_1 /

Increasing number of turns of C_1 /

Increasing area of cross section of C_1

Alternative device (any one)

Bulb / LED / Compass needle / any other device responsive to (small) current. 1 2

19.	Drift velocity	1
	Relaxation time	1
	Change in drift velocity	1

Drift velocity: The average velocity with which the free electrons drift under the influence of an external field. 1

Relaxation Time: Average time interval between two successive collisions of an electron with the ions / atoms of the conductor. 1

The drift velocity will be inversely proportional to I (or $v_d \propto \frac{1}{I}$) and hence it will become one third of its initial value 1

Alternatively,

$$V_d' = \frac{v_d}{3}$$

[Note: If the candidate directly writes $\frac{v_d}{3}$ without giving any reason, award one mark] 3

20.	Obtaining the field expression	2
	Graph	1

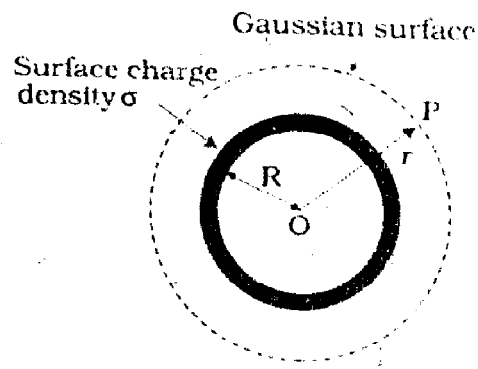

1/2

From Gauss's theorem, $f = \oint_s \vec{E} \cdot d\vec{S} = \frac{q_m}{\epsilon_0}$ 1/2

Flux f through S' . 1/2

$$f = \oint_{s'} \vec{E} \cdot d\vec{S} = \oint_{s'} E dS = E \cdot 4\pi r^2$$
 1/2

$$\Rightarrow E \cdot 4\pi r^2 = \frac{q_m}{\epsilon_0} \Rightarrow E = \frac{1}{4\pi\epsilon_0} \frac{q_m}{r^2} \quad \frac{1}{2}$$

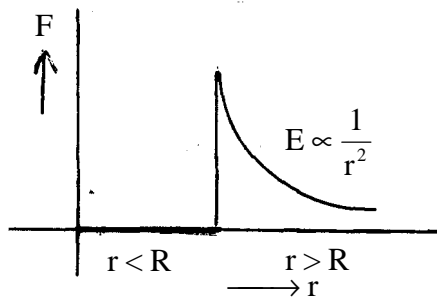

$\frac{1}{2} + \frac{1}{2}$

[Note: $\frac{1}{2}$ mark for $r < R$ and $\frac{1}{2}$ mark for $r > R$]

3

21	Momenta	1
	Energy of photon	1
	Kinetic energy of electron	1

$$\lambda_e = \lambda_{\text{photon}} = 1.00\text{nm} = 10^{-9}\text{ m}$$

i) for electron or photon, momentum $p = p_e = p_r = \frac{h}{l}$ $\frac{1}{2}$

$$p = \frac{(6.63 \times 10^{-34})}{10^{-9}} = 6.63 \times 10^{-25}\text{ kg m/s} \quad \frac{1}{2}$$

ii) Energy of photon

$$E = \frac{hc}{l}$$

$$= \frac{(6.63 \times 10^{-34}) \times (3 \times 10^8)}{10^{-9}}\text{ J} \quad \frac{1}{2}$$

$$\approx 19.89 \times 10^{-17}\text{ J} (\approx 1243\text{ eV})$$

iii) Kinetic energy of electron = $\frac{p^2}{2m}$ $\frac{1}{2}$

$$= \frac{1}{2} \times \frac{(6.63 \times 10^{-25})^2 \times (3 \times 10^8)}{9.1 \times 10^{-31}}\text{ J} \approx 2.42 \times 10^{-19}\text{ J} \quad \frac{1}{2}$$

$$(\approx 1.51\text{eV}) \quad \frac{1}{2}$$

3

S is the source of monochromatic light of wavelength λ .

The double slits S_1 and S_2 act as the two coherent sources. 1/2

Let $x = S_2P - S_1P$

$$S_2P^2 = D^2 + (y + d/2)^2$$

and $S_1P^2 = D^2 + (y - d/2)^2$ 1/2

$$\therefore S_2P^2 - S_1P^2 = (y + d/2)^2 - (y - d/2)^2$$

$$\Rightarrow (S_2P + S_1P)(S_2P - S_1P) = 2y.d$$

$$\Rightarrow (S_2P + S_1P)x = 2yd$$

$$\Rightarrow x = \frac{2yd}{(S_2P + S_1P)} \approx \frac{2yd}{2D} = \frac{yd}{D}$$
 1/2

For maxima: $x = n\lambda \Rightarrow y = \frac{n\lambda D}{d}$ ($n = 0, 1, 2, \dots$) 1/2

\therefore Fringe width $\beta = y_{n+1} - y_n = \frac{\lambda D}{d}$ 1/2

[Note: Alternatively, if the student uses the condition for minima, award the last (1/2 + 1/2) marks]

3

OR

Diagram	1
Verification	1

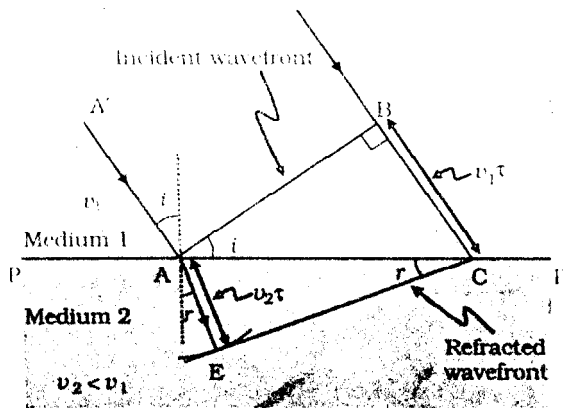

In ΔABC , $\sin i = \frac{BC}{AC} = \frac{v_1 t}{AC}$ 1/2

and in ΔADC , $\sin r = \frac{AD}{AC} = \frac{v_2 t}{AC}$ 1/2

$$\frac{\sin i}{\sin r} = \left(\frac{v_1 t / AC}{v_2 t / AC} \right) = \frac{v_1}{v_2} = \text{constant} = (\text{relative}) \text{ refractive index} \quad 1$$

[Note: The student can also draw the diagram for light going from denser to rarer medium and use that for verification of the law of refraction] 3

24.	a) Diagram	1
	Description	1
	b) Condition	1

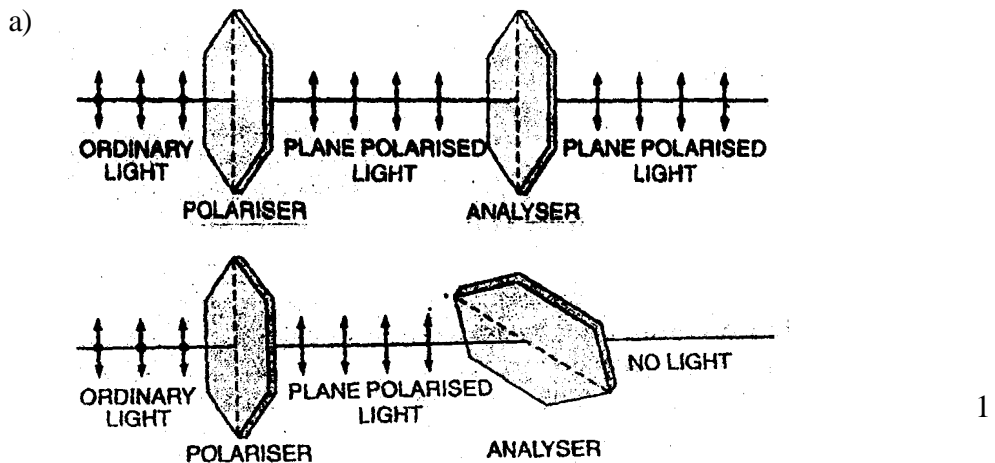

When a polaroid P_1 is rotated in the path of an unpolarised light. there is no change in transmitted intensity.

The light transmitted through polaroid P_1 is made to pass through polaroid P_2 .

On rotating polaroid P_2 in path of light transmitted from P_1 we notice a change in intensity of transmitted light. This shows that light transmitted from P_1 is polarized. Since light can be polarized, it has transverse nature. 1

[Note: Award full marks even if the student explains with the help of only one diagram]

(b) Whenever the reflected and refracted rays are perpendicular to each other. 1

Alternatively,

Whenever unpolarised light is incident from air to a transparent medium at an angle of incidence equal to polarizing angle, the reflected light gets polarized.

3

25.	$E=hc/\lambda$	1/2 mark
	Calculation of E	1 mark
	Identification of correct transition	1/2 mark
	Transition for maximum wavelength	1/2 mark
	Transition for minimum wavelength	1/2 mark

If a photon of wavelength $\lambda = 275\text{nm}$ is to be emitted. then energy of photon is given by

$$E = \frac{hc}{\lambda} \quad \frac{1}{2}$$

$$= \frac{6.63 \times 10^{-34} \times 3 \times 10^8}{275 \times 10^{-9} \times 1.6 \times 10^{-19}} \text{ eV} \quad \frac{1}{2}$$

$$= 4.5 \text{ eV} \quad \frac{1}{2}$$

Hence transition B would result in the emission of a photon of wavelength 275nm 1/2

(i) Transition A corresponds to maximum wavelength 1/2

(ii) Transition D corresponds to minimum wavelength 1/2

3

26	Statement of law	1
	Graph	1
	Depiction for time $t = 3 T_{1/2}$ and $T = 5 T_{1/2}$,	1/2+1/2

The number of nuclei undergoing decay per unit time, at any instant, is proportional to the total number of nuclei in the sample at that instant. 1

Alternatively

$$-\frac{dN}{dt} = \lambda N$$

$$\Rightarrow \frac{dN}{dt} = -\lambda N$$

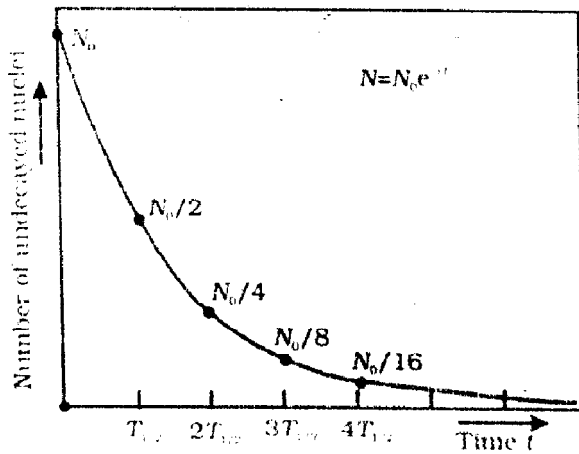

1+1

[Note: The student is to mark the two point only for $t = 3T_{1/2}$ and $t = 5T_{1/2}$.]

3

27	Equivalent resistance	1
	Calculation of I_1	$\frac{1}{2}$
	Calculation of I_2	$\frac{1}{2}$
	Calculation of I_3	$\frac{1}{2}$
	Calculation of I_4	$\frac{1}{2}$

R_2, R_3 and R_4 are in parallel.

$$\frac{1}{R_{234}} = \frac{1}{15} + \frac{1}{30} + \frac{1}{15} = \frac{3+1+2}{30} = \frac{5}{30}$$

$$\Rightarrow R_{234} = 6 \Omega$$

$\frac{1}{2}$

Now R_{234} is in series with R_1 , so $R_{eq} = 4 \Omega + 6 \Omega = 10 \Omega$

$\frac{1}{2}$

$$\therefore I = \frac{\epsilon}{R_{eq}} = \frac{10}{10} \text{ A} = 1 \text{ A}$$

$$\therefore I_1 = 1 \text{ A}$$

$$\therefore \text{Current through } R_1 = 1 \text{ A}$$

$\frac{1}{2}$

$$\text{P.D. across } R_1 = 4 \text{ V}$$

$$\text{So, P.D. across } R_{234} = 6 \text{ V}$$

$$\therefore I_2 R_2 = I_4 R_4 = I_3 R_3 = 6V$$

$$I_2 = \frac{6}{15} A = 0.4 A \quad \frac{1}{2}$$

$$I_3 = \frac{6}{15} A = 0.4 A \quad \frac{1}{2}$$

$$I_4 = \frac{6}{30} A = 0.2 A \quad \frac{1}{2}$$

3

28.	Biot Savart Law	1
	Derivation	3
	Explanation	1

Statement of Biot Savart Law : The magnitude of magnetic field $d\vec{B}$ due to current element is directly proportional to the current I , the element length $|dl|$ and inversely proportional to the square of the distance r of the field point. Its direction is perpendicular to the plane containing $d\vec{l}$ and \vec{r} 1/2

$$d\vec{B} \propto \frac{I d\vec{l} \times \vec{r}}{r^3}$$

$$\text{Or } d\vec{B} = \frac{\mu_0}{4\pi} \frac{I d\vec{l} \times \vec{r}}{r^3} \quad \frac{1}{2}$$

[Note: Even if the student writes only the (vector) mathematical expression, award this one mark]

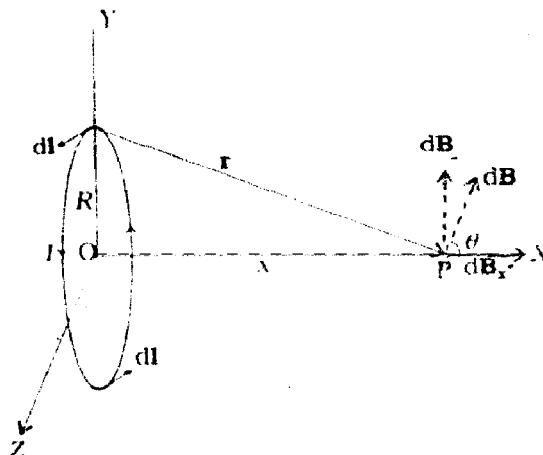

1

The magnetic field due to $d\vec{l}$ is given by Biot Savart law as

$$dB = \frac{\mu_0}{4\pi} \frac{I |d\vec{l} \times \vec{r}|}{r^3}$$

$$\text{Now } dB_x = dB \cos\theta = \frac{\mu_0}{4\pi} \frac{Idl}{(x^2 + R^2)} \cos\theta$$

$$= \frac{\mu_0}{4\pi} \frac{Idl}{(x^2 + R^2)} \frac{R}{(x^2 + R^2)^{1/2}}$$

1

$$\text{So } B_x = \int dB_x = \frac{\mu_0}{4\pi} \frac{IR}{(x^2 + R^2)^{3/2}} \int_{\text{entire loop}} dl$$

$$= \frac{\mu_0}{4\pi} \frac{IR}{(x^2 + R^2)^{3/2}} 2\pi R$$

$$= \frac{\mu_0 IR^2}{2(x^2 + R^2)^{3/2}}$$

(The y-components, of the field, add up to zero, due to symmetry)

∴ Magnetic field at P due to a circular loop

$$= \vec{B} = B_x \vec{i} = \frac{\mu_0 IR^2}{2(x^2 + R^2)^{3/2}} \vec{i}$$

1

[Note: Also accept if the student writes $\vec{B} = \frac{\mu_0 NIR^2}{2(x^2 + R^2)^{3/2}} \vec{i}$]

Explanation : A circular current loop produces magnetic field and its magnetic moment is the product of current and its area

$$\vec{M} = I\vec{A}$$

Alternatively

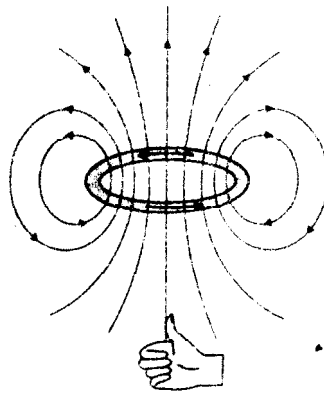

Alternatively : One side of the current carrying coil behaves like the N-Pole and the other side as the S-Pole of a magnet.

1

5

OR

Labelled diagram	1
Principle	1
Working	1
Proof of frequency independent from energy	1
Yes	1/2
Reason	1/2

Principle: A charged particle can be accelerated to high energy by making it cross the same electric field again and again using a perpendicular magnetic field.

1

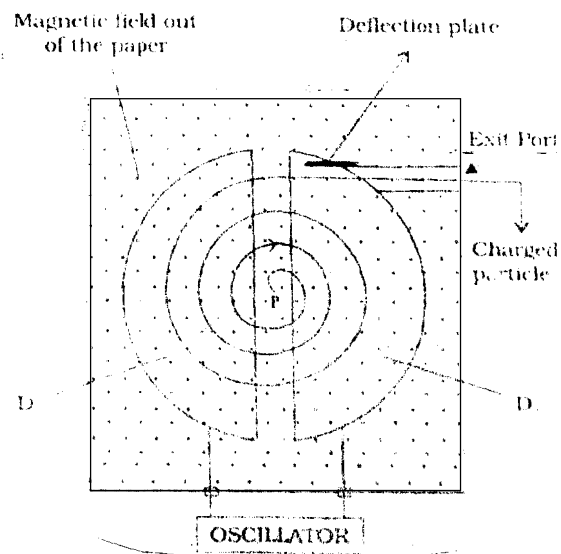

1

Working : High frequency oscillator maintains modest alternating potential difference between the dees. This potential difference establishes an electric field that reverses its direction periodically. Suppose a positive ion of moderate mass produced at the centre of the dees, finds D_2 at negative potential. It gets accelerated towards it. A uniform magnetic field, normal to the plane of the dees, makes it move in a circular track. Particle traces a semicircular track and returns back to the region between the dees. The moment it arrives in the region, electric field reverses its direction and accelerates the charge towards D_1 . This way charge keeps on getting accelerated until it is removed out of the dees.

1

Centripetal force, needed by the charged particle to move in circular track, is provided by the magnetic field.

$$\frac{mv^2}{r} = qvB$$

$$\Rightarrow v = \frac{qBr}{m}$$

$$\begin{aligned} \text{Period of revolution, } T &= \frac{2\pi r}{v} \\ &= \frac{2\pi m}{qB} \end{aligned}$$

$$\Rightarrow T = \frac{2\pi m}{qB} \quad \Rightarrow v = \frac{1}{T} = \frac{qB}{2\pi m}$$

Thus frequency of revolution ν is independent of the energy of the particle. 1

Yes, there is an upper limit on the energy acquired by the charged particle. $\frac{1}{2}$

The charged particle gains maximum speed when it moves in a path of radius equal to the radius of the dees.

i.e. $V_{\max} = \frac{qBR}{m}$ where R = radius of the dees.

$$\text{So maximum K.E.} = \frac{1}{2} mv_{\max}^2 = \frac{1}{2} m \left(\frac{qBR}{m} \right)^2 = \frac{q^2 B^2 R^2}{2m} \quad \frac{1}{2}$$

5

29.	a) Diagram	1
	Derivation of expression for the refractive index	2
b)	Explanation	2

a.

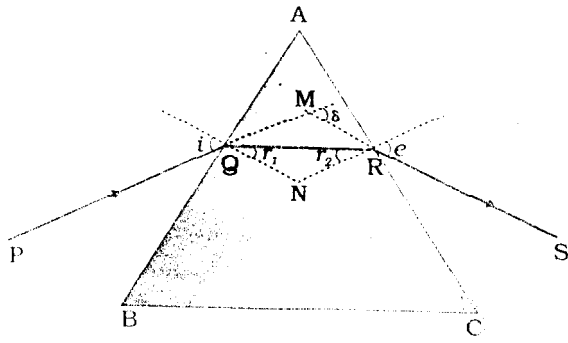

1

From ΔMQR , $(i-r_1) + (e-r_2) = d$

$\frac{1}{2}$

$$\text{So } (i+e) - (r_1 + r_2) = d$$

From ΔPQN $r_1 + r_2 + \angle QNR = 180^\circ$

Also $A + \angle QNR = 180^\circ$

Thus $A = r_1 + r_2$

$\frac{1}{2}$

So $i + e - A = d$

$\frac{1}{2}$

At minimum deviation, $i = e$, $r_1 = r_2 = r$ and $d = d_m$

$$\Rightarrow i = \frac{A + \delta_m}{2}$$

$$\text{and } r = \frac{A}{2}$$

$$\text{Also } \mu = \frac{\sin i}{\sin r}$$

$$\text{Hence } \mu = \frac{\sin\left(\frac{A + \delta_m}{2}\right)}{\sin\left(\frac{A}{2}\right)}$$

b.

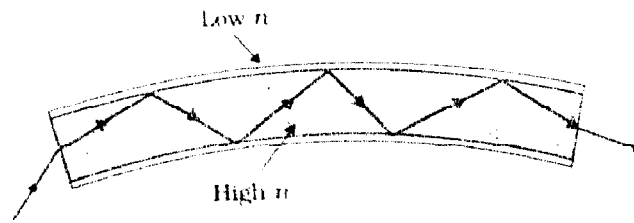

1

Each optical fibre consists of a core and cladding. Refractive index of the material of the core is higher than that of cladding. When a signal, in the form of light, is directed into the optical fibre, at an angle greater than the (relevant) critical angle, it undergoes repeated total internal reflections along the length of the fibre and comes out of it at the other end with almost negligible loss of intensity.

1

5

OR

a)	Diagram	1
	Derivation of Lens Maker's formula	2
b)	Diagram	1
	Derivation	1

a)

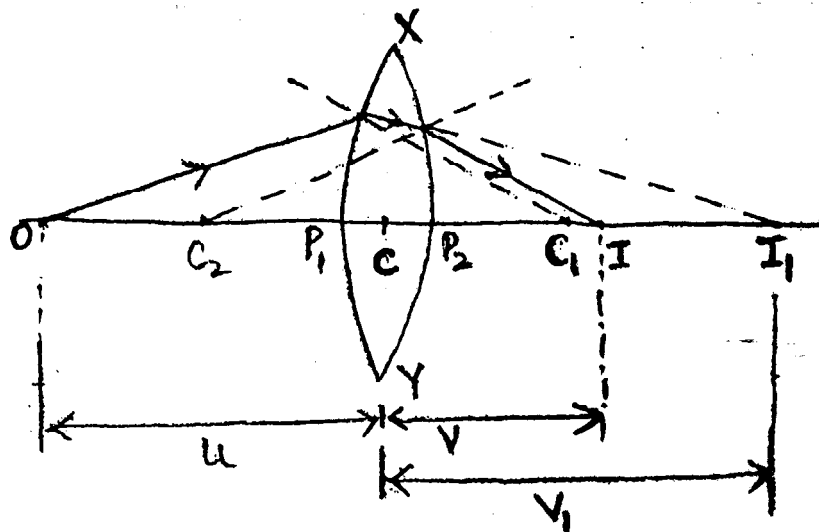

1

For refraction at the first surface

$$\frac{n_2}{v_1} - \frac{n_1}{u} = \frac{n_2 - n_1}{R_1}$$

1/2

For the second surface, I_1 acts as a virtual object (located in the denser medium) whose final real image is formed in the rarer medium at I.

So for refraction at this surface, we have

$$\frac{n_1}{v} - \frac{n_2}{v_1} = \frac{n_1 - n_2}{R_2} \quad \frac{1}{2}$$

From above two equations, $\frac{1}{v} - \frac{1}{u} = \left(\frac{n_2}{n_1} - 1\right) \left(\frac{1}{R_1} - \frac{1}{R_2}\right)$

The point, where image of an object, located at infinity is formed, is called the focus F, of the lens and the distance f gives its focal length. 1/2

So for $u = \infty$, $v = +f$

$$\Rightarrow \frac{1}{f} = \left(\frac{n_2}{n_1} - 1\right) \left(\frac{1}{R_1} - \frac{1}{R_2}\right) \quad \frac{1}{2}$$

b.

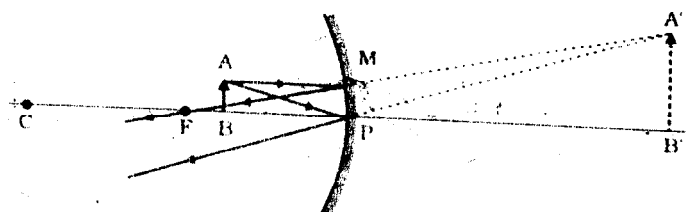

ΔABP is similar to $\Delta A'B'P$

So $\frac{A'B'}{AB} = \frac{B'P}{BP}$ 1/2

Now $A'B' = I$, $AB = O$, $B'P = +v$ and $BP = -u$

So magnification $m = \frac{I}{O} = -\frac{v}{u}$ 1/2

5

30.	Diagram	1/2
	Labelling	1/2
	Principle	1/2
	Working	1 1/2
	Two sources of energy loss	1/2+1/2
	No	1/2
	Explanation	1/2

Step up transformer

Any one of the following:

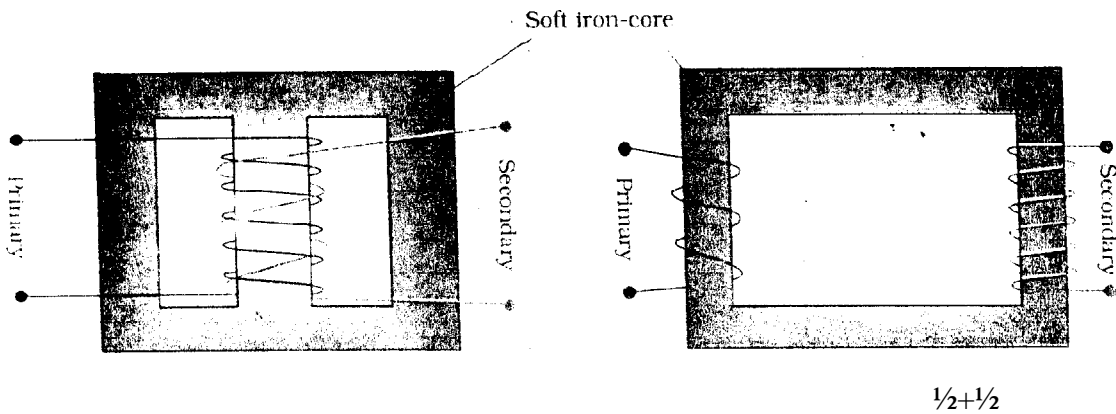

Principle: It works on the principle of mutual induction.

1/2

Working: When an alternating voltage is applied to the primary, the resulting current produces an alternating magnetic flux which links the secondary and induces an emf in it. We consider an ideal transformer in which the primary has negligible resistance and all the flux in the core links with both primary and secondary windings. Let ϕ be the flux in each turn in the core at time t due to current in the primary when a voltage V_p is applied to it.

Then the induced emf or voltage E_s , in the secondary with N_s , turns is

$$E_s = -N_s \frac{d\phi}{dt}$$

The alternating flux ϕ also induces an emf, called back emf in the primary given by

$$E_p = -N_p \frac{d\phi}{dt}$$

1/2

But $E_p = V_p$ (since resistance of primary is small) and $E_s = V_s$ (since secondary current is small)

$$\text{So, } V_s = -N_s \frac{d\phi}{dt}$$

$$V_p = -N_p \frac{d\phi}{dt}$$

$$\text{Thus } \frac{V_s}{V_p} = \frac{N_s}{N_p}$$

1/2

For a step up transformer, $\frac{V_s}{V_p} > 1$

So, $\frac{V_s}{V_p} > 1$ 1/2

(ii) Sources of energy loss in transformer (any two) 1/2+1/2
 flux leakage / Joule's loss in the resistance of windings /
 loss due to eddy currents / hysteresis loss / humming loss

(iii) No 1/2

A step up transformer steps up the voltage while it steps down the current.
 So the input and output power remain same (provided there is no loss).
 Hence there is no violation of the principle of energy conservation. 1/2

5

OR

Phasor diagram	1
Derivation of expression for impedance	2
Graph	1
Explanation	1

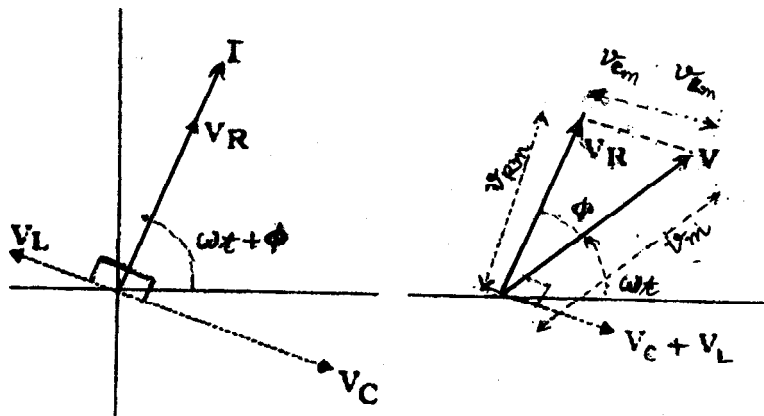

1

Let V_L , V_R , V_C and V represent the voltage across the inductor, resistor, capacitor and the source respectively. V_R is parallel to I . V_C is $\pi/2$ behind I and V_L is $\pi/2$ ahead of I .

Now $V_{OR} = V_{OC} = i_0 X_C$ and $V_{OL} = I_0 X_L$ 1/2

Clearly, $V_0^2 = V_{OR}^2 + (V_{OL} - V_{OC})^2$
 $= i_0^2 [R^2 + (X_L - X_C)^2]$ 1/2

Thus $i_0 = \frac{V_0}{\sqrt{R^2 + (X_L - X_C)^2}}$ 1/2

Impedance = $\frac{V_0}{i_0} = \sqrt{R^2 + (X_L - X_C)^2}$
 $= \sqrt{R^2 + \left(\omega L - \frac{1}{\omega C}\right)^2}$ 1/2

[**Alternatively** : Accept Impedance Triangle Method]

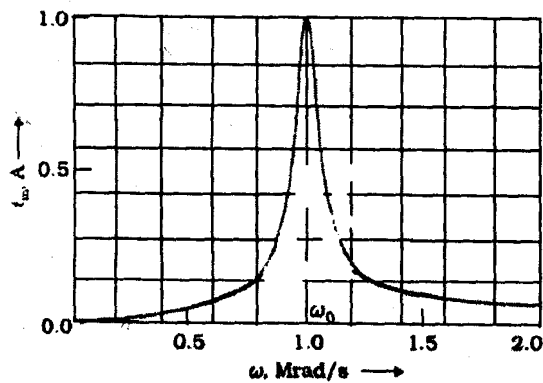

The capacitance of a capacitor in the tuning circuit is varied such that the resonant frequency of the circuit becomes nearly equal to the frequency of the radio signal to be received. When this happens, the amplitude of the current becomes maximum in the receiving circuit. 1 5

QUESTION PAPER CODE 55/1

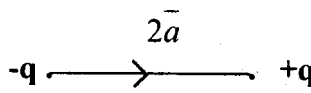
Q. No.	Expected Answer/value Points	Marks	Total Marks
1.	Electric dipole moment is defined as the numerical product of charge and distance between the charges, and is directed from negative to positive charge.	1/2	
	Alternatively		
			
	$\vec{p} = q(2\vec{a})$		
	Unit: coulomb metre or Cm	1/2	1
2.	Magnetic pole or Pole (If geographic pole is written award 1/2 Mark.)	1	1
3.	10 V (If formula alone is written as $V = \frac{Kq}{r}$ then give 1/2 Mark)	1	1
4.	Accelerated motion of charges in conducting wires Alternatively Rapid acceleration and deceleration of electrons in aerials Alternatively LC circuit Alternatively oscillating charge	1	1
5.	Short ranged, strong, attractive, charge independent, spin dependent, does not obey inverse square law, saturated, non central (Any two)	1/2+1/2	1

6.	Upper plate is positive and lower plate is negative.	1					
	Alternatively						
	Upper plate is negative and lower plate is positive (because axis is not given)						
	Alternatively						
	Accept diagrammatic answer also		1				
7.	(i) (slightly) decreases	1/2					
	(ii) (slightly) Increases	1/2					
	(Even if the student misses the word "slightly" award full marks.)		1				
8.	Stopping potential is the minimum negative(retarding) potential of anode for which photo current stops or becomes zero.	1	1				
9.	<table border="0" style="width: 100%;"> <tr> <td style="width: 60%;">Evaluation of charge enclosed</td> <td style="text-align: right;">1</td> </tr> <tr> <td>Evaluation of flux</td> <td style="text-align: right;">1</td> </tr> </table>			Evaluation of charge enclosed	1	Evaluation of flux	1
Evaluation of charge enclosed	1						
Evaluation of flux	1						
	Charge enclosed by the cylindrical surface $q = l \lambda$	1					
	Flux $\phi = \frac{q}{\epsilon_0}$	1/2					
	$= \frac{\lambda l}{\epsilon_0}$	1/2					
	Alternatively,						
	$\phi = \oint \mathbf{E} \cdot d\mathbf{S} = \frac{q}{\epsilon_0}$	1					
	$\phi = \frac{\lambda l}{\epsilon_0}$	1	2				
10.	<table border="0" style="width: 100%;"> <tr> <td style="width: 40%;">Each graph</td> <td style="text-align: right;">1/2+1/2</td> </tr> <tr> <td>Interpretation</td> <td style="text-align: right;">1/2+1/2</td> </tr> </table>			Each graph	1/2+1/2	Interpretation	1/2+1/2
Each graph	1/2+1/2						
Interpretation	1/2+1/2						

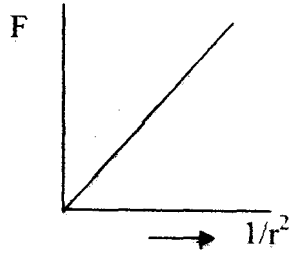

1/2

Repulsive

1/2

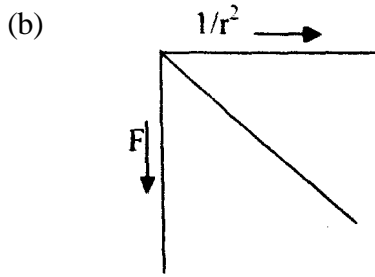

1/2

Attractive

1/2

Alternatively

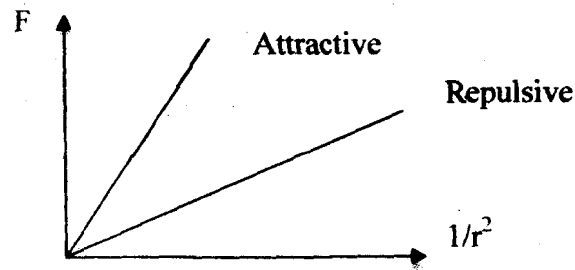

1/2+1/2

1/2+1/2

(Attractive force is greater than repulsive force since magnitude of the slope is more for attraction.)

2

11.

Expression for force	1
Work done is zero	1

$$\vec{F} = q(\vec{v} \times \vec{B})$$

1

Alternatively

$$\vec{F} = qvB \sin \theta \hat{n}$$

(If a student writes only magnitude for force i.e. $F = Bqv \sin \theta$ award 1/2 mark only)

Work done = $\vec{F} \cdot \vec{S}$ 1/2

as \vec{F} is perpendicular to \vec{S} , $W = 0$ 1/2

Alternatively

(Award this 1 mark even if the student gives correct work done)

2

OR

Diagram	1
Expression for force	1

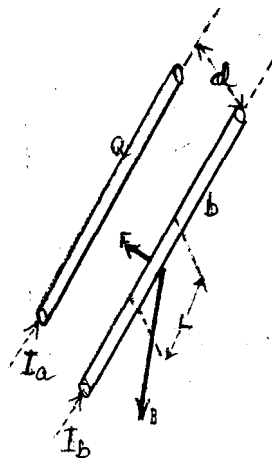

1

$F_{21} = I_2 l B_1$

1/2

$F_{21} = \frac{\mu_0 I_1 I_2}{2\pi d} l$

1/2

Alternatively

(If a student directly writes $F_{21} = \frac{\mu_0 I_1 I_2}{2\pi d} l$ award this 1 Mark)

2

12.

Definition	1
Two applications	1/2+1/2

When a bulk piece of conductor is subjected to changing magnetic flux, the induced currents, developed in it is called Eddy current.

1

Any two uses:

1/2+1/2

- 1 Magnetic brakes in trains
- 1 Electromagnetic damping

		Induction furnaces		
		Electric power meter		
		Induction therapy		
		To find the melting point of precious metals		
		In speedometer of vehicles.		2
13.	Sky wave Communication		1	
	Reason		1	
		Inospheric reflection of radio waves, back towards the earth, is known as sky wave communication.		1
		The ionospheric layers act as a reflector for a certain range of frequencies (3-30 MHz.)		
		Electromagnetic waves of frequencies higher than 30MHz (or few MBz) penetrate the ionosphere and escape.		1
		Alternatively		
		Diagrammatic explanation		2
				2
14.	Calculation of potential at B		2	
		Current division applying Kirchoffs law		1/2
		Along the path ACDB,		
		$V_B = 1 + 2(1) - 2 = 1$ volt		1 1/2
		Alternatively		
		Finding the current through CD alone		1/2
		Writing any two correct loop equations		1/2+1/2
		Calculations		1/2
				2
15.	Ampere's circuital law		2	
	Inconsistency		1/2	
	Introduction of displacement current		1/2	

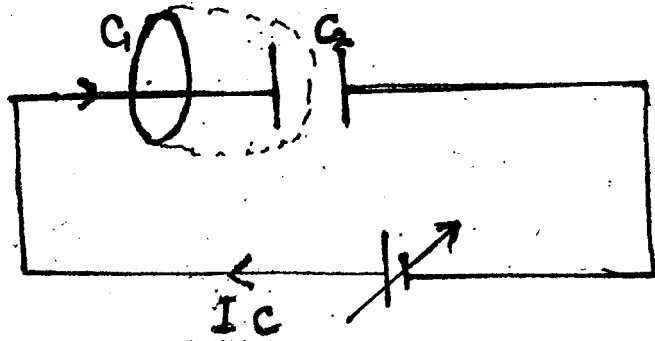

According to Ampere's circuital law, $\oint \vec{B} \cdot d\vec{l} = \mu_0 I_{en}$ 1/2

For C_1 $\oint \vec{B} \cdot d\vec{l} = \mu_0 I_{en}$

For C_2 $\oint \vec{B} \cdot d\vec{l} = 0$ 1/2

There is an inconsistency in Ampere's circuital law. To explain this displacement current was incorporated. 1/2

Using Ampere's law, we find different values of B for the two loops. 1/2

Hence displacement current was introduced

(Also accept any other (correct) explanation.)

2

16.	Calculation of each capacitance	1/2
	Calculation of net capacitance in parallel	1/2
	Energy ratio	1

$$\frac{1}{C_s} = \frac{3}{C}$$

$$C_s = C/3$$

$$1 = C/3$$

$$\therefore C = 3\mu\text{F}$$

$$C_p = C_1 + C_2 + C_3 = 9\mu\text{F}$$

$$\frac{E_s}{E_p} = \frac{\frac{1}{2} C_s V^2}{\frac{1}{2} C_p V^2}$$

$$= 1/9$$

17.	Binding Energy Curve	1
	Explanation	1/2+1/2

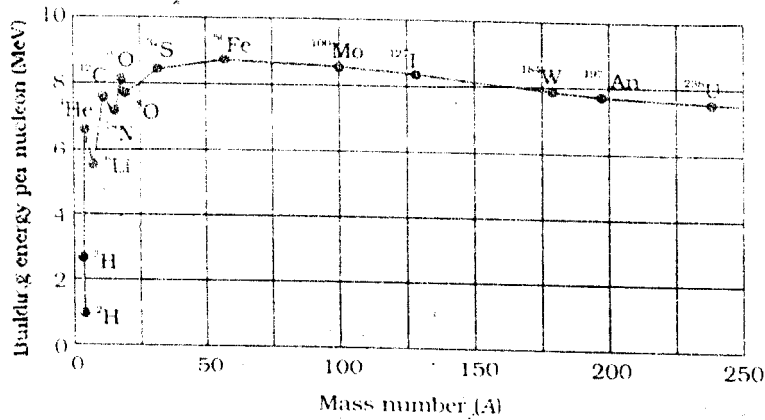

1

The above curve shows that

- (i) When a heavy nucleus breaks into two medium sized nuclei (in nuclear fission) the BE / nucleon increases resulting in the release of energy.
- (ii) When two small nuclei combine to form a relatively bigger nucleus in nuclear fusion BE / nucleon increases, resulting in the release of energy.

1/2

1/2

2

18.	i	New position of balance point	1
	ii.	New position of balance Doint	1

i) $\frac{R}{X} = \frac{l}{100-l}$ When R and X are doubled and interchanged, new balance point is

1/2

$$l' = (100 - l)$$

1/2

[Note: even if the student does not mention the formula, award this 1 mark]

ii) No change in the position of balance point

1

2

19.	Formula	1
	a) Identification	1/2+1/2
	b) Change in focal length	1/2+1/2

$$\frac{1}{f} = (\mu - 1) \left(\frac{1}{R_1} - \frac{1}{R_2} \right)$$

1

a) i) diverging lens or concave lens

1/2

- ii) converging lens or convex lens 1/2
- b) i) focal length will become negative and its magnitude would increase 1/2
- ii) focal length increases 1/2

(Note: Award the 1/2 mark, for case (b) (i), even if the student just writes that the focal length will become negative.)

3

20.	Graph	1 1/2
	Identifying higher stopping potential	1/2
	Justification	1

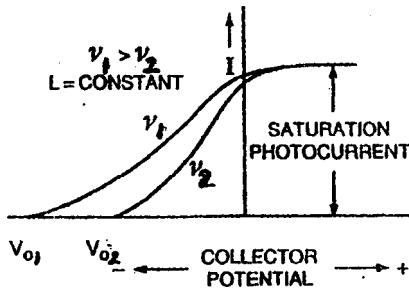

1 1/2

Stopping potential is more for the curve corresponding to frequency v_1

1/2

Stopping potential is directly proportional to the frequency of incident radiation.

1

Alternatively

The maximum energy (of the emitted photoelectrons) increases with an increase in the frequency of the incident radiation.

3

21.	Need for modulation (any two factors)	1+1
	Diagram	1

Need for modulation:

- i) Size of antenna would be very large in the absence of modulation.
- i) Effective power radiated by the antenna would be small in the absence of modulation.

- 1 Mixing up of the signals from different transmitters.
(Any Two)

1+1

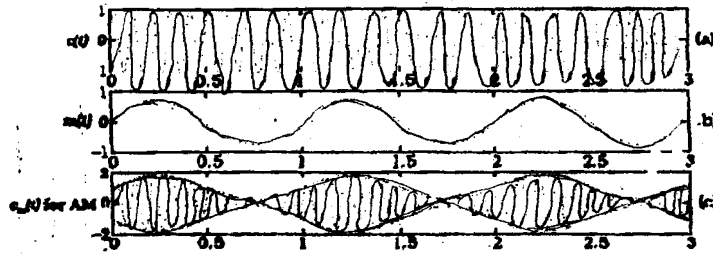

1

(Award this 1 mark for diagram even if only the third part of the diagram is drawn)

3

22.	Mirror formula	1
	Sign convention for focal length	1/2
	a) proof of real and beyond 2f	1/2
	b) proof of virtual image	1/2
	c) proof of virtual and enlarged image	1/2

$$\frac{1}{v} + \frac{1}{u} = \frac{1}{f}$$

1

for concave mirror, $f < 0$ or $f = -ve$

for convex mirror, $f > 0$ or $f = +ve$

1/2

Concave Mirror

Let $f = -c$

Also, Let $u = nf = -nc$

$$\frac{1}{v} = \frac{1}{f} - \frac{1}{u} = -\frac{1}{c} + \frac{1}{nc} = \frac{-n+1}{nc}$$

$$\therefore v = \frac{nc}{(1-n)}$$

- a) When object is between f and $2f$, we have $1 < n < 2$

$\therefore v$ is -ve real image

(For $n=1$ and $n=2$), magnitude of v becomes ∞ and $2c$, respectively

\therefore Real image is formed beyond $2F$.

1/2

c) Object between pole and F we have $0 < u < f$

v is +ve \Rightarrow (virtual image) and $|v| > u$

\therefore We get a virtual, enlarged image

$\frac{1}{2}$

b) Convex Mirror

$f = +d$ Let $u = -pd$ (p can have any value)

$\frac{1}{v} = \frac{1}{d} + \frac{1}{pd} = \frac{(1+p)}{pd}$

$$v = \frac{pd}{(p+1)}$$

$\therefore v$ is always +ve and always less than d

\therefore Convex mirror always produces a virtual image between pole and focus.

$\frac{1}{2}$

3

23.	Circuit diagram	1
	Working principle	1
	Input waveform	$\frac{1}{2}$
	Output waveform	$\frac{1}{2}$

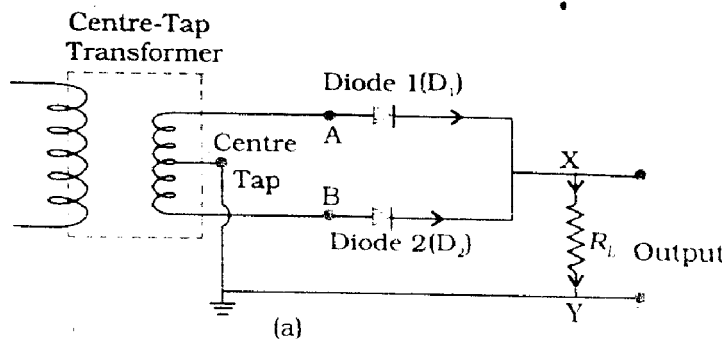

1

Principle

pn junction conducts when it is in forward biased and does not do so when it is reverse biased.

1

[Note: Also accept if the student writes: The two diodes, D_1 and D_2 , let current flow, through the load, for alternate half cycles of the input a.c.]

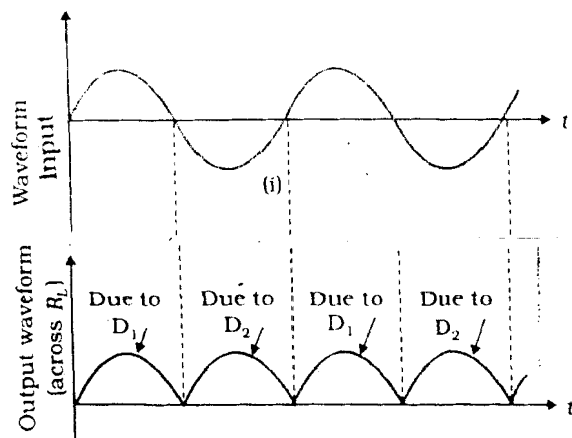

1/2

1/2

3

24.	de-Broglie's formula	1/2
	Diagram	1/2
	Explanation	1
	Kinetic Energy	1/2
	Potential Energy	1/2

(a)
$$\lambda = \frac{h}{p} = \frac{h}{mv}$$

1/2

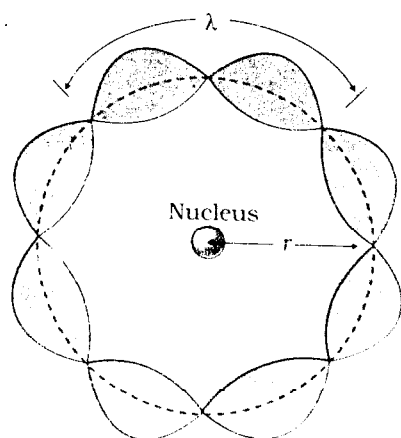

1/2

$$2\pi r = n\lambda$$

$$= n \frac{h}{mv}$$

1/2

$$\Rightarrow mvr = L = \frac{nh}{2\pi}$$

1/2

(b) Kinetic energy = 13.6 eV

1/2

Potential energy = -27.2 eV

1/2

3

26.	Truth Table	2
	Logic Operation	½
	Logic Symbol	½

A	B	$X = \bar{A}$	$Y = \bar{B}$	Z
0	0	1	1	0
0	1	1	0	0
1	0	0	1	0
1	1	0	0	1

2

(If only X and Y are correctly identified properly then award 1 mark only)

[Note: Award the 2 marks for the truth table even if the student does not explicitly writes out the values of X and Y.]

Logic operation is AND or (A.B)

½

Logic Symbol

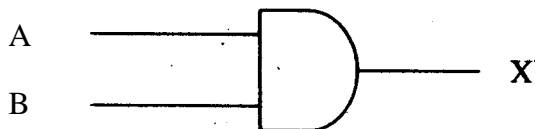

½

3

26.	Lens formula	½
	Magnification formula for objective	½
	Magnification formula for eyepiece	½
	Calculation of magnifying power	1
	Length of the microscope	½

$$\frac{1}{v_0} - \frac{1}{u_0} = \frac{1}{f_0}$$

½

$$f_0 = 4\text{cm}; u_e = -6\text{cm}$$

$$\frac{1}{v_0} = \frac{1}{4} - \frac{1}{6} = \frac{1}{12} \quad \therefore v_0 = 12\text{ cm}$$

magnification by objective, $m_o = \frac{v_o}{|u_o|}$

$$= \frac{12}{6} = 2$$

1/2

Magnification by eyepiece

1/2

$$m_e = \left(1 + \frac{D}{f_e}\right) \quad \text{or} \quad \frac{D}{f_e}$$

$$= \left(1 + \frac{25}{10}\right) \quad \text{or} \quad \frac{25}{10}$$

1/2

$$= 3.5 \quad \text{or} \quad 2.5$$

magnification power of the microscope

$$m = m_o \times m_e$$

$$= 2 \times 3.5 \quad \text{or} \quad 2 \times 2.5$$

1

$$= 7 \quad \text{or} \quad 5$$

Length of the microscope,

$$L = |V_o| + |u_o| \quad \text{or} \quad L = |V_o| + f_e$$

$$u_e = ? \quad v_e = D = -25 \text{ cm}, f_e = 10 \text{ cm}$$

$$\frac{1}{u_e} = \frac{1}{v_e} - \frac{1}{f_e} = -\frac{1}{25} - \frac{1}{10} = -\frac{7}{50}$$

$$u_e = -\frac{50}{7} \text{ cm}$$

$$\therefore L = 12 \text{ cm} + \frac{50}{7} \text{ cm}$$

$$= 19.1 \text{ cm}$$

1/2

Alternativley,

$$L = |V_o| + |f_o|$$

$$= 12 + 10 = 22 \text{ cm}$$

3

OR

Angular magnification	1½
Diameter of the image	1½

Angular magnification, $m = \frac{f_o}{f_e}$ ½

$$= \frac{1500 \text{ cm}}{1 \text{ cm}}$$

$$= 1500 \quad \quad \quad 1$$

$\frac{\text{Diameter of image of moon } (d)}{\text{Focal length of objective } (f_o)} = \frac{\text{Diameter of the moon}}{\text{Radius of Lunar orbit}}$ ½

$$d = 1500 \times \frac{3.42 \times 10^6}{3.80 \times 10^6} \quad \quad \quad \frac{1}{2}$$

$$= 13.5 \text{ cm} \quad \quad \quad \frac{1}{2} \quad \quad \quad 3$$

27. Expressions for P_1 and P_2	½+½
Expression for power in series	1
Expression for power in parallel	1

$$P_1 = \frac{V^2}{R_1} \quad \quad \quad \frac{1}{2}$$

$$P_2 = \frac{V^2}{R_2} \quad \quad \quad \frac{1}{2}$$

In Series

$$P = \frac{V^2}{R_1 + R_2} \quad \quad \quad 1$$

Alternatively

$$P = \frac{V^2}{V^2 \left(\frac{1}{P_1} + \frac{1}{P_2} \right)}$$

$$\frac{1}{P} = \frac{1}{P_1} + \frac{1}{P_2}$$

In Parallel

$$P = \frac{V^2(R_1 + R_2)}{R_1 R_2}$$

Alternatively

$$P = \frac{V^2}{R} = \frac{V^2(P_1 + P_2)}{V^2}$$

$$P = P_1 + P_2$$

1

3

28.	Principle of working	1
	Labelled diagram	1
	Justification	1
	Conversion into an ammeter	2

Principle

- a) A current carrying coil when kept inside a uniform magnetic field, experience a torque

1

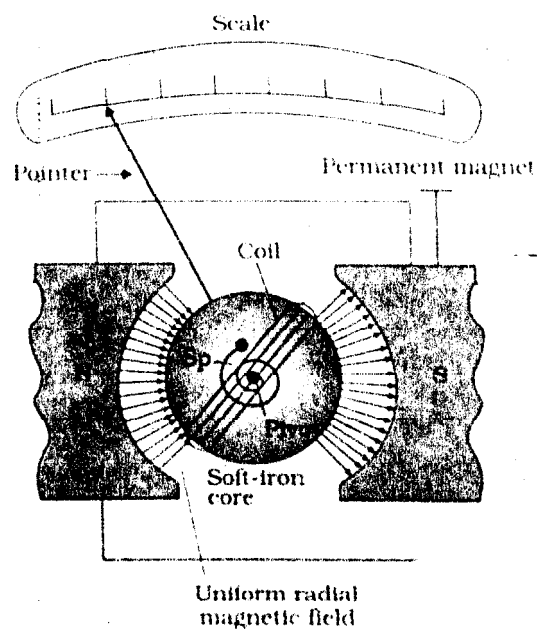

1

$$b) I_s = \frac{NAB}{k}, V_s = \frac{NAB}{kR}$$

1

Alternatively,

Unlike current sensitivity, the voltage sensitivity depends upon number of turns as well on to the resistance of the coil.

Alternatively,

By increasing number of turns, resistance of the coil also increases proportionally. Hence, the two sensitivities need not show identical variations

c)

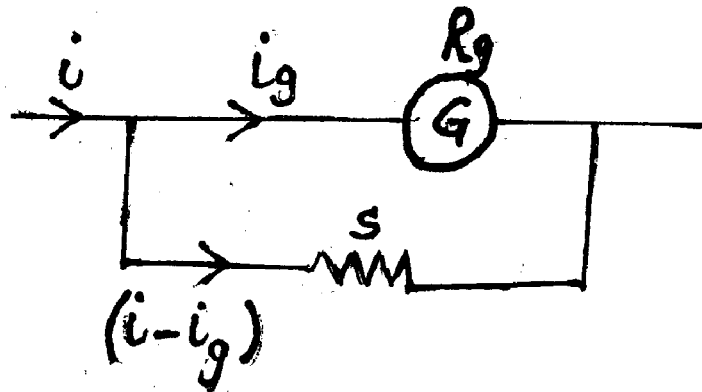

To convert galvanometer into ammeter of range 0 to i , we have to connect a low resistance shunt in parallel.

$$S = \frac{i_g}{(i - i_g)} R_g$$

1

5

OR

Expression for magnetic field	2
Difference between solenoid and toroid	1
Comparison of magnetic field lines	1
Strengthening of magnetic field	1

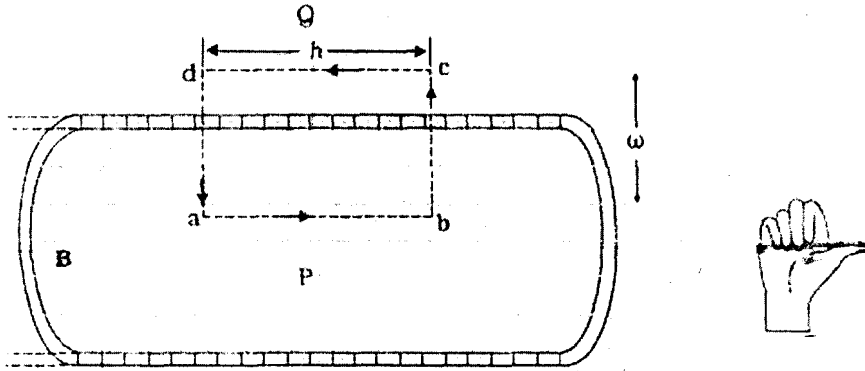

1

$$\oint \vec{B} \cdot d\vec{l} = \mu_0 \sum i$$

$$\int_a^b \vec{B} \cdot d\vec{l} + \int_b^c \vec{B} \cdot d\vec{l} + \int_c^d \vec{B} \cdot d\vec{l} + \int_d^a \vec{B} \cdot d\vec{l} = \mu_0 I(nh)$$

1/2

$$Bh + 0 + 0 + 0 = \mu_0 I(nh)$$

$$B = \mu_0 nI$$

1/2

b) (Any one difference ~ In a toroid, magnetic lines do not exist outside the body.

1

→ Toroid is closed whereas the solenoid is open on both sides

→ Magnetic field is uniform inside a toroid whereas for 'solenoid, it is different at the two ends and centre.

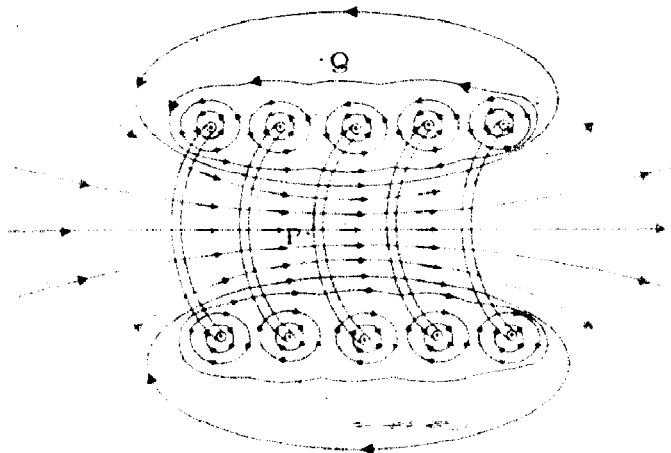

1/2

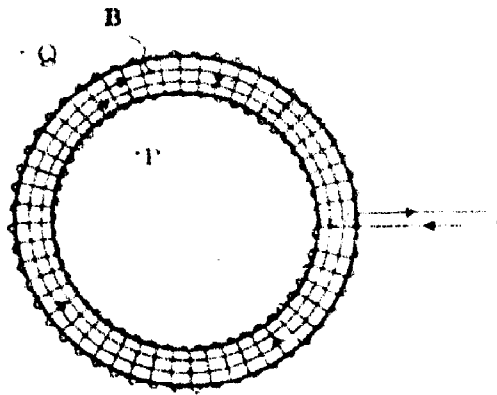

1/2

Strengthening of magnetic field: (Any one)

- 1 By inserting a ferromagnetic substance inside the solenoid
- 1 By increasing the amount of current through the solenoid

1

5

29.

Working	1
Labelled diagram	1
Expression for alternating emf generated	2
Source of energy generation	1

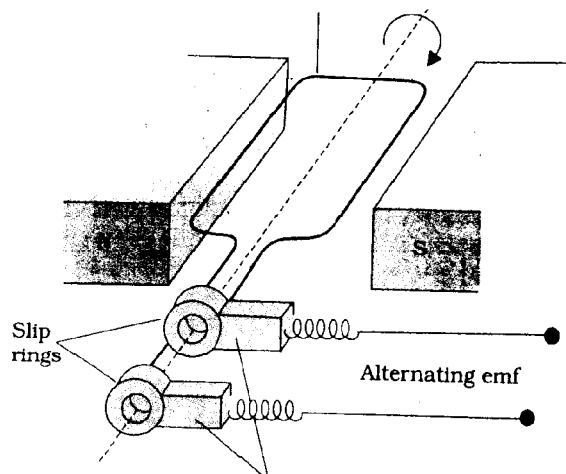

1

Working : When a coil (armature) rotates inside a uniform magnetic field, magnetic flux linked with the coil changes w.r.t. time. This produces an e.m.f according to Faraday's Law.

1/2

For first half of the rotation the current will be from one end (first ring) to the other end (second ring). For second half of the rotation it is in opposite sense.

1/2

At any instant $\phi = \vec{NB} \cdot \vec{A}$

$$= NBA \cos\theta$$

$$= NBA \cos \omega t \quad 1$$

From Faraday's Law

$$\varepsilon = - \frac{d\phi_B}{dt} = - NBA \frac{d(\cos \omega t)}{dt} \quad \frac{1}{2}$$

$$= NBA \omega \sin \omega t \quad \frac{1}{2}$$

$$= \varepsilon_0 \sin \omega t \quad 1$$

Source of energy :- Mechanical energy

(Award ½ mark only if the answer is any of the 'fuels' used for providing mechanical energy)

5

OR

(a) Phase difference	3
(b) Instantaneous e.m.f.	1
Direction	½
Identification	½

(a) $\varepsilon = \varepsilon_0 \sin \omega t \quad \frac{1}{2}$

$$\varepsilon - L \frac{di}{dt} = 0$$

$$\frac{di}{dt} = \frac{\varepsilon}{L} = \frac{\varepsilon_0}{L} \sin \omega t \quad \frac{1}{2}$$

$$\int_0^i \frac{di}{dt} dt = \frac{\varepsilon_0}{L} \int_0^t \sin \omega t dt$$

$$i = - \frac{\varepsilon_0}{\omega L} \cos \omega t \quad \frac{1}{2}$$

$$\frac{\varepsilon_0}{X_L} \sin(\omega t - \pi/2), X_L = \omega L \quad 1$$

$$i = i_0 \sin\left(\omega t - \frac{\pi}{2}\right)$$

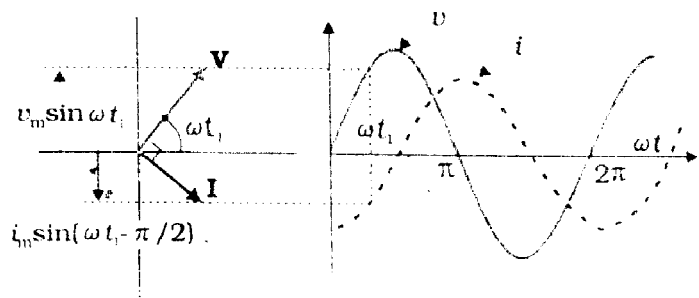

1/2

(b) i) $e = BLv$

1

ii) West to east

1/2

iii) East

1/2

5

30.

Importance of coherent sources	1
Conditions for constructive and destructive interference	1 1/2
Expression for fringe width	2
Effect of immersing in water	1/2

If coherent sources are not taken, the phase difference, between the two interfering waves, will change continuously and a sustained interference pattern will not be obtained.

1

$$y_1 = a \cos wt$$

$$y_2 = a[\cos(wt + f)]$$

$$y = y_1 + y_2$$

$$y = a[\cos wt + \cos(wt + f)]$$

1/2

$$y = 2a \cos\left(\frac{\phi}{2}\right) \cos(wt + f/2)$$

Resultant amplitude = $2a \cos(\phi/2)$

$$I = 4I_0 \cos^2(\phi/2)$$

Condition for constructive interference

$$\phi = 0, \pm 2\pi, \pm 4\pi, \dots \text{ or } \phi = \pm 2n\pi \text{ (n = 0, 1, 2, \dots)}$$

1/2

Condition for destructive interference

$$\phi = \pm \pi, \pm 3\pi, \pm 5\pi, \dots \text{ or } \phi = \pm (2n + 1)\pi \text{ (n = 0, 1, 2, \dots)}$$

1/2

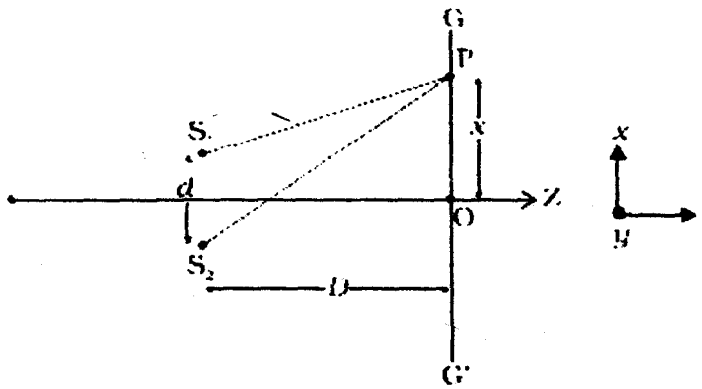

1/2

We have

$$(S_2P)^2 - (S_1P)^2 = \left[D^2 + \left(x + \frac{d}{2} \right)^2 \right] - \left[D^2 + \left(x - \frac{d}{2} \right)^2 \right] = 2xd$$

1/2

$$\therefore S_2P - S_1P = \frac{2xd}{S_2P + S_1P} \approx \frac{2xd}{2D} = \frac{xd}{D}$$

For maxima,

$$S_2P - S_1P = n\lambda$$

Hence position of maxima is given by

1/2

$$x_n = \frac{n\lambda D}{d} \text{ where } n = 0, \pm 1, \pm 2, \dots$$

1/2

Hence fringe width

$$\beta = x_{n+1} - x_n$$

$$\beta = \frac{\lambda D}{d}$$

1/2

\therefore Fringe width will decrease in water as $\lambda_w < \lambda_a$

1/2

5

OR

a)	Statement of Huygen's principle	1
	explanation of diffraction pattern	1½
b)	Angular width of the first diffraction fringe	1
	Width of central fringe	½
	Relation between the two	½
c)	Effect of using white light	½

- (i) Each point of the wavefront is the source of a secondary disturbance and the wavelets emanating from these points spread out in all directions with the speed of the wave. ½
- (ii) These wavelets emanating from the wavefront are usually referred to as secondary wavelets and if we draw a common tangent to all these spheres, we obtain the new position of the wavefront at a later time. ½

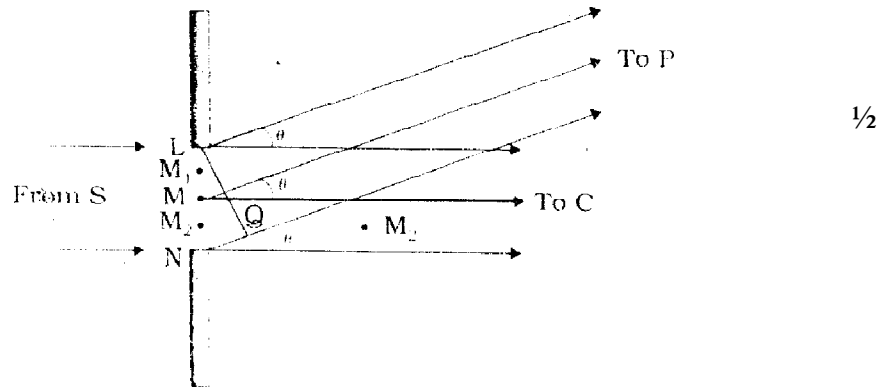

Divide the slit into (smaller) parts, and add their contributions at P with the proper phase differences. We are treating different wavefront at the slit as secondary sources,

These sources are in phase.

The path difference $NP-LP := NQ$

$$= a \sin \theta$$

$$\cong a \theta$$

½

Similarly $M_2P - M_1P = y \phi$

Destructive superposition of secondary wavelets can take place and hence a diffraction pattern is obtained on the screen

n th secondary minima

$$\theta_n = \frac{n\lambda}{a}$$

Width of first diffraction fringe $\theta_2 - \theta_1 = \frac{2\lambda}{a} - \frac{\lambda}{a} = \frac{\lambda}{a}$ 1

The width of central maxima is the distance between the first secondary minimum on either side of the central point O

$$\theta_1 = \frac{\lambda}{a}$$

$$\theta_{-1} = \frac{\lambda}{a}$$

Width of the central fringe $= [\theta_1 - \theta_{-1}] = \frac{\lambda}{a} - \left(-\frac{\lambda}{a}\right)$
 $= \frac{2\lambda}{a}$ 1

Hence the fringe width of the first diffraction fringe is half that of the central fringe. 1/2

(c) When source is emitting white light, the diffraction pattern is coloured. 1/2

Alternatively,

The central maximum is white, but other bands are coloured. 5